



# Qzone Phonebooth

Falling in love with quiet

# Qzone Phonebooth

## Product Data Specification

Add a bit of private space to your open plan office. Qzone is perfect for sensitive phone calls, working on confidential documents, or just a bit of peace and quiet. Available in white or new oak with a large range of colour/ print customizations available on the side panels.

### Standard Features

In stock in Grey/ White and Grey/ New Oak

Toughened glass door

Flat packed for easy moving and transportation, fits comfortably in most lifts

Motion sensor, light, extraction fan, GPO & USB power outlet

Made with acoustic panel that helps tune out noise

10 years warranty (excludes electrical components)

Comes with bench to take notes or work on your laptop

Internal walls absorb 75% of sound waves (100 fold reduction in sound intensity)

### Optional Extras

Wireless fast charge in worktop

Change outer e-panel colours: 4 weeks lead time

Printing on white outer panel (includes artwork design & approval): 4 weeks lead time

Glass door and/ or rear panel frosting (includes artwork design, work completed by sign maker after assembly)

Window panel to back wall- special order: 14-16 weeks

Box shelf upgrade (second shelf level and bag hook)- special order: 14-16 weeks

### Colour Options:

AcoustiQ Panel Sides:



Melamine Front & Back:

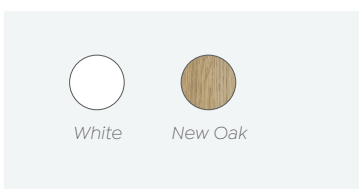

# Qzone Phonebooth

## Product Data Specification

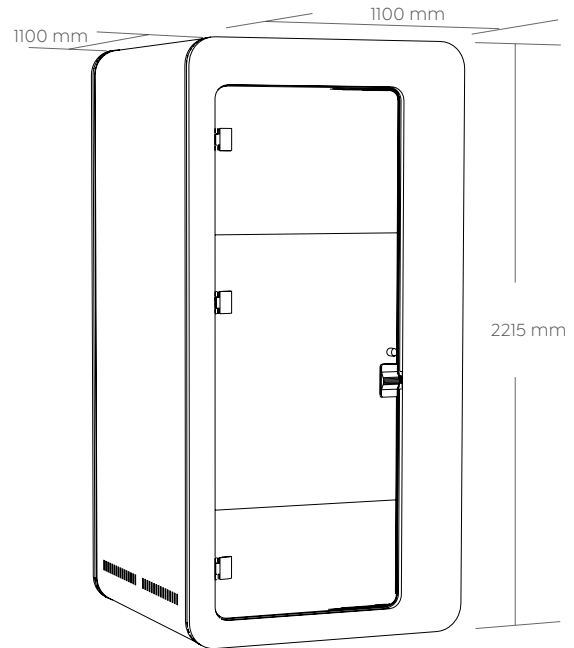
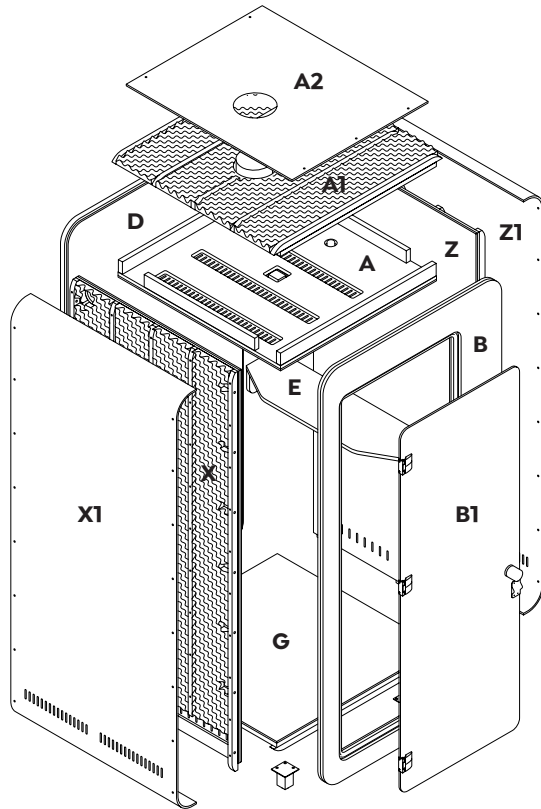

### Specifications:

<b>A</b> Ceiling Panel	<b>E</b> Shelf
<b>A1</b> Top Panel	<b>G</b> Bottom Panel
<b>A2</b> AcoustiQ Panel	<b>X</b> Side Panel
<b>B</b> Front Panel	<b>X1</b> AcoustiQ Side Panel
<b>B1</b> Glass Door	<b>Z</b> Side Panel
<b>D</b> Back Panel	<b>Z1</b> AcoustiQ Side Panel

### Specifications:

Weight: 275 kg.  
Size: 1100 (w) x 1100 (d) x 2215 (h) mm.



New Oak / Grey



White / Grey

# Qzone Phonebooth

## Noise Reduction Specifications

Qzone has been assessed in a SGS facility to test noise reduction effectiveness of the booth with the door closed (test conducted: GB/T 18699. 1-2002).

This assessment found that the booth's weighted sound pressure isolation level is 21 - that's the equivalent of an alarm clock being reduced to a normal conversation, or a quiet office to a library.

## Shipment Box Specifications

### Packing Type:

10 cartons (including Softwiring)

Max weight: 60kg

Min weight: 1kg

Assembly time: 2 people, 2 hours,  
simple electrical work required.

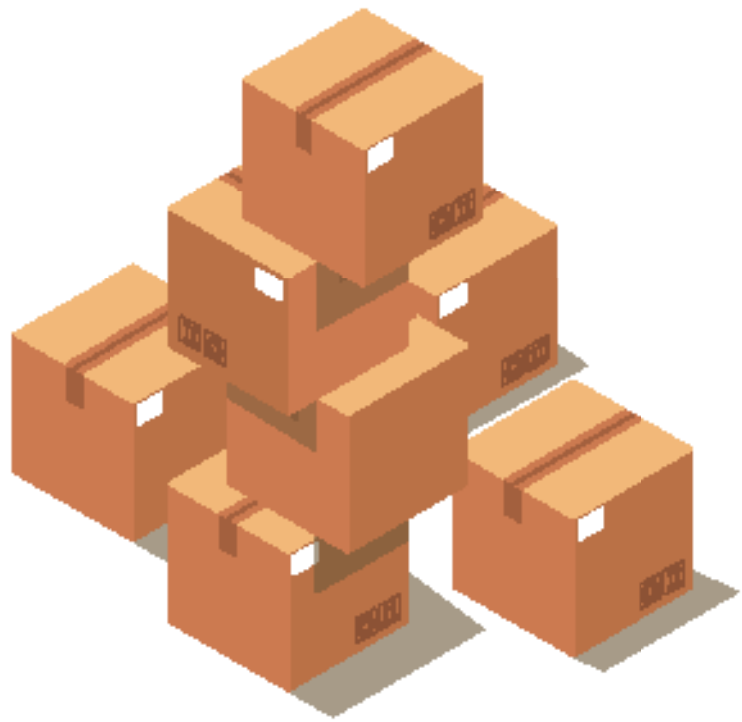

### Carton Dimensions and Weights:

1 x 1100mm (w) x 1065mm (d) x 70mm (h) - 33kg

1 x 1065mm (w) x 1025mm (d) x 115mm (h) - 27kg

1 x 1100mm (w) x 1065mm (d) x 85mm (h) - 28kg

1 x 1065mm (w) x 1065mm (d) x 170mm (h) - 19kg

1 x 2190mm (w) x 1065mm (d) x 75mm (h) - 38kg

### Carton Dimensions and Weights:

1 x 2190mm (w) x 1065mm (d) x 75mm (h) - 38kg

1 x 2280mm (w) x 1065mm (d) x 70mm (h) - 60kg

1 x 2280mm (w) x 1065mm (d) x 70mm (h) - 43kg

1 x 2000mm (w) x 1065mm (d) x 50mm (h) - 21kg

1 x 210mm (w) x 310mm (d) x 90mm (h) - 1kg