

Power Input / Regulator

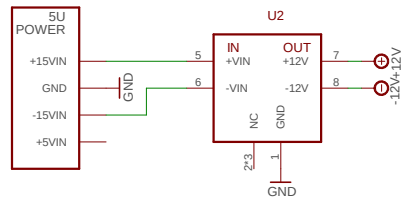

PCB Connecting Headers

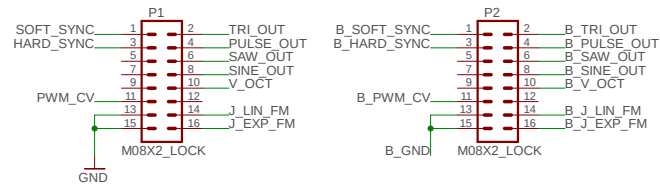

Pots

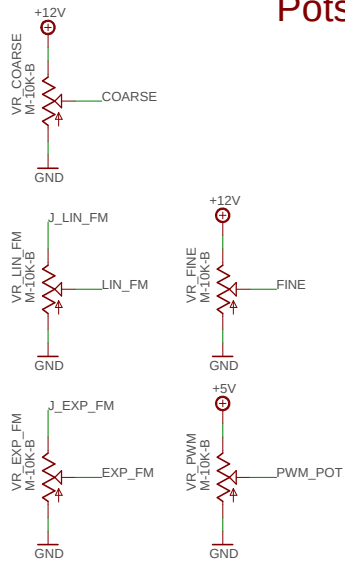

Submodule

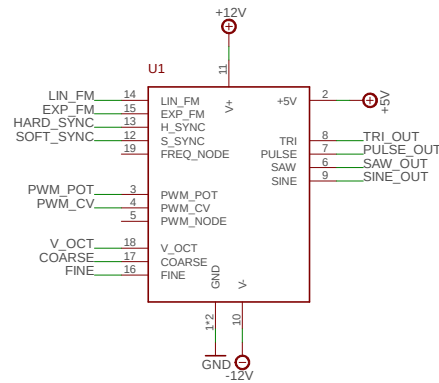

Jacks

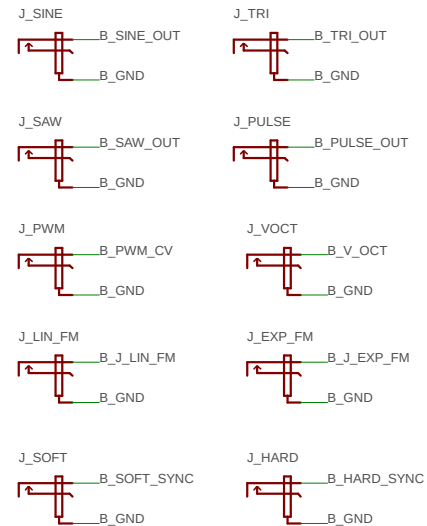

ELECTROSMITH_CIRCLE_21MM

Electrosmith

LOGO1

LOGO2

Electrosmith

ELECTROSMITH_TEXT_3X30MM

ES_3340_VCO_MU_Rev2

8/9/2019 11:21 AM

Sheet: 1/1