

---

# NGI Bearing Unit



*CERAMICSPEED*

# Certified Hygienic Bearing Houses

The only patented bearing house in the world, hygienically designed and certified by EHEDG, 3-A, and USDA standards, with extremely easy access for cleaning from all angles.

- Designed in accordance with EHEDG and 3-A design principles to meet and exceed the demands of modern production lines.
- Equipped with CeramicSpeed Hybrid Bearings which are fitted with premium-quality ceramic (Si<sub>3</sub>N<sub>4</sub>) balls. These ceramic balls are twice as hard as steel, 4 times smoother, and require much less lubrication.
- The bearing house provides a patented waterproof sealing that allows for 3 degrees of misalignment and can be equipped with a high-performance ceramic bearing lubricated for life, offering 4-8 times extended lifetime.
- Produced in high-quality glass fiber-reinforced Grilamid.
- Designed with a smooth and round surface, making it impossible for bacteria and water to penetrate.

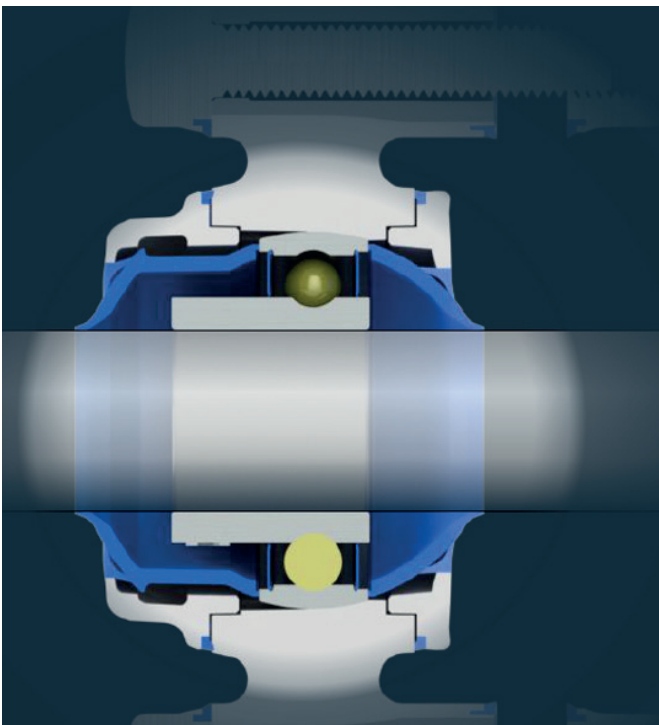



# Hygienic Bearings With C

Our bearings are pre-installed in the bearing houses and we currently offer 4 types - stainless steel or ceramic hybrid bearing with screws or locking collar.

NGIs certified hygienic bearing houses with IP69K sealing provide the ideal environment for the bearing and are therefore suitable for maintenance-free operation.

The main operating parameters that determine the lifetime of the bearing are bearing type and size, load, speed, operating temperature, shaft tolerances.

Our ball bearings are greased-for-life with high-performance multi-purpose grease designed specifically for the lubrication of food processing machinery all sealed-for-life by seals made from FDA-approved blue NBR.

The locking method with screws is the most common locking function.

Bearings with an eccentric locking collar are intended primarily for use in applications where the direction of rotation is constant. On one side of the bearing inner ring is an eccentric extension that fits the locking collar.

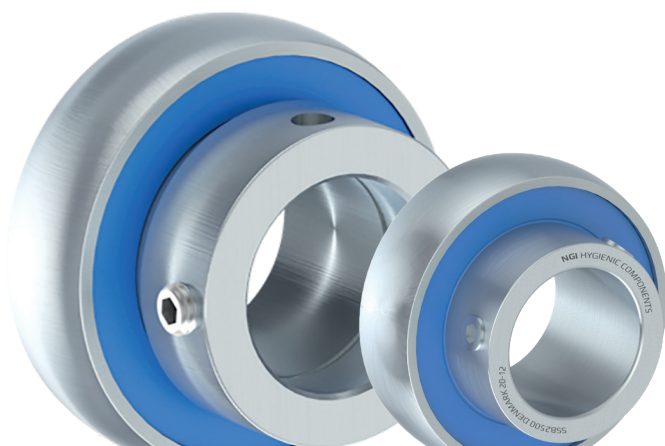
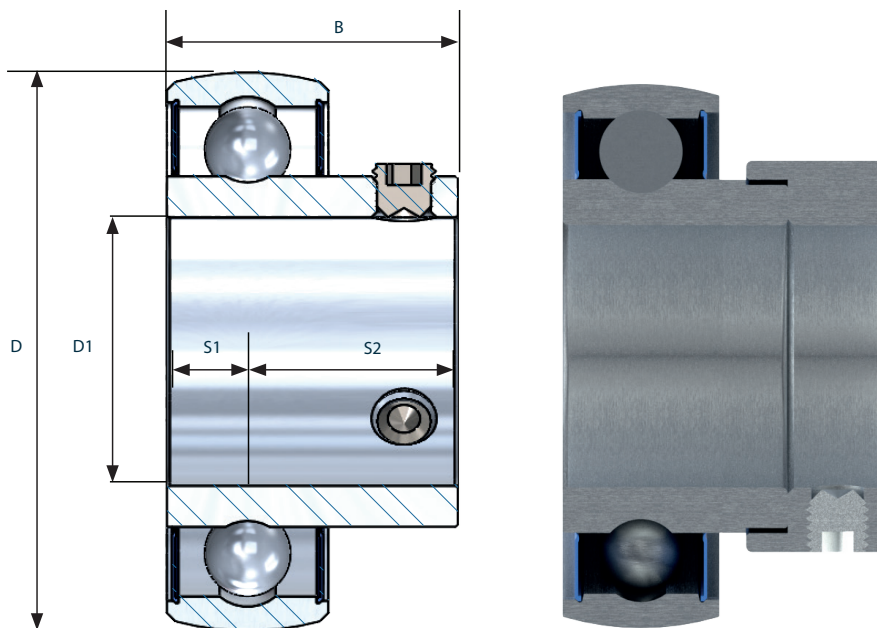

# Ceramic Balls

Locking function	Size D [mm]	Shaft Diameter D1 [mm]	Width B [mm]	Distance S1 [mm]	Max Speed bearing [R/MIN]*	Static Load Rating Co [N]	Dynamic load rating C [N]	Item Code
With Screws	47	20	25	18	4800	4032	10370	CSB1905
With Screws	52	25	27	19.5	4200	4776	11310	CSB2540
With Screws	62	30	30	22	3780	6912	15730	CSB3175
With Screws	72	35	34	24,5	3150	9344	20830	CSB3493
With Screws	80	40	37	26,5	2750	10880	23550	CSB3810
With Locking Collar	47	20	25	18	4800	4032	10370	CSA1905
With Locking Collar	52	25	27	19.5	4200	4776	11310	CSA2540
With Locking Collar	62	30	30	22	3780	6912	15730	CSA3175
With Locking Collar	72	35	34	24,5	3150	9344	20830	CSA3493
With Locking Collar	80	40	37	26,5	2750	10880	23550	CSA3810

\* The hygienic bearing house is typically used on conveyors rotating at relatively low speeds (below 2000 rpm), the housing creates a hygienic environment for the bearing, and it would be optimal to mount it on an AISI hard surface between 0.8  $\mu\text{m}$  and 1.6  $\mu\text{m}$  Ra with a tolerance not exceeding h9, preferably lower.

## Superior to Steel

The CeramicSpeed Balls are 15% harder, take 99% higher loads, and are more than 100% smoother than other ceramic balls typically seen in the market. Ceramic balls can be found in a variety of materials. The best material available - and the one used for our bearings - is silicon nitride (Si<sub>3</sub>N<sub>4</sub>).

Ceramic balls are superior to steel balls in all physical measurable properties. This ensures many benefits in the bearing: The increased hardness of the ball means that the contact area between the ball and the track is reduced leading to lower friction, higher potential speeds, and less energy waste. The hardness and the extremely smooth surface also mean that the balls are far more durable than steel balls. Ceramic balls are also significantly lighter than steel balls which reduces the centrifugal load on the raceway as the bearing spins, and wear and tear are significantly reduced, keeping the bearing in top condition for longer. As an added benefit the bearing can operate at much higher RPMs - up to 50 % higher - giving the possibility of using long-life bearings in demanding high-speed applications, such as machine tool spindles and turbomachinery.

One of the main advantages of ceramic balls over steel ones is their low friction coefficient - this reduces the need for lubrication quite significantly.

# XB2FC

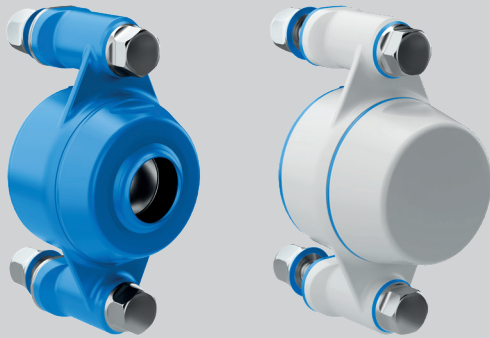

## Special features

- 2 hole flange bearing house
- Mounted parallel to shaft direction
- Shaft diameter 20 mm - 40 mm
- Can be supplied with certified hygienic nuts and bolts for maximum hygienic safety

# XB4FC

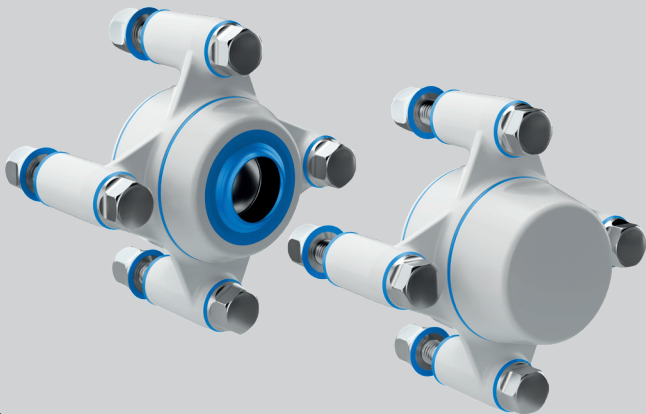

## Special features

- 4 hole flange bearing house
- Mounted parallel to shaft direction
- Shaft diameter 20 mm - 40 mm
- Can be supplied with certified hygienic nuts and bolts for maximum hygienic safety

# XB3FC

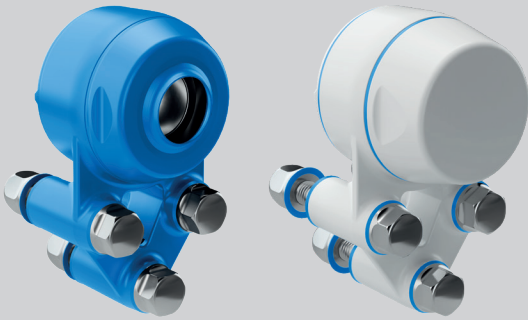

## Special features

- 3 hole flange bearing house
- Mounted parallel to shaft direction
- Shaft diameter 20 mm - 40 mm.
- Can be supplied with certified hygienic nuts and bolts for maximum hygienic safety

# XBPBC

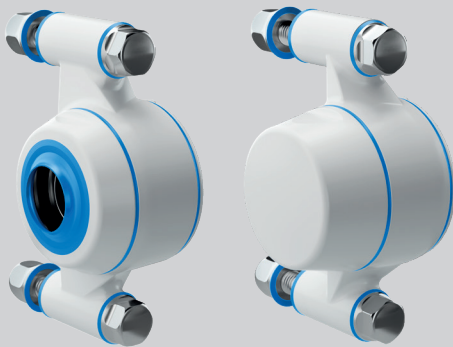

## Special Features

- Pillow block bearing house
- Mounted perpendicularly to shaft direction
- Shaft diameter 20 mm - 35 mm
- Can be supplied with certified hygienic nuts and bolts for maximum hygienic safety.

# XB2FC

## Certified Hygienic Bearing Houses



The design and patent protected XB2FC 2-hole flange bearing house is the optimal choice for machinery and equipment that has to comply with strict hygiene requirements.

The XB2FC bearing house is mounted parallel to shaft direction

The XB2FC is designed to provide easy access for cleaning from all angles. We recommend that you choose a bearing house with NGI's hygienic nuts and bolts for maximum hygienic safety.

The XB2FC meets the requirements of EC 1935/2004, EC 10/2011, EC 2023/2006 and FDA.



-  Certified Hygienic
-  Minimized Cleaning Time
-  Minimized Water Usage

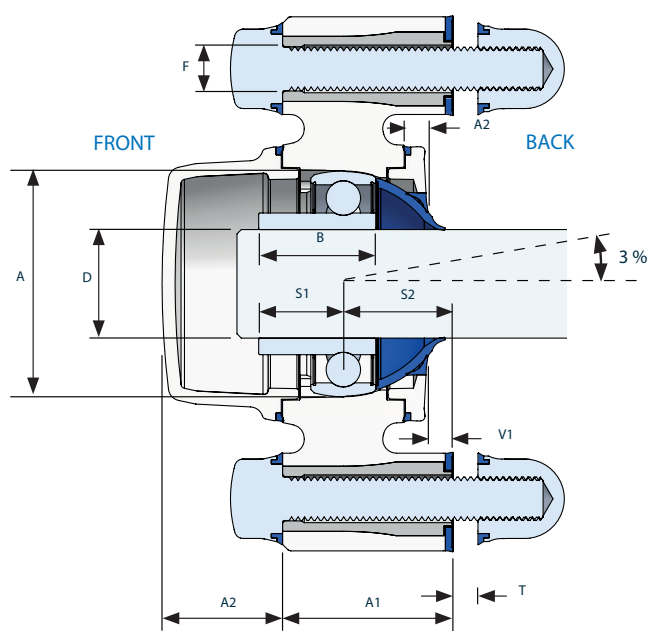
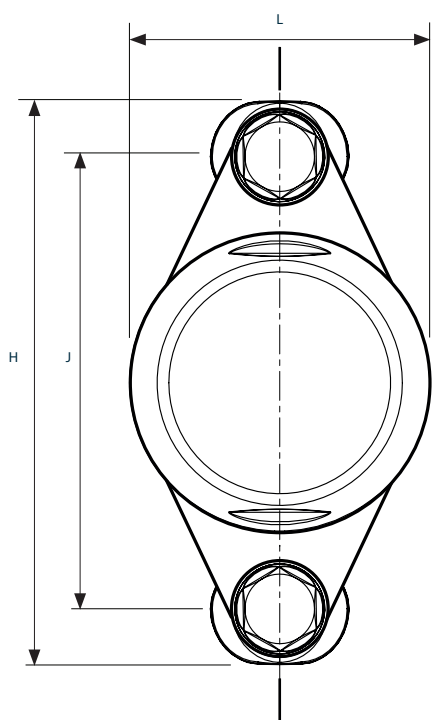





Product code	Bearing house	Bearing type	Front cover	Back cover	Bolt (optional)
Example	XB2FC52-	SSB2500-	CL(W)-	OS(W)-	BXHM1050

### Bearing House



Size A [mm]	Shaft Diameter D [mm]	V1 [mm]	J [mm]	F [mm]	H [mm]	L [mm]	A1 [mm]	S2 [mm]	Item Code
47	20	7,5	90	10,2	114,2	57,8	36	24	XB2FC47
52	25	6,4	99	10,2	123	65,8	39	25	XB2FC52
62	30	6,6	116,5	10,2	144,9	79,7	41,5	27	XB2FC62
72	35	7,1	130	12,2	160,4	91,7	46,5	30	XB2FC72
80	40	7,4	143,5	12,2	175,9	101,6	50	32	XB2FC80

### Bearing Type



Bearing Ball material	Shaft Diameter D [mm]	Width B [mm]	Distance S1 [mm]	Maximum Speed Sealing [R/Min]	Static Load Rating C <sub>0</sub> [N]	Dynamic Load rating C [N]	Item Code
Stainless steel w. screws	20	25	18	1875	5040	10370	SSB1905
Stainless steel w. screws	25	27	19,5	1500	5970	11310	SSB2540
Stainless steel w. screws	30	30	22	1250	8640	15730	SSB3175
Stainless steel w. screws	35	34	24,5	1070	11680	20830	SSB3493
Stainless steel w. screws	40	37	26,5	940	13600	23550	SSB3810

### Cover



Size A [mm]	Shaft Diameter D [mm]	OS [Open Small] A2	OM [Open medium] A2	CM [Closed Medium] A2	CL [Closed Large] A2
47	20	4,5	14,6	16,7	-
52	25	4,6	14,6	17,2	27,5
62	30	5,9	20,4	23,3	35,7
72	35	6,4	19,5	23,2	-
80	40	6,6	22,3	26,2	-

### Nut and Bolt



Color	Color Code
White	(W)
Blue	(B)
Black	(S)

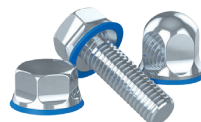

# XB3FC

## Certified Hygienic Bearing Houses

The design and patent protected XB3FC 3-hole flange bearing house is the optimal choice for machinery and equipment that has to comply with strict hygiene requirements.

The XB3FC bearing house is mounted parallel to shaft direction

The XB3FC is designed to provide easy access for cleaning from all angles. We recommend that you choose a bearing house with NGI's hygienic nuts and bolts for maximum hygienic safety.

The XB3FC meets the requirements of EC 1935/2004, EC 10/2011, EC 2023/2006 and FDA.

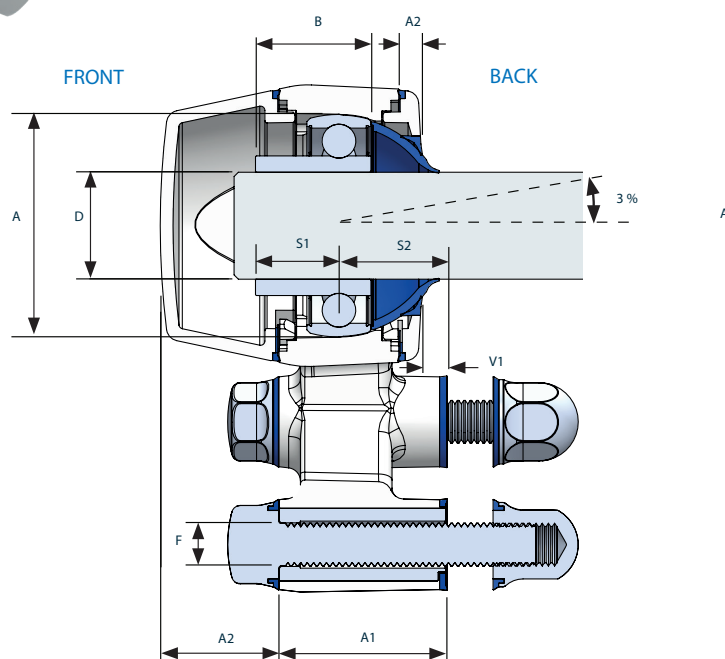
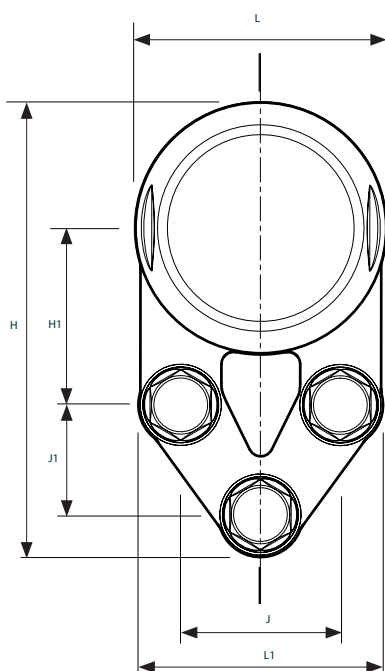
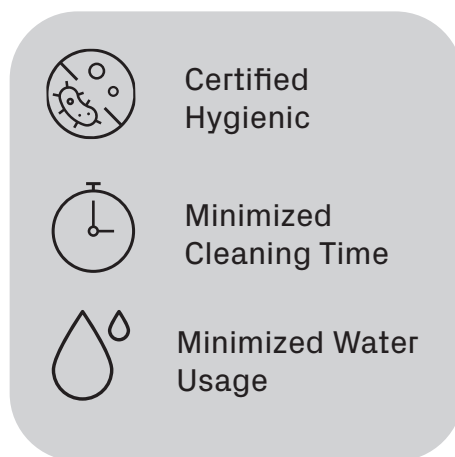



Product code	Bearing house	Bearing type	Front cover	Back cover	Bolt (optional)
Example	XB3FC52-	SSB2500-	CL(W)-	OS(W)-	BXHM1050

### Bearing House



Size A [mm]	Shaft Diameter D [mm]	V1 [mm]	J [mm]	J1 [mm]	F [mm]	H [mm]	H1 [mm]	L [mm]	L1 [mm]	A1 [mm]	S2 [mm]	Item Code
47	20	7,5	38	22	10,2	104,8	43	57,7	60	36	24	XB3FC47
52	25	6,4	41,5	28,5	10,2	118,3	46	65,6	63,5	39	25	XB3FC52
62	30	6,6	47,5	32	10,2	137,3	52,5	79,6	72,3	41,5	27	XB3FC62
72	35	-	-	-	-	-	-	-	-	-	-	XB3FC72
80	40	-	-	-	-	-	-	-	-	-	-	XB3FC80

### Bearing Type



Bearing Ball material	Shaft Diameter D [mm]	Width B [mm]	Distance S1 [mm]	Maximum Speed Sealing [R/Min]	Static Load Rating C <sub>0</sub> [N]	Dynamic Load rating C [N]	Item Code
Stainless steel w. screws	20	25	18	1875	5040	10370	SSB1905
Stainless steel w. screws	25	27	19,5	1500	5970	11310	SSB2540
Stainless steel w. screws	30	30	22	1250	8640	15730	SSB3175
Stainless steel w. screws	-	-	-	-	-	-	-
Stainless steel w. screws	-	-	-	-	-	-	-

### Cover



Size A [mm]	Shaft Diameter D [mm]	OS [Open Small] A2	OM [Open medium] A2	CM [Closed Medium] A2	CL [Closed Large] A2
47	20	4,5	14,6	16,7	-
52	25	4,6	14,6	17,2	27,5
62	30	5,9	20,4	23,3	35,7
72	35	6,4	19,5	23,2	-
80	40	6,6	22,3	26,2	-

### Nut and Bolt



Color	Color Code
White	(W)
Blue	(B)
Black	(S)

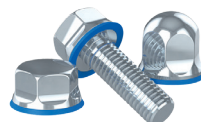

# XB4FC

## Certified Hygienic Bearing Houses

The design and patent protected XB4FC 4-hole flange bearing house is the optimal choice for machinery and equipment that has to comply with strict hygiene requirements. The XB4FC bearing house is mounted parallel to shaft direction

The XB4FC is designed to provide easy access for cleaning from all angles. We recommend that you choose a bearing house with NGI's hygienic nuts and bolts for maximum hygienic safety.

The XB4FC meets the requirements of EC 1935/2004, EC 10/2011, EC 2023/2006 and FDA.

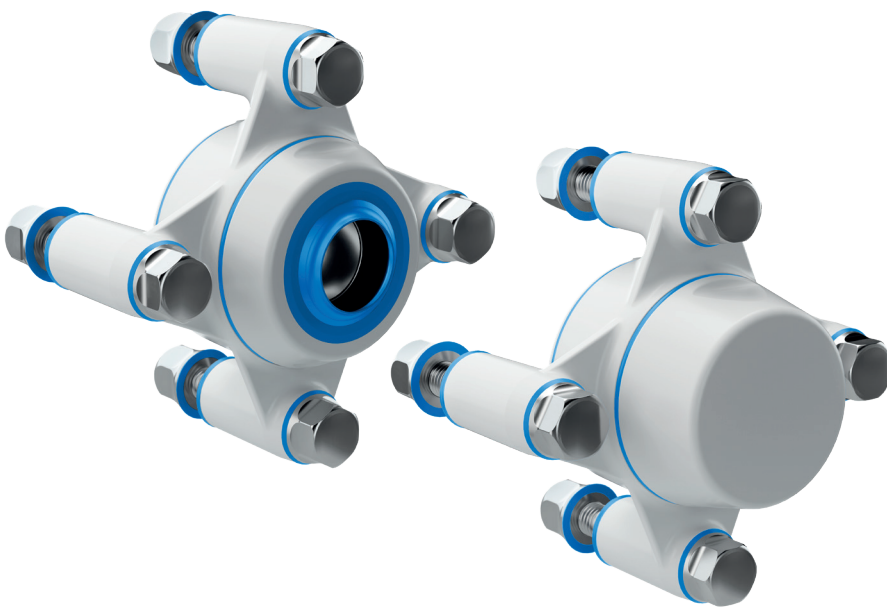

-  Certified Hygienic
-  Minimized Cleaning Time
-  Minimized Water Usage

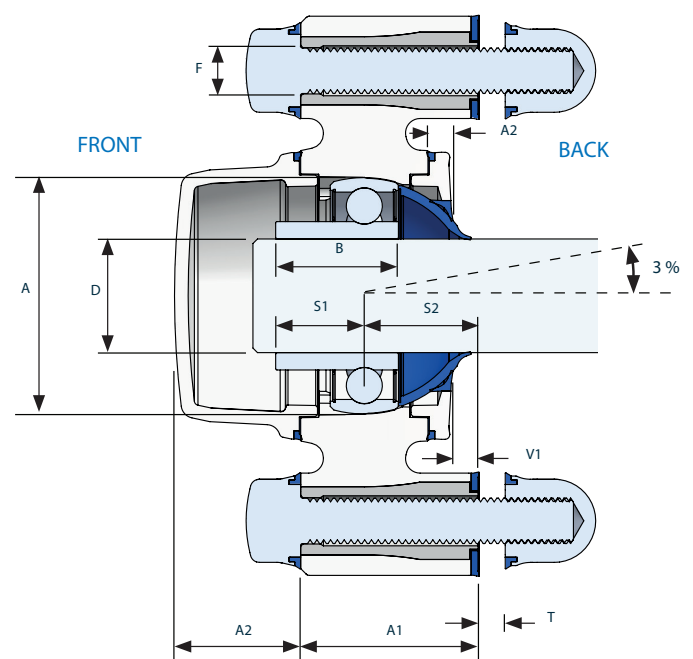
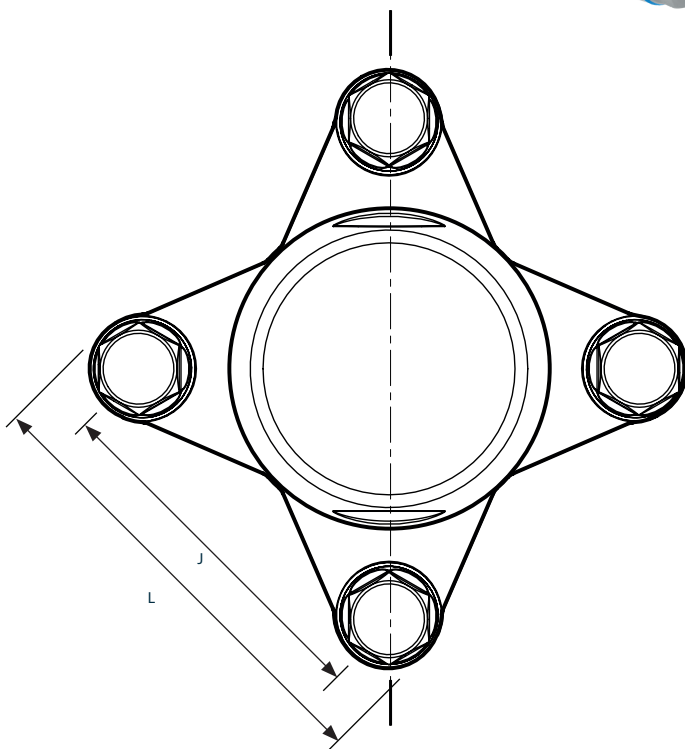



Product code	Bearing house	Bearing type	Front cover	Back cover	Bolt (optional)
EXAMPLE	XB4FC52-	SSB2500-	CL(W)-	OS(W)-	BXHM1050

### Bearing house



Size A [mm]	Shaft Diameter D [mm]	V1 [mm]	J [mm]	F [mm]	L [mm]	A1 [mm]	S2 [mm]	Item Code
47	20	7,5	63,5	10,2	84,7	36	24	XB4FC47
52	25	6,4	70	10,2	92	39	25	XB4FC52
62	30	6,6	82,5	10,2	109,1	41,5	27	XB4FC62
72	35	7,1	92	12,2	119,2	46,5	30	XB4FC72
80	40	7,4	101,5	12,2	130,8	50	32	XB4FC80

### Bearing Type



Bearing Ball material	Shaft Diameter D [mm]	Width B [mm]	Distance S1 [mm]	Maximum Speed Sealing [R/Min]	Static Load Rating C <sub>0</sub> [N]	Dynamic Load rating C [N]	Item Code
Stainless steel w. screws	20	25	18	1875	5040	10370	SSB1905
Stainless steel w. screws	25	27	19,5	1500	5970	11310	SSB2540
Stainless steel w. screws	30	30	22	1250	8640	15730	SSB3175
Stainless steel w. screws	35	34	24,5	1070	11680	20830	SSB3493
Stainless steel w. screws	40	37	26,5	940	13600	23550	SSB3810

### Cover



Size A [mm]	Shaft Diameter D [mm]	OS [Open Small] A2	OM [Open medium] A2	CM [Closed Medium] A2	CL [Closed Large] A2
47	20	4,5	14,6	16,7	-
52	25	4,6	14,6	17,2	27,5
62	30	5,9	20,4	23,3	35,7
72	35	6,4	19,5	23,2	-
80	40	6,6	22,3	26,2	-

### Nut and Bolt



Color	Color Code
White	(W)
Blue	(B)
Black	(S)

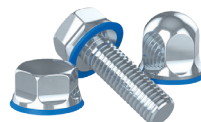

# XBPBC

## Certified Hygienic Bearing Houses

The design and patent protected XBPBC 2-hole block full bearing house is the optimal choice for machinery and equipment that has to comply with strict hygiene requirements. The XB4FC bearing house is mounted parallel to shaft direction

The XBPBC is designed to provide easy access for cleaning from all angles. We recommend that you choose a bearing house with NGI's hygienic nuts and bolts for maximum hygienic safety.

The XB4FC meets the requirements of EC 1935/2004, EC 10/2011, EC 2023/2006 and FDA.



-  Certified Hygienic
-  Minimized Cleaning Time
-  Minimized Water Usage

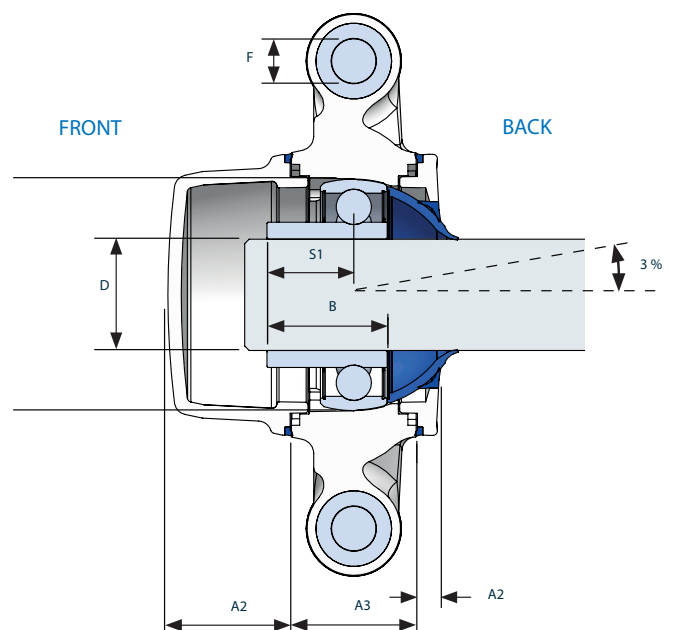
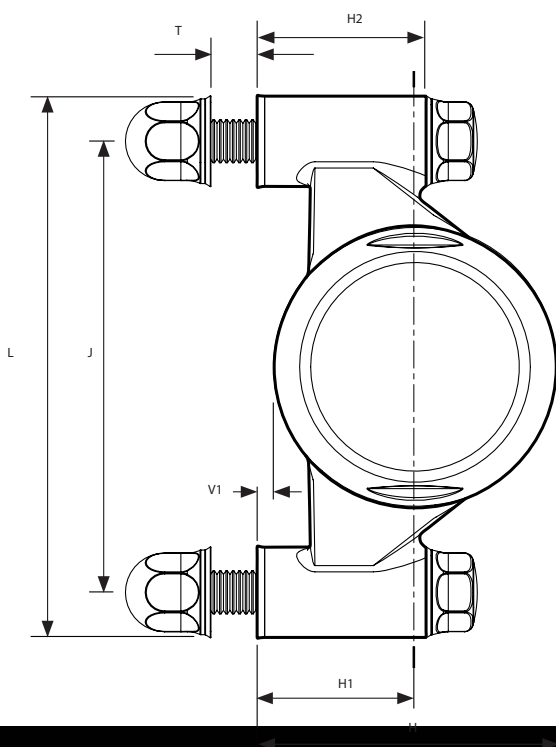



Product code	Bearing house	Bearing type	Front cover	Back cover	Bolt (optional)
EXAMPLE	XB4FC52-	SSB2500-	CL(W)-	OS(W)-	BXHM1050

### Bearing House



Size A [mm]	Shaft Diameter D [mm]	V1 [mm]	J [mm]	F [mm]	H [mm]	H1 [mm]	H2 [mm]	L [mm]	A3 [mm]	Item Code
47	20	4,4	96	10,2	62,2	33,3	36	117	24	XPBPC47
52	25	3,6	105	10,2	69,4	36,5	39	126	28	XPBPC52
62	30	3	121	10,2	82,8	42,9	41,5	146	29	XPBP062
72	35	1,8	126	12,2	93,4	47,6	46,5	152	33	XPBPC72
80	40	-	-	-	-	-	-	-	-	XPBPC80

### Bearing Type



Bearing Ball Material	Shaft Diameter D [mm]	Width B [mm]	Distance S1 [mm]	Maximum Speed Sealing [R/Min]	Static Load Rating C <sub>0</sub> [N]	Dynamic Load rating C [N]	Item Code
Stainless steel w. screws	20	25	18	1875	5040	10370	
Stainless steel w. screws	25	27	19,5	1500	5970	11310	SSB2540
Stainless steel w. screws	30	30	22	1250	8640	15730	SSB3175
Stainless steel w. screws	35	34	24,5	1070	11680	20830	-
Stainless steel w. screws	-	-	-	-	-	-	-

### Cover



Size A [mm]	Shaft Diameter D [mm]	OS [Open Small] A2	OM [Open medium] A2	CM [Closed Medium] A2	CL [Closed Large] A2
47	20	4,5	14,6	16,7	-
52	25	4,6	14,6	17,2	27,5
62	30	5,9	20,4	23,3	35,7
72	35	6,4	19,5	23,2	-
80	40	6,6	22,3	26,2	-

### Nut and Bolt



Color	Color Code
White	(W)
Blue	(B)
Black	(S)



CeramicSpeed Bearings A/S  
Noergaardsvej 3  
7500 Holstebro  
Denmark

 +45 97 40 25 44

 [industry@ceramicspeed.com](mailto:industry@ceramicspeed.com)



**CERAMICSPEED**