

Quadratec® Aluminum Front Bumpers

Installation Manual for '07-'18 Wrangler JK Vehicles

#12057.0263 and 12057.0264

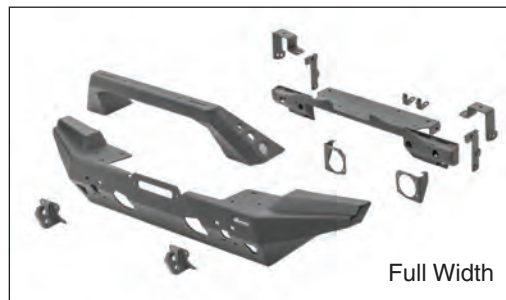

⚠ WARNING ⚠

TO REDUCE RISK OF SERIOUS INJURY OR PROPERTY DAMAGE: READ ALL SAFETY MESSAGES AND UNDERSTAND ALL INSTRUCTIONS AND PROCEDURE *NOTICES* BEFORE ATTEMPTING TO INSTALL OR USE THIS PRODUCT.

⚠ WARNING ⚠

MOUNT WINCH USING ONLY APPROVED MOUNTING PLATE. BUMPER/WINCH PLATE NOT INTENDED FOR WINCHES IN EXCESS OF 10000LBS. LOAD LIMITS FOR YOUR BUMPER/WINCH MAY BE LESS DEPENDING ON CONDITION OF YOUR VEHICLE AND ATTACHMENTS. FOLLOW ALL INSTRUCTIONS, LIMITATIONS & WARNINGS WITH YOUR VEHICLE, THIS PRODUCT, YOUR WINCH AND SAFE WINCHING PRACTICES SUPPLEMENT.

⚠ CAUTION ⚠

RISK OF EYE INJURY! SAFETY GLASSES MUST BE WORN AT ALL TIMES WHILE INSTALLING OR MAINTAINING THIS PRODUCT. TORQUE AND RECHECK FASTENERS AFTER 250 MILES AND FREQUENTLY THEREAFTER. INSPECT BUMPER, WINCH AND MOUNT BEFORE USE. DO NOT USE IF DAMAGED.

NOTICE

CHECK STATE AND LOCAL HIGHWAY SAFETY LAWS REGARDING PERMITTED BUMPER TYPES AND HEIGHTS.



The Trusted Source

A Few Words About Product Safety:

Your Quadratec® Aluminum Front Bumper is intended to enhance the utility and enjoyment of your off road capable vehicle. Before installation, please review the following safety information and installation recommendations.

Throughout these instructions important safety information is generally preceded by one of three signal words indicating the relative risk of injury, property damage or adverse consequence. **The signal words mean:**

⚠ WARNING ⚠

a hazardous situation which, if not avoided, could result in death or serious injury. You CAN be KILLED or SERIOUSLY HURT if you don't follow instructions.

⚠ CAUTION ⚠

a hazardous situation which, if not avoided, could result in minor or moderate injury. You CAN be moderately HURT and also may suffer property damage if you don't follow instructions.

NOTICE

Careful attention is required to this instruction or operation but does generally not relate to personal injury. Damage to your Quadratec® product or other property may result if you don't follow instructions.

Before You Begin Installation:

Congratulations on your purchase of Quadratec® Aluminum Front Bumper for your Jeep® Wrangler or Gladiator. This custom fit front Bumper has been designed for long life and a great look. Though constructed of only the finest materials, this bumper must be maintained to keep its look while performing under the toughest conditions.

Please see page 10 for important care & maintenance tips to keep your bumper looking like new. When unpacking, check to make sure all parts are included and not damaged due to shipping. If any part is missing or broken, please call Customer Service at 800-745-6037 as soon as possible. Thank you again for your purchase and let's start the installation process.

NOTICE

AS YOU UNPACK YOUR FRONT BUMPER, BE CAREFUL NOT TO SCRATCH THE FINISH WITH A KNIFE OR RAZOR. WE SUGGEST PLACING THE UNPACKED BUMPER BACK INTO THE ORIGINAL BOX SO IT DOES NOT GET SCRATCHED BEFORE THE INSTALLATION BEGINS. THIS BUMPER HAS A CUT-OUT FOR A VEHICLE RECOVERY WINCH. THE BUMPER FEATURES AN INTEGRATED WINCH MOUNTING PLATE.

⚠ CAUTION ⚠

WELDED FRONT BUMPERS ARE HEAVY AND WE STRONGLY SUGGEST THE ASSISTANCE OF AN ABLE-BODIED ASSISTANT DURING LIFTING AND INSTALLATION OF YOUR BUMPER.

⚠ CAUTION ⚠

READ ALL SAFETY MESSAGES AND ALWAYS WEAR SAFETY GLASSES WHEN WORKING WITH TOOLS.



The Trusted Source

Quadratec Aluminum Front Bumper Parts & Tools:

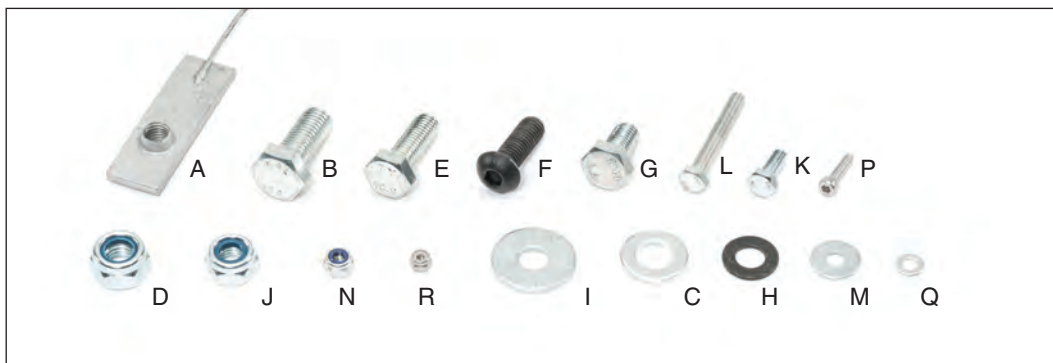
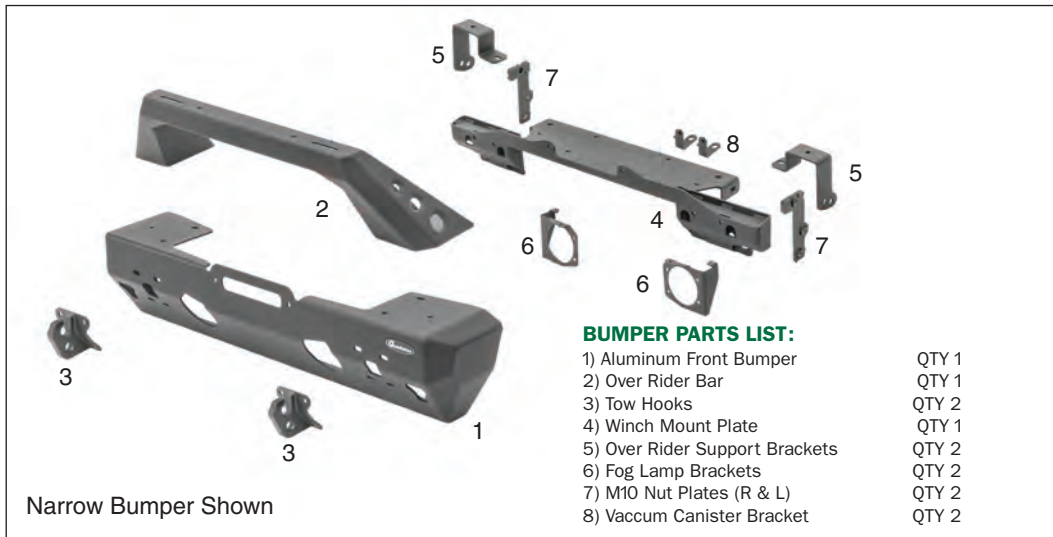

HARDWARE LIST: Packet 12057.9261

- | | |
|-------------------------------------|--------|
| A.) M10 Nut Plate w/Tether | QTY 2 |
| B.) M12 x 30mm Hex Bolt | QTY 8 |
| C.) 12mm Flat Washer | QTY 16 |
| D.) 12mm Nylock Nut | QTY 8 |
| E.) 10mm Hex Bolt | QTY 2 |
| F.) M10 x 30 Button Head Allen Bolt | QTY 16 |
| G.) M10 x 20 Hex Head Bolt | QTY 8 |
| H.) 10mm Flat Washer | QTY 24 |
| I.) 10mm Fender Washer | QTY 8 |
| J.) 10mm Nylock Nut | QTY 6 |
| K.) M6 x 16 Hex Head Bolt | QTY 4 |
| L.) M6 x 30 Hex Head Bolt | QTY 2 |
| M.) 6mm Flat Washer | QTY 8 |
| N.) 6mm Nylock Nut | QTY 4 |

- | | |
|-----------------------------------|--------|
| P.) M4 x 16 Socket Head Cap Screw | QTY 8 |
| Q.) 4mm Flat Washer | QTY 16 |
| R.) 4mm Nylock Nut | QTY 8 |

REQUIRED TOOLS:

- Safety Glasses
- 17, 18mm, 19mm Deep Sockets
- 10mm Socket
- Extension & Ratchet
- 7, 10, 17, 19mm Box End Wrenches
- T-20 Torx Driver
- 3mm & 6mm Allen Hex Key Wrenches
- Flat Blade Screwdrivers
- Forked Clip/Trim Removal Tool
- Torque Wrench (ft lbs)



The Trusted Source

JK Front Bumper Installation Preparation:

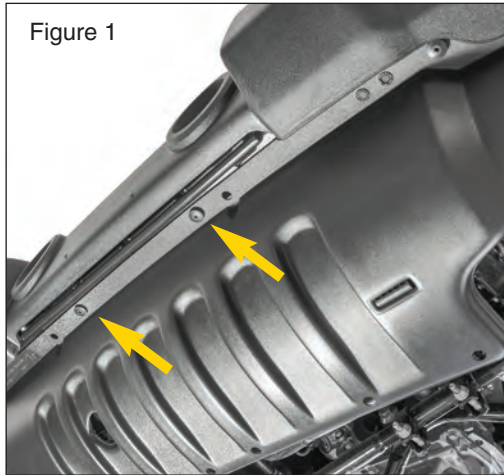

Put on safety glasses. Start by removing the factory splash guard. Remove the 4 plastic push rivets on the underside of the bumper. (FIG1)

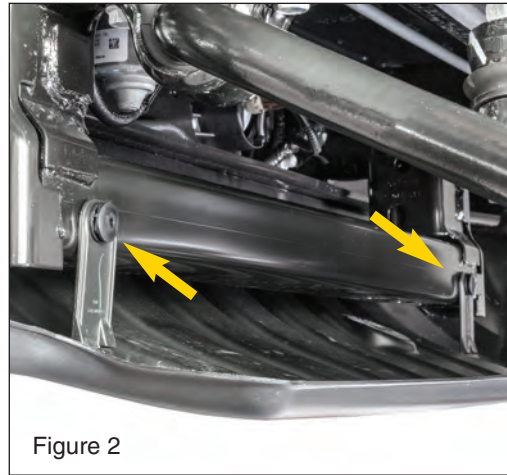

Next, remove the two plastic push rivets on the backside. (FIG2) Remove the splash guard. Note: This will not be reused with your Quadratic bumper.

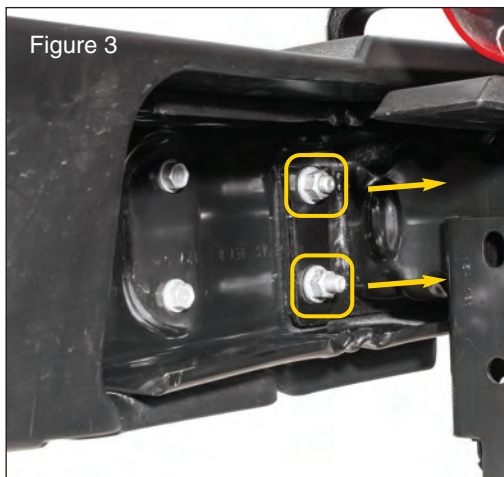

Next remove the factory bumper. Using an 18mm socket remove the 8 bumper retaining bolts. There are 2 on the inside and outside of each frame rail. (FIG3) Carefully remove the bumper from the frame rails.

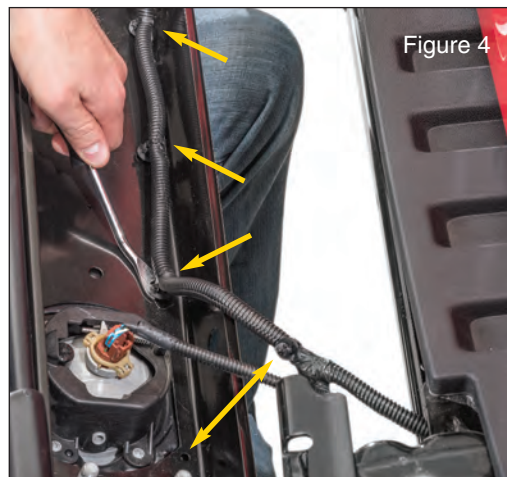

Be careful not to damage the fog light harness. Use a forked pry tool to remove the harness retaining clips from the backside of the bumper. (FIG4)



The Trusted Source

JK Front Bumper Installation Preparation:



Disconnect the factory wiring harness from the bumper mounted fog lights. (FIG5)

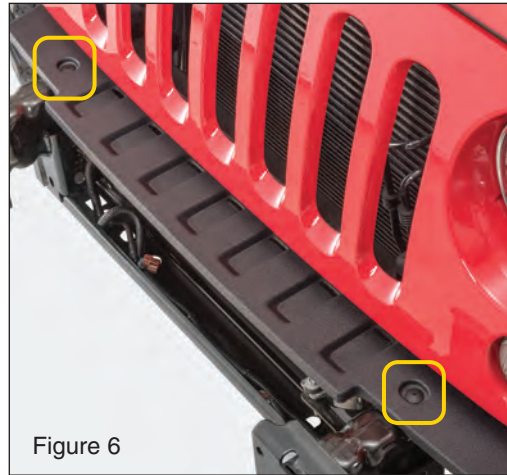

Next, remove the Factory frame guard. Locate the plastic screw rivets on either side. (FIG6)



Remove the plastic screw rivets with a phillips screwdriver. (FIG7)

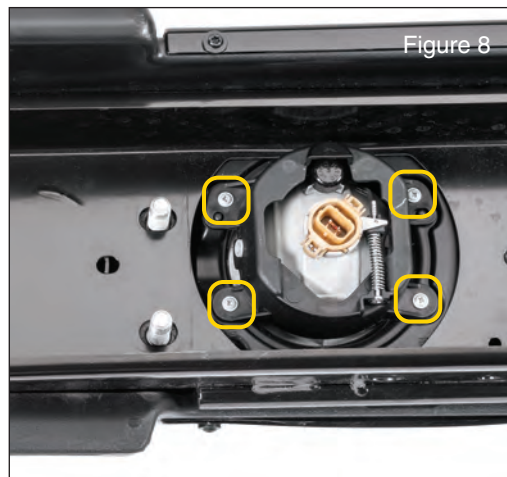

Now remove the factory fog lights from the factory bumper with a phillips screwdriver. (FIG8) Save factory fog lights for installation into the new Bumper.



The Trusted Source

JK Front Bumper Installation Preparation:



On 2012 and newer models locate and remove the mounting hardware for the brake vacuum canister using 10mm socket or wrench. (FIG 9)



Slide down the green tab and slide off the large hose. (FIG 10)



Pull of the small breather hose by pulling downward. (FIG 11)



Carefully set canister out of the way. (FIG 12)



Install the canister brackets to the winch mount as shown with M6 washers and lock nuts using a 10mm socket. (FIG 13) This is shown upside down for illustration purposes.

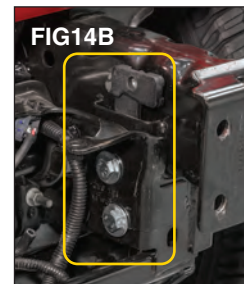

Loosely install the left and right nut plates to the inside of frame rails with the M10 x 20 Bolts and fender washers using a 17mm socket. (FIGs 14 A&B)



The Trusted Source

JK Front Bumper Installation:



Loosely install M10 x 20 Bolts and fender washers through the winch plate and into the nut plates using a 17mm socket. (FIG 15)

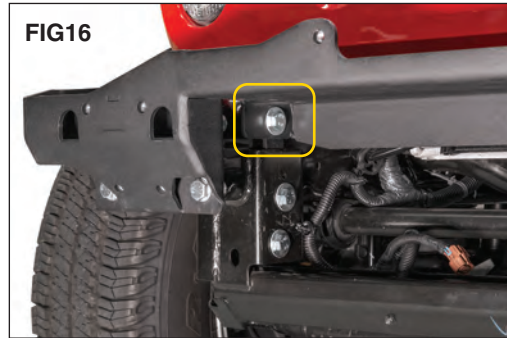

Loosely install M10 x 20 Bolts and fender washers through the winch plate and into the nut plates using a 17mm socket. (FIG 16)



Mount the vacuum canister with the included M6 x 30 bolts, M6 washers and nuts on the bottom as shown using a 10mm socket and wrench. (FIG 17) Carefully route the hoses best as possible and reconnect them to the canister.



Loosely install the over rider support bracket to the outside of frame rails using M10 x 20 Bolts, fender washers and nut plates with tether. (FIG 18)



Loosely secure the support brackets to the winch mount using (2) 10mm hex head bolts, 4 washers and 2 nylock nuts. (FIG 19)

Now tighten the (8) 12mm bolts on front of frame horns to **64 ft/lbs.** Next, tighten the M10 inner frame rail bolts to **38 ft/lbs.**



The Trusted Source

JK Front Bumper Installation:

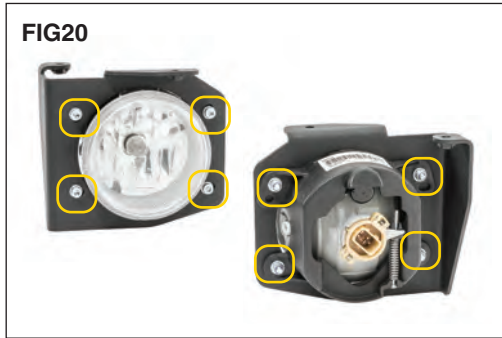

Attach the fog lamps to the brackets as shown with the supplied M4 hardware using a 3mm hex key and 7mm wrench. (FIG 20)

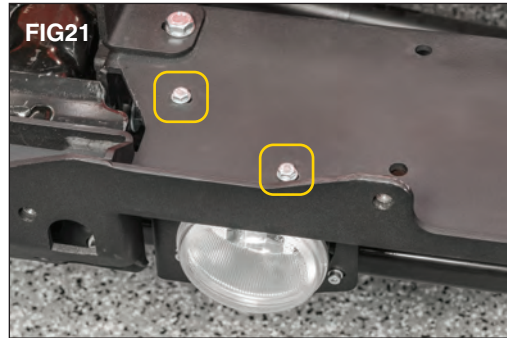

Secure the fog lamp brackets to the winch plate with the supplied M6 bolts and washers using a 10mm socket. (FIG 21)

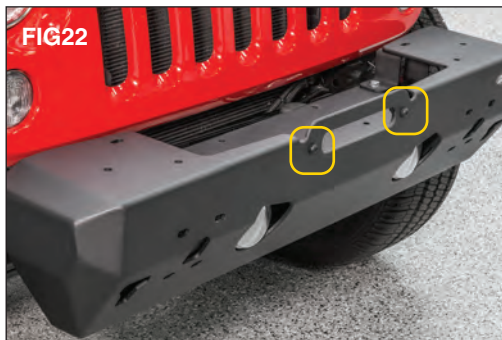

Loosely secure bumper to winch plate with 2 – M10 allen head bolts and washers using a 6mm hex key through the fairlead mounting holes. (FIG 22)

These bolts will be later used to attach your winch fairlead.



Loosely install the tow hooks through the bumper and into the winch plate with the supplied M10 allen head bolts and washers using a 6mm hex key. (FIG 23)

If you are Installing a Winch:

Now is a good time to install your winch and fairlead into the bumper according to your winch installation instructions.



The Trusted Source

JK Front Bumper Installation:



Loosely install the over rider bar through the bumper and into the support brackets with two M10 allen head bolts and washers using a 6mm hex key. (FIG 24)

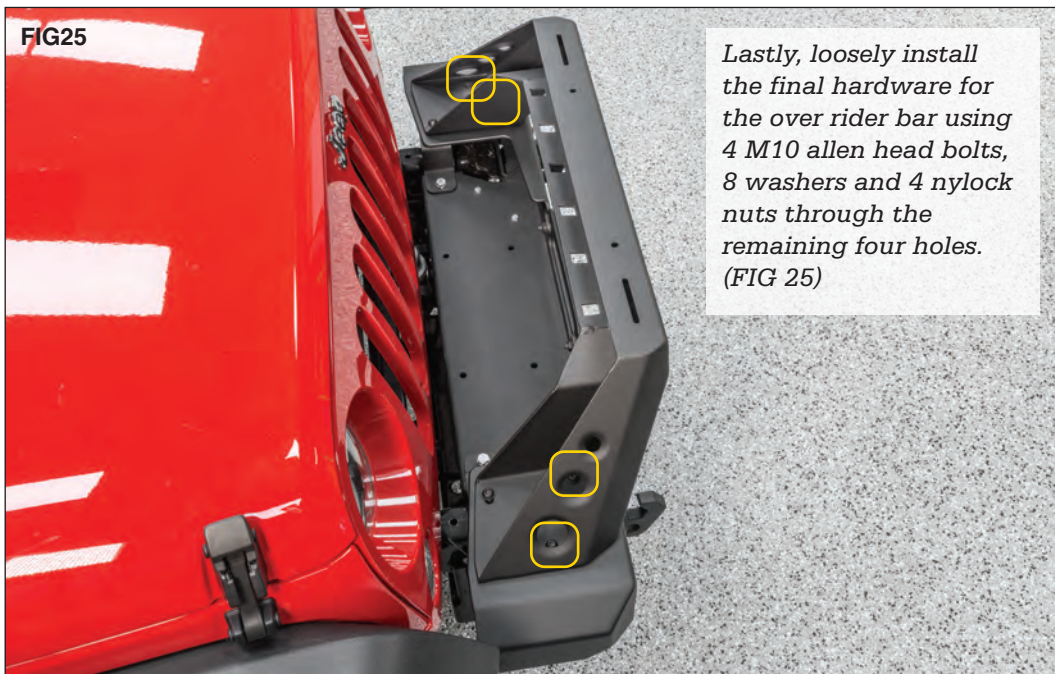

Lastly, loosely install the final hardware for the over rider bar using 4 M10 allen head bolts, 8 washers and 4 nylock nuts through the remaining four holes. (FIG 25)



The Trusted Source

Final Adjustments:



Final Adjustment:

You may now tighten the M10 allen head hardware through the tow hooks to 55ft lbs. Torque the over rider bar bracket to winch plate Hex Head M10 hardware and bracket to outside of the frame rail to 38ft lbs.

Now torque the remaining over rider bar M10 mounting hardware to 38ft lbs.

Installation is now complete.

Bumper Care:

Your Bumper has been designed and manufactured to provide years of use. However, like any product, general maintenance is required to keep it looking new.

Since the bumper is located on the front of the vehicle, it is subject to potential rock chips and other debris potentially causing portions of the paint to chip off. We recommend using a textured or gloss black spray paint sprayed on a piece of cardboard and Q-Tip to gently fill in

these chips. This will prevent any corrosion from forming. On all bumpers there is a chance of some surface corrosion showing over time due to metal particles being embedded in the paint. This surface corrosion is easily removed by a non-abrasive cleaner/polish and a soft bristle brush (not a metal brush!).

For bumpers with a textured finish, wash only with soapy water and avoid other waxes and polishes.



The Trusted Source

Final Results:



Narrow Width Shown installed with the Quadratic Q-Performance Stealth Winch (sold separately)



Full Width Shown installed with the Quadratic Q-Performance Stealth Winch (sold separately)



The Trusted Source

Quadratec® Exclusive Three Year Limited Warranty

Your Quadratec® branded accessories are covered by the following **Limited Warranty** provided exclusively by Quadratec, Inc., 1028 Saunders Lane, West Chester PA 19380.

This **Limited Warranty** is the only warranty made in connection with your purchase. Quadratec neither assumes nor authorizes any vendor, retailer or other person or entity to assume for it any other obligation or liability in connection with this product or **Limited Warranty**. This **Limited Warranty** does not apply and is not cumulative to any accessory or part distributed by Quadratec for which the Manufacturer provides a separate written warranty.

What is Covered: Subject to the terms, exclusions and limitations herein and with respect only to Quadratec branded accessories first sold in the United States, Quadratec warrants to the initial retail purchaser only that your Quadratec accessory shall be free of defects in material and workmanship: **for a period of three (3) years from date of retail purchase.**

This **Limited Warranty** is not assignable and shall terminate upon sale of the vehicle upon which the Quadratec accessory is installed or other transfer third persons.

All other warranties are hereby disclaimed, except to the extent prohibited by applicable law in which case any implied warranty of merchantability or fitness for a particular purpose on this product is limited to 3 year from date of initial retail sale. Quadratec reserves the rights to: (a.) require invoice or other proof your accessory is within the terms of this **Limited Warranty** as a condition of warranty service and, (b.) make future revisions to this product and **Limited Warranty** without prior notice or obligation to upgrade your product.

What is Not Covered:
Your Quadratec **Limited Warranty** does not cover products or parts Quadratec determines to have been damaged by or subjected to:

(a.) installation damage, alteration, modification, combination with other parts, failure to maintain or improper repair or service, (b.) normal wear & tear, cosmetic damage or damage from moisture or water immersion, (c.) Acts of God, accidents, misuse, negligence, inadequate mounting or impact with vehicle(s), obstacles or other aspects of the environment, (d.) theft, vandalism or other intentional damage.

Remedy Limited to Repair/Replacement:
The exclusive remedy provided hereunder shall, upon Quadratec inspection and at Quadratec's option, be either repair or replacement of product or parts (new or refurbished) covered under this **Limited Warranty**. Customers requesting warranty consideration should first contact Quadratec to obtain a RGA number (610-701-3336). All labor, removal, shipping and installation costs are customer's responsibility.

Other Limitations - Exclusion of Damages - Your Rights Under State Law:

In consideration of the purchase price paid, neither Quadratec nor any independent Quadratec distributor/licensee are responsible for any time loss, rental costs, or for any incidental, consequential, punitive or other damages you may have or incur in connection with any part or product purchased. Your exclusive remedy hereunder for covered parts is repair/replacement as described above.

This **Limited Warranty** gives you specific rights. You may also have other rights that vary from state to state. For example, some states do not allow limitations of how long an implied warranty lasts and /or do not allow the exclusion or limitation of incidental or consequential damages, so the limitations and exclusions herein may not apply to you.

©Quadratec, Inc. 2019. All Rights Reserved.
A4 Version 11.12.19

Instructions Part #12999.3153



The Trusted Source