

# New World Station

## Instructions

### Main Structure:

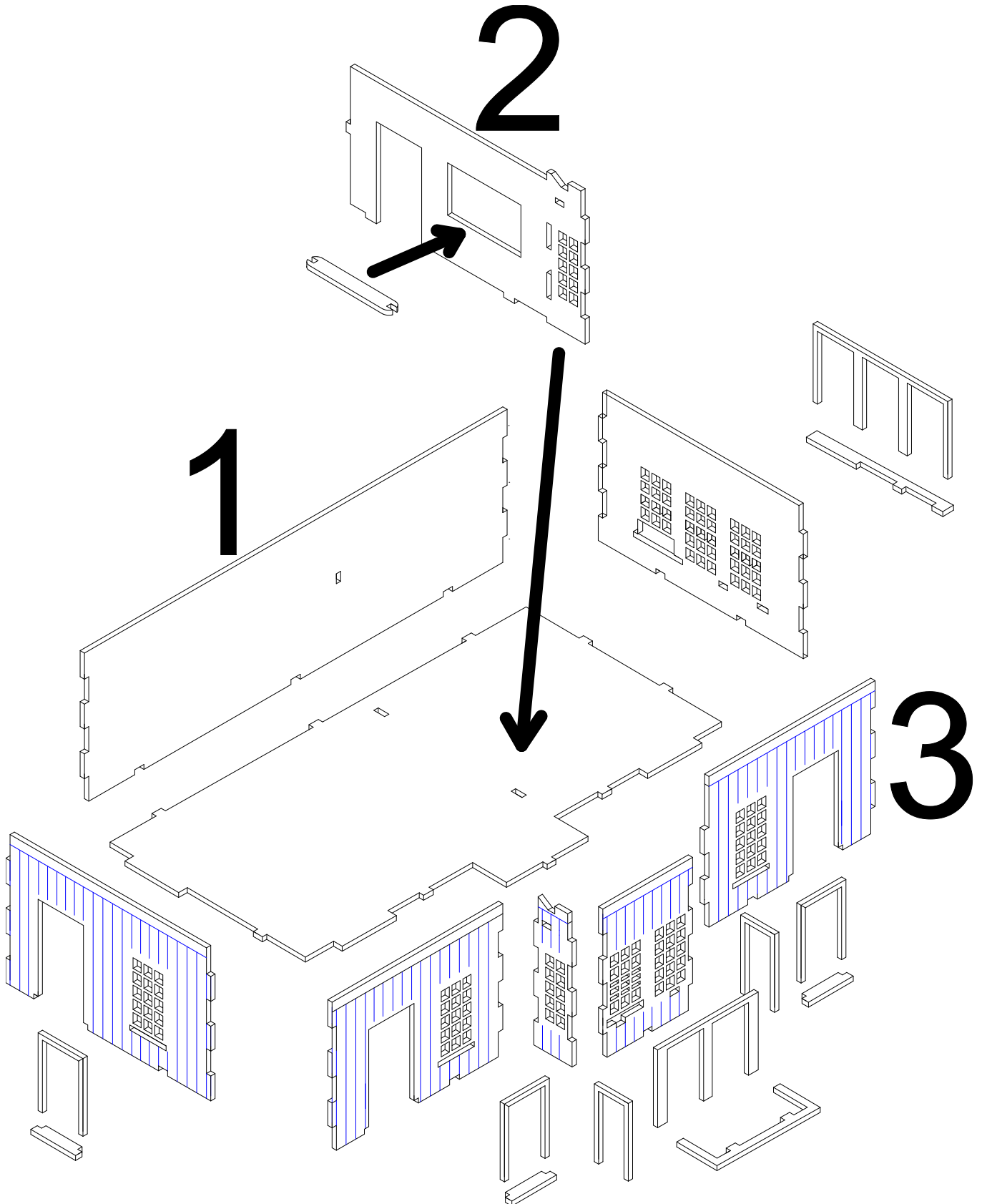

Always “dry run” parts before gluing with a woodwork quality PVA.  
Start with the ground floor piece and place the MDF on a flat surface.

Identify and position the walls around the perimeter of the base for ease of construction.

Select the jointed long interior wall (part 2) and glue in the counter. This piece should then be glued to the back wall (1) and front right(3), making an “h” shape. The sub assembly should then be glued to the base.

Glue on the two opposite short walls followed by the front left wall.

Next glue in the small wall section to the left of the bay window and while the glue is still wet, insert the small rectangular strengthening piece above the windows. This will make the piece more robust and aid you in ensuring the bay is square.

Glue on the front 2- window wall section to complete the bay.

Set this aside to dry and work on the roof. (See below for that instruction).

When the walls to the main building are dry insert the window sills into their respective slots and follow this with the window surrounds. Ensure that the base of the long sides line up with the window sill. When all windows have sills and frames glued on, remove the cardboard windows from the frame with a sharp craft knife and glue to the upper part of each window in turn.

To complete the main structure glue on the 3 external door frames ensuring that they line up with the protruding floor piece (doorstep).

## **ROOF:**

The roof pitch is shallow so the apex will have a wide gap. I have designed this out however to ensure a “best fit” it is recommended that the internal edges of the roof where the pieces meet are sanded down a fraction of a MM. This is best done with an emery board rather than sandpaper as the board will lessen the chance of “rounding off”. When the roof is fully assembled and dry, before the cardboard trim and chimneys are added it is recommended that the sanding is repeated on the top leading edge as indicated by the arrow on the next illustration.

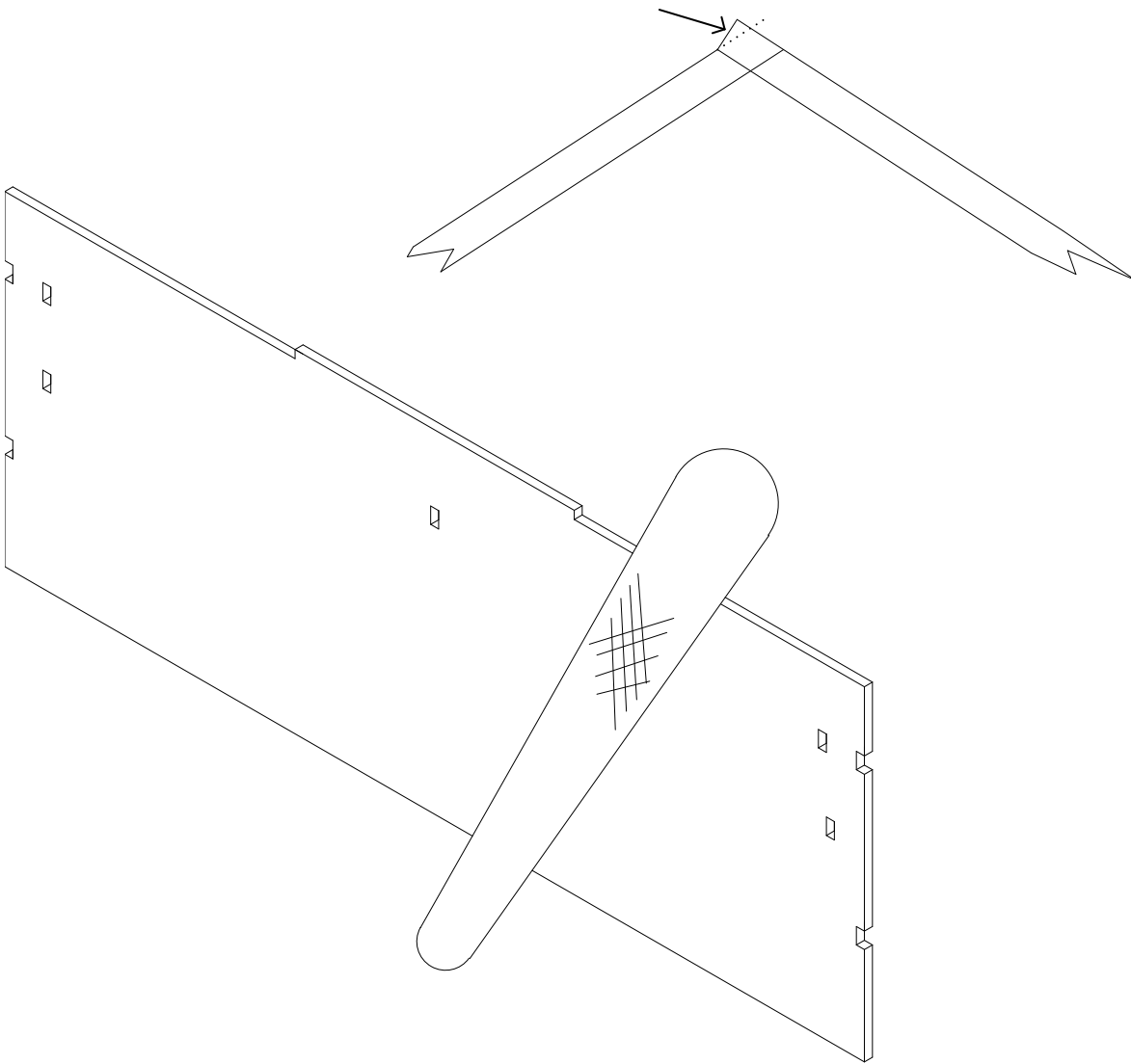

With the inner edges lightly sanded place one roof piece on a flat surface and glue in the 3 triangles. Next, align the 2<sup>nd</sup> roof piece and locate tab to recess. Glue the last triangle edges and close like a book to locate the three triangles into the holes in the roof. Press tightly together and set aside to dry.

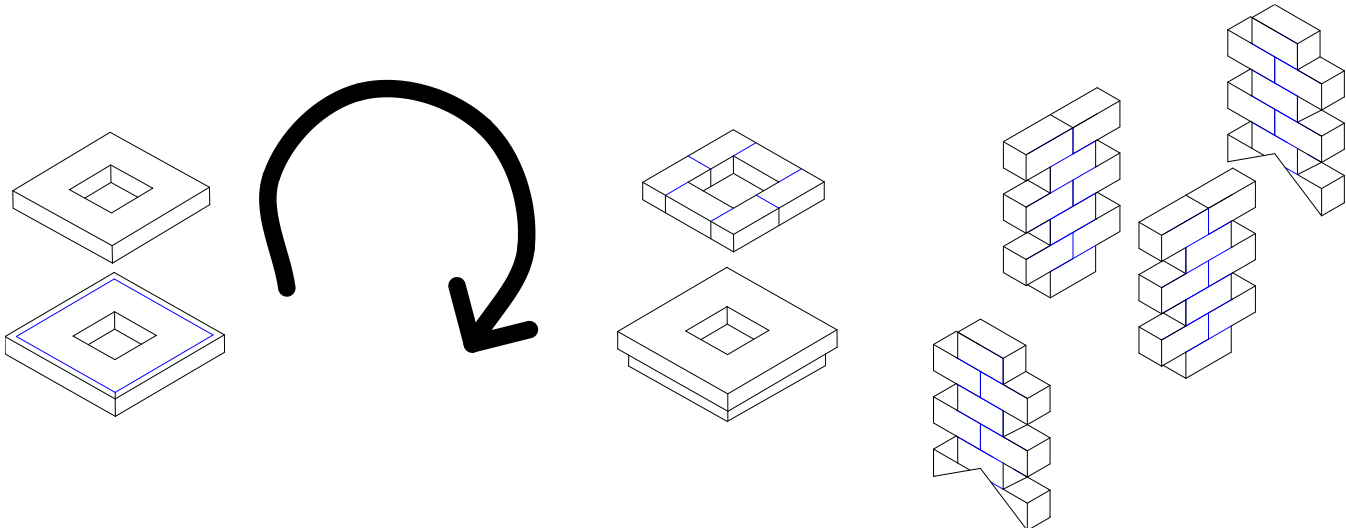
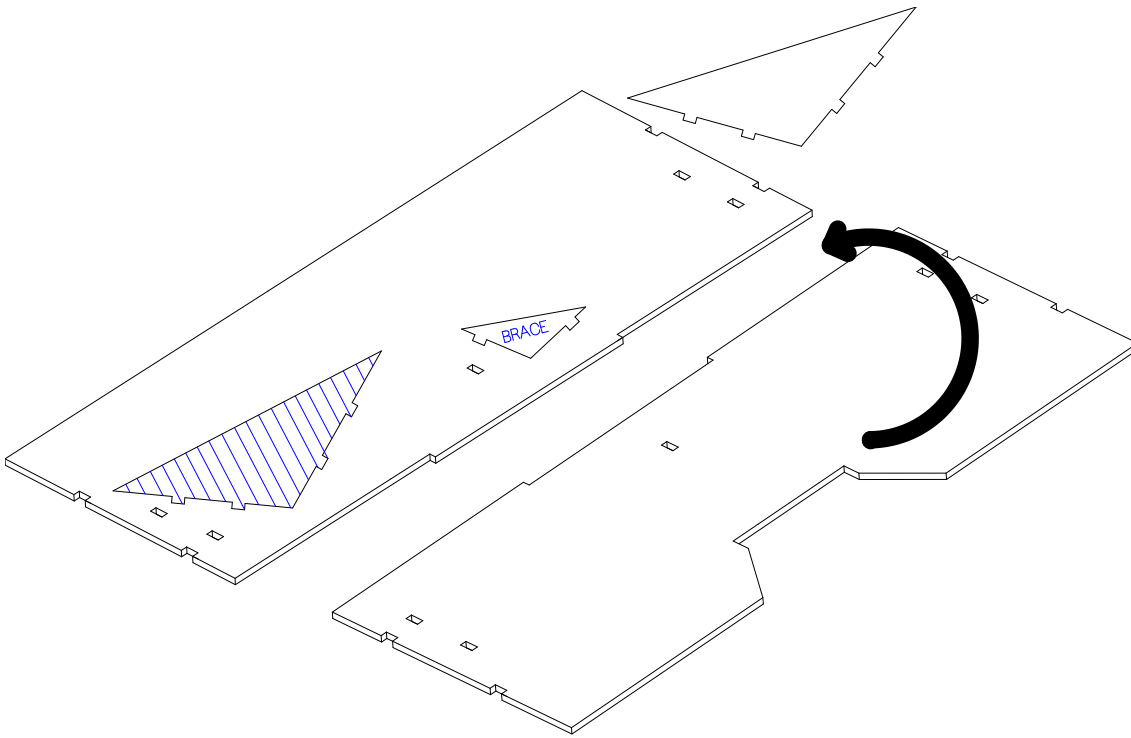

Glue the plain hollow square to the larger hollow square and use the engraved lines for positioning. When dry turn over and glue on the “brick” engraved chimney top and align by-eye to ensure it is centrally positioned.

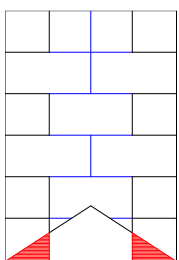

Glue the 4 chimney stack pieces together and when dry use a sharp craft knife to trim the inner edge so the stack aligns to the incline of the roof. Remove the red shaded area as indicated on the left image.

Next, glue on the first chimney top. Repeat for the second chimney.

NOTE: the chimney top pieces need to run the same way.

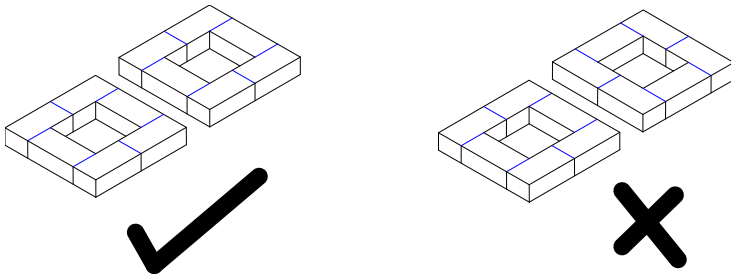

Glue ONE chimney to the roof where guidelines have been engraved. Fold and glue on the thin card ridge “planks” then glue on the second chimney. Fold and glue on the remaining two card “ridge planks”.



File or emery board the two triangles leading top edges (like the roof) then assemble. It is recommended that the front A frame trim is glued in at this time. This makes the sub-assembly 4 pieces in total.

**When dry, place fine grade sandpaper / glasspaper on a flat surface. Move the sub assembly roof across the abrasive paper and vary the direction of sanding.**

Check frequently you are keeping this stage even.

When fully sanded (it took me 3 minutes), the underside of the roof should look like this. The sanded area is wood colour with a fine line of laser burn along the outer edge.





Check your progress frequently so you do not over-sand the piece by resting on your flat surface.

Place the roof on the main building structure then glue on the V raised roof piece. Take care to align evenly to the recess in the roof piece and check to ensure it is central before the glue cures.



Remove the card trim from the frame and offer up to the main roof while resting the card on the apex of the V part. Using a sharp pencil, mark the incline and trim to fit.

Fold the card and mark the thinner "beams" and trim to lie flat to the roof. Repeat for all 4 then glue into place.



Remove the thin "beams" from the card frame and glue over the engraved lines. Ensure you have a good close fit at the top and allow the card to overhang the edge until dry.

Repeat this process until all engraved lines are covered and once dry trim off the overhangs with a sharp craft knife.





The roof would have been covered with tarred canvas. To gain an irregular surface to simulate tar applied by hand, I thinly spread some filler in between the card for texture. I used a wet finger to smooth and keep the layer thin.



When dry, I spray painted the model with grey primer. Note, I left the doors and gable end "A beams off for ease of painting.



Next, I spray primed (white) the doors, windows and A frames.



Next, I made paper rectangles to mask the white paint and held the masks in place with blu-tac. The 3<sup>rd</sup> spray was red oxide primer.

I masked the chimneys and gable ends of the roof and sprayed black.

The model looked table ready once the A frames and doors were glued in place.



The tabs of white were overpainted black and the roof dry brushed with grey to bring out the texture. This was followed by some grime wash (by Flory)

Vallejo Hull Red paint was watered down and used to shade the red primer.

Vallejo Hull Red & Artiste Dark Red mixed 50-50 is a very good match for the red primer. I used this to paint the small triangle of wood on the raised V behind the small front A frame. This mix is also good for blending the Hull Red shade.

Arctic Grey (Foundry) paint was used to shade, lighten the white woodwork as required.



**Charlie Foxtrot Models**

[www.charliefoxtrotmodels.com](http://www.charliefoxtrotmodels.com)