

Eastern Front Hunter's Lodge

Always "dry run" parts before gluing with a woodwork quality PVA.

Start with the floor and place the MDF on a flat surface.

Glue each of the 4 sides to the base and set aside to dry.

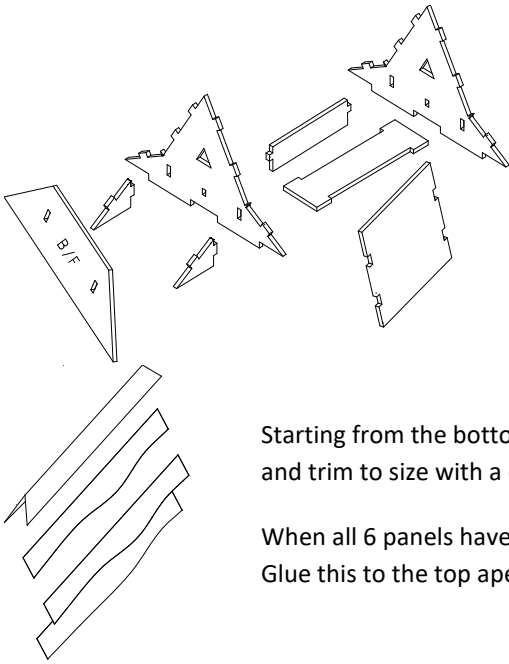

With the planked side out, glue the stretcher bar into the middle of the 3 holes, joining both triangular gable ends.

Glue both steep side roof parts to the gables.

Glue in "bone shaped" stretcher underneath the gables.

Fix the triangular roof supports to the 4 low pitched roof pieces.

Once dry; glue the 4 roof assemblies to the main roof structure.

Note: the L/R Left Right and B/F Back front sides are different. The B/F needs to align with the planked vertical side with the triangular window.

Starting from the bottom edge of each roof side, glue on the waney edged effect cardboard "planks" and trim to size with a craft knife when dry.

When all 6 panels have been clad, take the parallel sided strip with the "v" indents and fold lengthways. Glue this to the top apex seam and trim to fit once dry.

Thank you for buying this model from:

Charlie Foxtrot Models www.charliefoxtrotmodels.com