



AFINIA 3D™

User Guide

QD330

3D PRINTER

WARNING

-
1. Please refer to this Guide for initial printer setup.
 2. Hot! Avoid touching the heating nozzle in operation.
 3. Moving parts in the printer may cause injuries. Do not wear gloves or other sources of entanglement in operation.
-

Safety Notice

Do not power on the printer until installation is completed.

WARNING

This printer - when used with styrene filament (ABS / HIPS / PC-ABS) can expose you and others in the same room to styrene, a chemical known to the State of California to cause cancer.
www.P65Warnings.ca.gov

ALWAYS OPERATE THIS PRODUCT IN A WELL-VENTILATED AREA.

CONTENTS

Notice	02
1. Equipment Introduction	04
1.1 - Printer Components	04
1.2 - Printer Parameters	05
2. Initial Setup	06
2.1 - Unboxing	06
2.2 - Packing List	08
2.3 - Installing the Spool Holder	09
2.4 - Unlocking the Build Plate	10
2.5 - First Print	11
3. Software Introduction & Installation	14
4. Printing	16
4.1 - Filament Loading and Changing	16
4.1.1 - Filament Loading	16
4.1.2 - Filament Changing	16
4.2 - Network Connection	19
4.2.1 - Wireless Network Connection	19
4.2.2 - Wired Network Connection	19
4.3 - Printing Methods	20
4.3.1 - Printing via USB	20
4.3.2 - Printing via Wi-Fi transfer	20
4.3.3 - Printing via Cloud	21
4.4 - Camera Connection	23
4.5 - Model Removal After Printing	24
5. Introduction to Auxiliary Functions	24
5.1 - Leveling and Calibration	24
5.2 - Air Filtration	25
5.3 - Other Function Settings	25
6. Maintenance	26
6.1 - Suggestions on Platform Plate Usage	26
6.2 - Suggestions on Nozzle Usage	26
6.3 - General Maintenance	26
7. Q&A	27
8. Help and Support	30

NOTICE

SAFETY NOTICE: PLEASE CAREFULLY READ AND STRICTLY FOLLOW ALL THE SAFETY WARNINGS AND NOTICES BELOW ALL THE TIME.

Note: Each 3D printer undergoes printing tests before leaving the factory. Filament residue on the nozzle or slight scratches on the build plate are normal and do not affect usage.

WORK ENVIRONMENT SAFETY

- ◆ Please keep the workspace clean and tidy.
- ◆ Please ensure the equipment operates away from combustible gases, liquids, and dust. High temperatures generated during operation may react with combustible gases, liquids, or airborne dust, potentially causing fires.
- ◆ Children and untrained individuals should not operate the equipment alone.

ELECTRICAL SAFETY

- ◆ Please properly ground the equipment. Do not modify the plug. Ungrounded equipment/improperly grounded equipment/modified plug will inevitably increase the risk of electric leakage.
- ◆ Avoid exposing the equipment to damp or direct sunlight environments. Humidity will increase the risk of electric leakage. Exposure to sunlight will accelerate the aging of plastic parts.
- ◆ Make sure to only use the power cord provided by Flashforge.
- ◆ Do not use the equipment during thunderstorms.
- ◆ Please turn off the equipment and unplug it if it is not in use for a long time.

PERSONAL SAFETY

- ◆ Do not touch the extruder, build plate, etc., during printing.
- ◆ Do not touch the extruder and build plate after finishing printing to avoid high temperature burns or mechanical damage.
- ◆ Do not wear scarves, masks, gloves, jewelry, or other objects that can easily get tangled into the equipment while operating it.
- ◆ Do not operate the equipment while you are tired or under the influence of drugs, alcohol or medication.

CAUTIONS

- ◆ Keep the inside of the equipment clean. Do not drop metal objects into the grooves at the bottom of the build plate.
- ◆ Please clean up filament debris in time. It is recommended to operate this outside the equipment.
- ◆ Any modification of the equipment by yourself will void the warranty.
- ◆ Please keep the distance between the extruder and build plate for at least 50mm during filament loading. Too-close distance may cause nozzle clogs.
- ◆ Please operate the equipment in a well-ventilated environment.
- ◆ Do not use the equipment for illegal activities.
- ◆ Do not use the equipment to make food storage containers.
- ◆ Do not place printed models into your mouth.

EQUIPMENT ENVIRONMENT REQUIREMENTS

- ◆ Room temperature: 15-30°C; Humidity: 20-70RH%

EQUIPMENT PLACEMENT REQUIREMENTS

- ◆ The equipment must be placed in a dry and well-ventilated environment. A distance of at least 35cm must be reserved around the front, back, left and right sides of the equipment. Recommended storage temperature: 0-40°C

COMPATIBLE FILAMENT REQUIREMENTS

- ◆ When using this equipment, it's recommended to use Afinia's filaments. If non-Afinia filaments are used, there will be certain differences in material properties, and print parameters may need adjustments.

FILAMENT STORAGE REQUIREMENTS

- ◆ Please store filaments in a dry and dust-free environment after unpacking. It is recommended to use the matching filament dry box for storage.

LEGAL STATEMENT

- ◆ Users are not authorized to make any modifications to this User Guide. Afinia shall not be held responsible for any safety incidents resulting from the disassembly or modification of the equipment by the customer. No one is allowed to modify or translate this Guide without Flashforge's permission. This Guide is protected by copyright, and Flashforge reserves the right of the final interpretation of this Guide.
- ◆ First Edition (January 2024)
Copyright © 2023 Afinia 3D. All Rights Reserved.

1. Equipment Introduction

1.1 Printer Components

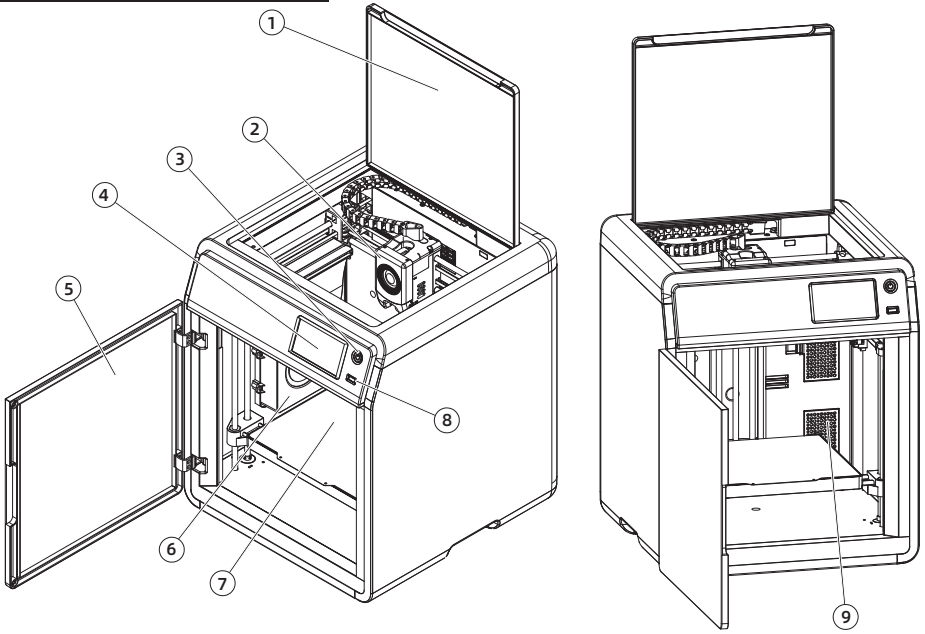

1. Top Cover
2. Extruder
3. Switch Button
4. Touch Screen
5. Front Door
6. Auxiliary Cooling Fan
7. Build Plate
8. USB Port
9. Air Filter
10. Screw Holes for Spool Holder
11. Ethernet Input
12. Power Switch
13. Power Socket

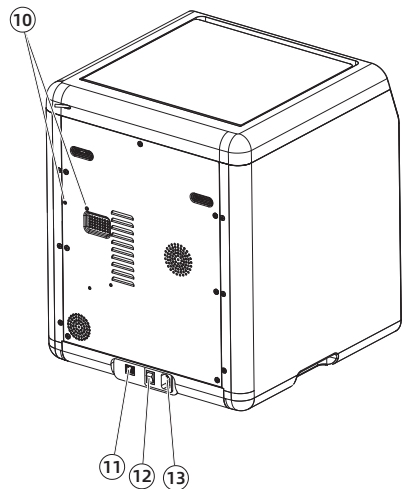

1.2 Printer Parameters

Machine Name	Afinia QD330
Extruder Quantity	1
Printing Precision	±0.2mm [testing based on 100mm cubes]
Positioning Accuracy	X/Y-axis: 0.0125mm; Z-axis: 0.0025mm
Layer Thickness	0.1-0.4mm
Build Volume	220 x 220 x 220mm
Nozzle Diameter	0.4mm [default]; 0.6/0.8/0.25mm [optional]
Printing Speed	10-300mm/s
Max. Acceleration	20000mm/s ²
Max. Travel Speed	600mm/s
Max. Extruder Temperature	280°C
Supported Filament	*PLA/*PETG/*TPU [0.4mm nozzle] ASA/ABS PLA-CF/PETG-CF [0.6/0.8mm nozzle] Note: Materials marked with * are recommended for printing.
Power Supply	Input: AC 100~240V, 50/60Hz, 350W
Device Size	380 x 400 x 453mm [excluding the spool holder]
Net Weight	14.6kg
Connectivity	USB/Wi-Fi/Ethernet
Operating Temperature	15-30°C
Compatible Operating System	Windows 7/8/10/11; Linux: Support version Ubuntu 20.04 or later; Mac OS: Support version 10.9 or later.
Slicing Software	Afinia 3D Slicer
Max. Platform Temperature	110°C
Leveling Method	One-click auto leveling
Filament Run-out Reminder	√
Power Loss Recovery	√
Smart Touch Screen	4.3-inch
Remote Video Monitoring	√
Time-lapse Video	√
Air Filtration	Internal circulation + external circulation [HEPA + activated carbon]
Build Plate	PEI flexible steel plate
Automatic Shutdown	√

2. Initial Setup

2.1 Unboxing

Safety Notice: Do not power on the printer until installation is completed.

1. Open the box.

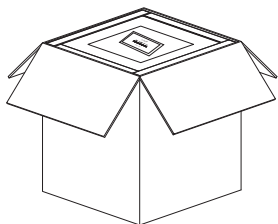

2. Remove the upper foam packaging, Quick Start Guide and After-sales Service Card.

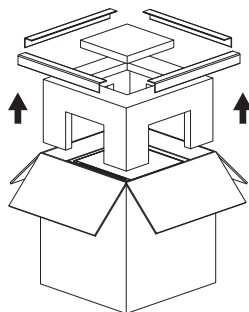

3. Take out the machine, place it on a level workspace and remove the packaging bags and tapes.

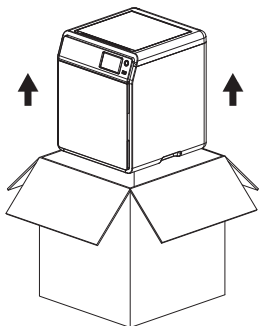

4. Open the top cover and remove the upper protective foam.

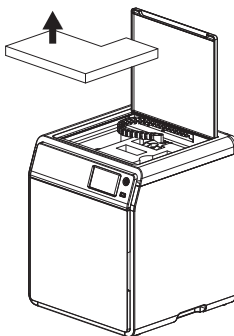

5. Remove the filament, power cable, and accessory box from the chamber protective foam. Remove the inner protective foam from the extruder.

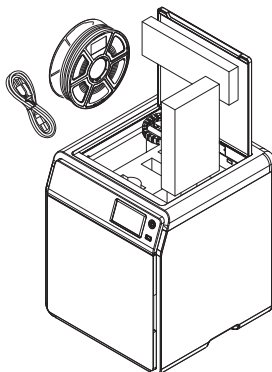

6. Move the extruder and chain according to the arrow direction.

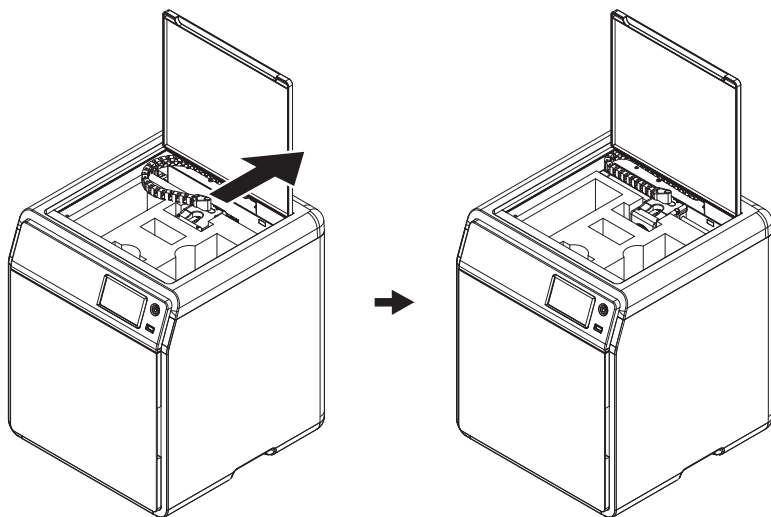

7. Remove the foam.

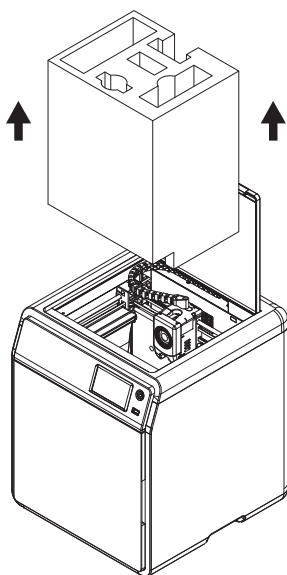

2.2 Packing List

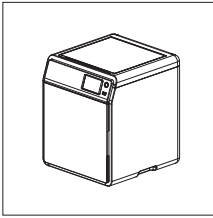

3D Printer

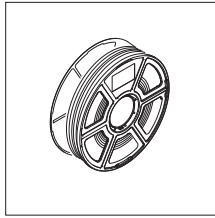

Filament

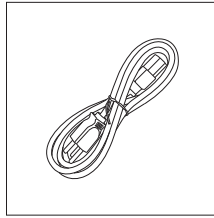

Power Cable



After-sales Service Card

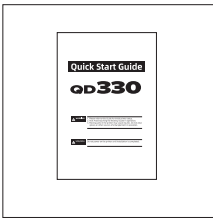

Quick Start Guide

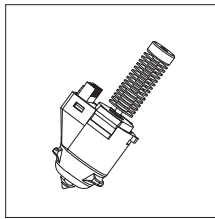

0.6mm Nozzle

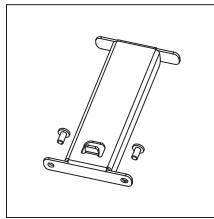

Spool Holder
(with 2 screws)

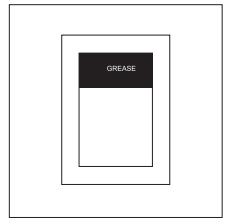

Grease

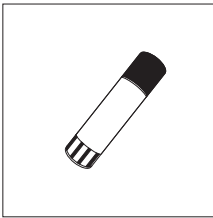

Glue

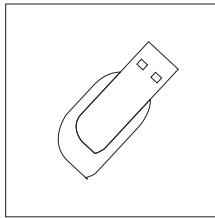

USB Disk

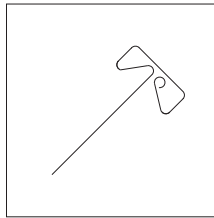

Unclogging Pin Tool

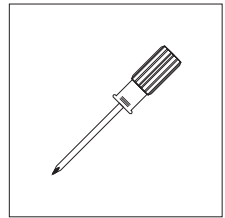

Screwdriver

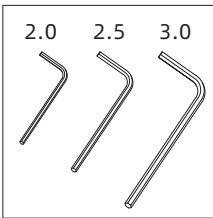

Allen Wrench

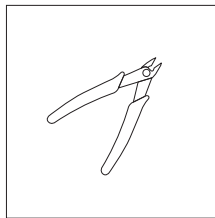

Diagonal Pliers

2.3 Installing the Spool Holder

1. Take out the two screws and spool holder from the accessory box.

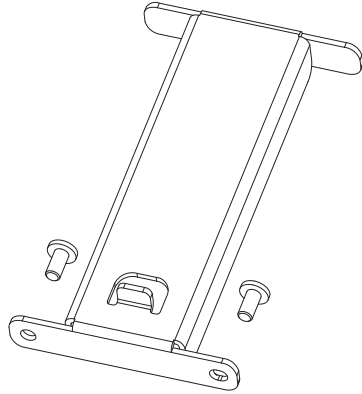

2. Install the spool holder at the position shown in the figure with the two screws.
(Note: Please tighten them using a 2.0mm Allen wrench.)

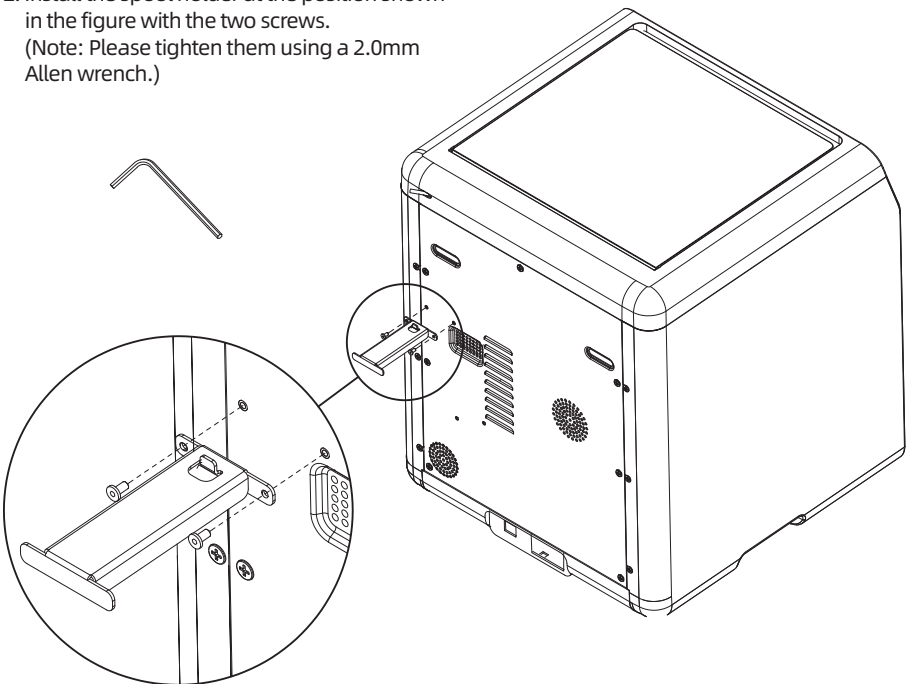

2.4 Unlocking the Build Plate

Note Please ensure the platform has been cleared up!

Please use a 2.0mm Allen wrench to remove four screws which lock the build plate (as indicated by the arrow).

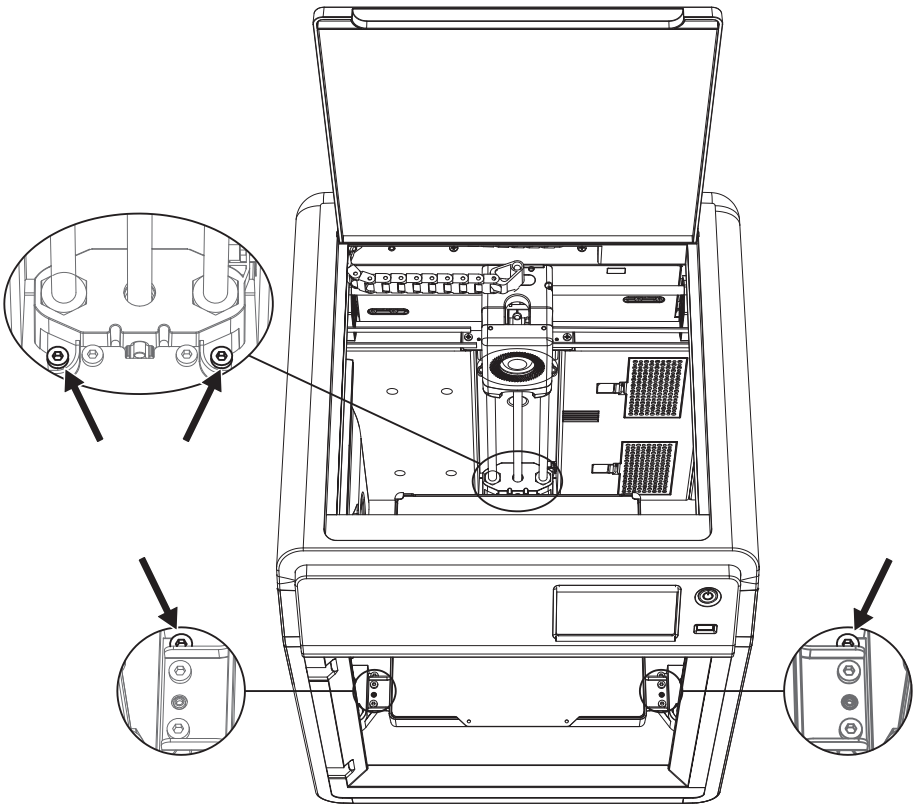

2.5 First Print

* The interface layout may change whenever there is an upgrade of firmware.

1. Connect the power, turn on the power switch, and press the switch button to turn on the screen.

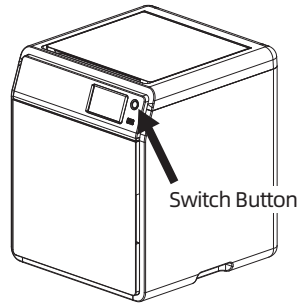
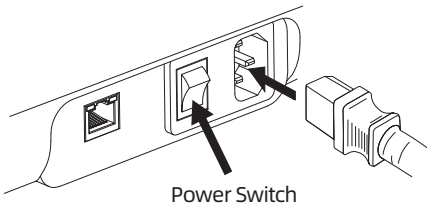

2. Following the guide on the screen, select the language.



3. Click [Next] according to screen prompts and the machine will perform the first calibration. Vibrations and noise during calibration are normal. (Note: Please keep the machine on a stable surface and do not move it during calibration.)

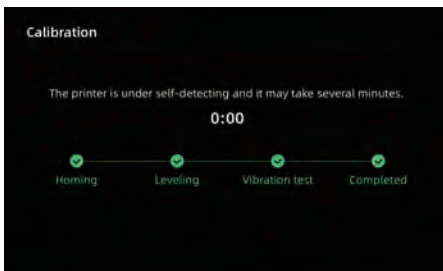
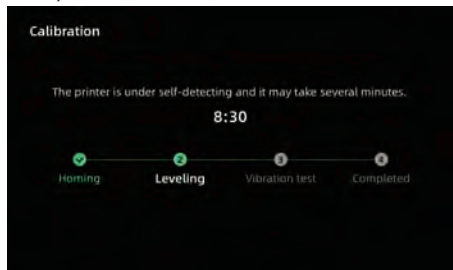

4. Load filament following the on-screen startup boot:



a. Cut off the bent part of the filament end.

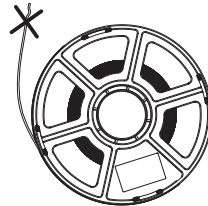

b. Hang the filament on the spool holder. Pass it through the filament sensor until it's seen from the other end of the filament guide tube. Push it forward to the feed roller, until it can not go further. (*Please use PLA filament for the first print on initial setup).

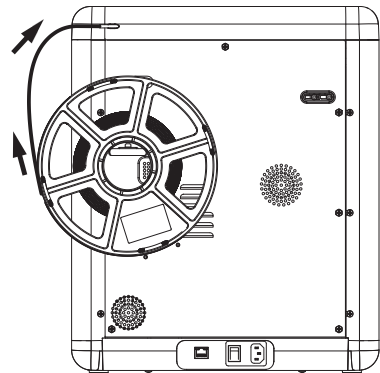

C1. Click [Load] and select [PLA] for the first print. C2. Wait for the extruder to heat up.



C3. Feeding will begin after heating. Successful filament extrusion from the nozzle indicates successful loading. Lastly, confirm the filament guide tube is properly inserted.

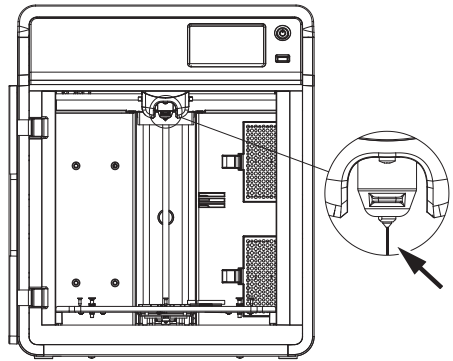
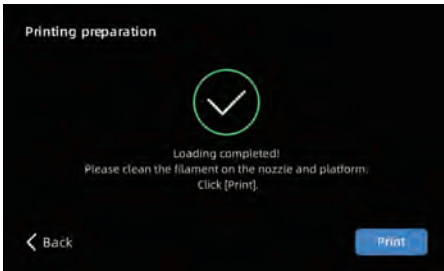

Note If no filament is extruded, manually insert the filament into the inlet and click [Back] to retry. Feel for filament movement until it is extruded.

5. Please clear the filament residues on the nozzle and platform. Users must apply glue to the platform so as to improve adhesion for the first print.

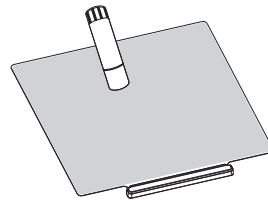

6. Click [Print] and the machine starts printing the built-in file (configured for PLA material).

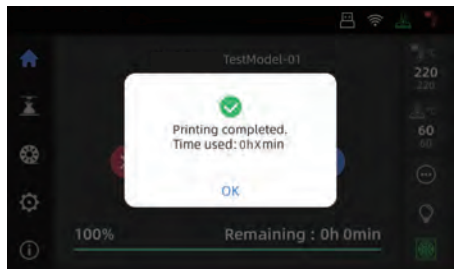

3. Software Introduction & Installation

Slicing instructions for Afinia QD330

Note Before reading the brief instructions, please ensure you have reviewed the Quick Start Guide and completed the first print.

Before printing 3D model files, you need to configure slicing presets for the corresponding printer. Recommended slicing software: Afinia 3D Slicer

Pre-printing Steps:

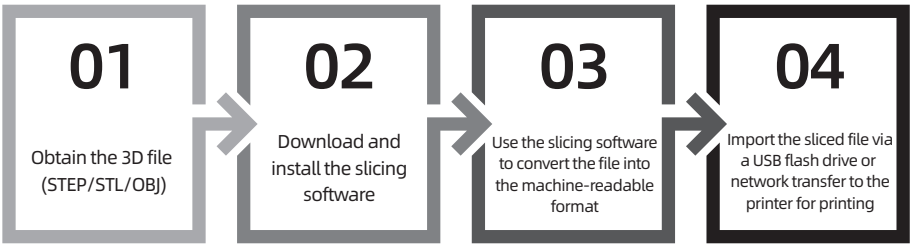

Afinia's Official Slicing Software - Afinia 3D Slicer

* The steps are illustrated for one machine type.

Afinia 3D Slicer is not open-source. It is user-friendly and suitable for users with no 3D printing experience or those who don't require parameter adjustments.

- Download Instructions**
1. Download the latest slicing software from the official website: <https://afinia.com/support/downloads/>
 2. Find the Afinia 3D Slicer software package on the USB flash drive and install the version that matches your system.

1. After installing the slicing software, import the model file.

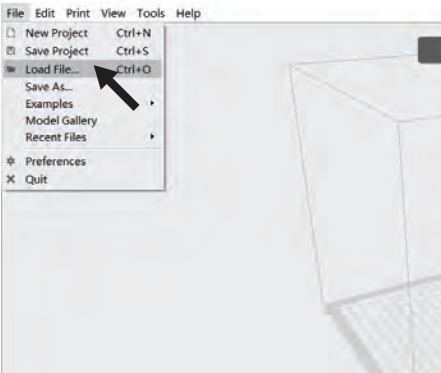

2. Select the corresponding printer type.



3. Click [Start Slicing] .



4. After slicing is completed, save the file to a USB flash drive for printing.



Note The slicing profiles available in A nia3D Slicer are configured based on extensive testing with various types of filaments. We recommend using the recommended temperature settings provided in the profiles. If you believe a specific filament requires a different temperature, you can make minor adjustments and print smaller objects at the set temperature for testing to ensure smooth operation.

4. Printing

4.1 Filament Loading and Changing

4.1.1 Filament Loading

Click [] to enter the filament loading interface and follow on-screen instructions to complete filament loading.

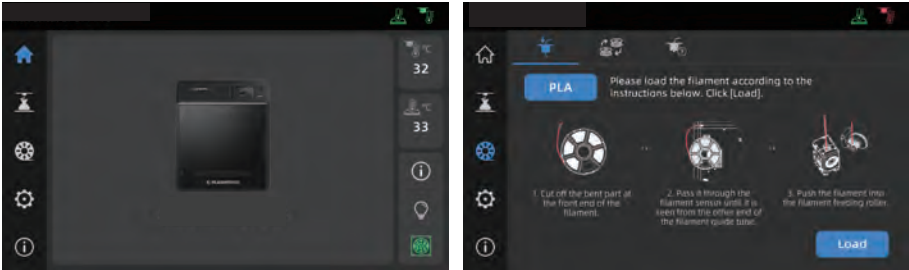

4.1.2 Filament Changing

1. Click  -  and follow on-screen instructions to complete filament changing.

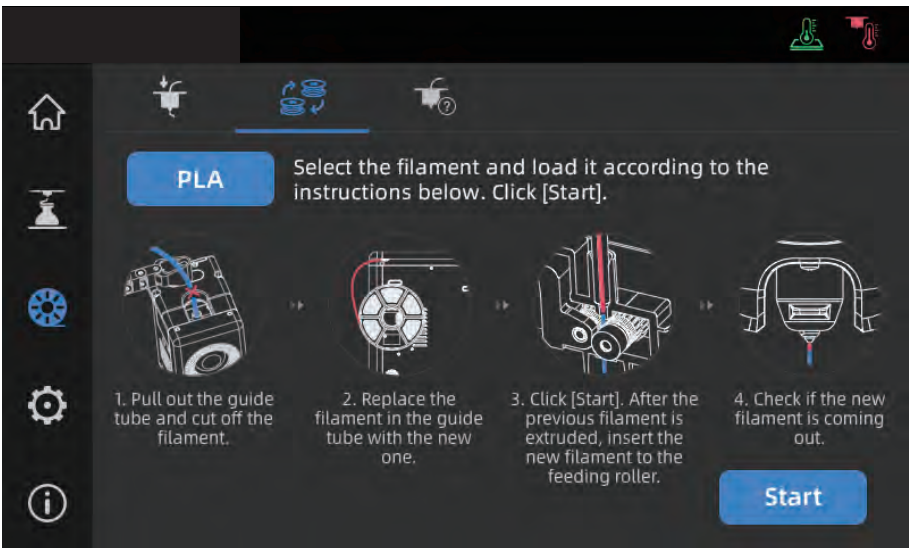

2. Pull out the filament guide tube as shown, and cut the filament.

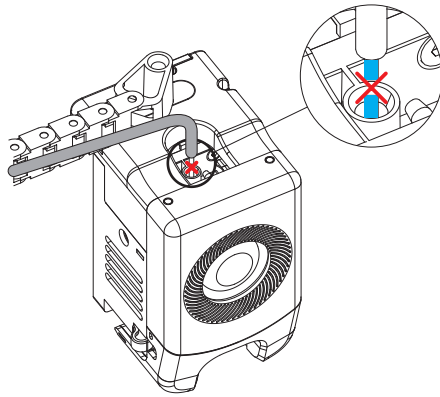

3. Pull out the cut filament, and insert the new filament into the filament guide tube. If the material type is changed, click [PLA] to select the corresponding material type.

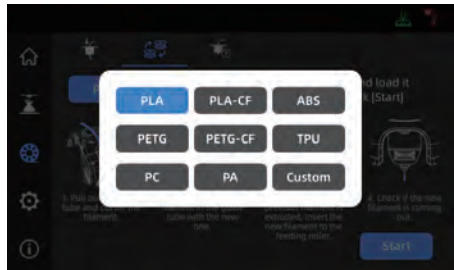
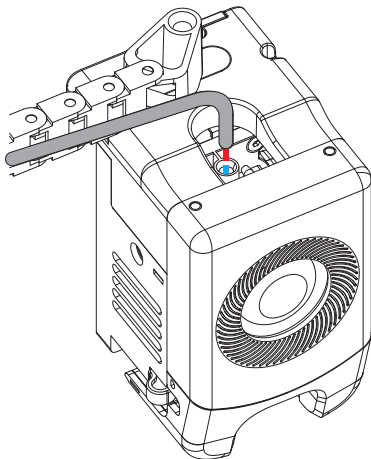
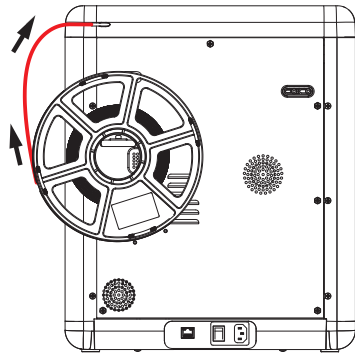
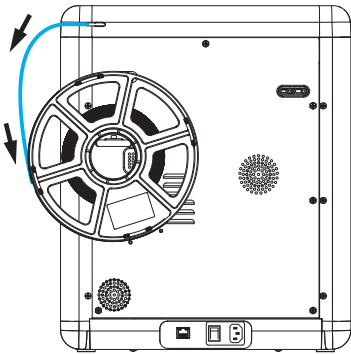

4. Click [Start], wait for the extruder to heat up and filament feeding will begin. When you see the previous filament is extruded, insert the new filament and observe its flow and the extrusion. If the new filament smoothly comes out of the nozzle, the filament change is successful. If not, hold the filament by hand, insert it into the inlet, and click [Again] to retry. Feel for filament movement until it is extruded. After successful loading, insert the filament guide tube into the inlet.

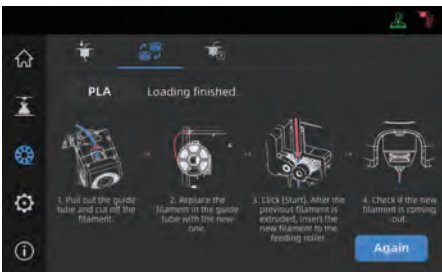
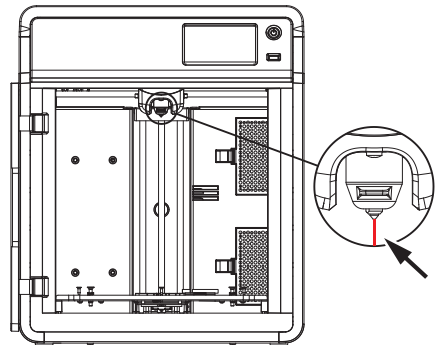
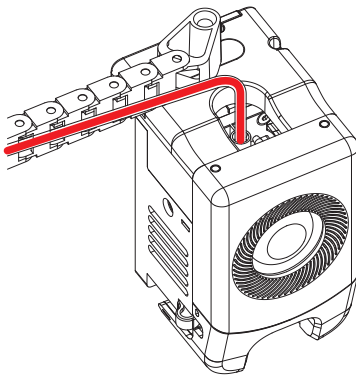
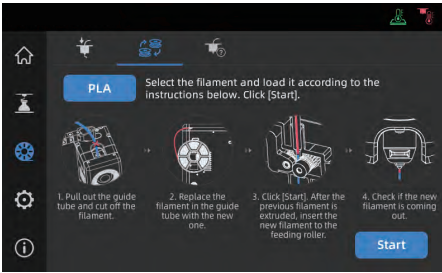

! Note

1. If the previous filament roll is completely used up and there is no filament in the guide tube, you can proceed with the loading process directly.
2. When changing filament, try to clear out the old filament using the new filament.
3. You can click [?] to view the nozzle usage guide on the screen.

4.2 Network Connection

Click  -  to enter the network connection interface.

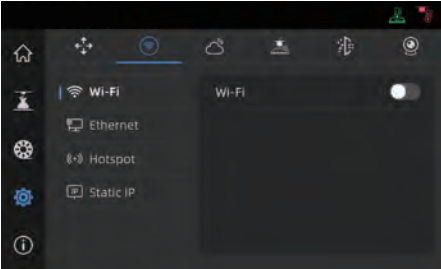

4.2.1 Wireless Network Connection

Turn on the Wi-Fi switch, and tap to connect to the corresponding wireless network.

Once connected successfully, the network will be marked, and an  icon will appear at the top right corner of the screen.

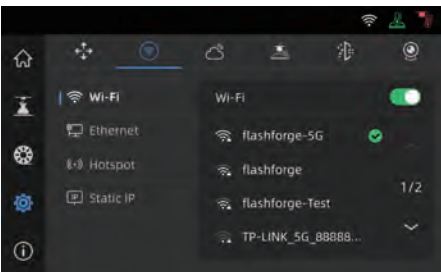
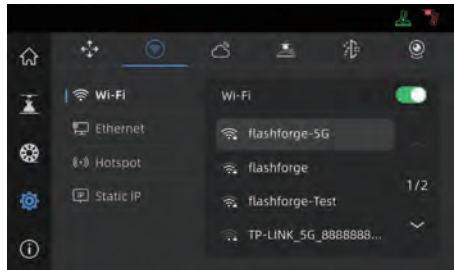

4.2.2 Wired Network Connection

1. Select [Ethernet] and plug the network cable into the Ethernet port on the back of the printer following on-screen instructions.
2. Once connected successfully, it will display as [Connected], and an  icon will appear at the top right corner of the screen.

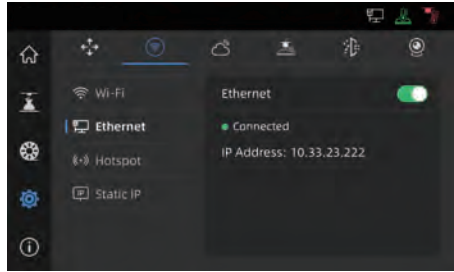
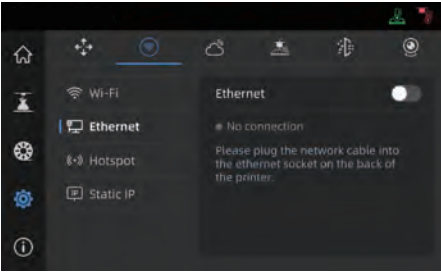

4.3 Printing Methods

4.3.1 Printing via USB

The printer supports printing via USB. Save the sliced file to a USB flash drive, insert it into the printer, and select the corresponding file to start printing.

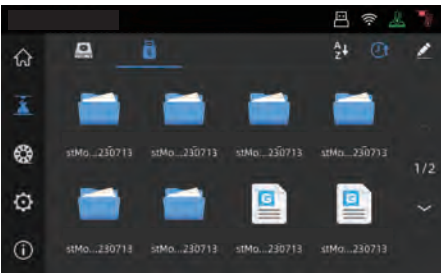

4.3.2 Printing via Wi-Fi transfer



After successfully connecting the printer to the network, open Ania 3D Slicer. After finishing slicing, click [Print] in the menu and select the Ania QD330 as the machine to connect to. You can connect it to the printer by entering the IP address or by automatic scanning.



Note

The printer and the computer must be connected to the same network.



The IP address can be viewed by long-pressing the connected network or in the Printer Info interface by clicking  - 

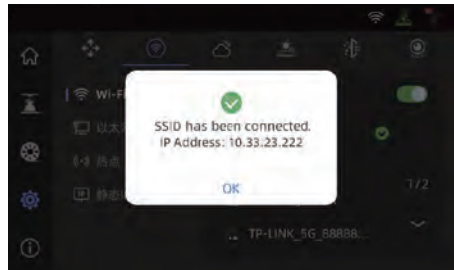
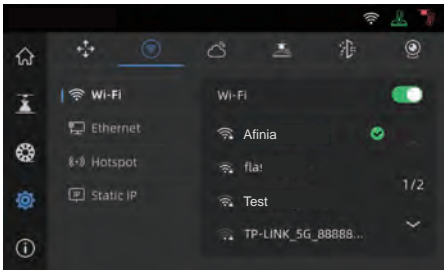

4.3.3 Printing via Cloud

Printing via FlashCloud

1. Click  - , turn on the FlashCloud switch, and view the registration code.

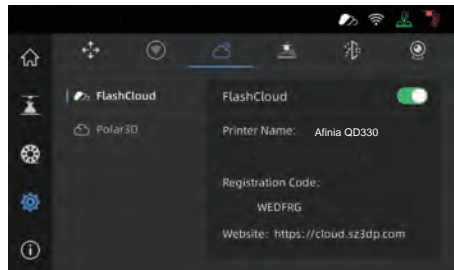

2. Open the FlashCloud website and register an account. After email activation, you can log in and use. FlashCloud: <https://cloud.sz3dp.com/>
3. Click [My Printer] - [Add Printer]. On the Add Printer page, enter the registration code (cloud registration code) and name the printer. After clicking [OK], the information will appear on the printer's FlashCloud interface.

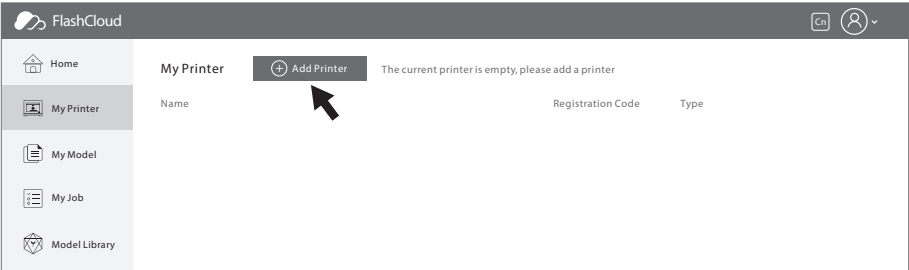

Printing via Polar Cloud

Open the Polar Cloud website and register an account.
 Polar Cloud: <https://polar3d.com>

Note: Polar Cloud service may not be available outside the United States.

After logging in, click the icon at the top right corner, click [Settings], and click [PIN Code] in the menu to find the PIN code.

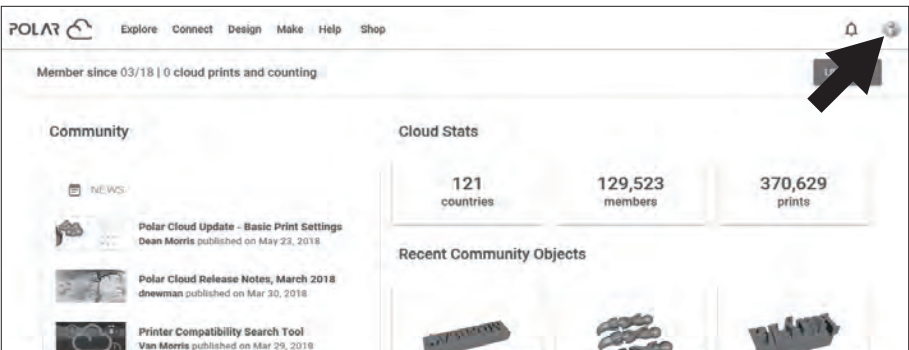

After connecting the Ania QD330 to the network, simply turn on the Polar Cloud switch and enter your account and PIN code.

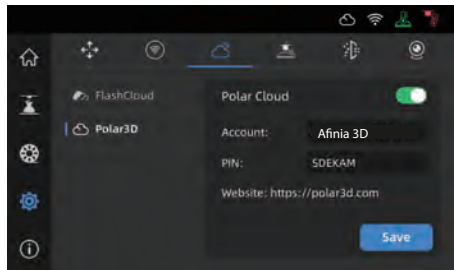

4.4 Camera Connection

1. Click   to turn on the camera switch.

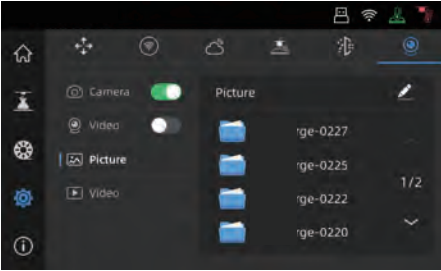

2. After the printer is connected to Afinia 3D Slicer you can view real-time images via Afinia 3D Slicer. [Multi-Machine Control].



3. Turn on the video switch, and video files will be generated after the model is printed. You can export them to a USB flash drive for viewing.

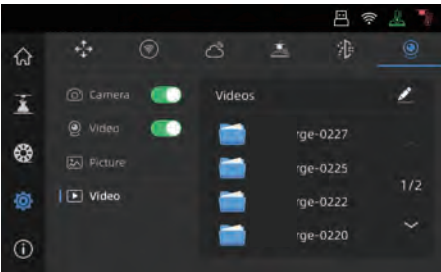

4.5 Model Removal After Printing

Note When printing is completed, the nozzle and build plate may still be at a high temperature. It is recommended to allow them to cool down before removing the model.

After printing is completed, directly take out the flexible steel plate and bend the platform to remove the model. Ensure there is no residual filament on the platform before the next print.

Tips on Model Removal:

1. Please take the platform plate outside the printer for model removal to prevent model debris from accumulating inside the printer. It's recommended to keep the chamber clean.
2. For models printed with TPU or other flexible materials, it is recommended to use a scraper for removal, which ensures you can remove the flexible model from the bed without causing damage.

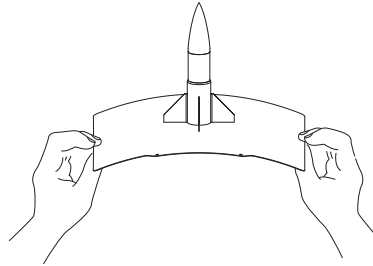
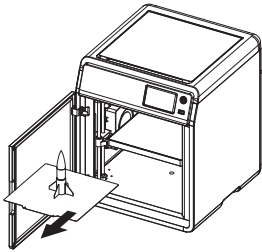

5. Introduction to Auxiliary Functions

Note The interface layout may change whenever there is an upgrade of firmware.

5.1 Leveling and Calibration

During the first startup, equipment calibration will be performed. During subsequent use, choose leveling or vibration compensation as needed.



When to perform leveling:

- ◆ If continuously printing with PLA material, perform automatic leveling once with no need to do so before each print. However, performing leveling can inevitably improve the printing success rate;
- ◆ When switching between different materials (e.g., from PLA to ABS), please perform leveling before each print;
- ◆ If the platform-nozzle distance is too far (poor adhesion) or too close (no filament extrusion), please perform automatic leveling;
- ◆ After replacing the build plate or nozzle, please perform automatic leveling.

When to perform vibration compensation:

- ◆ When there is noticeable ghosting and ringing on 3D prints;
- ◆ After adjusting the tension of the synchronous belt;
- ◆ When the printer has been unused for a long time and is now being restarted.

Instructions:

Click  -  to enter the leveling and calibration interface. Choose [Leveling] or [Vibration test], click [Start], and the printer will automatically perform the corresponding operation. (Note: Before calibration, ensure there are no foreign objects on the platform or at the nozzle tip.)

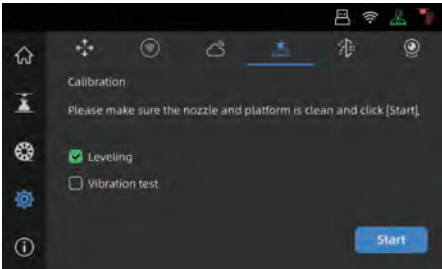

5.2 Air Filtration

The printer has internal&external circulation air filtration mechanisms for different materials.

During printing, the printer can automatically choose between internal circulation filtration or external filtration based on the detected printing material. (Note: Files exported from third-party slicing software cannot be automatically recognized and require manual selection.)

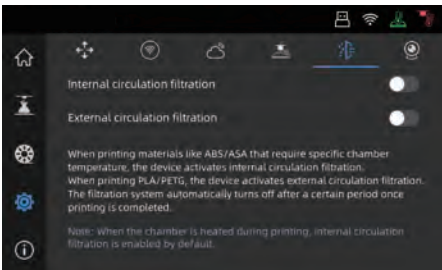

5.3 Other Function Settings

In the information interface, you can enable or disable sound, filament detection and auto shutdown, and perform firmware updates.

- ◆ When [Filament detect] is enabled, the printer will stop printing if filament runs out mid-print.
- ◆ When [Auto shut down] is enabled, the printer will power off automatically 30 minutes after completing a print job.
- ◆ When connected to a wireless network, click [Firmware update] to view the current version, check for updates, and perform online firmware updates.

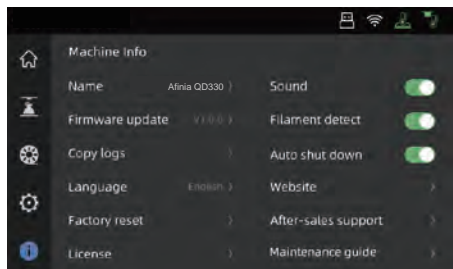

6. Maintenance

6.1 Suggestions on Platform Plate Usage

1. Powder coated PEI plate requires glue and is suitable for printing PLA/PETG/PLA-CF/PETG-CF/ABS/ASA. TPU printing does not require glue. This plate comes with the printer.
2. PEI film plate is suitable for printing PLA/TPU without glue. For PETG, it's recommended to use glue. This plate can be purchased separately.
3. PC sticker platform plate is suitable for printing PC/ABS/ASA. This plate can be purchased separately.
4. After applying glue to the platform plate, it can be cleaned with water.
5. If the platform plate gets oily, it can be cleaned with a dish detergent.
6. If the platform plate deforms significantly after long-term use, it's recommended to replace it with a new one.

6.2 Suggestions on Nozzle Usage

1. Please use one nozzle for the same type of material to avoid clogs and extend nozzle lifespan, especially when working with fiber-reinforced materials and PETG. Please avoid mixing them with other materials.
2. When switching to a different material with the same nozzle, if the new material's printing temperature is lower, adjust the setting to a higher temperature for filament extrusion to purge old filament from the nozzle.
3. When switching to a different material with a higher printing temperature, just load the new filament.
4. To clean residual filament inside the nozzle, you can perform multiple filament loading or manually clear any remaining filament using the unclogging pin tool.
5. After replacing the nozzle, please perform leveling again.

6.3 General Maintenance

1. Please apply lubricating oil to the guide rails after 200 hours of printing.
2. Please replace the filter cotton every 300 hours of printing or when it appears darker in color.
3. Please clean the filament residue inside the equipment chamber in time.

7. Q&A

Q1. How to unclog the nozzle?

Method 1: Click [Load] and heat the nozzle to the printing temperature of the used filament. After heating, remove the filament guide tube, and check if the filament is bent or filament tip is not smooth. If so, trim and insert the guide tube and filament into the nozzle, then click [Load] and check.

Method 2: If Method 1 doesn't work, use the unclogging pin tool.

Method 3: If Method 2 doesn't work, please replace the nozzle.

Q2. How to replace the nozzle?

Note Please power off the printer before replacing the nozzle!

1. Remove the filament guide tube and cut the filament.

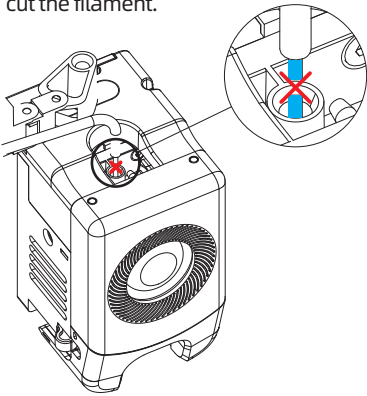

2. Press the left and right buckles and remove the nozzle. Trim the filament along the nozzle top.

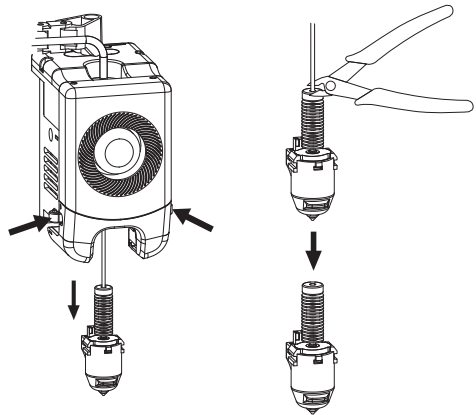

3. Insert the new nozzle into the extruder and you can hear a "click" sound indicating the buckle position has changed. Ensure that the nozzle slot aligns flush with the bottom of the extruder. Note: If you have trouble aligning the nozzle, you can press the buckles during installation or remove the front cover of the extruder (grab the lower part of the front cover with your hand and lift it upward slightly) to check the position.

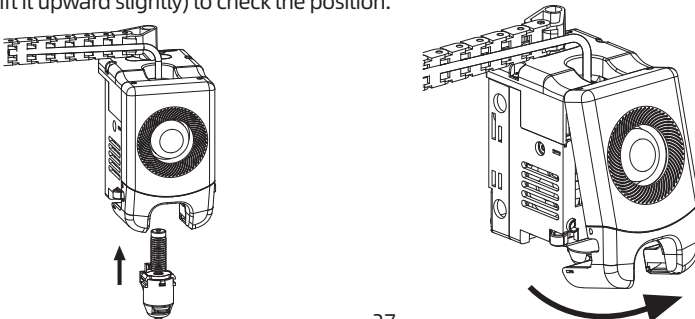

Whether it is installed in place is judged as follows:

1. Ensure the nozzle is pressed to the bottom firmly during installation.
2. Check if it is properly installed:

a. Check the red buckle positions on the left and right.

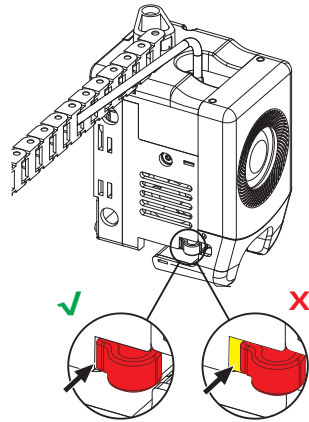

b. Check if the nozzle slot is flush with the bottom of the extruder (if your view is obstructed, you can remove the front cover of the extruder to observe).

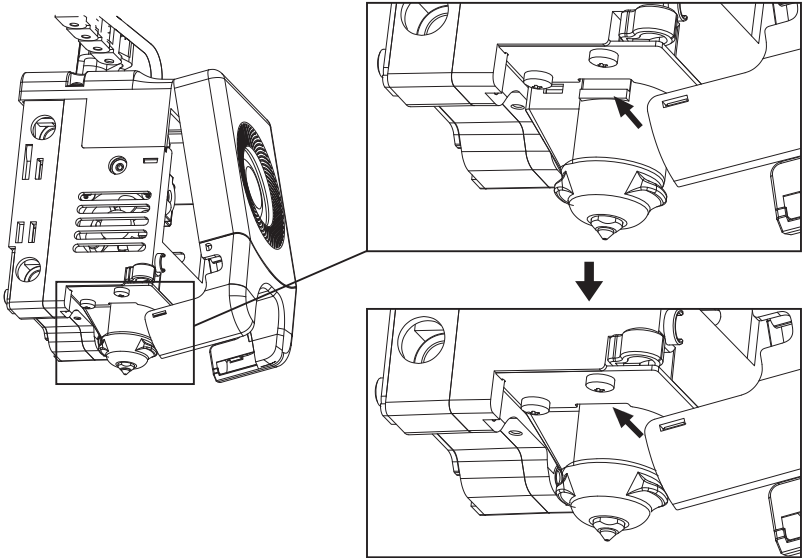

4. Power up the printer, click [] to enter the loading interface, and follow the on-screen instructions to complete filament loading (refer to 4.1.1). Filament coming out of the new nozzle smoothly indicates a successful nozzle replacement.

Q3. Is leveling required after nozzle replacement?

Yes. It is recommended to perform automatic leveling to ensure high print quality as slight errors may occur during nozzle installation. The equipment defaults to the leveling operation before each print.

Q4. What to do if the extruder moves but doesn't extrude filament at the beginning of printing after clicking the model for printing?

1. Observe the filament guide tube to check if filament has entered the nozzle. If not, please click [Load] until filament comes out.
2. Check if the nozzle is clogged. If so, please refer to the solution of Q1.

Q5. What to do if the nozzle position is too high (far from the platform) or too low (hitting the platform) during printing? How to level it?

Please check if the platform is properly installed and there is no excessive residue on the nozzle. If these issues exist, address them first. Then, go to the settings interface, select the leveling option, and perform automatic leveling or enable automatic leveling before printing.

Q6. Can filaments from other brands be used?

Yes. You can use filaments from other brands, but certain parameter adjustments are required due to slight temperature differences in different filaments.

Q7. Is it safe to print with ABS material?

ABS can release toxic gases during heating. It is recommended to enable internal-circulation air filtration during or after printing. If conditions permit, consider printing in a well-ventilated area. It is recommended to print non-toxic materials such as PLA in children's activity places.

Q8. What to do if the printed model warps or doesn't adhere well?

Method 1: Increasing the platform temperature can improve the adhesion between the platform and the model.

Method 2: Adding a brim during model slicing can alleviate the issue.

Method 3: Apply glue.

Method 4: Clean the platform to remove any oil or dirt.

Method 5: Check if the platform is level. The leveling and calibration function can be used.

Q9. What to do if print files can not be found and the screen displays only folders after inserting the USB flash drive?

The USB flash drive format is incorrect. The printer supports the FAT32 file system. Please format the USB flash drive to FAT32.

Q10. What to do with the Wi-Fi connection failure?

1. Please check if the Wi-Fi name contains special characters. If so, modify it and try again.
2. Please check if the password contains special characters. If so, modify it and try again.

Q11. Firmware update precaution.

Do not power off the printer or disconnect from the network during firmware download or update to prevent update failures.

Q12. Why is the boot screen white?

If the startup sound can be heard, please replace the screen or cable. If not, please contact our after-sales personnel.

8. Help and Support

If the issues or questions are not covered in this User Guide, you can seek for solutions on our official web site or contact us by phone.

There are instructions and solutions to common issues that can be found on our official web site. Many questions are answered at Afinia's official website www.afinia.com/support.

Afinia's service team can be reached by phone from 8:00 AM to 5:00 PM, from Monday to Friday. In case you contact us during off-duty time, your inquiry will be answered the next working day immediately.

Note

Changing different filaments may leave minor impurities in the nozzle, leading to clogs. As this can be solved by just unclogging it, it's not owing to a quality issue. If you encounter this problem during use, please contact customer support and follow their guidance for unclogging.

Support Phone: 952-279-2643

E-mail: support@afinia.com