

Distributed by



MG400

Lightweight desktop robot,
smaller footprint than A4 paper!

MG400 is a lightweight desktop robot with a footprint smaller than one piece of A4 paper. Designed to be flexible to deploy, easy to use, and safe to collaborate, Magician Pro makes automation affordable and accessible for diversified and small-batch production scenarios. Featuring 750g payload, 440mm maximum reach, hand-held teaching and collision detection, Magician Pro truly fits perfectly for lightweight desktop applications and fast deployment in the production line.



Specifications

Product Name	DOBOT MG400	
Product Name	DT-MG-P4R07-01I	
Degree of Freedom	4	
Payload	500g (Max 750g)	
Reach	440mm	
Repeatability	±0.05mm	
Joint Ranges	J1	±160°
	J2	-25° ~ 85°
	J3	-25° ~ 105°
	J4	-180° ~ 180°
Joint Maximum Speed	J1	300° /s
	J2	300° /s
	J3	300° /s
	J4	300° /s
Power	100~240V AC, 50/60 Hz	
Nominal Voltage	48V	
Nominal Power	240W	
Communication Interface	TCP/IP, Modbus TCP	
Installation Way	Counter	
Weight	8kg	
Base Size	190mm × 190mm	
Working Environment	0 °C ~40 °C	
Software	DobotStudio 2020, SCStudio	

Small Space Occupation

MG400 adopts a compact design that integrates the controller into the machine body with a 190mm*190mm footprint, which can be easily integrated into any production environment. Any space that is smaller than one piece of A4 paper, MG400 is good to go.



Professional Performance

MG400 is equipped with servo motors with a high-precision absolute encoder, a self-developed servo drive and controller, achieving a repeatability of ±0.05mm.

With the vibration suppression algorithm deployed in the controller level, under the condition of ensuring the space trajectory accuracy of the robot's multi-axis motion, the repeatability bandwidth stabilization time is accelerated by 60%, and the residual vibration is reduced by 70%.

Simplicity Means Productivity

The design concept of simplicity is integrated into every dimension of the robot, making it much easier for small and medium-sized enterprises to apply automation.

Shorter deployment time: integrated & compact design, flexible & easy to deploy, plug and work.

More programming options: offering trajectory reproduction, graphical programming, and Lua script programming, which are ideal for applications of different complexity and developers with different programming skills.

Higher programming efficiency: Intuitive programming interface and guided-interactive design greatly improve the programming efficiency and lower the threshold of robot applications.

Higher debugging efficiency: supported by the robot dynamic gravity compensation algorithm, Magician Pro's hand-held teaching is smooth, easy and efficient, reducing the teaching time during robot programming up to 80%.

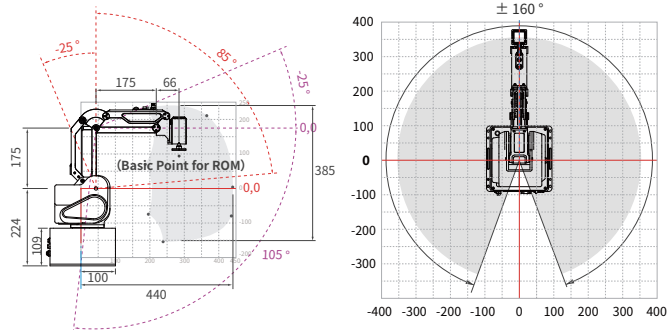



DOBOT MG400

Shenzhen Yuejiang Technology Co.,Ltd | China

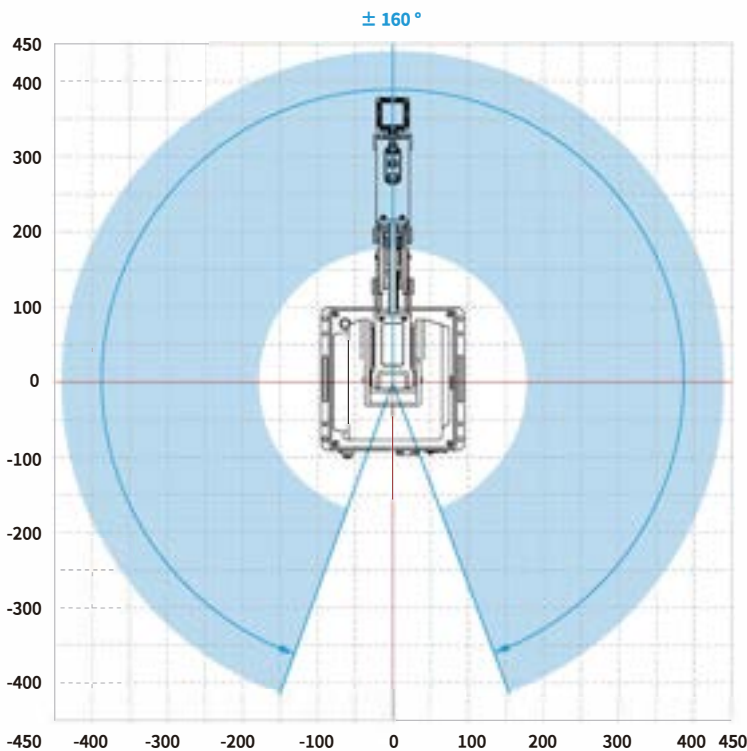
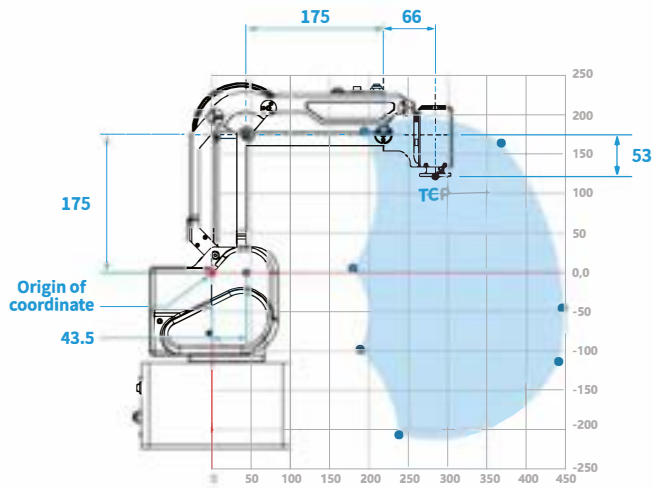

Product Name DOBOT MG400
Product Model DT-MG400-4R075-01

Controlled Axes 4
Rated Load 500 g (Max. 750 g)
Max. Reach 440 mm
Repeatability ± 0.05 mm

Motion Parameters	Joint	Motion Range	Max. Speed
	J1	$\pm 160^\circ$	300 %/s
	J2	$-25^\circ \sim 85^\circ$	300 %/s
	J3	$-25^\circ \sim 105^\circ$	300 %/s
	J4	$-360^\circ \sim 360^\circ$	300 %/s

Power Input 100~240 V AC, 50/60 Hz
Rated Voltage DC 48 V
Rated Power 150 W
Communication TCP/IP, Modbus TCP
Installation Desktop
Weight 8 kg
Base Dimension 190 mm \times 190 mm
Work environment $0^\circ\text{C} \sim 40^\circ\text{C}$
Software DobotStudio Pro, SCStudio

Interface

Base: Digital Input 16
 Digital Output 16
 Ethernet 2
 USB 2.0 2
 Encoder Input 1
 Air way 1

End: Digital Input 2
 Digital Output 2
 Air way 1



Mounting Drawing

