

# VENOM X18R 200CC AUTOMATIC PARTS CATALOG



## INTRODUCTION

When placing orders for parts, use this booklet as a reference. Refer to the illustrations for the name, item code, or fitment details by examining the size and appearance. Locate the corresponding number in the illustration to identify the name, item code, and quantity. Please note that changes to the information in this booklet may occur without prior notice.

## 发动机 Engine

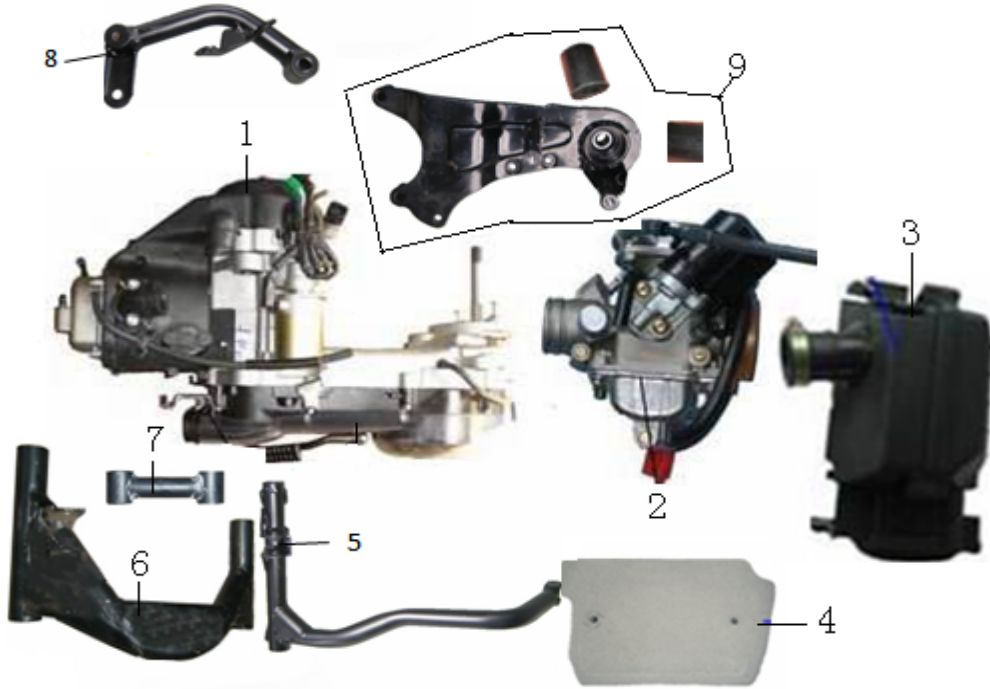

序 NO	件 号 Code name	中文名称 Chinese	英文名称 Description	数量 Q'ty	单价	
					¥	\$
1	01010045	发动机(8极交流)	Engine	1		
2	01030013	化油器部件 (170-C)	Carburettor assy	1		
3	01040012	空滤器	Air Filter	1		
4	190098	滤芯	Filter Foam	1		
5	02011141	后平叉左	Rear Fork (Left)	1		
6	02011144	吊架	Engine Hanger	1		
7	02011146	吊架拉杆	Hanger Connection	1		
8	02011142	后平叉右	Rear Forl (right)	1		
9	02011147	动力连接板	Engine Juction Plate	1		

### 曲轴箱总成（一） Crankcase 1

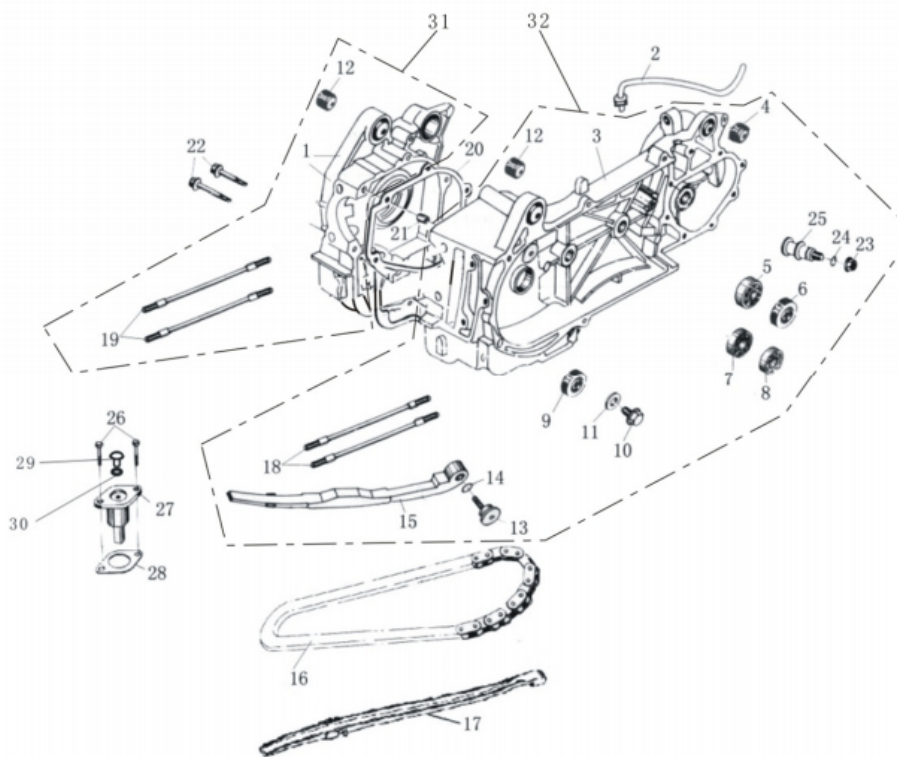

序 NO	件 号 Code name	中文名称 Chinese	英文名称 Description	数量 Q'ty	单价	
					¥	\$
1	2.20.05.67.02000	右箱体	R.Crankcase Assembly	1		
2	1.20.04.01.12000	通气管组合	Breather Pipe Assembly	1		
3	2.20.04.67.07000	左箱体本体总成	L.Crankcase Assembly	1		
4	1.20.04.01.08000	后减震套	Rear Shock Absorber Sheath	1		
5	1.00.01.6004-2RS	轴承6004-2RS	Bearing6004-2RS	1		
6	1.20.04.01.10000	输出轴油封27×42×7	Oil Seal of Output Shaft	1		
7	1.00.01.6301	轴承6301	Bearing6301	1		
8	1.00.01.6002	轴承6002	Bearing6002	1		
9	1.20.04.01.13000	曲轴油封19.8×30×5	Oil Seal 19.8×30×5	1		
10	1.20.04.01.14000	放油螺栓M12×1.5×14	Bolt M12×1.5×14	1		
11	1.20.04.01.03000	平垫 12×18×1	Gasket 12×18×1	1		
12	1.20.04.01.09000	前减震套	Front Shock Absorber Sheath	2		
13	1.20.13.01.01000	固定拉力杆螺钉	Screw	1		
14	1.20.13.01.02000	O形圈16×1.5	O-Ring 16×1.5	1		
15	1.20.13.01.05000	拉力杆	Tension Rod	1		
16	1.20.13.32.04000	正时链条	Timing Chain	1		
17	1.20.13.01.06000	分气链条导件	Chain Guide	1		
18	1.20.04.06.04000	双头螺柱M8×209	Stud Bolt M8×209	2		

19	1.20.05.06.01000	双头螺柱M8×201	Stud Bolt M8×201	2		
20	1.20.04.01.05000	右箱体垫	Gasket	1		
21	1.20.04.01.01000	定位套 ø8×14	Locating Bush ø8×14	2		
22	1.05.01.09.0650	螺栓M6×50	Bolt M6×50	2		
23	1.05.04.01.0800	螺母SM8	Nut M8	1		
24	1.20.04.01.11000	O形圈7.5×1.5	O-Ring 7.5×1.5	1		
25	1.20.04.03.02000	刹车销	Brake Pin	1		

曲轴箱总成 (二)

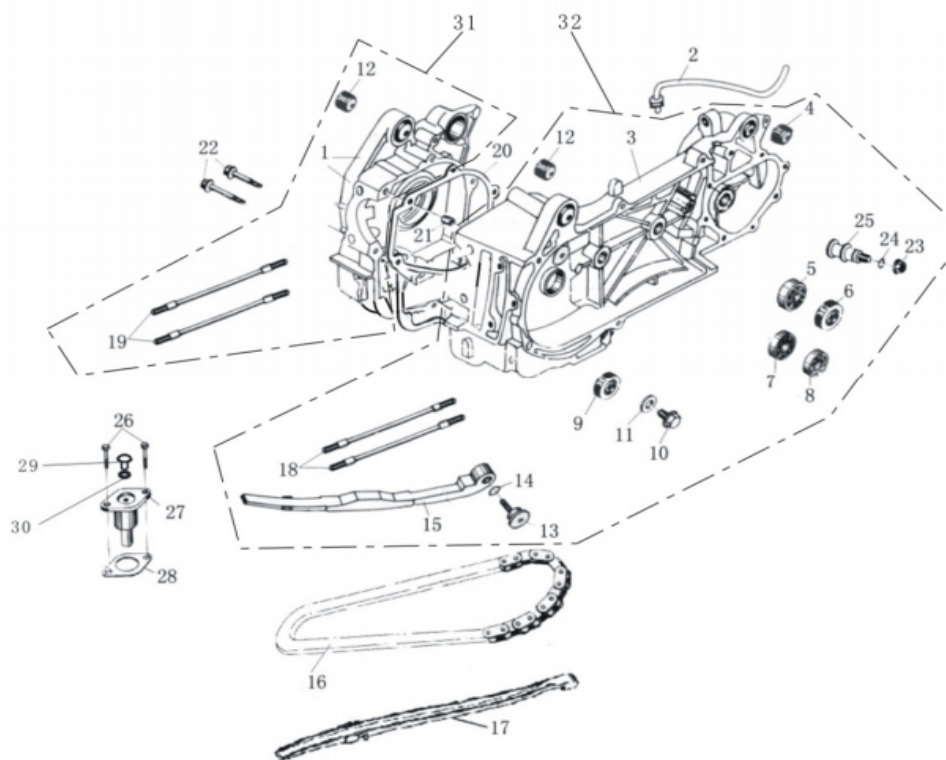

序	件号	中文名称	英文名称	数量	单价	
NO	Code name	Chinese	Description	Q'ty	¥	\$
26	1.05.01.09.0622	螺栓M6×22	Botl M6×22	2		
27	1.20.13.01.07000	压链器	Chain Adjuster	1		
28	1.20.13.01.03000	纸垫	Gasket	1		
29	1.20.13.01.08000	扁头螺钉	Screw	1		
30	1.20.13.01.09000	O形圈9.5*1.5	O-Ring 9.5*1.5	1		
31	2.20.05.67.99000	右箱体总成	R.Crankcase Assembly	1		
32	2.20.04.67.99000	左箱体总成	L.Crankcase Assembly	1		

变速箱盖总成

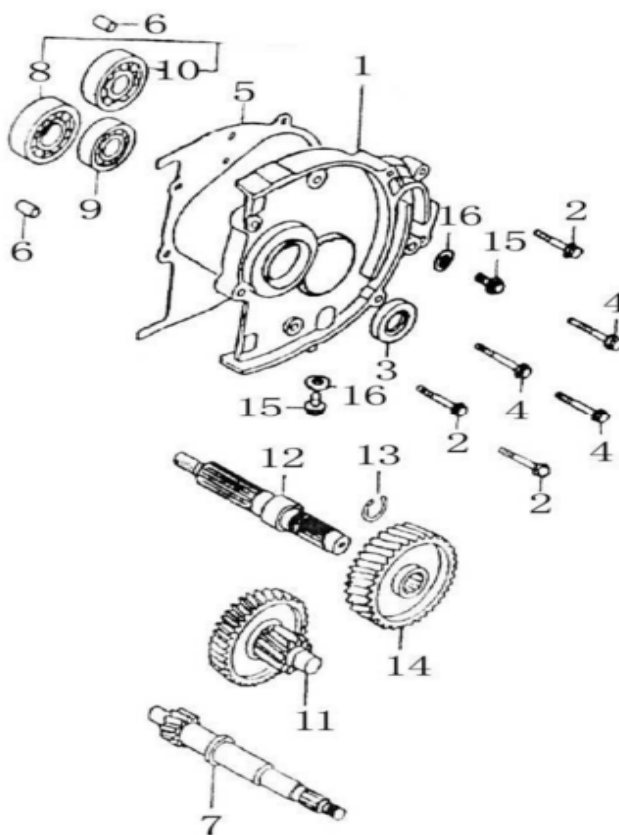

序	件号	中文名称	英文名称	数量	单价	
NO	Code name	Chinese	Description	Q'ty	¥	\$
1	2.20.20.01.01000	变速箱盖	Gearcase Cover	1		
2	1.05.01.09.0628	螺栓M6×28	Bolt M6×28	3		
3	1.20.20.01.08000	输入轴油封20×32×6	Oil Seal 20×32×6	1		
4	1.05.01.09.0635	螺栓M6×35	Bolt M6×35s	3		
5	1.20.20.01.06000	变速箱盖垫片	Gearcase Gasket	1		
6	1.20.04.01.01000	定位套 ø8×14	Locating Bush ø8×14	2		
7	1.20.20.08.02000	输入轴	Input Shaft	1		
8	1.00.01.6204	轴承6204	Bearing 6204	1		
9	1.00.01.6202	轴承6202	Bearing 6202	1		
10	1.00.01.6203	轴承6203	Bearing 6203	1		
11	1.20.20.08.09000	中间齿轮轴组	Intermediate Gear Shaft	1		
12	1.20.20.01.05000	变速箱输出轴	Input Shaft	1		
13	1.05.06.02.2000	轴用挡圈20	Check Ring 20	1		

14	1.20.20.01.03000	输出齿轮	Output Gear	1		
15	1.05.01.09.0812	螺栓M8×12	Bolt M8×12	2		
16	1.20.20.01.07000	垫片	Gasket	2		

左盖总成

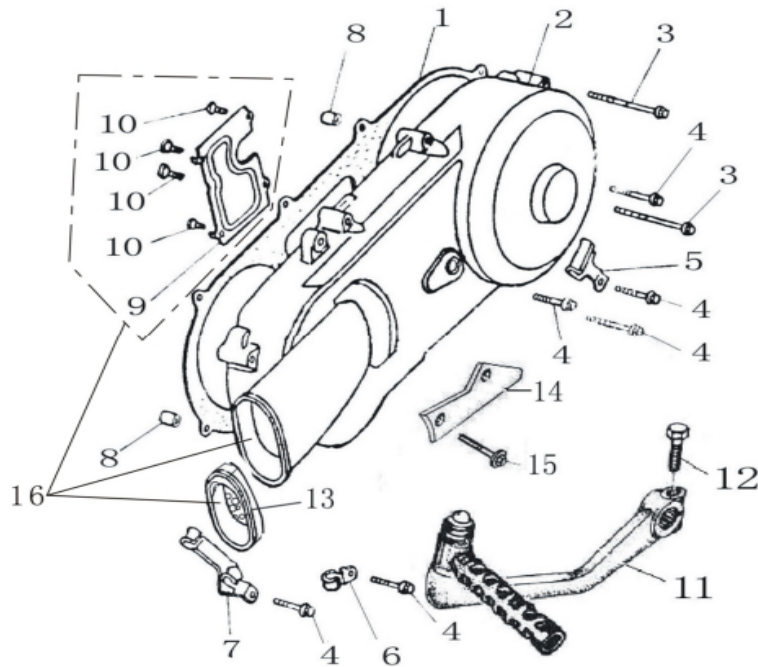

序	件号	中文名称	英文名称	数量	单价	
NO	Code name	Chinese	Description	Q'ty	¥	\$
	1.20.06.03.07000	左盖垫	Left Cover Gasket	1		
2	2.20.06.03.01000	左盖	Left Cover	1		
3	1.05.01.09.0665	螺栓M6×65	Bolt M6×65	2		
4	1.05.01.09.0640	螺栓M6×40	Bolt M6×40	6		
5	1.20.06.01.06000	刹车导线夹	Brake Retainer Grip	1		
6	1.20.06.01.04000	溢流管夹	Tubing Clamp	1		
7	1.20.06.01.05000	油门拉筋固定架	Accelerator Fixed Bracket	1		
8	1.20.04.01.01000	定位套 ø8×14	Locating Bush ø8×14	2		
9	1.20.06.01.03000	通气导板	Breather Guide Plate	1		
10	1.05.02.03.4208	自攻螺钉ST4.2×8	Tapping Screw ST4.2×8	4		
11	1.20.17.01.05000	起动杆总成	Starting Lever Assembly	1		
12	1.05.01.08.0622	螺栓M6×22	Bolt M6×22	1		



13	1.20.06.01.10000	吸风管	Aspiration Pipe	1		
14	1.20.06.01.08000	固定架	Fixed Bracket	1		
15	1.05.01.09.0612	螺栓M6×12	Bolt M6×12	1		
16	2.20.06.03.99000	左盖总成	Left Cover Assembly	1		

右箱体端盖总成

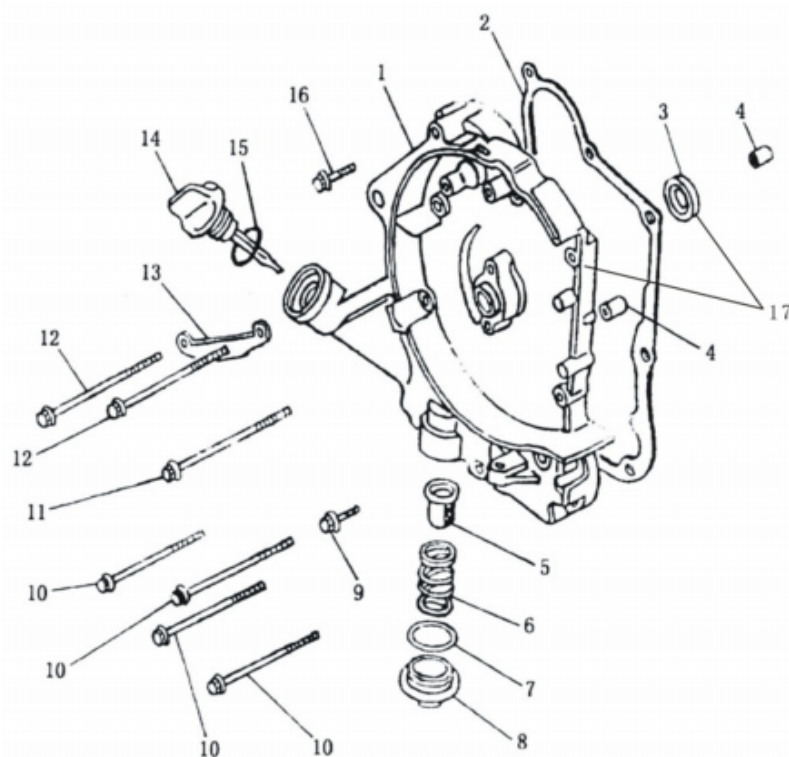

序	件号	中文名称	英文名称	数量	单价	
NO	Code name	Chinese	Description	Q'ty	¥	\$
1	2.20.07.01.01000	右盖	Right Cover	1		
2	1.20.07.01.06000	右盖垫	Right Cover Gasket	1		
3	1.20.04.01.13000	曲轴油封19.8×30×5	Oil Seal 19.8×30×5	1		
4	1.20.04.01.01000	定位套φ8×14	Locating Bush φ8×14	2		
5	1.20.07.01.09000	滤油网	Oil-Filter Screen	1		
6	1.20.07.01.03000	滤油网弹簧	Oil-Filter Screen Spring	1		
7	1.20.07.01.04000	O形圈30.5×3	O-Ring 30.5×3	1		
8	1.20.07.01.02000	滤油网螺帽	Oil-Filter Screen Nut	1		
9	1.05.01.09.0632	螺栓M6×32	Bolt M6×32	1		

10	1.05.01.09.0695	螺栓M6×95	Bolt M6×95	4	
11	1.05.01.09.06100	螺栓M6×100	Bolt M6×100	1	
12	1.05.01.09.06110	螺栓M6×110	Bolt M6×110	2	
13	1.20.07.01.08000	触发线卡	Trigger Line Card	1	
14	1.20.07.01.05000	机油尺	Oil Level Gauge	1	
15	1.20.07.01.07000	O形圈18×3	O-Ring 18×3	1	
16	1.05.01.09.0635	螺栓M6×35	Bolt M6×35	1	
17	2.20.07.01.99000	右盖总成	Right Cover Assy	1	

气缸体总成

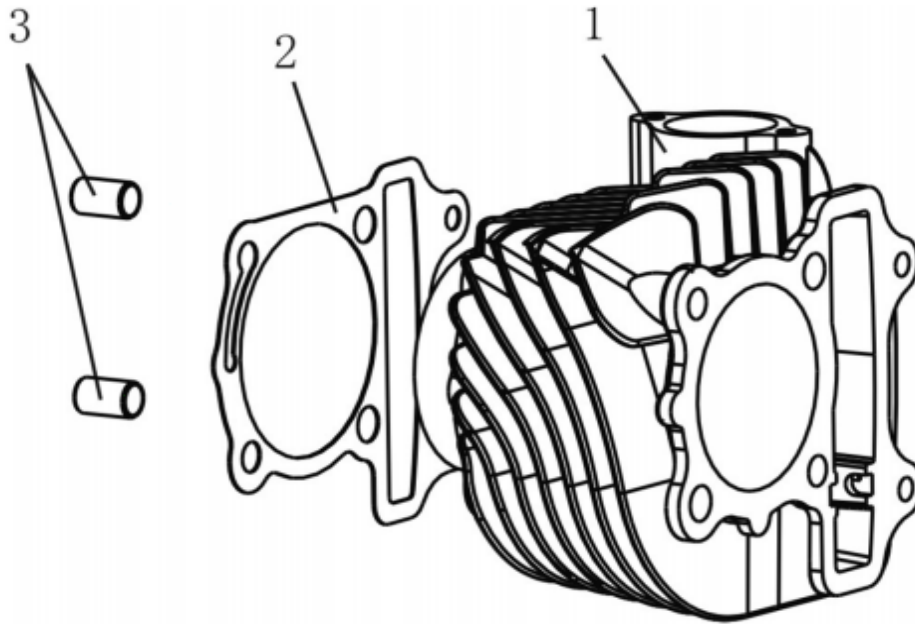

序	件号	中文名称	英文名称	数量	单价	
NO	Code name	Chinese	Description	Q'ty	¥	\$
1	1.20.02.09.03000	气缸体	Cylinder Block	1		
2	1.20.02.09.01000	气缸垫	Cylinder Block Gasket	1		
3	1.20.01.01.01000	定位套φ10×16	Locating Bushφ10×16	2		



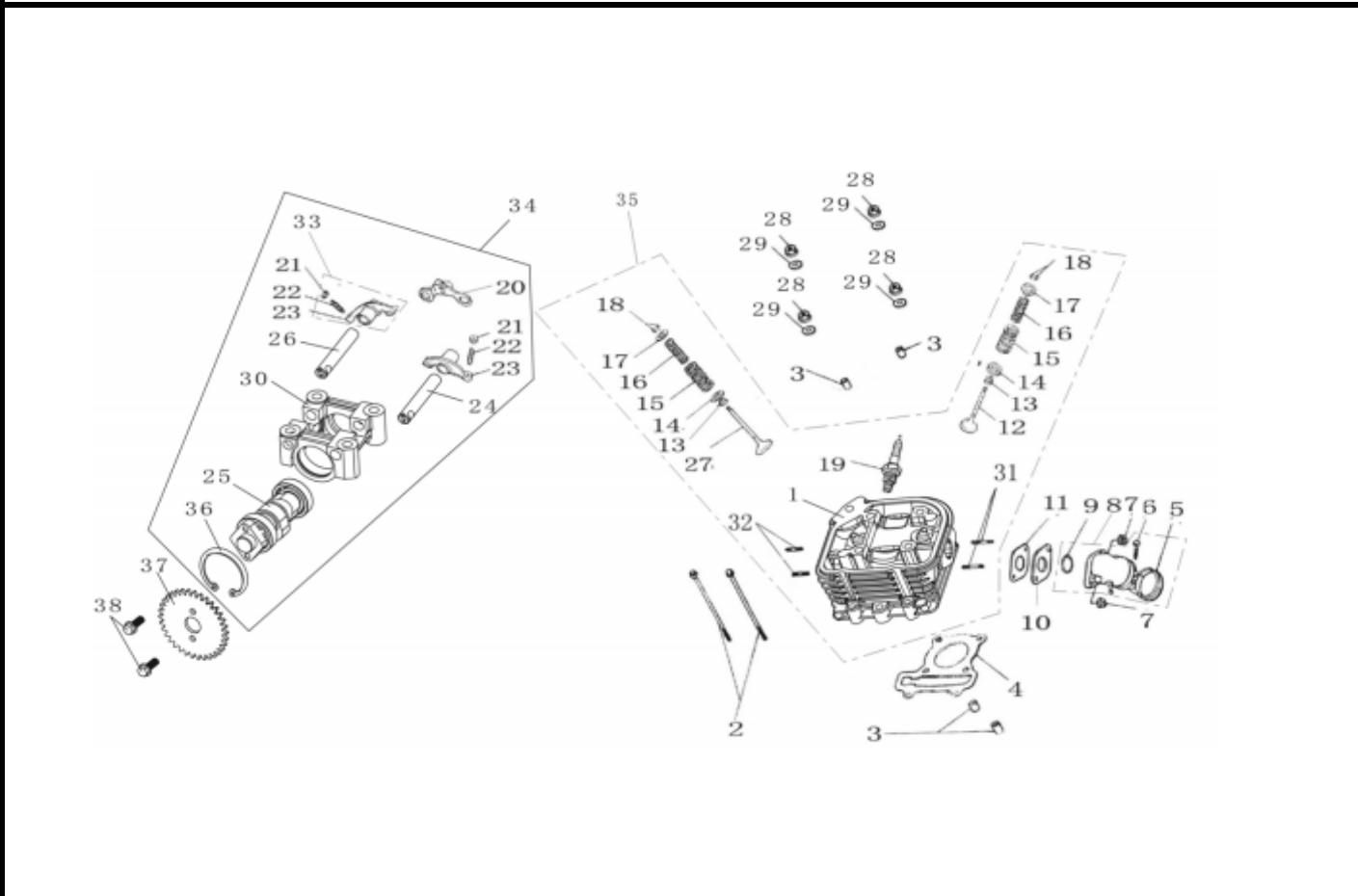

气缸头总成（一）



序	件号	中文名称	英文名称	数量	单价	
NO	Code name	Chinese	Description	Q'ty	¥	\$
1	2.20.01.67.13001	气缸头组（补气状态）	Cylinder Head	1		
2	1.05.01.09.06100	螺栓M6×100	Bolt M6×100	2		
3	1.20.01.01.01000	定位套φ10×16	Locating Bush φ10×16	4		
4	1.20.01.09.15000	气缸头垫片	Cylinder Head Gasket	1		
5	1.20.01.01.16010	进气管夹	Pipe Clamp	1		
6	1.05.02.01.0425	螺钉M4×25	Screw M4×25	1		

7	1.05.04.02.0600	螺母M6	Nut M6	2		
8	1.20.01.01.16000	进气管总成	Intake-Tube Assy	1		
9	1.00.14.265180	O形圈26.5×1.8	O-Ring 26.5×1.8	1		
10	1.20.01.01.12000	隔热板	Thermal Baffle	1		
11	1.20.01.01.11000	垫板	Base Plate	1		
12	1.20.01.06.06000	进气门	Inlet Valve	1		
13	1.20.01.01.14000	气门油封	Valve Oil Seal	2		
14	1.20.01.01.10000	垫片	Gasket	2		
15	1.20.01.06.09000	气门外弹簧	Outer Valve Spring	2		
16	1.20.01.06.08000	气门内弹簧	Inner Valve Spring	2		
17	1.20.01.01.05000	气门弹簧座	Valve Spring Retainer	2		
18	1.20.01.01.07000	气门锁块	Valve Cotter	4		
19	1.20.01.01.17000	火花塞	Spark Plug	1		
20	1.20.12.01.05000	止动板组	Stop Plate	1		
21	1.20.12.01.04020	调整螺母	Adjusting Nut	2		
22	1.20.12.01.04030	调整螺丝	Adjusting Screw	2		
23	1.20.12.06.04010	摇臂	Rocker Arm	2		
24	1.20.12.06.03000	进气摇臂轴组	Inlet Rocker Arm Shaft Assy	1		

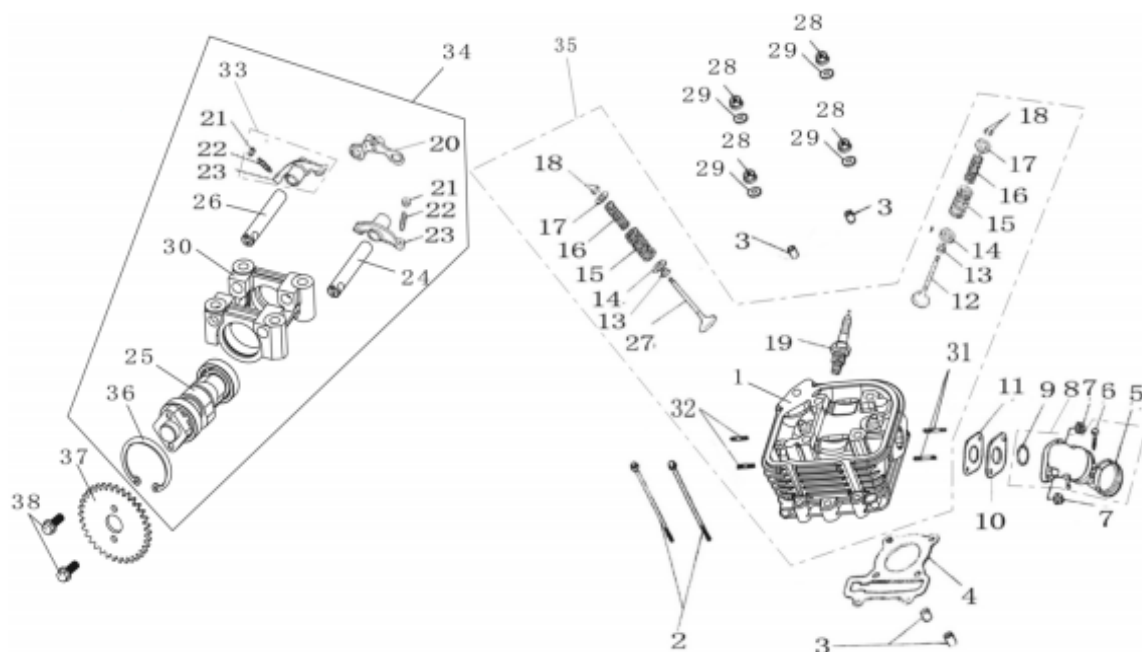
### 气缸头总成 (二)



序	件号	中文名称	英文名称	数量	单价	
NO	Code name	Chinese	Description	Q'ty	¥	\$
25	1.20.11.06.01000	凸轮轴总成	Camshaft Assy	1		
26	1.20.12.06.02000	排气摇臂轴	Inlet Rocker Arm Shaft	1		
27	1.20.01.06.04000	排气门	Exhaust Valve	1		
28	1.05.04.02.0800	螺母M8	Nut M8	4		

29	1.20.04.01.06000	垫圈8	Washer 8	4	
30	2.20.12.06.01000	凸轮轴座	Camshaft Retainer	1	
31	1.20.01.01.03000	双头螺柱M6×63	Stud Bolt M6×63	2	
32	1.20.01.08.02000	双头螺柱M8×32	Stud Bolt M8×32	2	
33	1.20.12.06.04000	气门摇臂	Valve Rocker	2	
34	2.20.12.06.99000	凸轮轴座总成	Camshaft Tetainer Assy	1	
35	2.20.01.67.99001	气缸头总成 (补气状态)	Cylinder Head Assy	1	
36	1.05.06.01.3500	孔用挡圈35	Check Ring	1	
37	1.20.11.32.02000	正时链轮	Timing Sprocket	1	
38	1.05.01.08.0512	螺栓M5×12	Bolt M5×12	2	

气缸盖总成

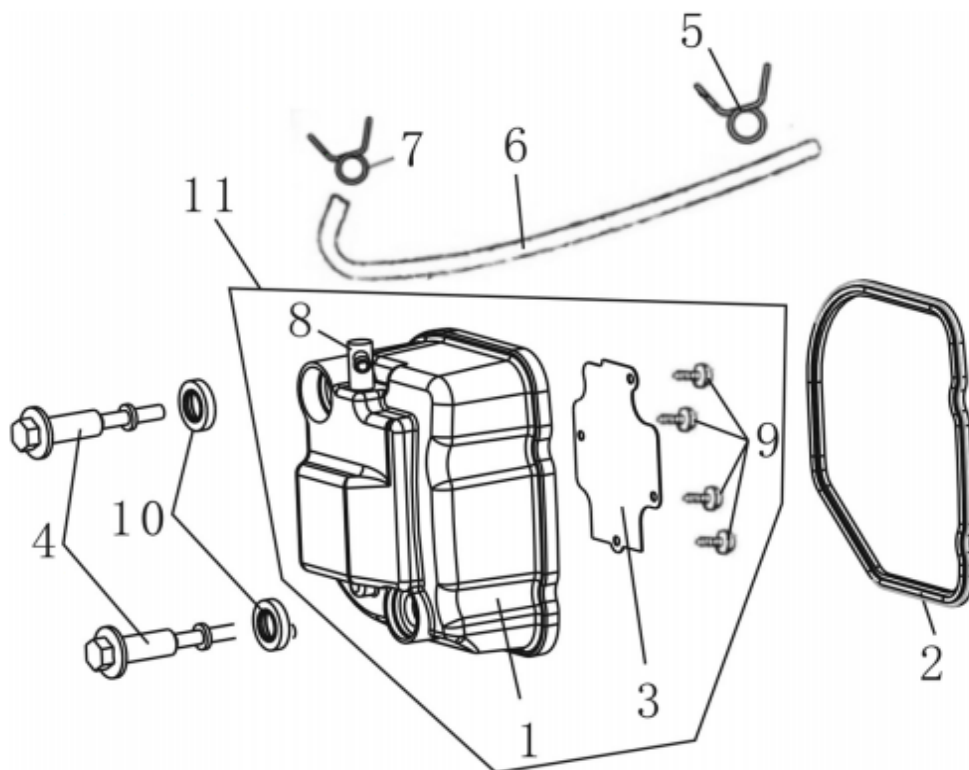

序	件号	中文名称	英文名称	数量	单价	
NO	Code name	Chinese	Description	Q'ty	¥	\$
1	2.20.03.06.01000	气缸头盖	Cylinder Head Cover	1		
2	1.20.03.06.03000	气缸盖密封圈	Seal Ring of Cylinder Head Cover	1		
3	1.20.03.01.02008	盖片	Cover Slip	1		

4	1.20.03.32.30000	盖罩螺栓	Bolt	2	
5	1.20.03.01.05010	管夹	Pipe Clamp	1	
6	1.20.03.01.05000	通气管组	Breather Pipe Assy	1	
7	1.20.03.01.05020	管夹	Pipe Clamp	1	
8	1.20.03.01.04000	管接头组件	Pipe Joint Assy	1	
9	1.05.02.03.4208	自攻螺钉ST4.2×8	Tapping Screw ST4.2×8	4	
10	1.20.03.32.31000	衬胶垫圈	Rubber Gasket	2	
11	2.20.03.06.99000	气缸头盖总成	Cylinder Head Cover Assy	1	

曲轴连杆组件、活塞组件

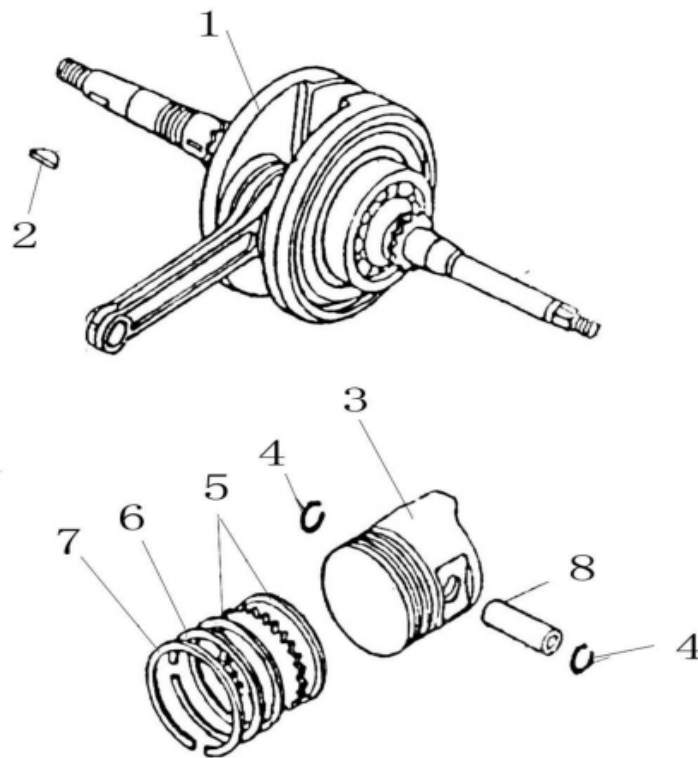

序 NO	件号 Code name	中文名称 Chinese	英文名称 Description	数量 Q'ty	单价 ¥		
							\$
1	1.20.09.08.01000	曲轴连杆总成	Connecting Rod of Crank Shaft	1			

2	1.20.09.01.01010	半圆键	Woodruff Key	1	
3	1.20.10.08.01000	活塞	Piston	1	
4	1.20.10.08.04000	活塞销卡簧	Clamp Spring	2	
5		油环组合(含刮片环)	Oil Ring		
6	1.20.10.08.02000	第二道气环	Piston Ring 1	1	
7		第一道气环	Piston Ring 2		
8	1.20.10.08.03000	活塞销	Piston Pin	1	

电启动部件

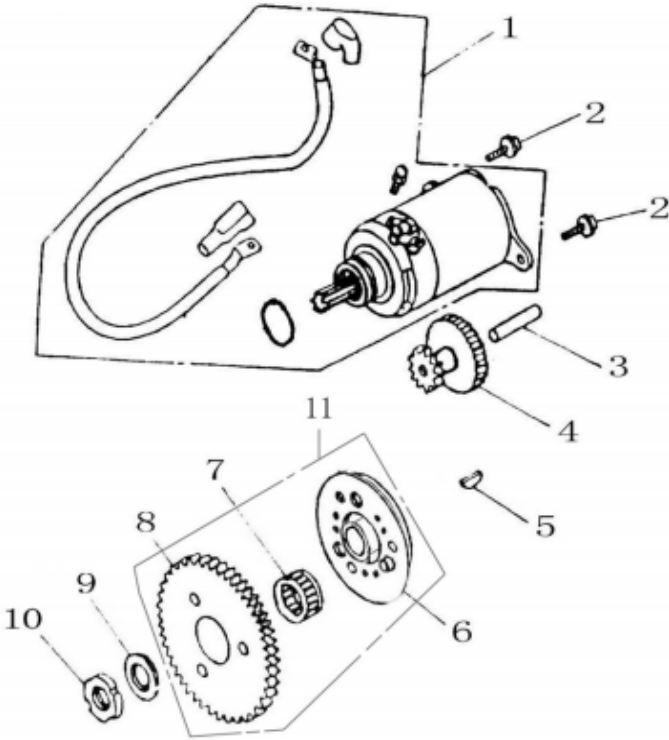

序	件号	中文名称	英文名称	数量	单价
---	----	------	------	----	----

NO	Code name	Chinese	Description	Q'ty	¥	\$
1	1.20.18.01.01000	起动电机总成	Starter Motor ASSY	1		
2	1.05.01.09.0616	螺栓M6×16	Bolt M6X16	2		
3	1.20.18.01.02000	齿轮轴	Starter Reduction Gear Shaft	1		
4	1.20.18.01.03000	过渡齿轮	Starter Reduction Gear	1		
5	1.20.09.01.01010	半圆键	Wooddruff Key	1		
6	1.20.19.08.01020	超越离合器组件	Overrunning Clutch ASSY	1		
7	1.20.19.01.01040	滚针轴承	Needle Bearing	1		
8	1.20.19.03.01030	从动齿轮组合	Driven bearing ASSY	1		
9	1.20.19.01.03000	垫片	Washer	1		
10	1.20.19.01.02000	锁紧螺母SM22×1左	Lock Nuts M22	1		
11	1.20.19.08.01000	起动超越离合器	Overrunning Clutch	1		

主、动皮带轮总成（一）

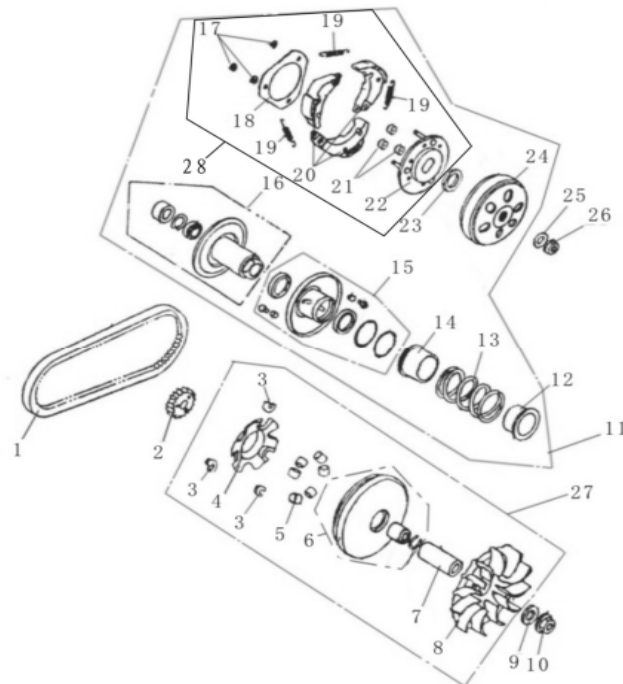



序	件号	中文名称	英文名称	数量	单价	
NO	Code name	Chinese	Description	Q'ty	¥	\$
1	157019000	齿形三角皮带842	V Belt	1		
2	1.20.17.08.04000	起动齿轮	Starter Gear	1		
3	1.20.21.01.01060	琅块	Weights	3		
4	1.20.21.01.01050	拖动法兰	Flange Plate	1		
5	1.20.21.01.01040	离心滚柱	Weight Tube	6		
6	1.20.21.01.01030	右主动轮组合	Right Driving Gear ASSY	1		
7	1.20.21.08.01020	衬套	Bushing	1		
8	1.20.21.01.01010	驱动皮带扇叶盘	Bladed Disc	1		
9	1.05.05.04.1200	垫圈12.3×29×2.5	Washer 12.3×29×2.5	1		
10	1.05.04.10.1213	螺母M12×1.25 H=10	Nut M12×1.25 H=10	1		
11	152160000	从动皮带轮总成	Driven gear ASSY	1		
25	1.05.05.04.1200	垫圈12.3×29×2.5	Washer 12.3×29×2.5	1		
26	1.05.04.10.1212	螺母M12×1.25 H=8	Nut M12×1.25 H=8	1		
27	1.20.21.08.01000	主动皮带轮总成	Driving Belt ASSY	1		

磁电机部件、机油泵部件

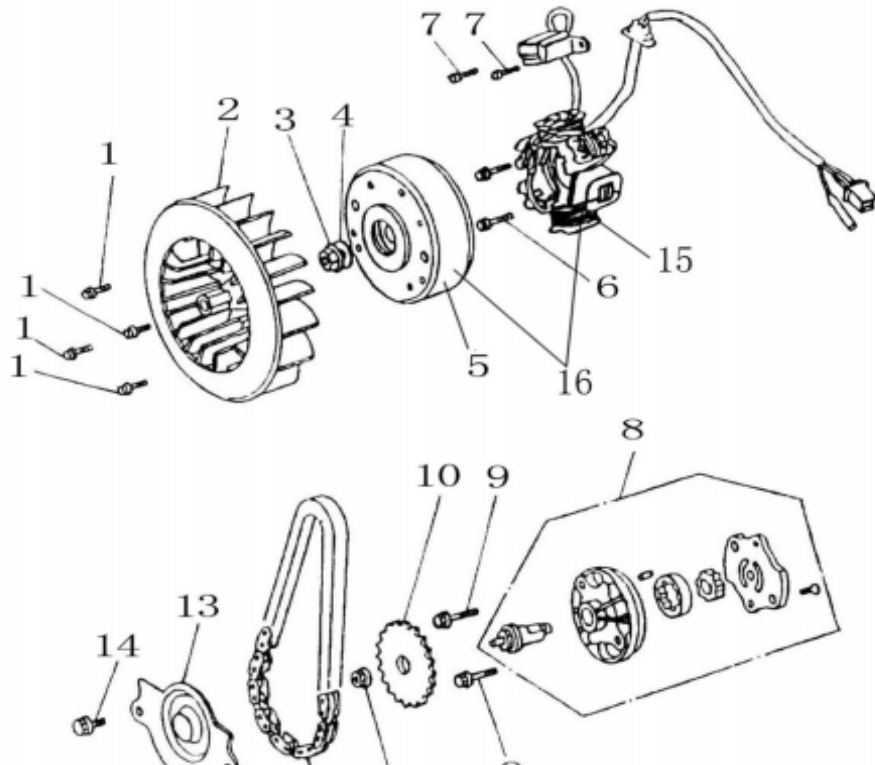

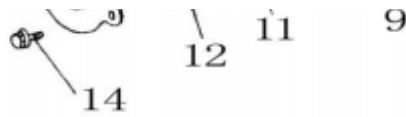

序	件号	中文名称	英文名称	数量	单价	
NO	Code name	Chinese	Description	Q'ty	¥	\$
1	1.05.01.09.0618	螺栓M6×18	Bolt M6X18	4		
2	1.20.24.01.06000	风扇组合	Fan Assy	1		
3	1.05.04.10.1213	螺母M12×1.25 H=10	Nut M12X1.25 H=10	1		
4	1.05.05.04.1201	平垫12-14HV	Washer 12-14 HV	1		
5	1.20.16.01.01020	飞轮	Flywheel(Rotor)	1		
6	1.05.01.09.0620	螺栓M6×20	Bolt M6X20	2		
7	1.05.01.08.0512	六角螺栓M5×12	Hex Bolt M5X12	2		
8	1.20.14.01.03000	机油泵组合	Oil Pump Assy	1		
9	1.05.01.09.0625	螺栓M6×25	Bolt M6X25	2		
10	1.20.14.01.01000	油泵链轮	Oil pump sprocket	1		
11	1.05.04.02.0600	螺母M6	Nut M6	1		
12	1.20.14.01.04000	油泵链条	Oil pump Chain	1		
13	1.20.14.01.02000	链轮端盖	Sprocket side Cover	1		
14	1.05.01.09.0612	螺栓M6×12	Bolt M6X12	2		
15	1.20.16.01.01011	定子组件 (直流8级)	Stator (DC 8 pole)	1		
15	1.20.16.01.01012	定子组件 (直流11级)	Stator (DC 11 pole)	1		
16	1.20.16.01.01001	磁电机总成 (直流8级)	Magneto (DC 8 pole)	1		
16	1.20.16.01.01002	磁电机总成 (直流11级)	Magneto (DC 11 pole)	1		

脚启动机构总成

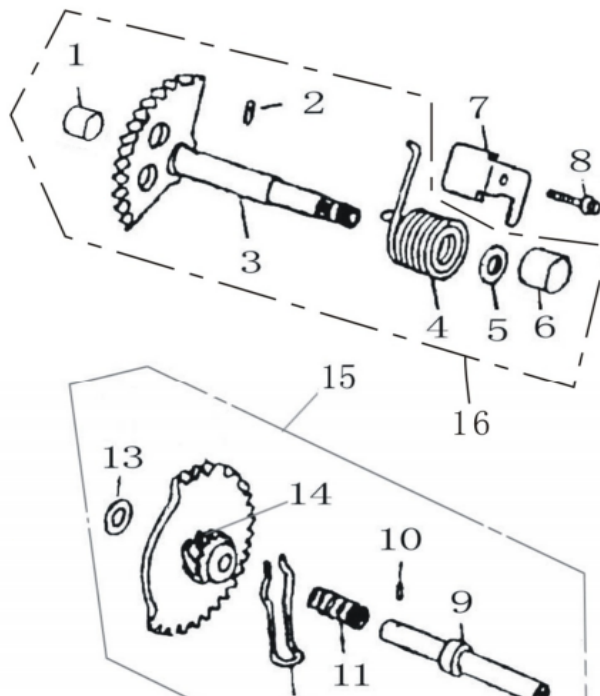

序	件号	中文名称	英文名称	数量	单价	
NO	Code name	Chinese	Description	Q'ty	¥	\$
1	1.20.17.01.01010	衬套 (I)	Bushing	1		
2		销	Pin	1		
3	1.20.17.01.01050	起动轴组合	Starter Shaft	1		
4	1.20.17.01.01020	扭簧	Spring	1		
5	1.20.17.01.01030	垫片	Washer	1		
6	1.20.17.01.01040	衬套 (II)	Bushing	1		
7	1.20.17.01.02000	起动扭簧压片	Spring Lock	1		
8	1.05.01.09.0614	螺栓M6×14	Bolt M6X14	1		
9	1.20.17.01.03030	惰轮轴	Starter Idle Shaft	1		
10	1.05.08.02.0308	圆柱销A3×8	Pin A3X8	1		
11	1.20.17.01.03020	压簧	Spring	1		
12	1.20.17.01.03050	叉簧	Fork Spring	1		
13	1.20.17.01.03040	调整垫片	Washer	1		
14	1.20.17.01.03010	斜齿轮	Starter Idle gear	1		
15	1.20.17.01.03000	惰轮组	Starter Idel Gear Assy	1		
16	1.20.17.01.01000	起动轴总成	Starter Shaft Assy	1		

## 导风罩分总成

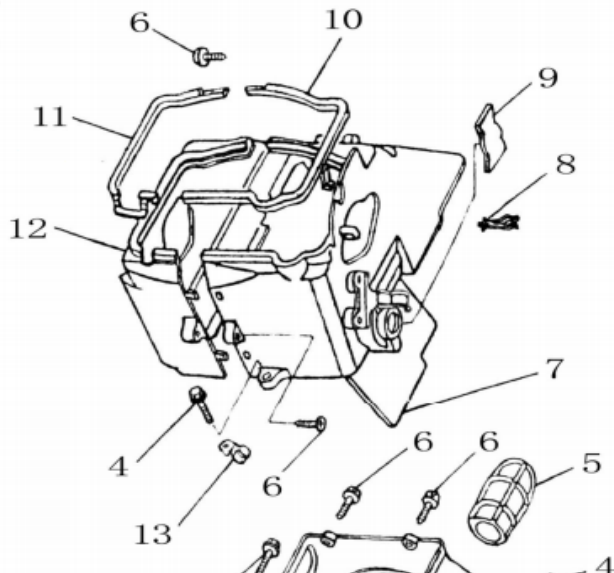

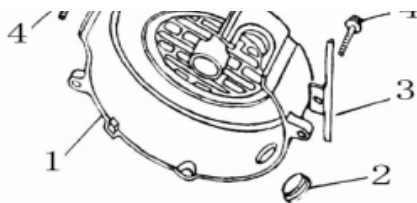

序 NO	件号 Code name	中文名称 Chinese	英文名称 Description	数量 Q'ty	单价	
					¥	\$
1	1.20.24.03.03000	风扇盖	Fan Cover	1		
2	1.20.24.01.03020	窗口堵盖	Plug Cap	1		
3	1.20.24.01.04000	电缆线夹	Wire Clip	1		
4	1.05.01.09.0625	螺栓M6×25	Bolt M6X25	3		
5	1.20.24.01.03010	冷却导管	Cooling Pipe	1		
6	1.05.02.15.4816	自攻螺钉ST4.8×16-F-H	Self-drilling screw	5		
7	1.20.24.06.01020	上导风罩组件	Air outlet Shroud (up)	1		
8	1.20.24.01.01040	高压线夹	Cable Clip	1		
9	1.20.24.01.01030	橡胶盖	Rubber Cap	1		
10	1.20.24.01.01010	上密封胶垫	Rubber Seal (up)	1		
11	1.20.24.01.02020	下密封胶垫	Rubber Seal (lower)	1		
12	1.20.24.06.02000	下导风罩组合	Air outlet Shroud (lower)	1		
13	1.20.24.01.05000	溢流管夹	Overflow pipe Clip	1		

**车架、搁脚组合 Frame and Accessories**

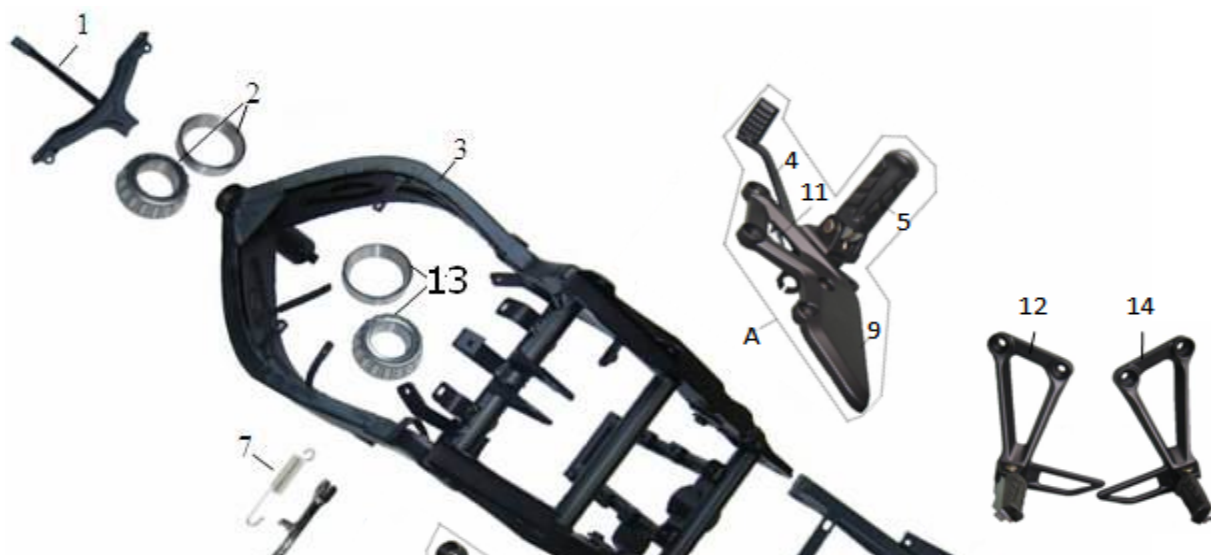



序 NO	件 号 Code name	中文名称 Chinese	英文名称 Description	数量 Q'ty	单价	
					¥	\$
1	02011021	头罩前支架	Headlight Fairing Stay	1		
2	12030046	320-22圆锥滚子轴承	Bearing 320-22	1		
3	0201-200SST	车架	Frame	1		
A	02050039	搁脚组合前右	Right Footrest (Front)	1		
4		刹车踏板	Brake Pedal	1		
5		搁脚	Footrest	1		
6	02011143	坐垫支架	Seat Frame	1		
7	07020061	单撑弹簧	Spring for Side stand	1		
8	02010424	单撑 CA250	Side Stand CA250	1		
9		前搁脚支架右	Right Footrest (Front)	1		
B	02050038	搁脚组合前左	Front Foot Peg (L.)	1		
10		前搁脚支架左	Left Footrest (Front)	1		
11		刹车踏板弹簧	Brake Pedal Spring	1		
12	02050040	搁脚组合后左	Rear Foot Peg (L.)	1		
13	12030047	320-23圆锥滚子轴承	Bearing 320-23	1		
14	02050041	搁脚组合后右	Right Foot Peg(R.)	1		

转向系统、前减震系统 Front Fork





序	件号	中文名称	英文名称	数量	单价	
NO	Code name	Chinese	Description	Q'ty	¥	\$
1	02030203	上联板	Upper Coonection Plate	1		
2	02030204	下联板	Lower Connection Plate	1		
3	02030202	手把管固定座右	Handle Bar lock (right)	1		
4	02030200	手把管	Handle Bar	2		
5	10010077	右组合开关	Right Switch Assy (Right)	1		
6	10020056	油门把套	Throttle Handle Grip	1		
7	02030201	手把管固定座右	Handle Bar Lock (Left)	1		
8	10010076	左组合开关	Left Switch Assy	1		
9	10020055	左把套	Left Handle Grip	1		
10	07010100	前减震器	Front Shock	1		
11				1		
12	09050002	(圆、橙色)反光片	Round Reflector (Orange)	2		
13	02011025	前泥板支架右	Front Fender Bracket (Right)	1		
14	02011024	前泥板支架左	Front Fender Bracket (Left)	1		
15	02030205	方向柱	Handlebar Riser	1		

消声器 Muffler







序	件号	中文名称	英文名称	数量	单价	
NO	Code name	Chinese	Description	Q'ty	¥	\$
1		螺栓M8x1.25x25	Hex Flange Bolt M8x1.25x25	2		
2	190408	抱箍	Muffler Clamp	2		
3	190406	硅胶垫	Silica Washer Sheet	2		
4	01050045	消声器筒体 (含附件)	Muffler	1		
5	190407	筒体与前管连接纸垫	Muffler Gasket	1		
6		螺栓8*16	Hex Flange Bolt M8X16	3		
7	01050051	消声器前管	Exhaust Pipe	1		
8	01990024	石棉垫	Asbestos Pad	1		
9		盖形螺帽6*32	HEX Cap Nut 6X32	2		

**油箱、后减震 Fuel Tank, Rear Shock**

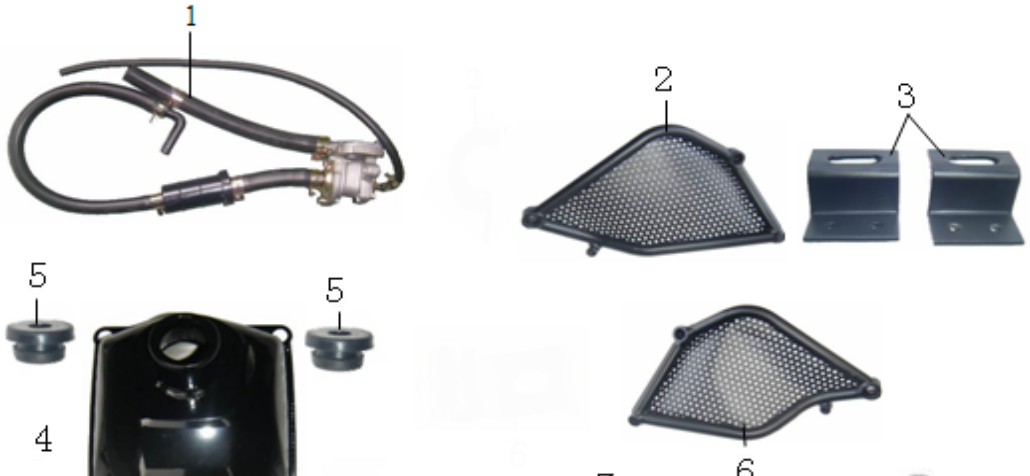



序 NO	件号 Code name	中文名称 Chinese	英文名称 Description	数量 Q'ty	单价	
					¥	\$
1	01990041	二次补气装置	Secondary Air Injection Device	1		
2	02011028	装饰网右	Body Mesh (right)	1		
3	02011029	电瓶盖扣板	Fixture Plate for Battery Cover	2		
4	05030036	油箱	Fuel Tank	1		
5	06020013	油箱缓冲垫 (带衬套)	Fuel Tank Plate	4		
7	02011027	装饰网左	Body Mesh (Left)	1		
8	07010112	后减震	Rear Shock Absorber	1		

轮毂 Tires





序	件号	中文名称	英文名称	数量	单价	
NO	Code name	Chinese	Description	Q'ty	¥	\$
1	06010014	轮胎130/60-13	Tire 130/60-13	2		
2	02040024	前轮毂	Front Rim	1		
3	12030050	轴承	Bearing	2		
4	190015	气门嘴	Valve Stem	2		
5	02040128	后轮毂	Rear Rim	1		
6	10040015	计速器（带2线夹）	Speed Hub	1		
7	10040055	车速传感器	Speed Sensor	1		

前碟刹 Front Disc Brake System

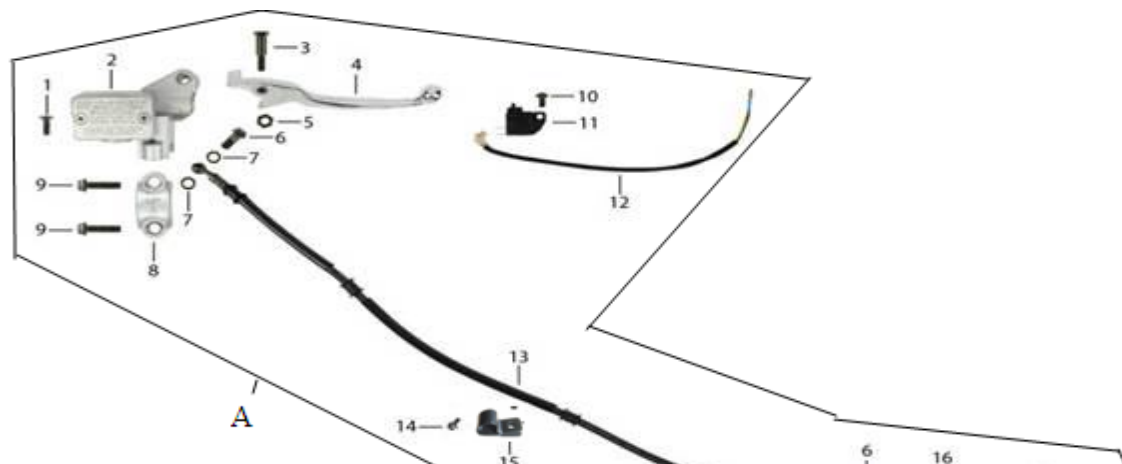

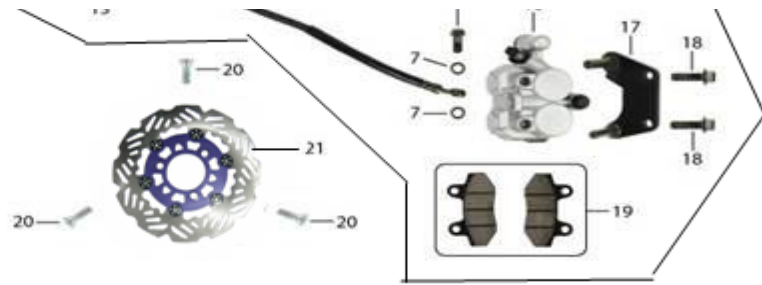

序 NO	件号 Code name	中文名称 Chinese	英文名称 Description	数量 Q'ty	单价 ¥      \$	
A	04010067	前碟刹总成	Front Disc Brake ASSY	1		
1		平头十字槽螺钉M4X. 7X10	Phillips Screw M4X.7X10	1		
2	190191	前刹上泵	Upper Pump	1		
3		台阶螺栓, M5X. 8X23	HEX Shoulder Bolt M5X.8X23	1		
4		杆, 前刹车	Front Brake Lever	1		
5		六角螺母, M5X. 8	HEX Nut M5X.8	1		
6		螺栓M10X1. 25X22	Bolt M10X1.25X22	1		
7		垫圈	Washer	1		
8		压板	Master Cylinder Clamp	1		
9		六角法兰螺栓, M6X1. 0X20	Hex Flange Bolt M6X1.0X20	1		
10		平头十字槽螺钉, M4X. 7X7	Screw M4X.7X7	1		
11	190043	方(形)碟刹开关(右)	Microswitch	1		
12		制动开关线	Microswitch Cable	1		
13	190411	前制动油管	Front Brake Hose	1		
14		六角法兰螺栓, M6X1. 0X12	Hex Flange Bolt M6X1.0X12	1		
15	12990030	碟刹管线夹	Brake Hose Retainer	3		
16	190192	前刹下泵(带支架)	Front Caliper Bracket	1		
17		支架,	Caliper Bracket	1		
18		六角法兰螺栓, M8X1. 25X25	Hex Flange Bolt M8X1.25X25	1		
19	190041	前刹车片	Front Brake Pad	1		
20		台阶螺栓, M8X1. 25X25	Shoulder Bolt M8X1.25X25	1		
21	04020037	前碟盘	Front Brake Disc	1		

### 后碟刹 Rear Disc Brake

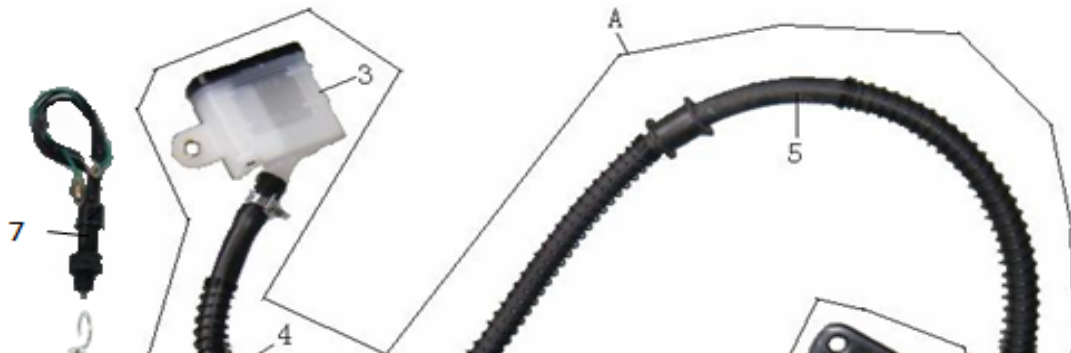

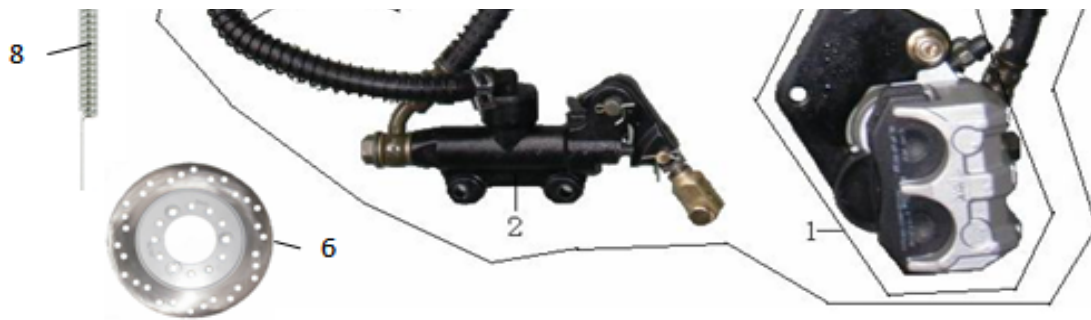

序 NO	件号 Code name	中文名称 Chinese	英文名称 Description	数量 Q'ty	单价 ¥      \$	
A	04010073	后碟刹总成	Rear Disc Brake ASSY	1		
1	190423	后制动泵（带支架）	Rear Brake Pump(With Bracket)	1		
2	190422	后碟刹总泵	Rear Master Cylinder	1		
3	190424	方形斜嘴油杯	Oil Pump	1		
4	190421	输油管	Oil Pipe	1		
5	190420	后制动油管	Rear Brake Hose	1		
6	04020006	碟盘（后）	Rear Brake Disc	1		
7	10010035	刹车开关	Brake Switch	1		
8	07020007	刹车开关拉簧	Brake Switch Tension Spring	1		

仪表、电缆、锁 Instrument, Cable

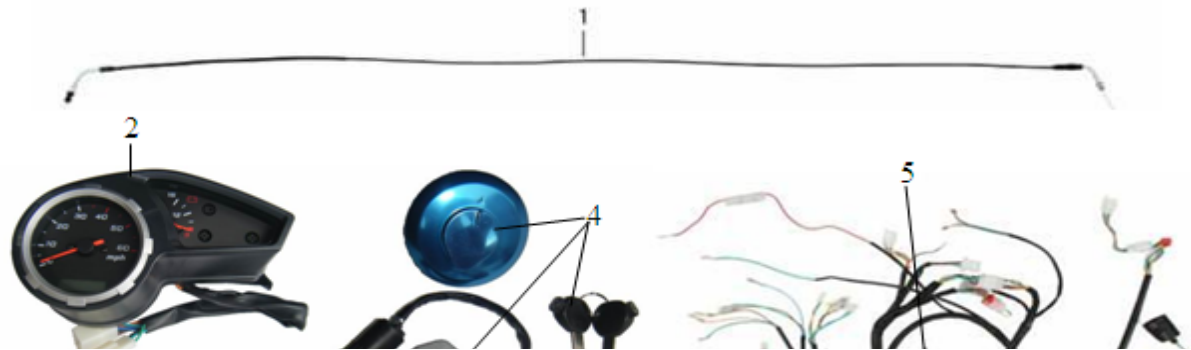



序 NO	件号 Code name	中文名称 Chinese		英文名称 Description	数量 Q'ty	单价 Price	
						¥	\$
1	08020206	油门线		Throttle Cable	1		
2	10050063	仪表		Speedmeter	1		
3	02011026	仪表支架		Speedmeter Bracket	1		
4	10080039	套锁		Switch Lock	1		
5	08010078	电缆线		Wire Harness	1		

### 灯具 Lights





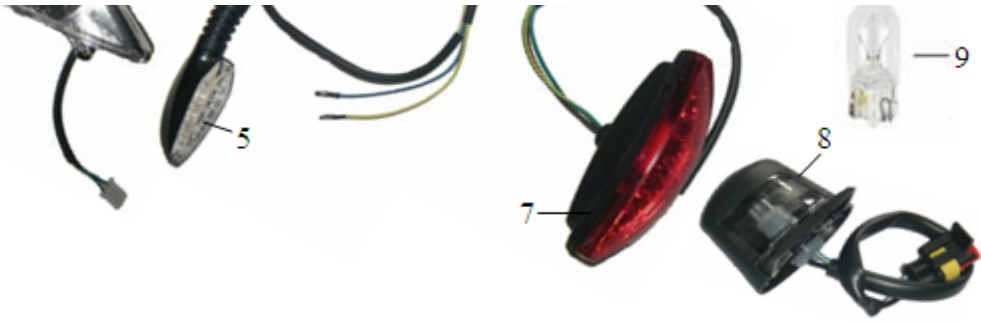

序 NO	件号 Code name	中文名称 Chinese	英文名称 Description	数量 Q'ty	单价 ¥ \$	
1	09020110	前左转向灯	Front Turn light (Left)	1		
2	09020111	前右转向灯	Front Turn light (Right)	1		
3	09010051	大灯左	Head Light (Left)	1		
4	09010052	大灯右	Head Light (Right)	1		
5	09020112	后左转向灯	Rear Turn Light (Left)	1		
6	09020113	后右转向灯	Rear Turn Light (Right)	1		
7	09030050	后尾灯	Tail Light	1		
8	09030052	牌照灯	Licence Plate Light	1		
9	00608015	12V5W灯泡	Bulb 12V5W	1		
10	09010056	12V35/35W灯泡	Bulb 12V 35/35W	2		

**覆盖件1 Body Covering 1**

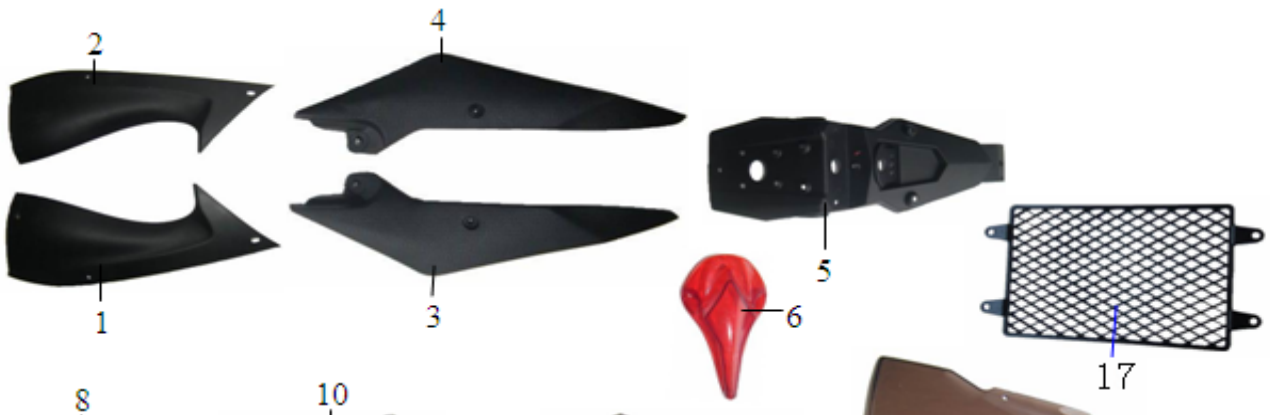



序 NO	件号 Code name	中文名称 Chinese	英文名称 Description	数量 Q'ty	单价	
					¥	\$
1	03030592	油箱边侧板左	Fuel Tank Guard (Left)	1		
2	03030593	油箱边侧板右	Fuel Tank Guard (Right)	1		
3	03030590	侧板左	Body Guard (Left)	1		
4	03030591	侧板右	Body Guard (Right)	1		
5	03030594	后泥板	Rear Fender	1		
6	03030600	鹰嘴	Red Decorating for Headlight fairing	1		
7	03030597	下网罩左	Bottom Mesh Guard (Left)	1		
8	03030598	下网罩右	Bottom Mesh Guard (Right)	1		
9	03030595	上网罩左	Up Mesh Guard (Left)	1		
10	03030596	上网罩右	Up Mesh Guard (Right)	1		
11	03010389	尾灯壳	Tail Light Cover	1		
12	03030599	挡风玻璃	Windshield	1		
13	03030589	电池盒	Battery Tank	1		
14	03030493	电池盒盖	Battery Tank Cover	1		
15	02011014	后泥板固定板	Rear Wheel Fender Plate	1		
16	09050001	反光片 (方-红)	Square Reflector (Red)	1		
17	03030422	G300网罩	G300 Net Cover	1		
18	03030311	工具箱	Tools Box	1		

**覆盖件2 Body Covering 2**

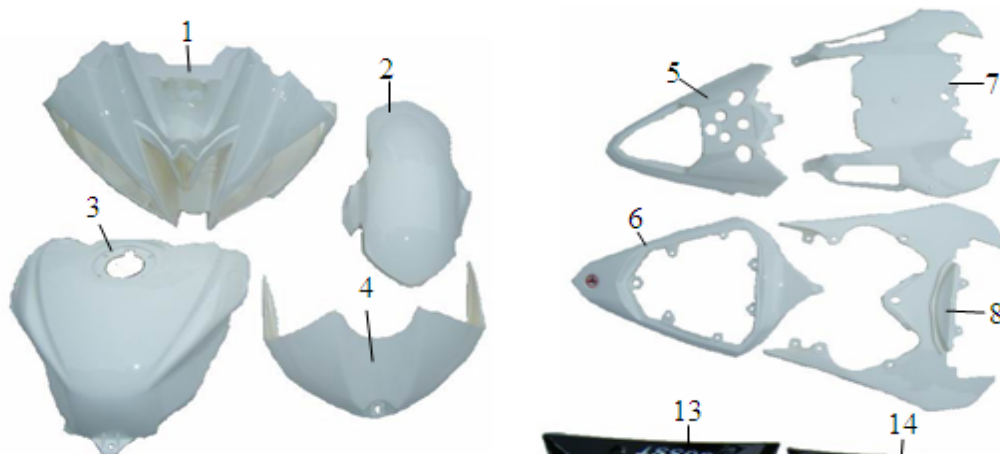

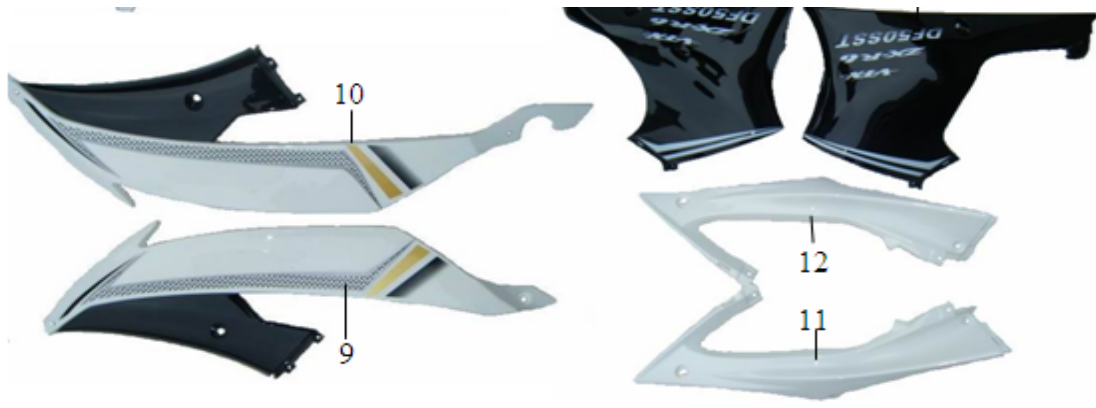

序 NO	件 号 Code name	中文名称 Chinese	英文名称 Description	数量 Q'ty	单价	
					¥	\$
1	03010379	头罩	Headlight Fairing	1		
2	03010375	前泥板	Front Fender	1		
3	03010380	油箱壳主体	Fuel Tank Cover	1		
4	03010382	油箱罩前部	Front Fuel Tank Cover	1		
5	03010376	后尾下体A	Up Tail Body	1		
6	03010387	后尾上体B	Bottom Tail Body	1		
7	03010388	前座下体B	Bottom Seat Fairing	1		
8	03010381	前座上体A	Up Seat Fairing	1		
9	03010383	头罩边短侧板左	Headlight Side Fairing (Left)	1		
10	03010384	头罩边短侧板右	Headlight Side Fairing (Right)	1		
11	03010385	装饰板左	Body Fairing (Left)	1		
12	03010386	装饰板右	Body Fairing (Right)	1		
13	03010377	大侧板左	Bottom Fairing (Left)	1		
14	03010378	大侧板右	Bottom Fairing (Right)	1		

**坐垫、后视镜 Seat, Mirror**



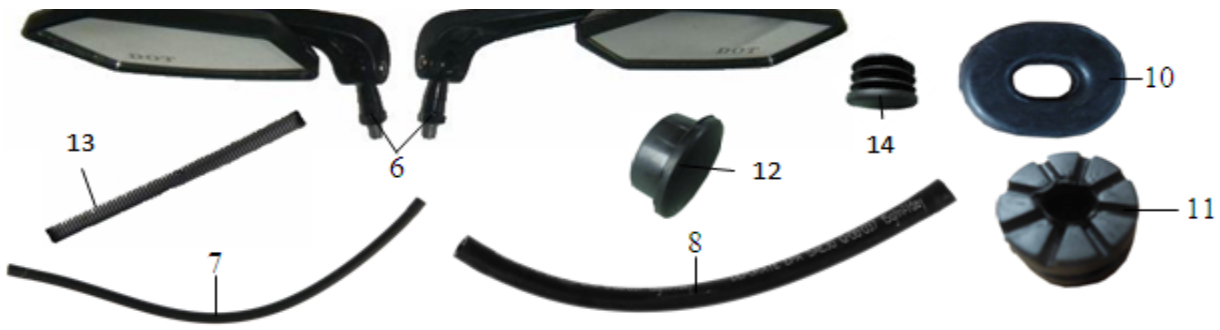

序	件号	中文名称	英文名称	数量	单价	
NO	Code name	Chinese	Description	Q'ty	¥	\$
1	05010050	坐垫后	Passenger Seat	1		
2	05010049	坐垫前	Driver Seat	1		
3	06990001	二级过滤器	Secondary Fuel Filter	1		
4	12010010	钢丝卡子6	Iron Clamp	2		
5	10060001	油箱开关	Pet Cock	1		
6	09060021	后视镜	Rear View Mirror	1		
7	06030001	真空管4*7	Gas Pipe 4*7	45cm		
8	06030002	汽油管4.5/8.5	Fuel Pipe 4.5/8.5	65cm		
9	12010007	油管夹8.5	Fuel Pipe Clamp 8.5	8		
10	06020045	椭圆工字形橡胶圈	Rubber Ring	1		
11	06020018	工字形胶圈	Rubber Fastener	3		
12	06020015	橡胶管塞38	Rubber Plug 38	2		
13	07020003	油管防护弹簧	Tubing Protective Spring	1		
14	06020102	橡胶塞子φ25	Rubber Plugφ25	1		

**电器、电瓶 Electric Components**

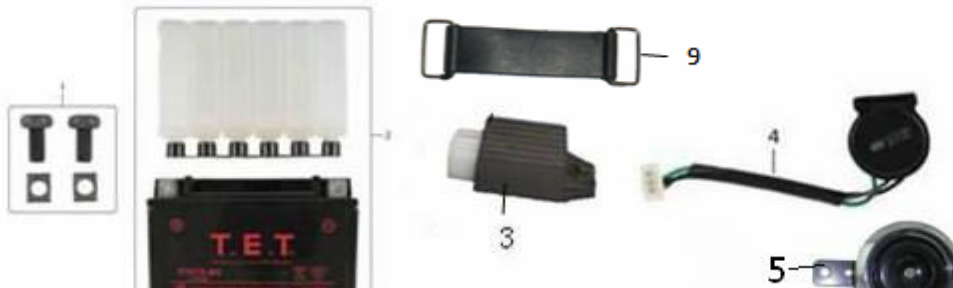

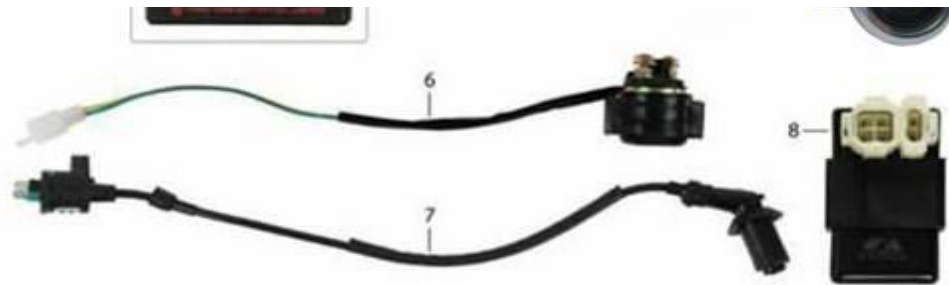

序 NO	件号 Code name	中文名称 Chinese	英文名称 Description	数量 Q'ty	单价	
					¥	\$
1	10990001	螺栓	Battery Bolts	1		
2	10990001	电瓶YTX7A-BS	Battery (YTX7A-BS)	1		
3	01020018	整流器	Regulator	1		
4	01020011	闪光器	Flasher (Turn signal relay)	1		
5	10070001	喇叭	Horn	1		
6	01020021	继电器	Relay	1		
7	01020022	高压包	Ignition Coil	1		
8	01020016	点火器	CDI	1		
9	06990062	电瓶扎带	Battery Fastener Pad	1		

**随车工具 Tools Kit**





序	件号	中文名称	英文名称	数量	单价	
NO	Code name	Chinese	Description	Q'ty	¥	\$
A		随车工具	Tools	1		
1	16010005	12-14开口扳手	Open Spanner(12-14)	1		
2	16010004	8-10开口扳手	Open Spanner(8-10)	1		
3	16010006	双头螺丝刀	Dual-Purpose Screwdriver	1		
4	16010007	火花塞套筒S=16	Spark Plug Box Spanner(S=16)	1		
5	16010002	6mm内六角扳手	Socket Head Screw Wrench(6mm)	1		
6	16010001	5mm内六角扳手	Socket Head Screw Wrench(5mm)	1		
7	16010116	4mm内六角扳手	Socket Head Screw Wrench(4mm)	1		