

## SPECIFICATION

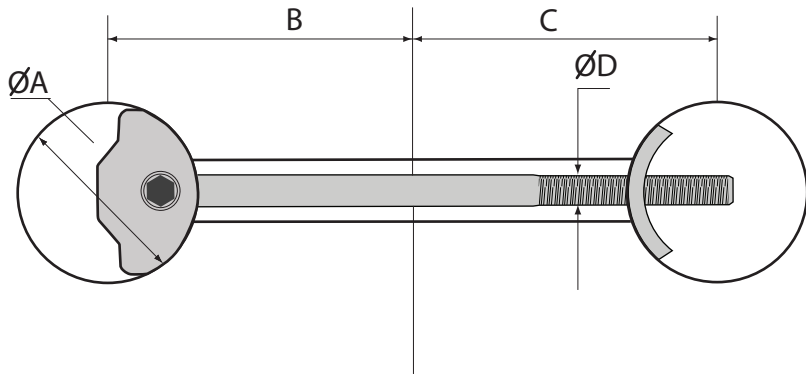

### SHAFT CENTRE CALCULATION

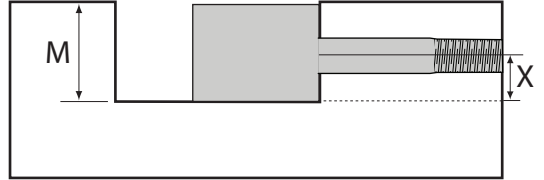

M= Minimum Bore Depth 20mm (51/64 inches)  
 X = Shaft Centre 10mm (25/64 inches)

## Measurements

|   | Millimetres | Inches  |
|---|-------------|---|
| A | 35          | 1 <sup>3</sup> / <sub>8</sub>                                     |
| B | 74 - 87     | 2 <sup>29</sup> / <sub>32</sub> - 3 <sup>27</sup> / <sub>64</sub> |
| C | 74 - 87     | 2 <sup>29</sup> / <sub>32</sub> - 3 <sup>27</sup> / <sub>64</sub> |
| D | 6           | 1 <sup>5</sup> / <sub>64</sub>                                    |

