



Description

Transform your workouts with the Bench Fitness EXCEED Multi Lift, featuring free-moving arms with rotating knurled D handles and a set of knurled 32mm adjustable handles for push movements. Each arm is fitted with height adjustable range limiters and bumper pin to adjust your workouts. Fitted with a central adjustable split squat padding and 4 storage bumper pins, the EXCEED Multi Lift is ready for full body workouts.

At Bench Fitness, we strive to exceed expectations, and our Exceed Plate loaded machines exemplify this philosophy. You can customize the complete range of machines with an extensive range of colors and even add your own branding for a personalized touch. Additionally, all Exceed plate loaded machines are compatible with our REVOLVE band pegs, which can help you take your workouts to the next level.



Multi position knurled handles



Rotating D handles

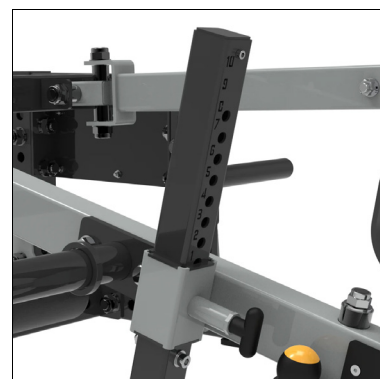

Adjustable range limiters

Features

- 10 year structural warranty
- 300mm bench width
- 1 inch black zinc bolts
- Bench wrench included for easy assembly

Specifications

Material:	75mm x 75mm steel tube frame
Length:	1865mm
Height:	561mm
Width:	1724 (end of bumper pins)
Weight:	162kg





Dimensions

