

# Boori

## Universal



## Changing Tray

*for Smart Assembly Chest*

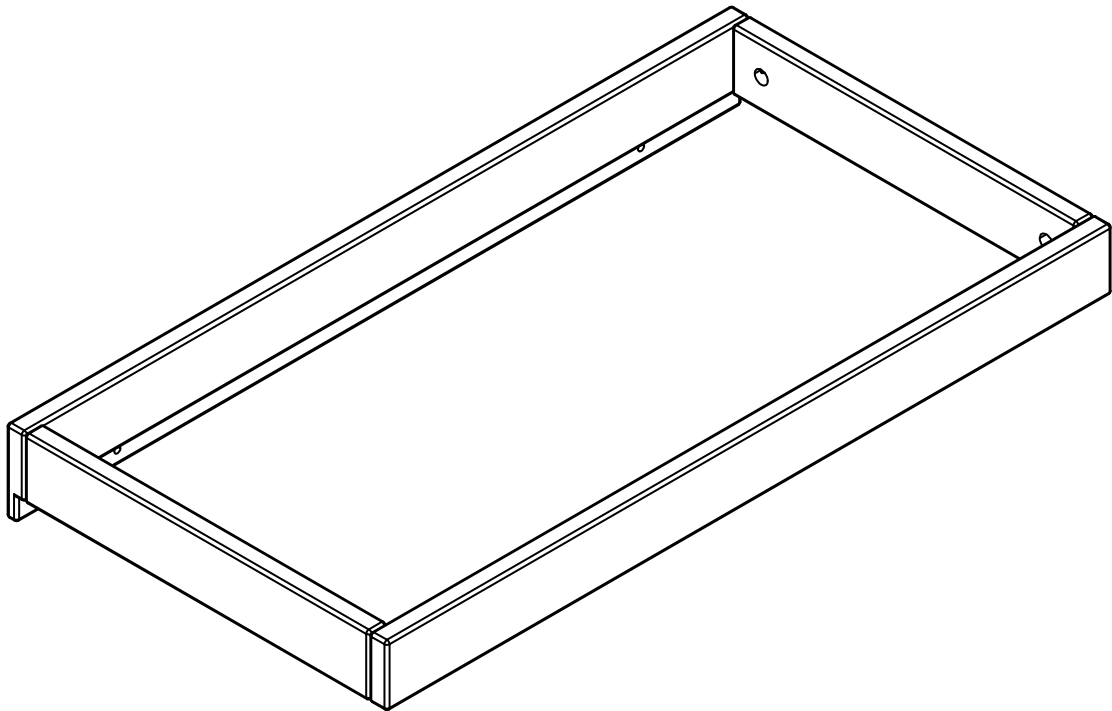

**IMPORTANT:**

**PLEASE READ THE INSTRUCTIONS CAREFULLY  
AND KEEP FOR FUTURE REFERENCE**

**Boori Australia Pty Ltd**  
 26 Peter Brock Drive  
 Eastern Creek NSW  
 2766 Australia  
 Tel: +61 2 9833 3769  
 Fax: +61 2 9673 4240  
 www.boori.com.au

**Boori (Europe) Ltd**  
 Unit 1 Riverside House,  
 Mill Lane, Newbury,  
 Berkshire, RG 14 5QS UK  
 Tel: +44 016 3529 5670  
 Fax: +44 016 3587 7552  
 www.boori.co.uk

**Halim & Boori Company**  
 10F. Halim INT'L B/D, #1674-4,  
 Seocho-Dong, Seocho-Gu,  
 Seoul, Korea  
 Tel: +82 2598 1470  
 Fax: +82 2583 8885  
 E-mail : ted@boori.co.kr  
 Postal code: 137-725.

ブーリジャパン株式会社  
 〒141-0031  
 東京都品川区西五反田  
 7-22-17 TOCビル5F  
 TEL:03-6420-0024  
 EMAIL:info@boori.co.jp  
 HP:www.boori.jp



上海薇奈莎商贸有限公司  
 博瑞儿童用品(上海)有限公司  
 上海市盈港东路6433号1幢B区101室  
 邮编: 201703  
 电话: +86 21 5296 6600  
 传真: +86 21 5296 6636  
 网址: www.boori.com.cn

## Universal Changing Tray For Smart Assembly Chest (B-CTSA)

Dimensions /External : 842\*442\*95(mm)

Main Materials: Australian Araucaria

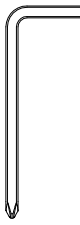
### Hardware

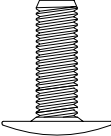
A x 1	B x 4	C x 4	D x 2
			 M5*30mm

### Parts List

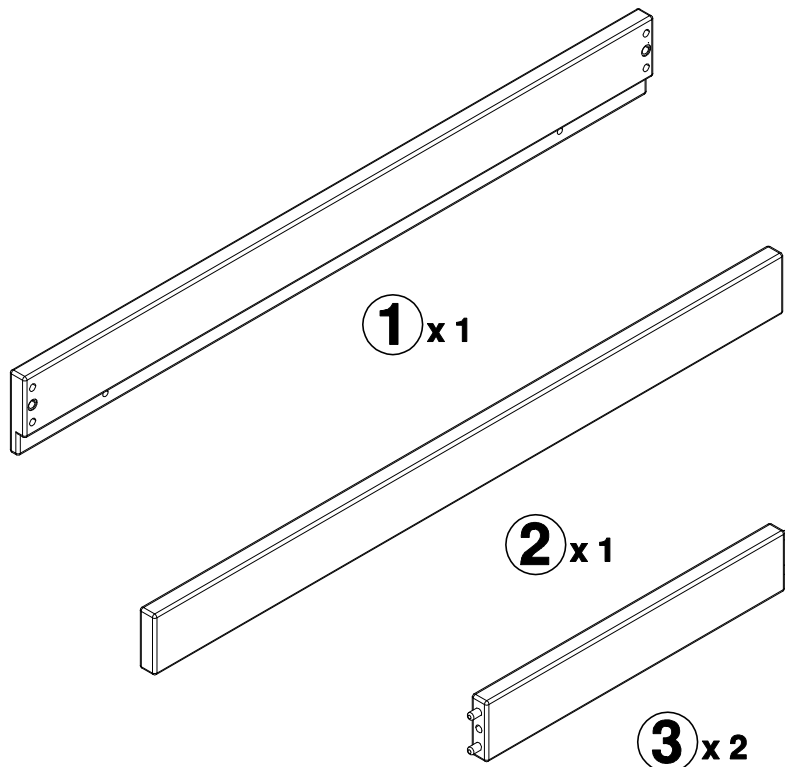

NOTE: Use only spare parts approved by the manufacturer.

# Assembly

1

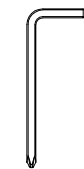
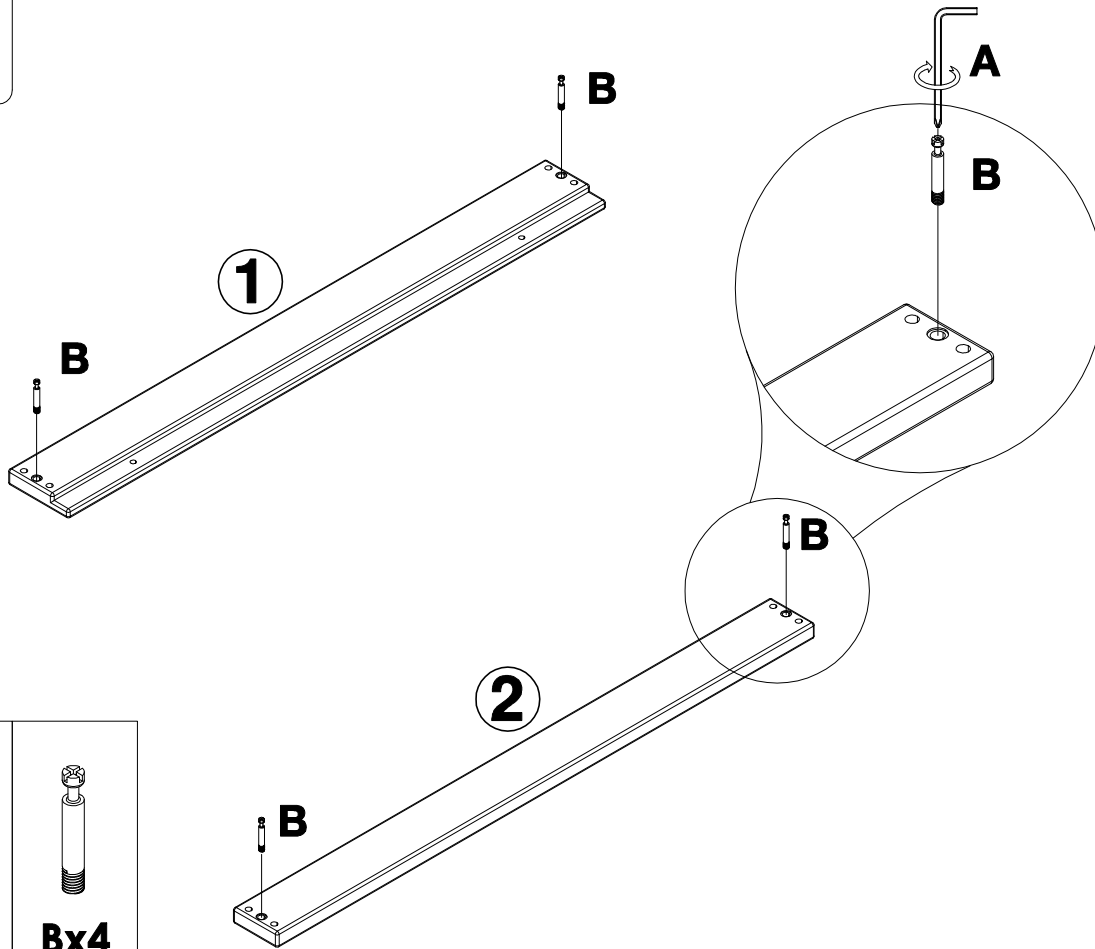

Ax1



Bx4

2

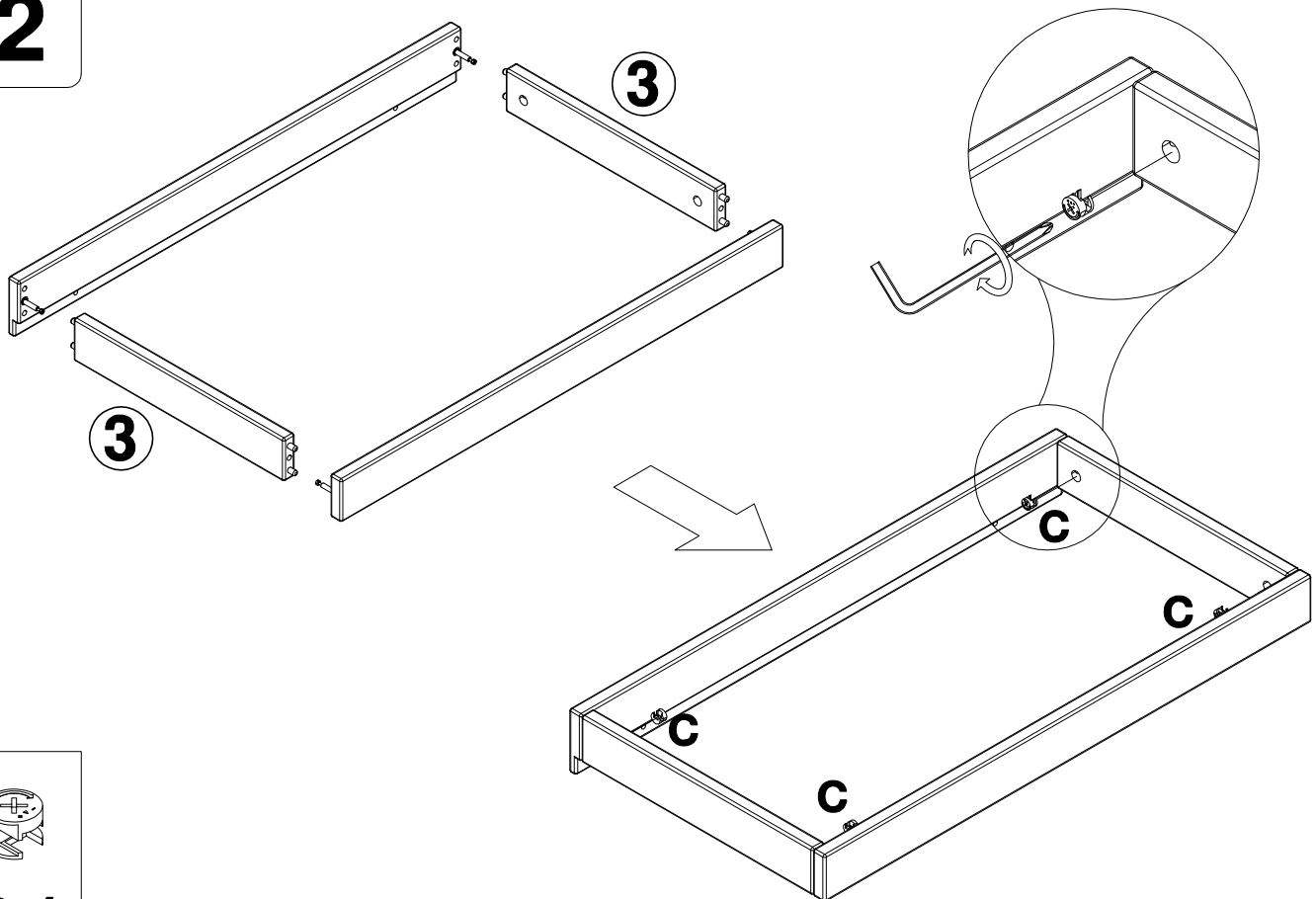

Cx4

# Assembly

3

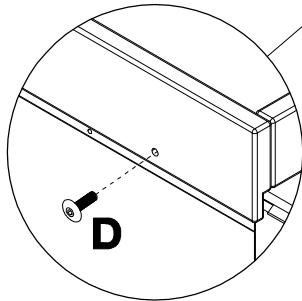
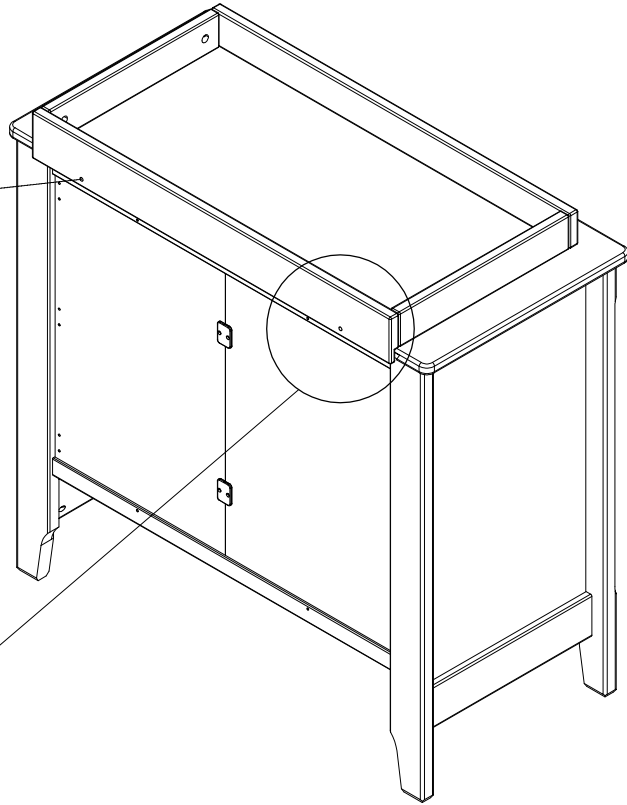
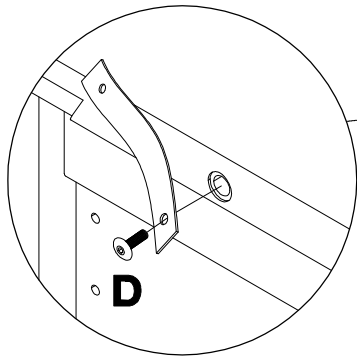

Dx2

4

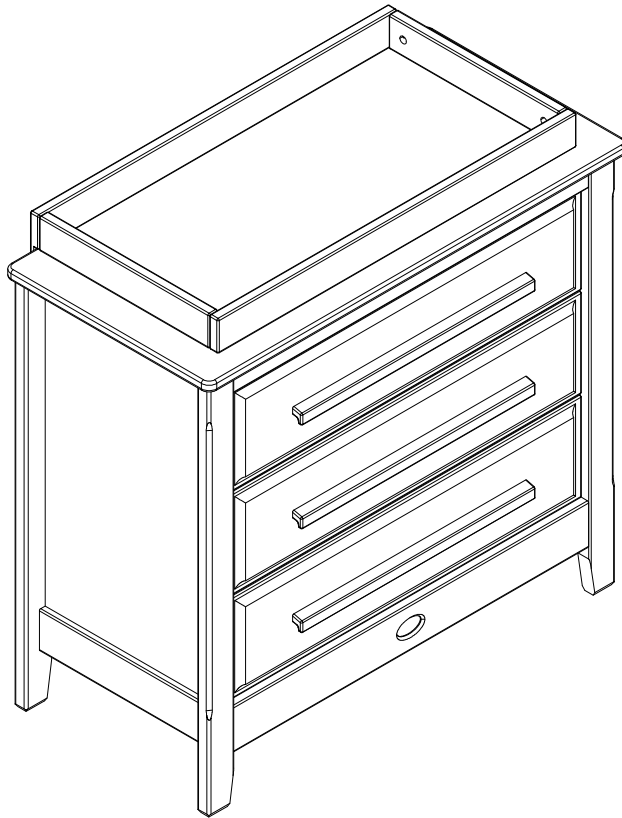

**Important:** The assembled furniture must be placed adjacent to the wall and fixed to the wall using the appropriate screw for that wall type. If you are in any doubt about the correct type of fitting to use, please seek professional advice.

# Boori Furniture

**NOTE:** Use only spare parts approved by the manufacturer

**FOR THE UK**

**EN 12221-1/-2:2008+A1:2013**

**⚠ WARNING:** Do not leave the child unattended

\* This product is not intended to be used as a table. Use of the product without instruction may result in death or serious injury to your child from falling.

Follow all instructions on attaching and using the changer.

\* When lockable castors/wheels are fitted, they shall be locked when the changing units is in use.

\* All assembly fittings shall always be correctly tightened and checked regularly.

\* Be aware of the risk of open fires and other sources of strong heat, such as electric bar fires, gas fires, etc. in the near vicinity of the changing unit.

\* Recommended pad size is shown on carton marking.

\* This product is intended for children under 12 months, and lighter than 11kg.

\* Any additional or replacement parts shall only be obtained from the manufacturer or distributor.

\* Not to use the changing unit when any part is broken, torn or missing.

**FOR THE USA**

**( ASTM F 2388:2009 )**

**⚠ WARNING:** Do not leave the child unattended

## 1. **FALL HAZARD:**

To prevent death or serious injury, always keep child within arm's reach.

2. Read all instructions before use of the changing table, add-on changing unit, or contoured changing pad.

3. Keep instructions for future use.

4. Do not use changing table, add-on changing unit, or contoured changing pad if it is damaged or broken.

5. Recommended pad size is shown on carton marking.

6. This product is intended for children under 12 months, and lighter than 11kg.



# Warranty against defects

---

**For Australia only** (updated 01/01/2012)

## **Boori Australia Pty Ltd**

18-20 Charles Street, St.Marys Sydney Nsw 2760 Australia

PH:(61 2) 9833 3769 FAX:(61 2) 9673 4240

ABN: 43 160 962 354

## **Boori Care Instructions**

Congratulations and thank you for choosing Boori product(s). The furniture you have purchased is constructed from high quality materials for strength and durability. Here are some tips on how you can preserve its beauty for a long time.

1. Do not expose furniture to strong sunlight, direct heat sources, extreme changes in temperature or moisture.
2. Wipe up spills immediately with a soft, clean cloth.
3. Urine spills on furniture can cause discolouration.
4. Clean furniture by wiping the surface with a soft cloth dampened with water.
5. If necessary clean furniture using a mild soap solution and wipe clean with a soft cloth dampened with water and then dry with soft clean cloth.
6. Do not use strong household cleaners.
7. Always wipe in the direction of the grain in the wood do not wipe in a circular motion.
8. Avoid contact with sharp objects, or containers containing hot liquid.
9. Avoid contact with 'rubber feet' on items such as radios, computers, telephones etc. Use a felt mat (not plastic) to protect furniture surfaces.
10. Do not open more than one drawer at a time.
11. When moving furniture do not drag, always lift and place in position.

## **Boori Warranty (“this Warranty”)**

All Boori Waratah Collection products (“Boori Waratah Products”) (including mattresses) carry a full one (1) year manufacturer’s warranty (“Warranty Period”) to the end-purchaser (“the Customer”) as testimony to the quality and longevity of the range. This warranty excludes general wear & tear and damage caused, by the Boori Waratah Product not being used in accordance with its instructions or the care instructions. During this Warranty Period Boori Australia Pty Ltd (ABN 43 160 962 354) (“Boori”) will replace or repair any defective part. In the event of a Boori Waratah Product being replaced, as a whole unit or part thereof during the Warranty Period, the warranty on the replacement will expire one (1)years from the original purchase date.

This guarantee excludes accidental damage, misuse and or improper transporting and handling.

The warranty is void if the original Boori Product has been altered in design or colour in anyway.

**All warranty claims must be lodged:**

- 1. at the place of original purchase as set out on your receipt for purchase of the Boori Products or you may contact Boori on 9833 3769 to obtain further details;and**
- 2. together with a proof of purchase.**

Where the Customer makes a claim pursuant to this Warranty, all expenses incurred in sending the Boori Products to Boori are the Customer's responsibility.

Boori's liability in respect of a breach of a consumer guarantee or any warranty made under this Warranty for any Boori Products not of a kind ordinarily acquired for personal, domestic or household use is limited, in relation to the Boori Products to the extent permissible by law and at it's option to:

1. replacing the Boori Products or the supply of equivalent Boori Products;
2. the repair of the Boori Products;
3. the payment of the cost of replacing the Boori Products or of acquiring equivalent goods; or
4. the payment of the cost of having the Boori Products repaired.

To the extent permitted by law, all other warranties whether implied or otherwise, not set out in this Warranty are excluded and Boori is not liable in contract, tort (including, without limitation, negligence or breach of statutory duty) or otherwise to compensate the Customer for:

1. any increased costs or expenses;
2. any loss of profit, revenue, business, contracts or anticipated savings;
3. any loss or expense resulting from a claim by a third party; or
4. any special, indirect or consequential loss or damage of any nature whatsoever caused by the Customer's failure in complying with its obligations.

**Limitations on Warranty Disclaimers**

In the following paragraph, 'Our' means 'Boori', 'You' means 'the Customer' and 'goods' means 'Boori Products':

*Our goods come with guarantees that cannot be excluded under the Australian Consumer Law. You are entitled to a replacement or refund for a major failure and for compensation for any other reasonably foreseeable loss or damage. You are also entitled to have the goods repaired or replaced if the goods fail to be of acceptable quality and the failure does not amount to a major failure.*

The benefits given to the Customer in this Warranty are in addition to other rights and remedies under a law in relation to the Boori Products to which this warranty applies.