

# Easy Set Up\*

- ① Install lower foot lever to Pump Jack

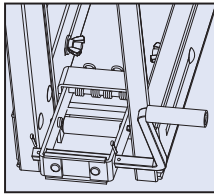

- ② Install Pump Jack to pole

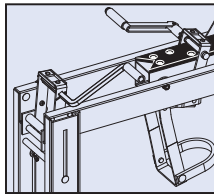

- ③ Install work bench to Pump Jack

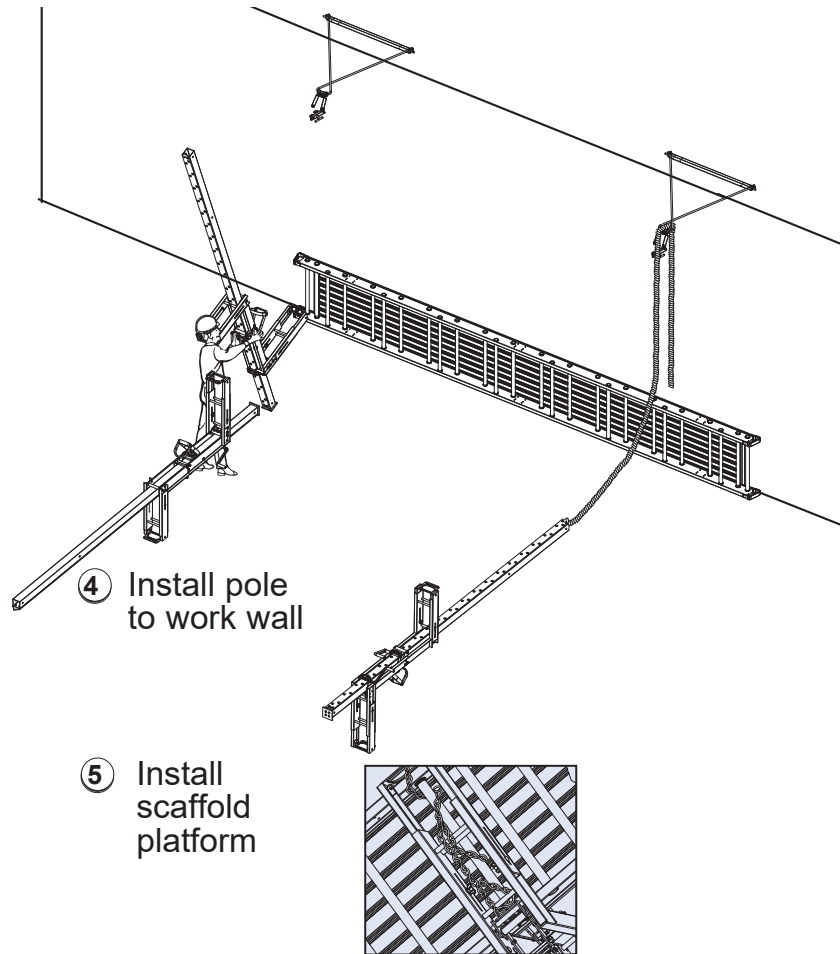
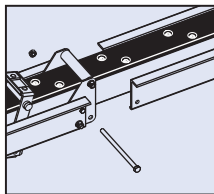

## Aluminum Poles

Durable design for all types of weather.

Available lengths:

6', 12', 18', 24'

Pole connector

Pole pad

Connector pins

Pole connector

\* Note: Be sure to follow all safety and assembly instructions.



The #1 Brand in Professional Climbing Equipment.

# MORE PRODUCTIVITY WITH LESS DOWN TIME

## The Werner Pump Jack System

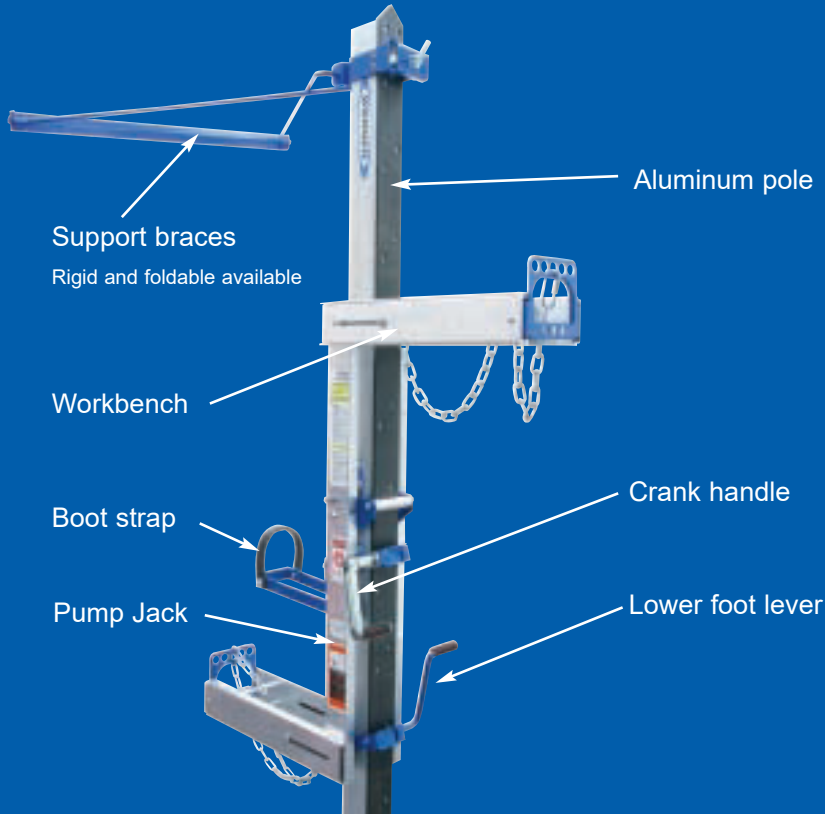

## Why Werner

### Ease of Operation

**Crank handle** is easily unlocked and allows for effortless rotation while lowering the pump jack

### Strength and Durability

**Aluminum frame "Z" channel** (U.S. Patent Pending) is **20%** stronger than leading competitor

**Powder coated** end plate provides rigid chain attachment to maintain position during use

## Nestable Stages

- Continuous work platform reduces trip hazard
- 2 Person – 500 lbs. Rated

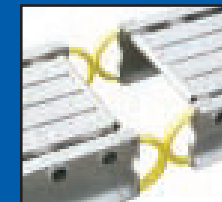

## Safety is Job One



### End Rail Kit

- Easy to assemble
- Attaches to any stage
- Available in various widths



### 22' Safety Net

- Easy to attach
- Stores tools and debris for vertical fall protection

## Available Sizes

WNS 2412	14"x12' Stage
WNS 2416	14"x16' Stage
WNS 2420	14"x20' Stage
WNS 2424	14"x24' Stage
WNS 2512	20"x12' Stage
WNS 2516	20"x16' Stage
WNS 2520	20"x20' Stage
WNS 2524	20"x24' Stage
WNS 2612	24"x12' Stage
WNS 2616	24"x16' Stage
WNS 2620	24"x20' Stage
WNS 2624	24"x24' Stage



**EDMONTON  
SCAFFOLDING**  
By Alberta Drywall

[www.edmontonscaffolding.com](http://www.edmontonscaffolding.com)



# ALUMINUM PUMP JACK SYSTEM



## SAFETY AND ASSEMBLY INSTRUCTIONS

When used in accordance with instructions, this product meets

**ANSI Standards  
and**

**U.S. Department of Labor  
O.S.H.A.  
Regulations**

**WARNING! READ AND UNDERSTAND ALL INSTRUCTIONS BEFORE USE. Failure to comply with these instructions may result in serious injury**

### WORKSITE CONDITIONS

1. Ensure worksite is free of construction debris.
2. DANGER! Metal conducts electricity. Never use near any electrical current.
3. Inspect all power tools and extension cords to ensure they are not damaged. Damaged tools and cords can cause serious injury.

### SPECIAL PRECAUTIONS

1. Inspect total system upon receipt and at least once each day or before each shift when in use.
2. Never use equipment with damaged or missing parts. Discard or contact manufacturer for repair or replacement.
3. Follow manufacturer's instructions when using approved components with the Werner pump jack system.
4. Check all parts for good condition. Lightly lubricate moving parts occasionally.
5. Acids (hydrochloric, muriatic, etc.) and caustics (caustic soda, trisodium phosphate, etc.) are corrosive to aluminum and can seriously affect its strength. Do not expose to corrosive substances.
6. Discard any components exposed to excessive heat or corrosive material.
7. Do not use in inclement weather or high winds. Windy conditions require extra caution. Scaffold platforms must be secured against wind uplift.
8. If people pass under or nearby, use safety screening of No. 19 gage US standard wire 1/2" mesh. Cover space between toeboard and top guard rail on all open sides and ends of scaffold platform.
9. Provide overhead protection not more than 9 ft. above the working plank or pedestrian walkway where overhead hazard exists.
10. The use of fall protection equipment is always recommended. Safety codes require guard rails and toeboards on all open sides when scaffold platform height is 10 feet or more, and may be required at lower heights, depending on the application and jurisdiction. Check applicable ANSI, OSHA, state and local codes for specific requirements.
11. If the pump jack system will be used in the absence of a wall, a four sided guard rail system must be used.
12. Safety belt, harness, lanyard and lifeline use must comply with ANSI A10.8, A10.14, and A120.1, OSHA and all applicable federal, state and local codes.
13. All equipment shall be secured to or removed from scaffold platform. Never throw or drop tools or materials to the ground.

### COMPATIBILITY

1. Werner pump jack **system components**, identified in the next section, are designed and manufactured to be used with Alum-A-Pole Pump Jack System.
2. It is the user's responsibility to ensure that product is functioning properly when interchanging Werner and Alum-A-Pole Pump Jack **system components**.
3. Never replace individual pieces or parts of the **system components** unless supplied by Werner Co.
4. Call Werner Co. at 724-588-8600 with any questions regarding compatibility of **system components**.

### SYSTEM COMPONENTS

1. Make sure you read and understand the compatibility section of this manual.
2. Wooden poles may not be used with Werner aluminum pump jack systems.
3. See list of **system components** with model numbers below.

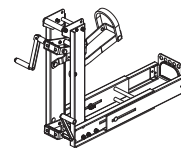

Pump Jack - Model# PJ-100

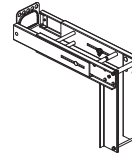

Work Bench - Model# PJ-WB



6' Pole - Model# PJ-6P  
12' Pole - Model# PJ-12P  
18' Pole - Model# PJ-18P  
24' Pole - Model# PJ-24P



Pole Connector - Model# PJ-PC

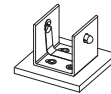

Pole Foot - Model# PJ-PF

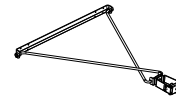

Rigid Support Brace - Model# PJ-SBR

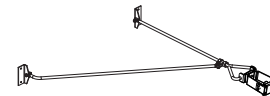

Foldable Support Brace - Model# PJ-SBF

### INSTALLATION OF LOWER FOOT LEVER ON PUMP JACK

1. Slide lower foot lever through square holes in bottom shackle assembly of pump jack. Ensure rod is installed through square holes on both sides of shackle assembly.

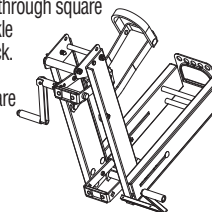

2. Slide cotter pin through small holes located on each end of handle rod and bend cotter pins to prevent the rod from sliding out of position.

Cotter Pins

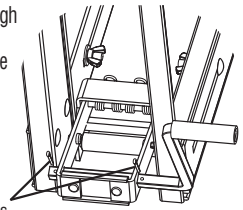

### INSTALLATION OF PUMP JACK TO POLE

1. Place aluminum pump jack pole on ground with rubber pad facing upward.
2. Place pump jack on ground with platform support extending down toward ground.
3. Slide bottom end of pole (with V-shaped notch) through top of pump jack. Ensure pump jack platform support is facing the ground while pole's rubber surface is facing up.

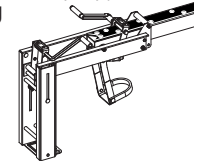

4. Continue to slide pole through pump jack until pole is advanced past lower foot lever of pump jack causing lower foot lever to depress into rubber surface of pole. Note: Lower foot lever may need to be disengaged to allow pole rubber surface to slide past.

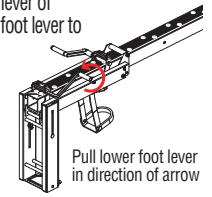

5. Pump upper foot lever to advance pump jack until it is approximately one foot past bottom of pole.

### INSTALLATION OF WORK BENCH TO PUMP JACK AND POLE

1. Remove nut and bolt from vertical members of work bench.
2. With pole in same position on ground as when pump jack was assembled, slide work bench through top of pole with the work bench platform support extending up in same direction as pump jack pole rubber surface.

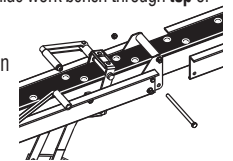

3. Reinstall lower nut and bolt through holes in work bench where they were removed as well as through blue connector plates of pump jack.

4. Work bench should ride on top of pump jack with its platform support extending opposite that of pump jack.

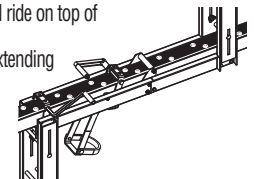

**WARNING! DO NOT STAND OR SIT ON WORK BENCH, WHILE IN USE**

## INSTALLATION OF POLE TO WORK WALL

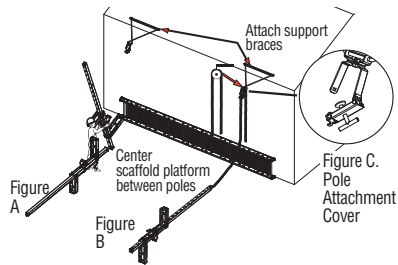

1. Install pole foot into bottom of pole. Ensure button locks are securely snapped into holes on pole.
2. Erect Pump Jack system on firm ground. When working on soil, plywood should be used in order to form a solid plate under the Werner pole foot.
3. Do not install pole on top of scaffold platforms or on roof surfaces.
4. Attach support braces to structure to be worked on using at least four screws with a minimum holding strength equivalent to 1/4" x 3" type AB screws (See Figure above). Attach support braces to both top and bottom of pole and other points as necessary. (See section for "Installation of Intermediate Braces To Pole.")
5. Place pole with pump jack and work bench assemblies on ground. Ensure rubber surface of pole is facing down toward ground with bottom of pole pointing toward work wall of structure (see Figure A above) or rubber surface of pole is facing upward with top of pole pointing toward work wall of structure (see Figure B above).
6. Align pole assembly with support braces that were attached to structure.
7. Place scaffold platform on its side against work wall with top surface of scaffold platform facing work wall.
8. Center scaffold platform between pole assemblies, ensuring that a rung of the scaffold platform is aligned with appropriate attachment point on the pump jack (see Figure above).
9. Swing Pole upward assuring that scaffold platform will not be further than 14" from wall. **Note:** It is recommended that a rope be used to hoist pole for any pole combination in excess of 24'. Rope should be pulled through cross members of support brace and used to pull top of pole up to brace. A pulley can also be attached to support brace to aid in hoisting pole.
10. Secure support brace to pole by latching and tightening support brace pole attachment cover. Ensure cover is tight against rubber surface of pole (see Figure C above).

**WARNING! NO WORK LOAD IS PERMITTED ON THE PUMP JACK SYSTEM DURING THIS PROCESS**

11. Secure scaffold platform to pump jack using the supplied chain. See instruction section "Installation of Scaffold Platforms" for details on how to secure chain.

## INSTALLATION OF SCAFFOLD PLATFORMS

1. Extend platform support of each Pump Jack to the actual width of scaffold platform and secure in place by tightening fasteners along the side of pump jack platform support.

2. Scaffold platforms shall overhang supports a minimum of 6 inches and a maximum of 18 inches on each end unless access is restricted to the cantilevered end. Do not load overhang. When platforms are lapped, ends must be overlapped a minimum of 12 inches. Support at overlap with rigid support. Platform overhang and overlap must meet OSHA and all applicable federal, state, and local codes.
3. Secure scaffold platform to each pump jack using chain and hardware provided. Chain shall be routed around scaffold platform rung and around each of the spacers, which are integral to the pump jack as shown in the figure below. Chain may be secured to platform support end plate using the provided chain quick link. A padlock may be used for added security.
4. Always install pump jack system so scaffold platform used for standing or working is level.
5. Do not install a scaffold platform more than 14" from working wall. There shall be no opening greater than 14" anywhere surrounding the working person.

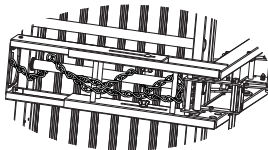

## INSTALLATION OF INTERMEDIATE BRACES TO POLE

**WARNING! ANY APPLICATION OVER 24' HIGH REQUIRES THE USE OF INTERMEDIATE SUPPORT BRACES HAVING A MAXIMUM VERTICAL SPACING OF 16'. SOMEONE COMPETENT SHALL ENSURE THAT ALL BRACES ARE ATTACHED TO SOLID MATERIAL WITH ADEQUATE HOLDING POWER. A MINIMUM TORQUE OF 5 FT/LBS. SHOULD BE REQUIRED ON THE SCREW HEAD USED TO SECURE THE BRACE.**

1. Secure support brace to pole at required height.
2. Push support brace out to a vertical surface. It is very important that the surface is vertical to ensure pump jack will not bind on pole while in use.
3. Fasten support brace to structure using at least four screws with a minimum holding strength equivalent to 1/4" x 3" type AB screws.

## PASSING AN INTERMEDIATE BRACE

1. In order to pass a support brace that is already installed, a temporary support brace should be installed approximately 4 feet above support brace to be passed.
2. Worker should assume a position on scaffold platform which allows the first support brace to be released and reattached.
3. Release support brace from pole.
4. Once pump jack has been moved past the support brace, the support brace should be reattached to pole and the temporary support brace can be removed.

## INSTALLATION OF POLE CONNECTOR TO JOIN POLES TOGETHER

1. Orient two poles with rubber facing in the same direction and v-shaped rubber protruding from top of lower pole to mate with v-shaped cut on bottom of upper pole (see figures below).



2. Insert pole connector into either top of lower pole or bottom of the upper pole allowing button locks on pole connector to engage into holes located on side of pole. It will be necessary to depress button locks so they can bypass end surface of pole. Ensure button locks are securely snapped into holes to lock pole connector in position.
3. Insert remaining exposed end of pole connector into second pole and ensure button locks are fully engaged.
4. Inspect to ensure rubber surfaces mate together without more than a 3/8" gap and without overlapping or bulging.

## RAISING SCAFFOLD PLATFORM

1. Ensure crank handle mechanism is locked into position with locking teeth engaged. Crank handle mechanism must be locked during use and raising of scaffold platform.
2. While standing on the scaffold platform and facing pole, place foot under the strap on upper foot lever and pump to raise system until scaffold platform is raised approximately one foot.
3. Repeat procedure with additional pump jacks in system until desired height is reached. Maximum allowable working height is 48'.

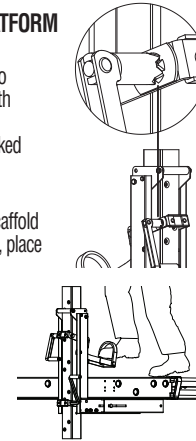

**WARNING! WORK MUST ALWAYS BE PERFORMED ON A LEVEL PLATFORM TO AVOID INJURY.**

4. Return pump jack foot lever to fully up position for use.

## LOWERING SCAFFOLD PLATFORM

1. While standing on scaffold platform and facing pole, confirm upper foot lever is in fully up position and crank handle mechanism is locked into position.
2. Using right foot fully depress upper foot lever.

**WARNING! PRESSURE MUST BE MAINTAINED ON UPPER FOOT LEVER DURING STEP 3. FAILURE TO MAINTAIN PRESSURE WILL ALLOW THE UPPER FOOT LEVER TO ROTATE RAPIDLY UPWARD AND MAY CAUSE INJURY.**

3. While holding onto pole, place left foot on lower foot lever. Push and hold to point of release.
4. Rotate crank handle outward to disengage locking teeth.
5. Rotate crank handle in a clockwise direction to lower system approximately one foot.
6. Rotate crank handle back into locked position with teeth engaged. Release lower foot lever to re-engage.

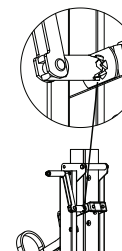
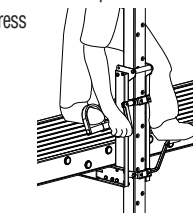

Ensure upper foot lever is returned to fully up position.

7. Repeat procedure with additional pump jacks in system until desired height is reached.

## GENERAL USE

1. Only trained personnel shall erect and/or use this equipment.
2. Examine erected system thoroughly to ensure it is set up properly.
3. Make sure pump jack system installation does not violate any federal, state or local codes.
4. Never overload system! Maximum load not to exceed load capacity of lowest rated component in system. See other labels and instructions.
5. There should never be more than two people on pump jack system between any two poles.
6. Never drop or apply an impact load to system components.
7. **Do not use ladders on scaffold platform or on pump jacks.**
8. Do not accumulate materials or debris on scaffold platform.
9. Remove foreign substances such as mud, grease or oil from shoes and all **system components** before use.
10. Do not use ladders to climb onto or off scaffold platform unless ladder and platform are secured against movement.

## PROPER MAINTENANCE, CARE AND STORAGE

1. Consult manufacturer to replace worn **system components**.
2. Always keep components clean of all foreign materials.
3. Properly support and restrain pump jack **system components** in transit or storage. Wear damage from vibration may weaken **system components**.
4. For additional care, use, and safety instructions, contact your employer, dealer or the product manufacturer. See additional labels on all **system components**.

**WARNING! FAILURE TO COMPLY WITH THESE INSTRUCTIONS MAY RESULT IN SERIOUS INJURY.**



WERNER CO.,  
93 WERNER ROAD  
GREENVILLE, PA 16125-9499  
PHONE (724) 588-8600  
www.wernerladder.com