

WLP Series | Advanced Wash Water Recycle Systems

These recycle systems are designed to remove free hydrocarbons and filter the water to be sent back through a pressure washer. They come standard with pH and ORP injection. All systems are designed with corrosion-resistant stainless-steel tanks.



WLP Series recycle systems combine enhanced design with state-of-the-art technology to offer:

- Quality recycled wash water without common odor problems
- Easy operation and maintenance
- Poly skid is constructed of hardened polymer to be non-corrosive. It can also be easily lifted and moved with a forklift from all four sides.
- CSA approved control panel which meets the requirements of the US and Canadian standards for an Industrial Control Panel



WLP-20-0M10

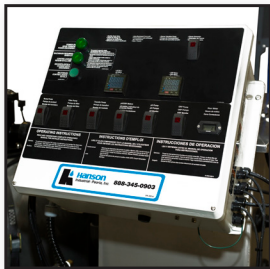

CSA listed NEMA-4 rated corrosion-proof control panel for safe and reliable operation



Hose connectors are clearly marked and designed for easy accessibility and quick installation



Pumps are easily accessible



Recommended Air Compressor AM1-HE02-05M for use with the auto-backwash models

AM1-HE02-05M
4.2 CFM @ 90 PSI
2.0 HP, 120V, 15.0A Electric Motor
5-Gallon Twin Tank Receiver



WLP Series | Advanced Wash Water Recycle Systems



Model Number	Flow Rate	Media Filter (Custom Mix)	Cartridge Filter	Carbon Filter (Degassed)	Power Requirements	Air Required	Dimensions (LxWxH)	Ship Wt.
WLP-08-0M10	0-8 GPM	350 lb.	100 sq. ft.	110 lb.	230V, 1Ø, 21.0A	-	6ft.x5ft.x52in.	1475 lb.
WLP-20-0M10	0-20 GPM	550 lb.	400 sq. ft.	110 lb.	230V, 1Ø, 25.0A	-	8ft.x5ft.x52in.	2435 lb.
WLP-20AB-0M11 *	0-20 GPM	550 lb.	-	110 lb.	230V, 1Ø, 25.0A	60 to 100-PSI	8ft.x5ft.x52in.	2435 lb.
WLP-20AB-0M31 *	0-20 GPM	550 lb.	-	110 lb.	230V, 3Ø, 13.0A	60 to 100-PSI	8ft.x5ft.x52in.	2435 lb.
WLP-30-0M10	0-30 GPM	500 lb.	400 sq. ft.	110 lb.	230V, 1Ø, 30.0A	-	8ft.x5ft.x52in.	2735 lb.
WLP-40-0M10	0-40 GPM	900 lb.	600 sq. ft.	165 lb.	230V, 1Ø, 30.0A	-	(2) 8ft.x5ft.x60in.	3200 lb.
WLP-40AB-0M11 *	0-40 GPM	900 lb.	-	165 lb.	230V, 1Ø, 30.0A	60 to 100-PSI	7ft.x9ft.x60in.	3100 lb.
WLP-40AB-0M31 *	0-40 GPM	900 lb.	-	165 lb.	230V, 3Ø, 17.0A	60 to 100-PSI	7ft.x9ft.x60in.	3100 lb.

*Auto-backwash models (air required 60 to 100-PSI)
230/208/460V 3-phase available on all models as options.

Accessories:		
Part Number	Description	Fits Models
32-0538	pH probe - Keeps water at an appropriate pH level so the germicide is effective at killing bacteria and controlling odor	All models
32-0540	ORP probe - Measures and injects a germicide to control odor by killing odor-causing bacteria	All models
32-0693	pH probe (self-cleaning) - Keeps water at an appropriate pH level so the germicide is effective at killing bacteria and controlling odor	All models
55-1887	Check valve, 2-inch - Holds prime in suction line	All models
AT-4007	Replacement air filter - Moisture trapping replacement filter	Auto-backwash models

Replacement Filter Elements:		
Part Number	Description	Fits Models
19-0263	Filter - Replacement filter for #19-0627, 30-micron, 150 sq. ft., 3 filters needed	WLP-08
19-0264	Filter - Replacement filter for #19-0630, 30-micron, 400 sq. ft., 3 filters needed	WLP-20 & WLP-30
19-0265	Filter - Replacement filter for #19-0631, 30-micron, 500 sq. ft., 3 filters needed	WLP-40
19-0274	Filter - Replacement filter for #19-0632, 30-micron, 100 sq. ft., 1 filter needed	WLP-08



Filter, 19-0265

Replacement Media:		
Part Number	Description	Fits Models
33-0302	Activated carbon - Order per pound	All models
33-0303	Gravel #3 - Order per pound	All models
33-0304	Garnet #12 - Order per pound	All models
33-0305	Garnet #50 - Order per pound	All models
33-0306	Filter ag - Order per pound	All models
33-0318	Organoclay - Custom media, order per pound	All models
33-0403	Garnet #80 - Order per pound	All models
33-0449	Large funnel - Funnel helps you load media	All models
33-0450	Zeolites - Custom media, best for red clay, 50 lb. bag, order per pound	All models



Activated Carbon



Gravel #3



Garnet #12



Garnet #50



Filter Ag



Organoclay



Garnet #80

WLP Series | Process and Flow Description



- 1. Surface-Mount Sump Pump** - Untreated wash water is introduced into the system via a 1.0 HP surface-mount sump pump, which is included with the system, located on the unit.
- 2. Corona Discharge Ozone System** - Wash water is injected with a high concentration of ozone via a corona discharge ozone injector system for a "quick kill" of live bacteria on contact. Ozone also breaks up emulsified oils, allowing them to coalesce and float to the top of the tank for separation into the oil decanter.
- 3. Advanced Oil/Water/Solids Separator** - As the water flows through the three-stage oil/water/solids separator, it changes directions countless times as the water is directed and redirected through four horizontal baffles and hundreds of square feet of honey-combed-shaped meshed oleophilic (oil-attracting) coalescing media. Mechanically emulsified oil particles are attracted from the water to the oleophilic media and float to the surface. Once on the surface, the oil is skimmed off into an oil decanter for easy disposal. Fine silt and particulates are dropped to the bottom of the sloped stainless-steel tank for easy flushing and disposal of the accumulated solids.
- 4. ORP/pH Controller** - For longer term control of bacteria, the ORP injection system automatically measures and injects a germicide to control odor by killing odor-causing bacteria. The automated pH control system keeps the water at an appropriate pH level so the germicide is effective at killing bacteria and controlling odor.
- 5. Customized Multi-Media Filter** - Once the water has been treated for oil and solids removal, it is then pushed through a customized multi-media filter which contains a special media blend to filter out particulates down to 25-microns.
- 6. Activated Carbon Filter** - The final treatment stage of the system occurs as the water is filtered through activated carbon which absorbs hydrocarbons, herbicides, pesticides, metals and dozens of other carbon-based constituents. Activated carbon also works as a polisher for treated water to remove chlorides.
- 7. Treated Water in Holding Tank** - Once the water is treated, it is pressurized where it will be ready for reuse at 30-PSI to 50-PSI.
- 8. Electrical Control Panel** - CSA listed NEMA-4 rated corrosion-proof control panel for safe and reliable operation.

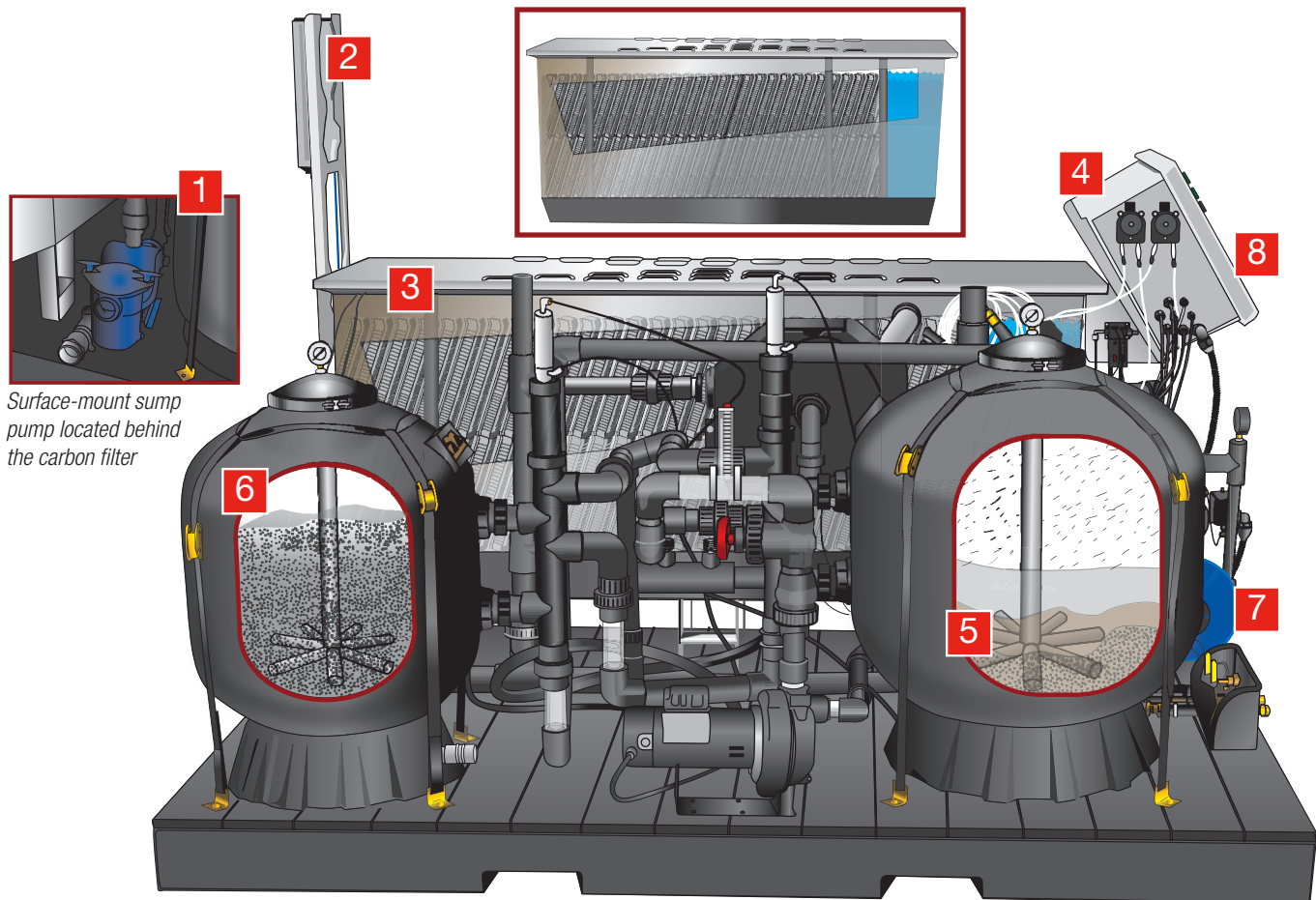

Surface-mount sump pump located behind the carbon filter

WLP Series | Sample Equipment Wash Pad Application



The WLP Series is perfect for the following applications:

- Rental Yards
- Heavy Equipment Dealers
- Trucking Facilities
- Military Bases
- Truck Rental Fleets
- Diesel Repair Facilities
- Forklift Washing Operations
- Aircraft Maintenance and Restoration
- Shipyards
- Municipalities/State DOTs
- Oil Fields
- Engine Rebuilders and Manufacturers

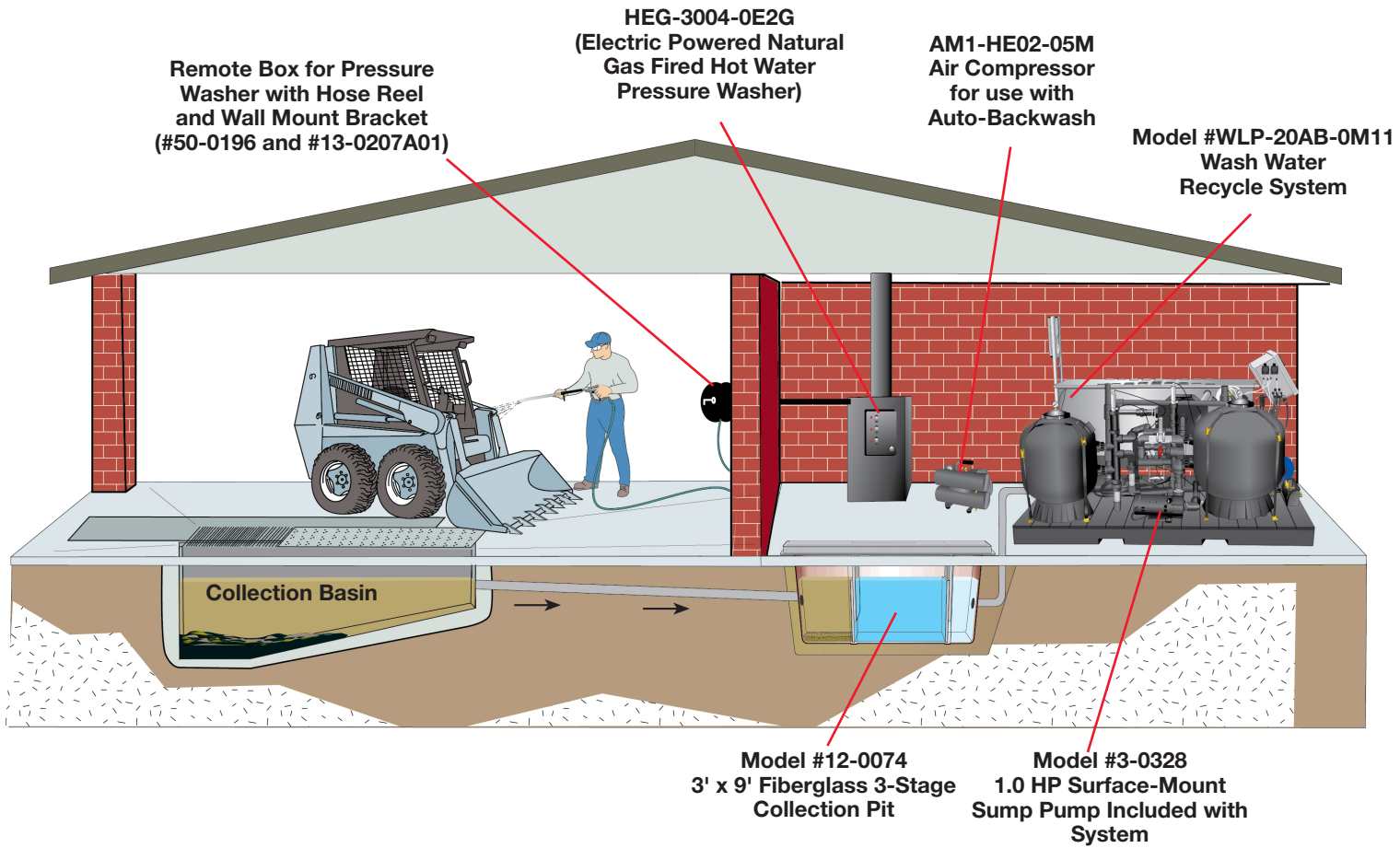

The Importance of a Proper Pit System

Once equipment is washed, the untreated wash water flows into your pit system. A proper pit system for your application is the first step in proper wash water treatment and a critical element in any wash water recycle system.

Consult your dealer to determine the pit system configuration that works best for your application.

Information on fiberglass pits is available in the Pit Systems Brochure.