

NOBLELIFT

**ENTRY LEVEL
STACKER
2200 LBS**

NEW

ADVANTAGES

- Ideal solution for low-duty applications.
- Built-in charger for high autonomy.
- Battery discharge indicator with automatic lift cut-off function for higher battery lifetime.
- 3-points design with centered drive for stability and traction.
- Mono-mast or wide space between masts for perfect view.

PSE 10MSL

NOBLELIFT

Optional straddle leg

Adjustable straddle leg design, suitable for diverse pallet sizes and more stability.

Several masts

2 single mast versions with Monomast design (63inch, 78.7inch lift height) and one 2-stage. Duplexmast with 114 inch, 128inch and 138inch lift height (All with perfect view through the mast). b5= 27inch and straddleleg version optional. (b5=22.4inch standard).

PSE 10LSL



Type sheet for industrial truck acc. to VDI 2198

Distinguishing mark

1.2	Manufacturer's type designation		PSE 22MSL(63)	PSE 22MSL(79)	PSE22LSL(114)	PSE22LSL(126)	PSE22LSL(138)
1.3	Drive		Battery		Battery		
1.4	Operator type		Pedestrian		Pedestrian		
1.5	Load Capacity / rated load	Q (lbs)	2200		2200		
1.6	Load centre distance	C (in)	23.6		23.6		
1.8	Load distance, centre of drive axle to fork	X (in)	28.8		28.5		
1.9	Wheelbase	y (in)	48.3		48.3		

Weight

2.1	Service weight	lbs	1401.4	1430	1588.4	1621.4	1654.4
2.2	Axle loading, laden front/rear	lbs	1139.8/2444.2	1148.4/2464	1289.4/2503.6	1280.4/2525.6	1291.4/2547.6
2.3	Axle loading, unladen front/ rear	lbs	994.4/407	1014.2/415.8	1128.6/481.8	1150.6/470.8	1172.6/481.8

Tires, chassis

3.1	Tires		Polyurethane(PU)		Polyurethane(PU)		
3.2	Tire size, front	φx w (in)	φ7.8x2.9		φ7.8x2.9		
3.3	Tire size, rear	φx w (in)	φ3.3x2.8		φ3.3x2.8		
3.4	Additional wheels (dimensions)	φx w (in)	φ3.1 x 1.2		φ3.1 x 1.2		
3.5	Wheels, number front/ rear(x=driven wheels)		1x+2/2		1x+2/2		
3.6	Tread, front	b10 (in)	19.6		19.6		
3.7	Tread, rear	b11 (in)	42.1-53.9		42.1-53.9		

Dimensions

4.2	Lowered mast height	h1(in)	76.8	82.5	76.8	82.5	88.4
4.3	Free lift height	h2(in)	60.2	76		2.8	
4.4	Lift	h3(in)	60.2	76	111.8	123.8	135.4
4.5	Extended mast height	h4(in)	97.2	113	134.8	148.5	158.3
4.9	Height of tiller in drive position min. / max.	h14(in)	32.5/49.2		32.5/49.2		
4.15	Height, lowered	h13(in)	1.6		1.6		
4.19	Overall length	l1 (in)	71.3		71.3		
4.20	Length to face of forks	l2 (in)	26		26		
4.21	Overall width	b1 (in)	28.6		28.6		
4.22	Fork dimensions	s/e/l (in)	1.4/3.9/45.3		1.4/3.9/45.3		
4.25	Distance between fork-arms	b5 (in)	9.9-31.5		9.9-31.5		
4.32	Ground clearance, centre of wheelbase	m2 (in)	1.6		1.6		
4.33	Aisle width for pallets 1000X1200 crossways	Ast (in)	89.1		88.8		
4.34	Aisle width for pallets 800X1200 lengthways	Ast (in)	87.4		88.8		
4.36	Turning radius	Wa (in)	55.3		55.3		

Performance data

5.1	Travel speed, laden/ unladen	mph	2.3/2.5		2.3/2.5		
5.2	Lift speed, laden/ unladen	fpm	0.02/0.04		0.021/0.029		
5.3	Lowering speed, laden / unladen	fpm	0.03/0.04		0.02/0.02		
5.8	Max. gradeability, laden/unladen	%	5/10		5/10		
5.10	Service brake		Electromagnetic		Electromagnetic		

Electric engine

6.1	Drive motor rating S2 60min	HP	0.6		0.6		
6.2	Lift motor rating at S3 7.5%	HP	2.95		2.95		
6.3	Battery acc. to DIN 43531 /35 / 36 A, B, C, no		no		no		
6.4	Battery voltage, nominal capacity K5	V/Ah	2x12/85		2x12/85		
6.5	Battery weight	lbs	2x55		2x55		
6.6	Energy consumption acc. to VDI cycle	kWh/h	0.65		0.62		

Additional data

8.1	Type of drive control		DC-Speed Controller		DC-Speed Controller		
8.4	Sound level at driver's ear acc. to EN 12053	dB(A)	<70		<70		

PSE 10MSL

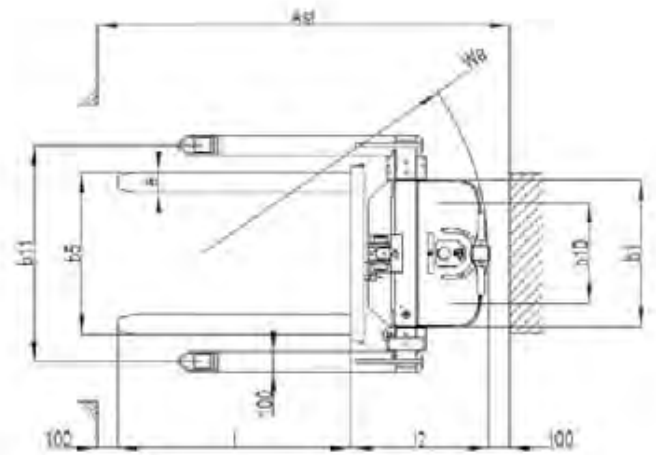
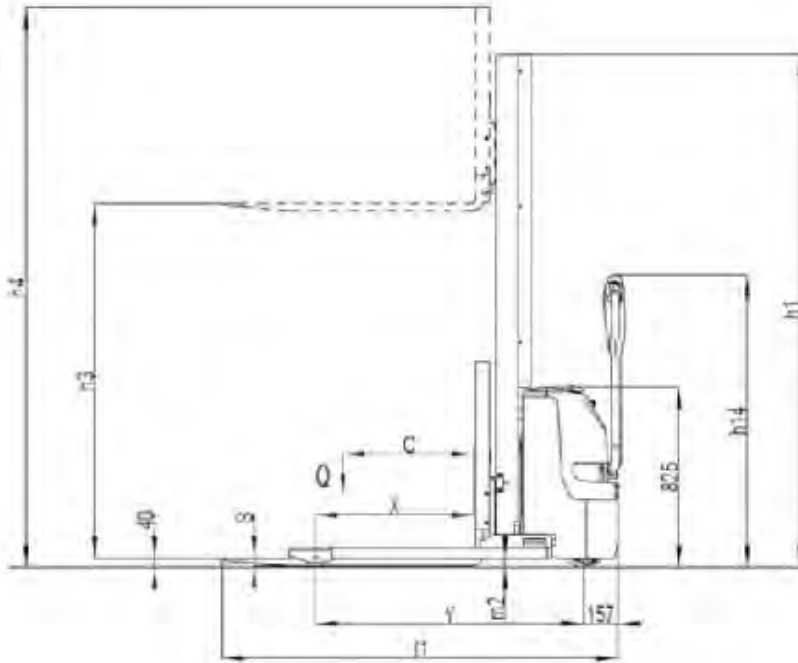

PSE 10LSL

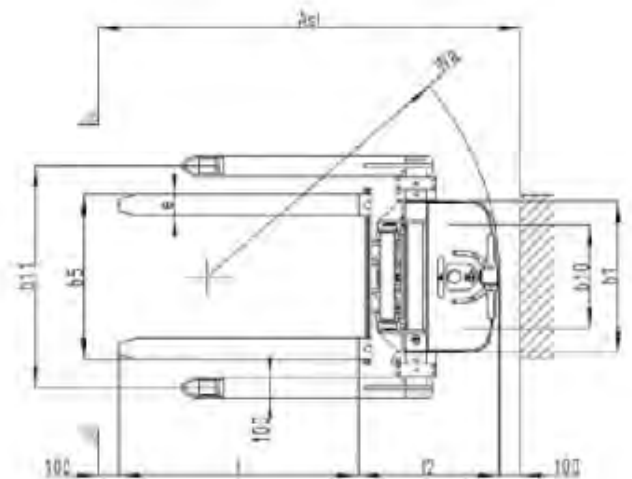
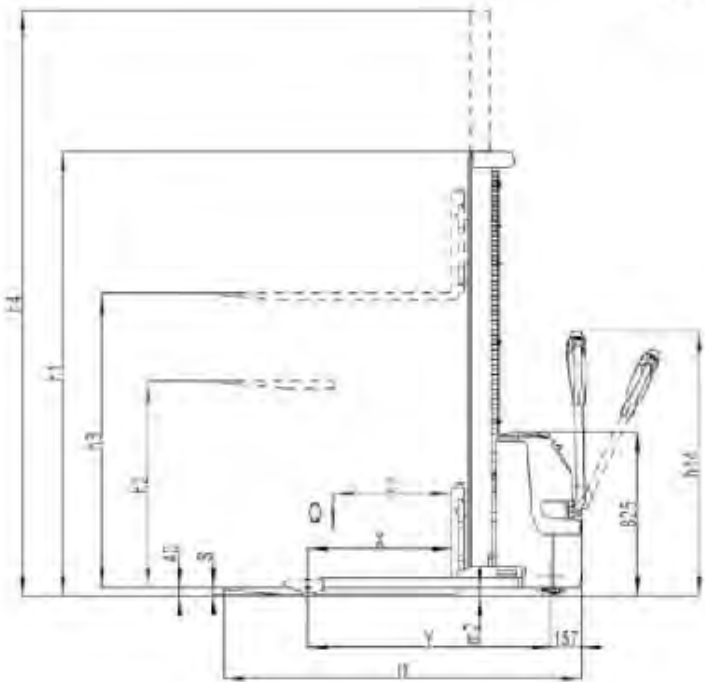



▶ Built-in charger

The built-in charger makes operations more autonomy and increases the operating range.

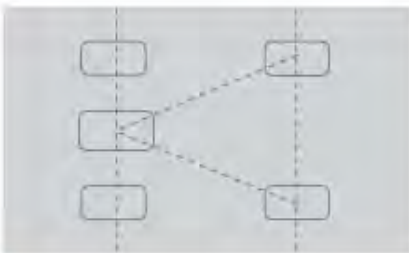

▶ Stability

3-point structure design with centered and drive and 2 stability casters for great stability and traction.



▶ Robust profile

Robust mast with real mast profiles for perfect stability, accuracy and high lifetime.



▶ Powerful battery

2x12V 85Ah powerful main-tenance free batteries (option 2x12V 106Ah).



▶ Battery deep discharge protection

Proofed and ergonomic emergency button and discharge indicator, more robust and reliable than other. The included automatic battery protection ensures high lifetime for the batteries.

▶ Proofed components

Proofed components such as sensors, micro-switches, controller and hydraulic power- pack from international brands.

▶ Fulfilling standards

Fulfilling the actual valid European standards, also in ISO 13849, performance level.

▶ Applications

Ideal economic solution for all indoor low duty and occasional stacking operations.



▶ Economic robust handle

Robust but economic handle with steel housing and plastic coating ensures reliable and comfortable operation.

PSE22M SL PSE22L SL

Entry Level Stacker

INTRODUCTION

The PSE 22 is an economic walkie-electric stacker, with rated capacity of 2200lbs and lifting height from 63inch to 138inch.

The compact and light design is suitable for a variety low duty applications in warehouses.



AUTHORIZED DEALER

Noblelift North America Corp.

Add:2461 S Wolf Road Des Plaines,
IL 60018

Tel:001-847-595-7100

Fax:001-847-595-7200

Email:sales@nobleliftna.com

Http:www.noblelift.us