

NO.	DWG/SUPPLIER	CFG/SUPPLIER NO.	DESCRIPTION	QTY
1	1830-003	CONDUIT 12 x 9	BODY 44RU (77)	1
2	1305020805	7.75"	SPOOL BRACKET	4
3	1305020804	4.5"	SPOOL END PLATE	4
4	1305020806	7.75"	SPOOL	4
5	1305038739	5RU	PLASTIC CABLE MGT FINGERS	16
6	1305038739	3RU	PLASTIC CABLE MGT FINGERS	2

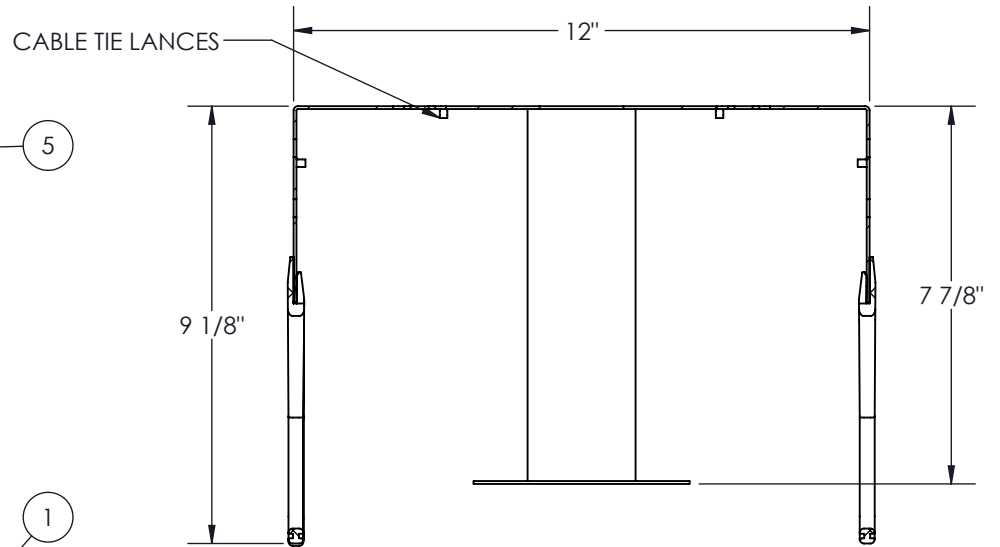

SECTION B-B
SCALE 1 : 4

- NOTES:
 1 - APPROX. WEIGHT: 32.9 LB
 2 - FINISH: TEXTURED POWDER COAT
 3 - FINGERS MADE OF FIRE RETARDANT POLYCARBONATE
 4 - SHIP WITH (12) SETS OF HEX BOLTS 1/4-20 x 3/4

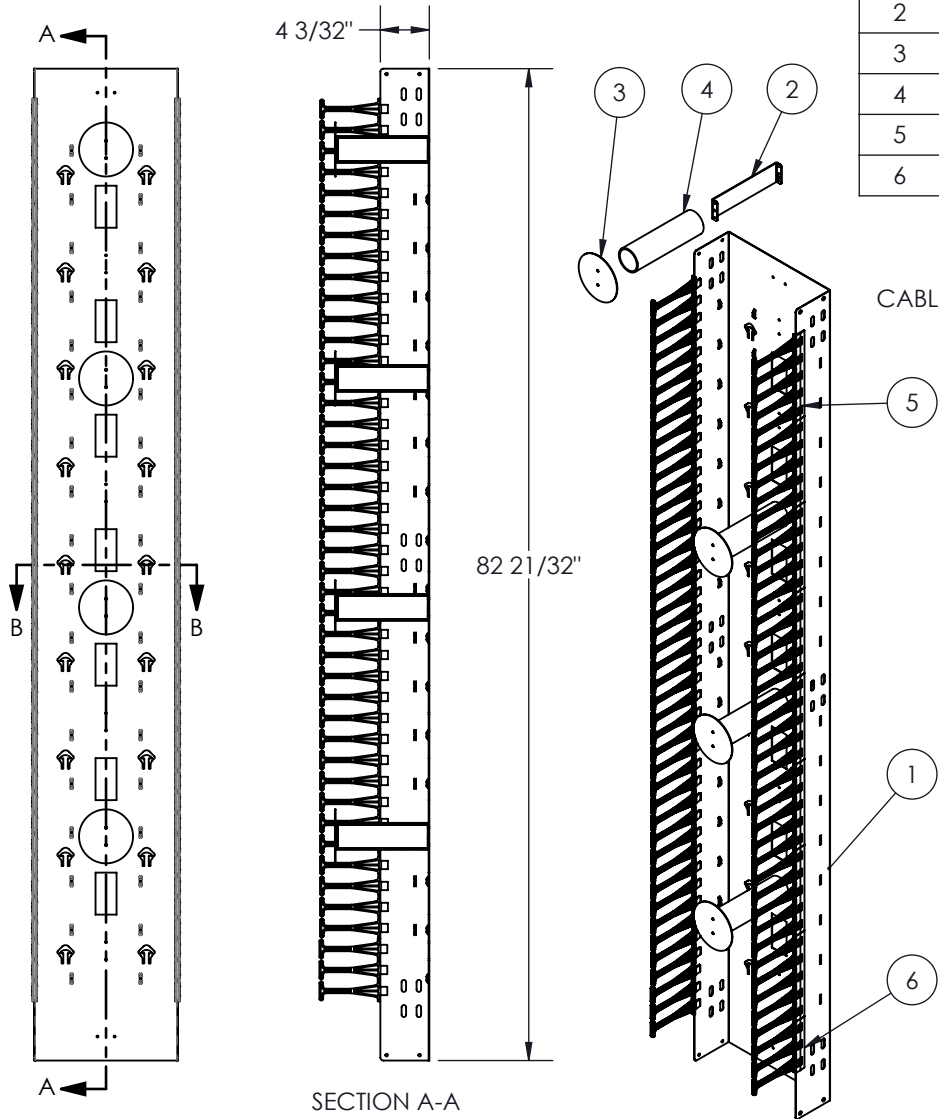

PROPRIETARY AND CONFIDENTIAL
 THE INFORMATION CONTAINED IN THIS DRAWING IS THE SOLE PROPERTY OF ELECTRON METAL A.I.G. INC. ANY REPRODUCTION IN PART OR AS A WHOLE WITHOUT THE WRITTEN PERMISSION OF A.I.G. ELECTRON METAL INC IS PROHIBITED.

APPROVED BY:
T.M.

DRAWN BY: E.D.	Title: HD CABLE MGT 44RU 12 x (77) x 9 WITHOUT DOOR	
CHECKED BY: E.D.		
PROJECT: G:\SWDwgs\CableMgt\CableMgt_Racks\HighDensityPlastic\Simple\Ensembles\	FILE: GestHD12x77x9SansPorte_1830-003_Eng	
PART NO.: CMRHSN-124409	DRAWING NO.: 1830-003	REV.: SCALE: DATE: SHEET:
		1:16 2021-07-19 1 / 1