

NO.	DWG/SUPPLIER	CFG/SUPPLIER NO.	DESCRIPTION	QTY
1	2183-002	8 x 9	BODY 48RU (84)	1
2	1305020805	7.75"	SPOOL BRACKET	4
3	1305020804	3.5"	SPOOL END PLATE	4
4	1305020806	7.75"	SPOOL	4
5	1305038739	5RU	PLASTIC CABLE MGT FINGERS	18
6	1305038739	2RU	PLASTIC CABLE MGT FINGERS	2

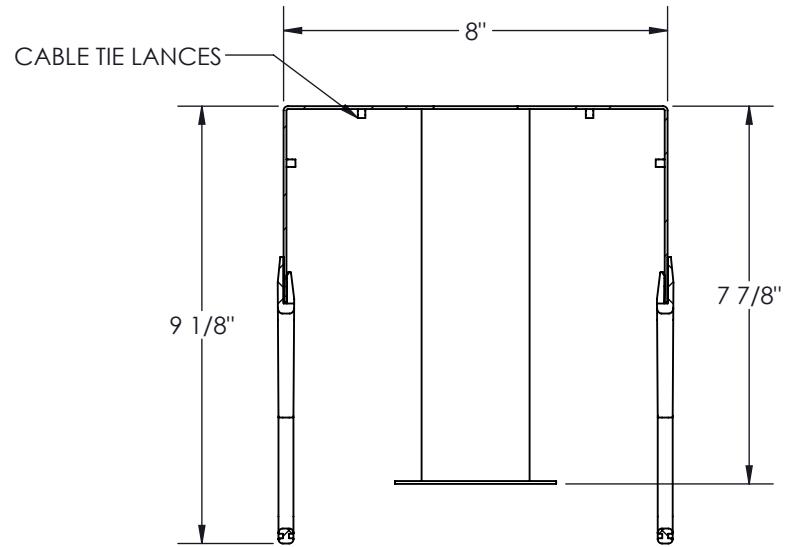

- NOTES:
 1 - APPROX. WEIGHT: 29.5 LB
 2 - FINISH: TEXTURED POWDER COAT
 3 - FINGERS MADE OF FIRE RETARDANT POLYCARBONATE
 4 - SHIP WITH (12) SETS OF HEX BOLTS 1/4-20 x 3/4

Electron METAL PROUDLY MANUFACTURED IN CANADA.

PROPRIETARY AND CONFIDENTIAL
 THE INFORMATION CONTAINED IN THIS DRAWING IS THE SOLE PROPERTY OF ELECTRON METAL A.I.G. INC. ANY REPRODUCTION IN PART OR AS A WHOLE WITHOUT THE WRITTEN PERMISSION OF A.I.G. ELECTRON METAL INC IS PROHIBITED.

APPROVED BY:
E.D.

DRAWN BY:
T.M.

CHECKED BY:
T.M.

Title:
HD CABLE MGT 48RU 8 x (84) x 9 WITHOUT DOOR

PROJECT:
G:\SWDwgs\CableMgt\CableMgt_Racks\HighDensityPlastic\Simple\Ensembles\

FILE:
GestHD8x84x9SansPorte_2191-001_Eng

PART NO.:
CMRHSN-084809

DRAWING NO.:
2191-001

REV.:
A

SCALE:
1:16

DATE:
2018-02-07

SHEET:
1 / 1