

COLOR	PT# SUFFIX
BLACK	-BK
WHITE	-WH
GREY	-GY

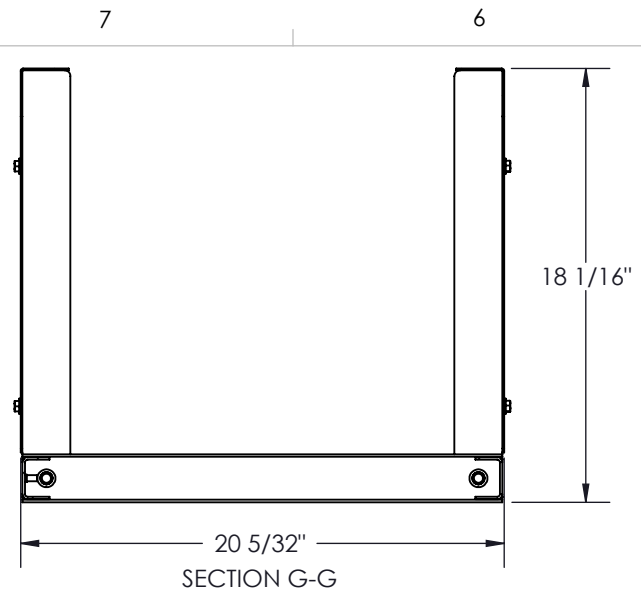

NOTES:

- 1 - APPROX. WEIGHT: 35.70 LBS
- 2 - FINISH: TEXTURED POWDER COATING
- 3 - MATERIAL:
  - 1 - FRAME: STEEL CRS GAUGE 12 ( 0.105")
  - 2 - SIDE: STEEL CRS GAUGE 14 (0.075")
  - 3 - TOP&BOTTOM: STEEL CRS GAUGE 14 (0.075")
- 4 - CONSTRUCT: FRAME FULLY WELDED
- 5 - INCLUDES: ASSEMBLY HARDWARE

NO.	NOTE	DESCRIPTION	QTY
1	156201 - (35) x 18	SIDE, LIGHT DUTY	2
2	1503024147	TOP / BOTTOM ASS'Y (19) x 18	2
3	1305023473	RACK FRAME (19 x 35)	1
4	1/4"	FLAT WASHER 1/4"	8
5	1/4-20 x 5/8	HEX BOLT	8
6	1/2-13 x 1 1/4	HEX BOLT 1/2-13 x 1 1/4	4
7	1540	NYLON BUSHING	4

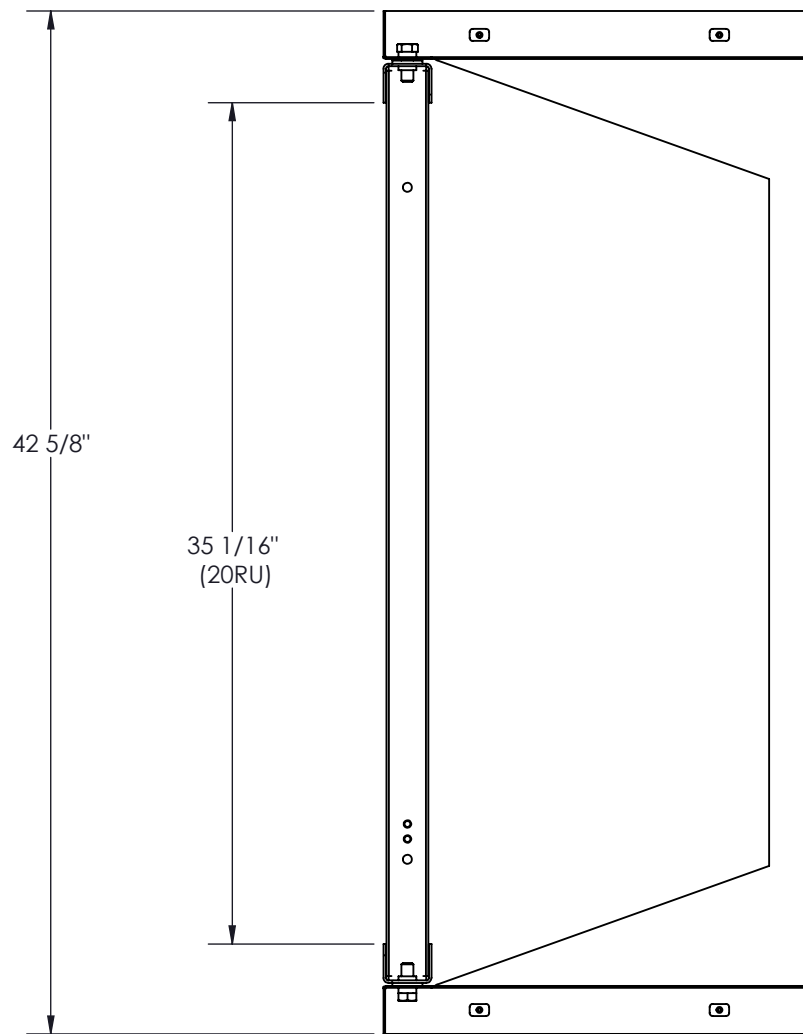
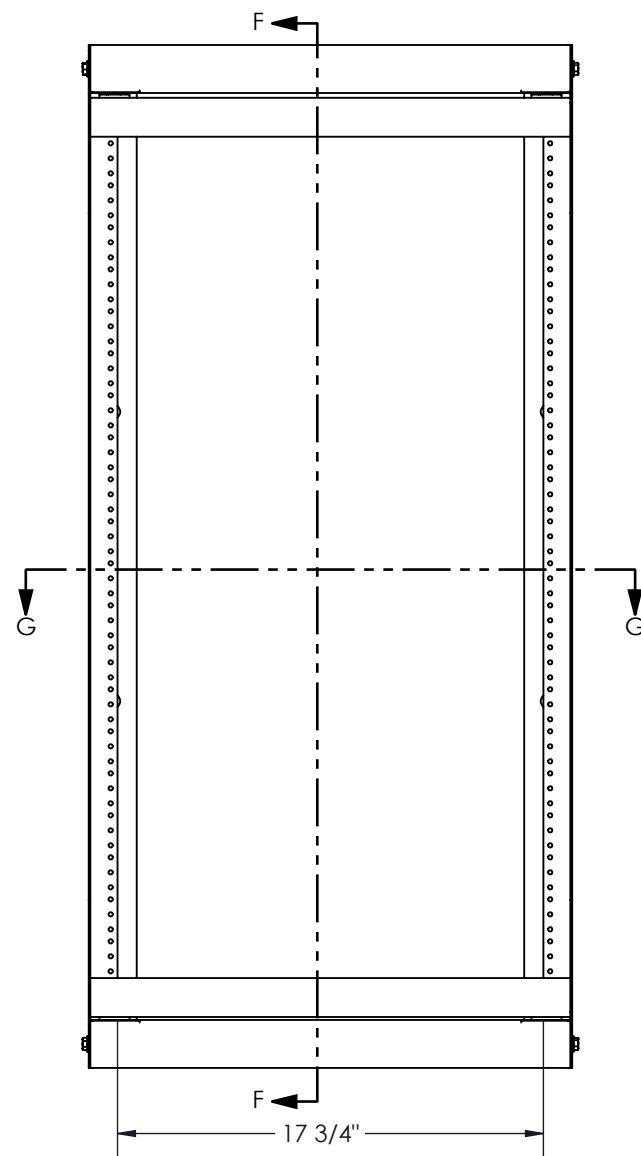

SECTION F-F

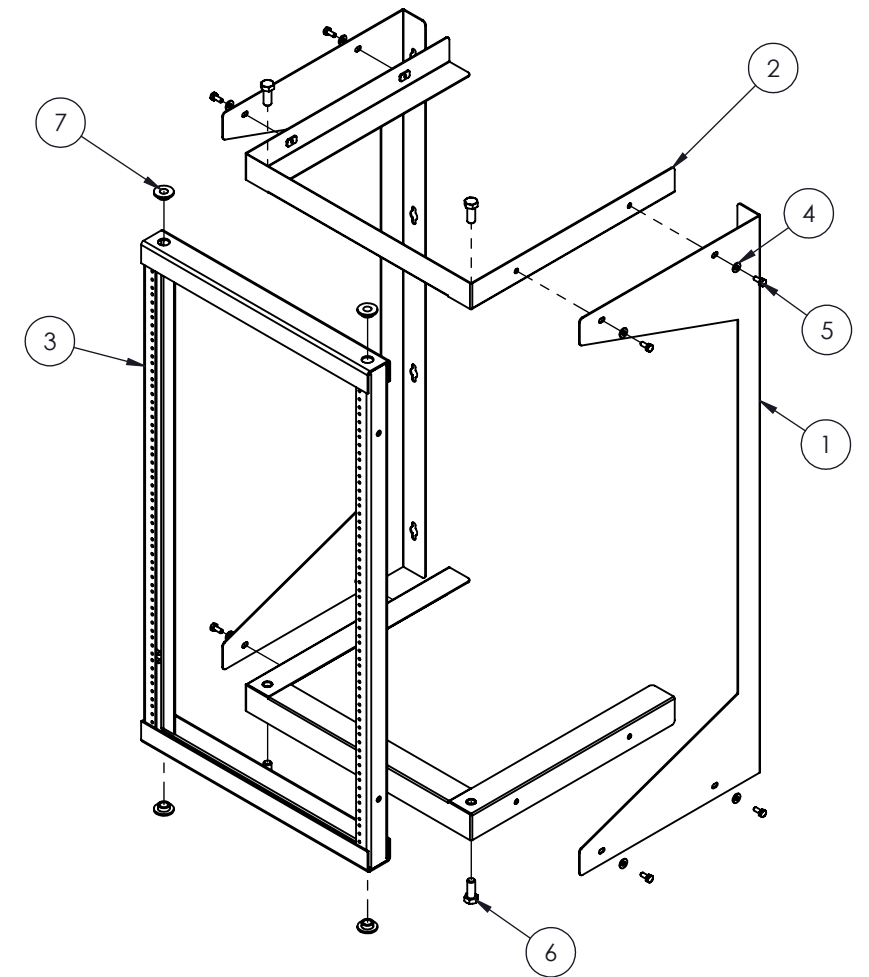

**Electron METAL** PROUDLY MANUFACTURED IN CANADA

CONFIDENTIAL  
 THE INFORMATION CONTAINED IN THIS DRAWING IS THE SOLE PROPERTY OF ELECTRON METAL A.I.G. INC. ANY REPRODUCTION IN PART OR AS A WHOLE WITHOUT THE WRITTEN PERMISSION OF A.I.G. ELECTRON METAL INC IS PROHIBITED.

DRAWN BY: S.DONOFRIO	TITLE: SWING RACK LIGHT DUTY (19 x 35) x 18				
CHECKED BY: E. DUCHESNEAU					
FILE: Leger19x35x18_1305025517_Eng					
PART NO.: WRSSLD-192018	DWG NO.: 1305025517	REV.: -	SCALE: 1:8	DATE: 2008-06-16	SHEET: 1 / 1