

COLOR	PT# SUFFIX
BLACK	-BK
WHITE	-WH
GREY	-GY

NO.	NOTE	DESCRIPTION	QTY
1	1305029684	FRAME (19 x 21)	1
2	1646 - 16"	TOP SUPPORT	2
3	1305029501 - 16"	BOTTOM SUPPORT	2

NOTES:

- 1 - APPROX. WEIGHT: 25.45 LBS
- 2 - FINISH: TEXTURED POWDER COATING
- 3- MATERIAL:
1- FRAME: STEEL CRS GAGUE 12 (0.105")
2- SUPPORT ARMS: STEEL CRS GAGUE 12 (0.105")
- 4 - CONSTRUCT: FRAME FULLY WELDED
- 5 - INCLUDES: ASSMEBLY HARDWARE

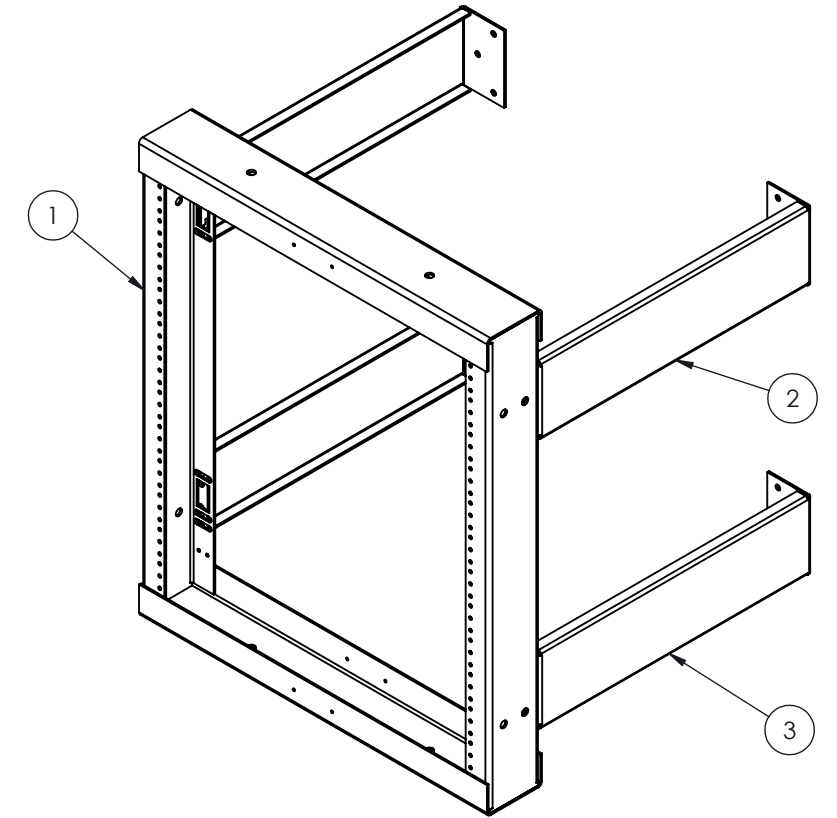
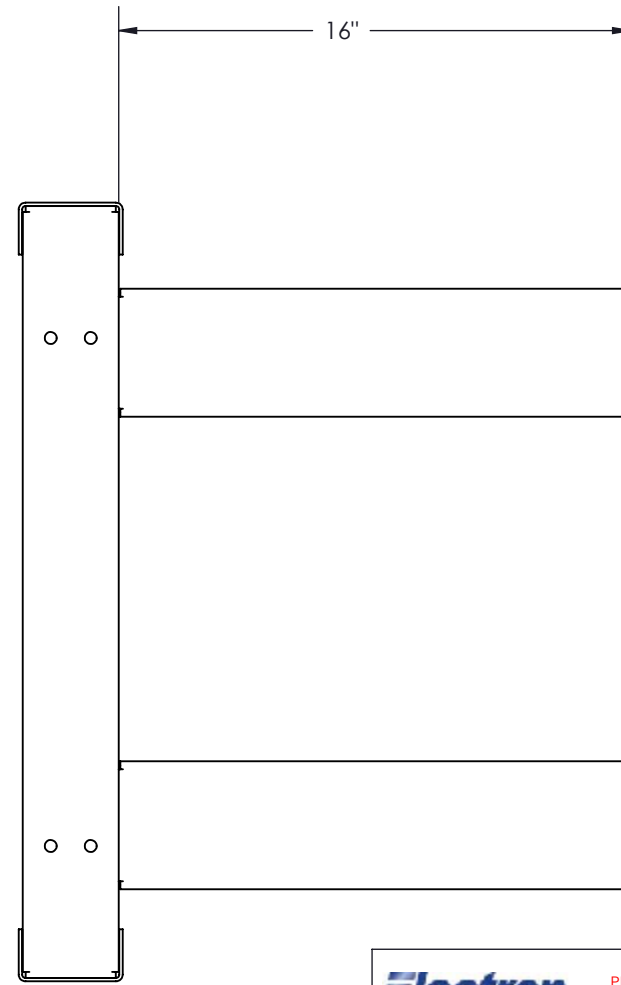
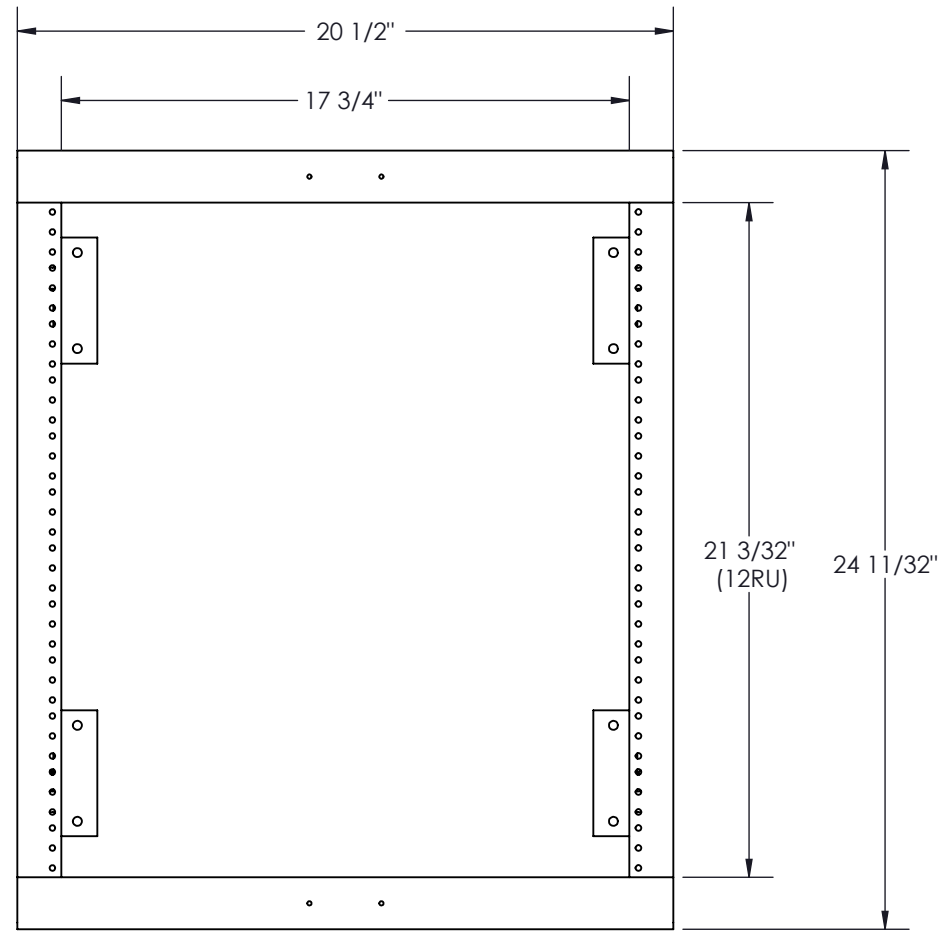
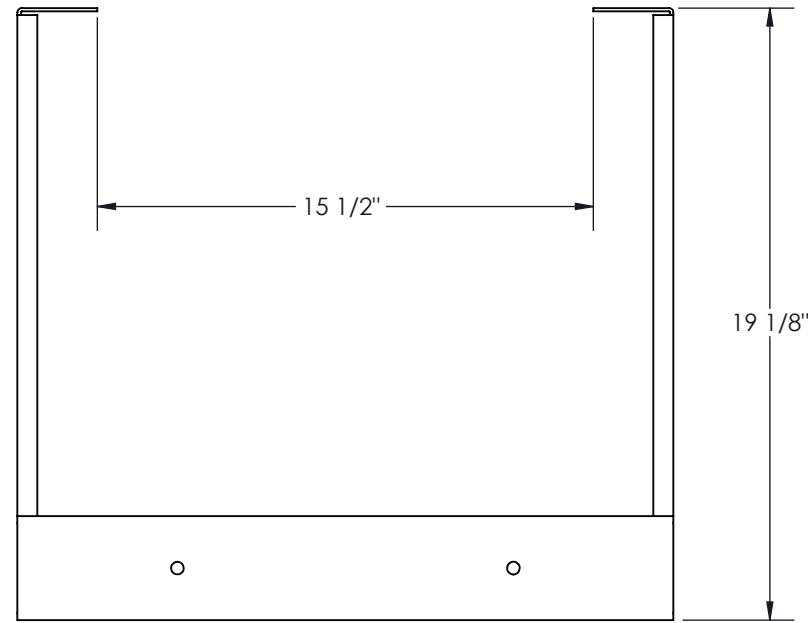

Electron METAL PROUDLY MANUFACTURED IN CANADA

CONFIDENTIAL
THE INFORMATION CONTAINED IN THIS DRAWING IS THE SOLE PROPERTY OF ELECTRON METAL A.I.G. INC. ANY REPRODUCTION IN PART OR AS A WHOLE WITHOUT THE WRITTEN PERMISSION OF A.I.G. ELECTRON METAL INC IS PROHIBITED.

DRAWN BY: E.D.	TITLE: WALL MOUNT RACK (19 x 21) x 16			
CHECKED BY: E.D.	FILE: RackMural19x21x16_1305023432_Eng			
PART NO.: WMRFIX-191216	DWG NO.: 1305023432	REV.: A	SCALE: 1:6	DATE: 2006-06-14
APPROVED BY:				SHEET: 1 / 1