

NO.	NOTE	DESCRIPTION	QTÉ
1	1730-002	BATI 22 x 18 x 18	1
2	1730-005	SECTION ARRIÈRE (19 x 15.75)	1
3	1305037382 - (15.75) x 17.875	PANNEAU LATÉRAL	2
4	1305037380	PORTE PLEXI (19 x 15)	1
5	1305026886 - TROU .354, DÉCALAGE .094	CAME SIMPLE	2
6	1305021797 - (15.75")	RAIL DE MONTAGE CAGE-NUTS 1.25"	2
7	SOUTHCO 96-10-520-50	CHARNIÈRE DÉCALÉE, LARGE GAUCHE (B)	2
8	SOUTHCO K4-2338-07	CROCHET POUR FERMOIR	1
9	SOUTHCO K4-2833-07	FERMOIRE "LINK ROTARY", MÉDIUM	1
10	ILCO D35803UZ-01018 (#549)	SERRURE COURTE	2

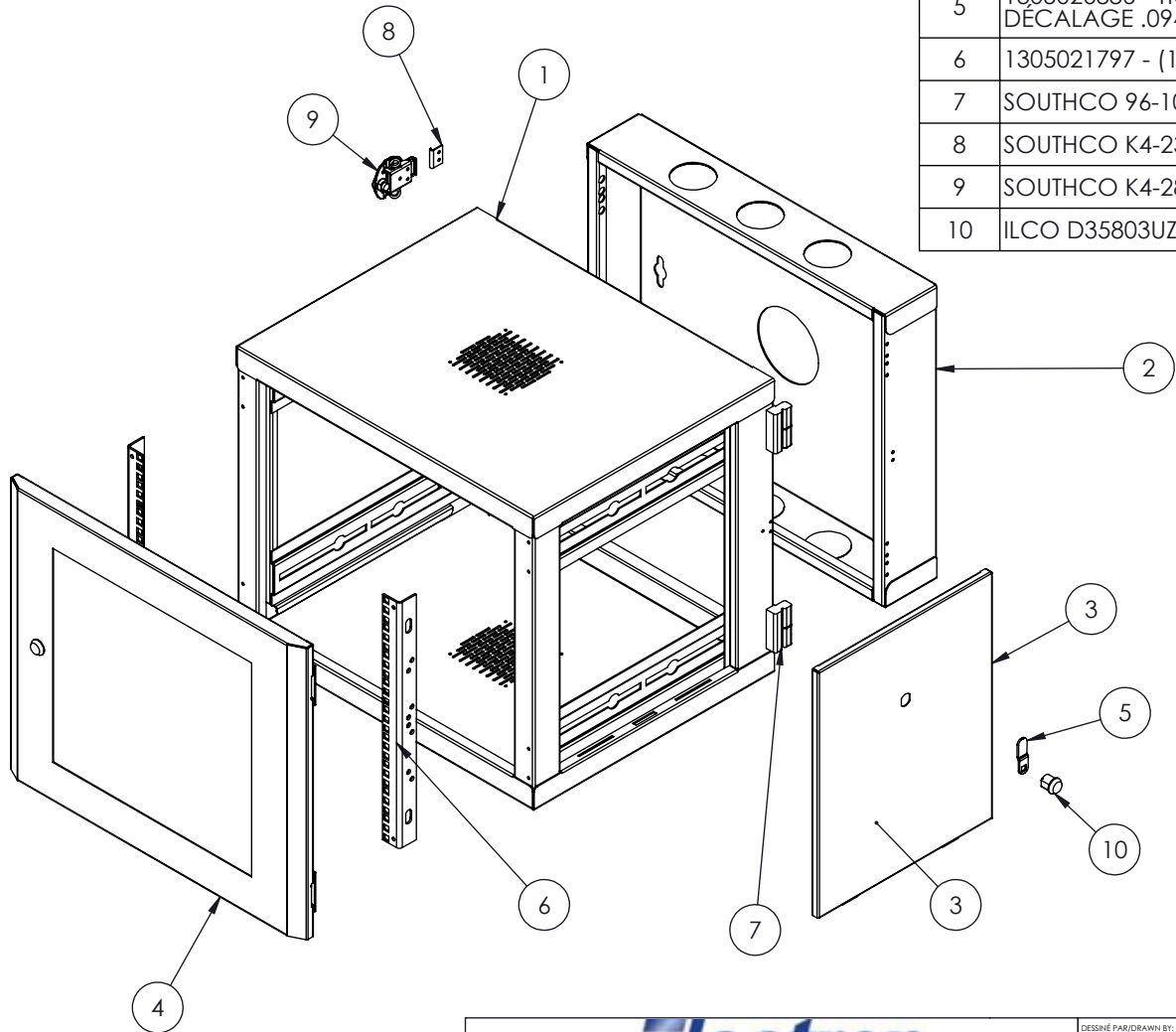

NOTES:

1 - CHARGE MAXIMALE: 150 LB

<p>PROUDLY MANUFACTURED IN CANADA.</p> <p>FABRIQUÉ AVEC FIERTÉ AU QUÉBEC.</p>	<p>DESSINÉ PAR/DRAWN BY: E.D.</p>	<p>Title/Titre: CABINET MURAL 9RU (19 x 15.75) x 22</p>			
	<p>VÉRIFIÉ PAR/CHECKED BY: E.D.</p>				
<p>PROPRIETARY AND CONFIDENTIAL THE INFORMATION CONTAINED IN THIS DRAWING IS THE SOLE PROPERTY OF A.I.G. ELECTRON METAL INC. ANY REPRODUCTION IN PART OR AS A WHOLE WITHOUT THE WRITTEN PERMISSION OF A.I.G. ELECTRON METAL INC IS PROHIBITED.</p>	<p>CONFIDENTIEL L'INFORMATION CONTENUE DANS CE DESSIN EST L'ENTIÈRE PROPRIÉTÉ D'ELECTRON METAL A.I.G. INC. TOUTE REPRODUCTION PARTIELLE OU EXHAUSTIVE SANS PERMISSION ÉCRITE D'ELECTRON METAL A.I.G. INC. EST INTERDITE.</p>	<p>PROJET/PROJECT: G:\SWDwgs\WallMount\Cabinet2013\Ensembles\</p>		<p>FICHER/FILE: Cabinet19x15x22_2186-001</p>	
		<p>NO. DE PIÈCE/PART NO.: WMCRE1-190922</p>	<p>NO. DE DESSIN/DRAWING NO.: 2186-001</p>	<p>RÉV./REV.: </p>	<p>ÉCHELLE/SCALE: 1:10</p>

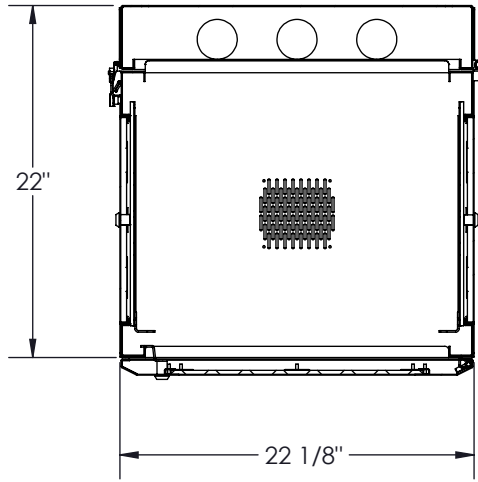

COUPE D-D

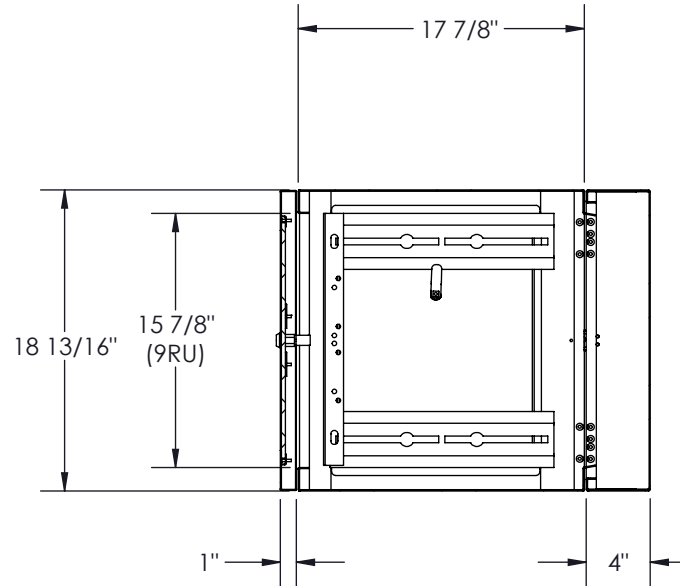
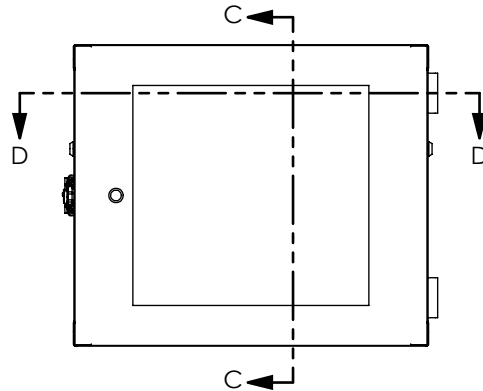

COUPE C-C

PROUDLY
MANUFACTURED
IN CANADA.



FABRIQUÉ
AVEC FIERTÉ
AU QUÉBEC.

PROPRIETARY AND CONFIDENTIAL
THE INFORMATION CONTAINED IN THIS
DRAWING IS THE SOLE PROPERTY OF
A.I.G. ELECTRON METAL INC. ANY
REPRODUCTION IN PART OR AS A WHOLE
WITHOUT THE WRITTEN PERMISSION OF
A.I.G. ELECTRON METAL INC IS PROHIBITED.

CONFIDENTIEL
L'INFORMATION CONTENUE DANS
CE DESSIN EST L'ENTÈRE PROPRIÉTÉ
D'ELECTRON METAL A.I.G. INC. TOUTE
REPRODUCTION PARTIELLE OU EXHAU-
STIVE SANS PERMISSION ÉCRITE D'ELEC-
TRON METAL A.I.G. INC. EST INTERDITE.

DESSINÉ PAR/DRAWN BY:

E.D.

VÉRIFIÉ PAR/CHECKED BY:

E.D.

Title/Titre:

CABINET MURAL 9RU (19 x 15.75) x 22

PROJET/PROJECT:

G:\SWDwgs\WallMount\Cabinet2013\Ensembles\

FICHER/FILE:

Cabinet19x15x22_2186-001

NO. DE PIÈCE/PART NO.:

WMCRE1-190922

NO. DE DESSIN/DRAWING NO.:

2186-001

RÉV./REV.:

ÉCHELLE/SCALE:

1:12

DATE:

2018-02-05

PAGE/SHEET:

2 / 2