

COLOR	PT# SUFFIX
BLACK	-BK
WHITE	-WH
GREY	-GY

NO.	NOTE	DESCRIPTION	QTY
1	1305033082	FRAME 28 x 24 x 18	1
2	2284-006 - (21")	REINFORCED MOUNTING RAIL TAPPED 4.25" FOR BRUSH	2
3	1832-005	HIGH DENSITY RAIL CABLE MGT (21")	2
4	1305033085	PLEXI. DOOR (25 X 21)	1
5	2658-016	REAR SECTION 12RU (25 x 21) x 10	1
6	1515	4" FAN CUTOUT COVER PLATE	8
7	1305037411	FRONT FEMALE HINGE	2
8	1305037410	REAR MALE HINGE	2
9	8-32 x 1/2	THREAD ROLLING PAN HEAD - PHILLIPS	10
10	10-32 x 3/8	PAN HEAD SCREW 10-32 x 3/8 COMBO	8
11	SOUTHCO K4-2338-07	KEEPER	2
12	SOUTHCO K4-2833-07	LINK ROTARY LATCH, MEDIUM	2
13	97245A673	CLEVIS PIN 3/8 x 3/4	2

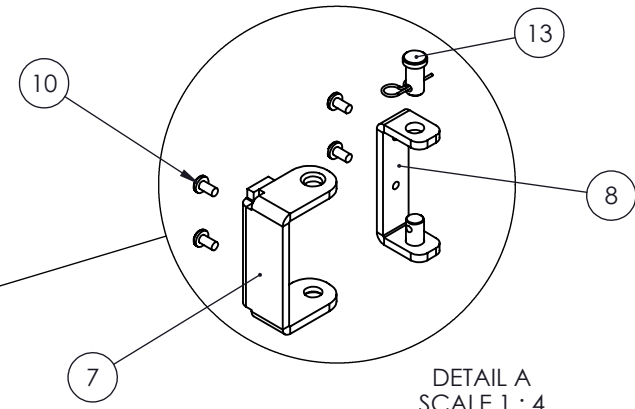
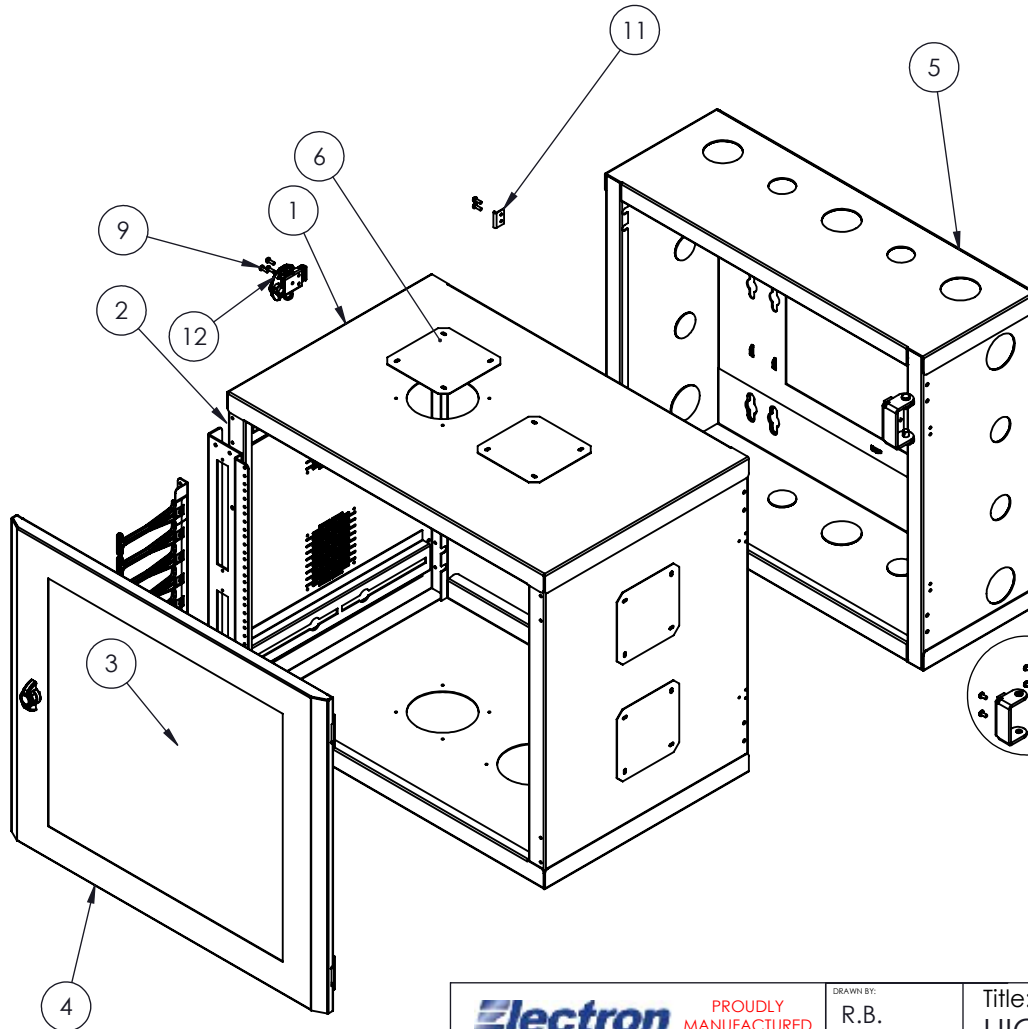

DETAIL A
SCALE 1 : 4

NOTES:
 1 - CAPACITY: 150 LB
 2 - WEIGHT: 122 LB
 3 - FINISH : TEXTURED POWDER COAT.



PROPRIETARY AND CONFIDENTIAL
 THE INFORMATION CONTAINED IN THIS DRAWING IS THE SOLE PROPERTY OF ELECTRON METAL A.I.G. INC. ANY REPRODUCTION IN PART OR AS A WHOLE WITHOUT THE WRITTEN PERMISSION OF A.I.G. ELECTRON METAL INC IS PROHIBITED.

APPROVED BY:
 E.D.

DRAWN BY: R.B.	Title: HIGH DENSITY WALL MNT CABINET 12RU (25 x 21) x 28 28 x 24 x 28	FILE: CabinetHD25x21x28_3058-001_Eng	
CHECKED BY: R.B.		PROJECT: G:\SWDwgs\WallMount\Cabinet2013\EnsemblesHauteDensite\	
PART NO: WMCRCH-251228	DRAWING NO: 3058-001	REV.: A	SCALE: 1:12
		DATE: 2020-11-03	SHEET: 1 / 2

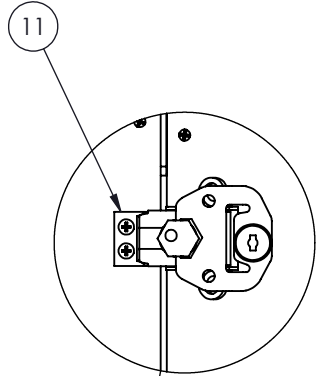

DETAIL E
SCALE 1 : 4

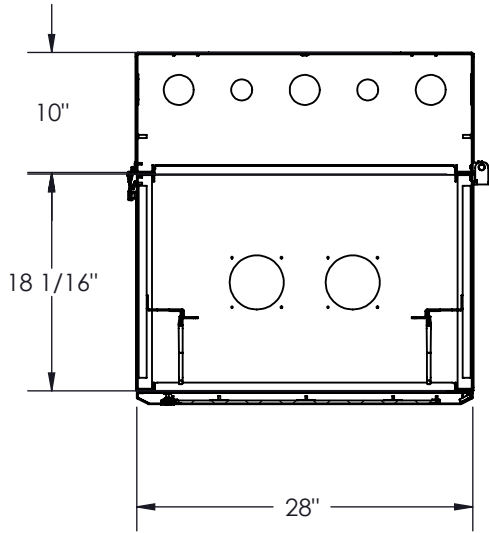

SECTION C-C

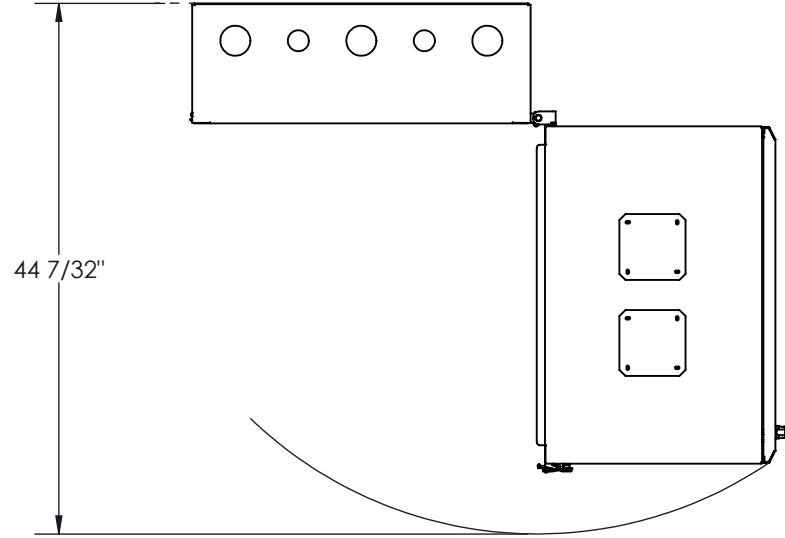

TOP VIEW
REQUIRED CLEARANCE

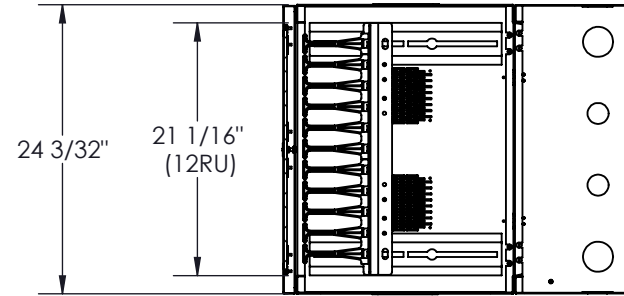
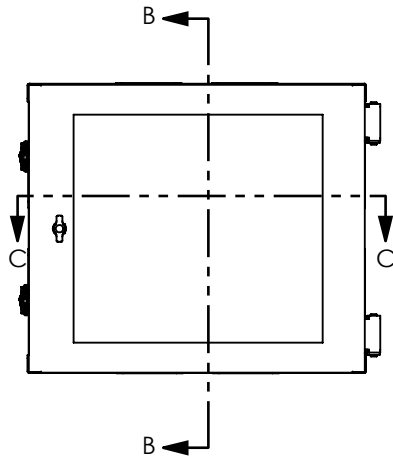
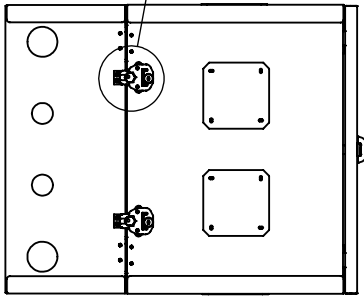

SECTION B-B

Electron METAL PROUDLY MANUFACTURED IN CANADA.

PROPRIETARY AND CONFIDENTIAL
THE INFORMATION CONTAINED IN THIS DRAWING IS THE SOLE PROPERTY OF ELECTRON METAL A.I.G. INC. ANY REPRODUCTION IN PART OR AS A WHOLE WITHOUT THE WRITTEN PERMISSION OF A.I.G. ELECTRON METAL INC IS PROHIBITED.

APPROVED BY:
E.D.

DRAWN BY:
R.B.
CHECKED BY:
R.B.

Title:
HIGH DENSITY WALL MNT CABINET 12RU (25 x 21) x 28
28 x 24 x 28

PROJECT:
G:\SWDwgs\WallMount\Cabinet2013\EnsemblesHauteDensite\

FILE:
CabinetHD25x21x28_3058-001_Eng

PART NO.:
WMCRCH-251228

DRAWING NO.:
3058-001

REV.:
A

SCALE:
1:16

DATE:
2020-11-03

SHEET:
2 / 2