

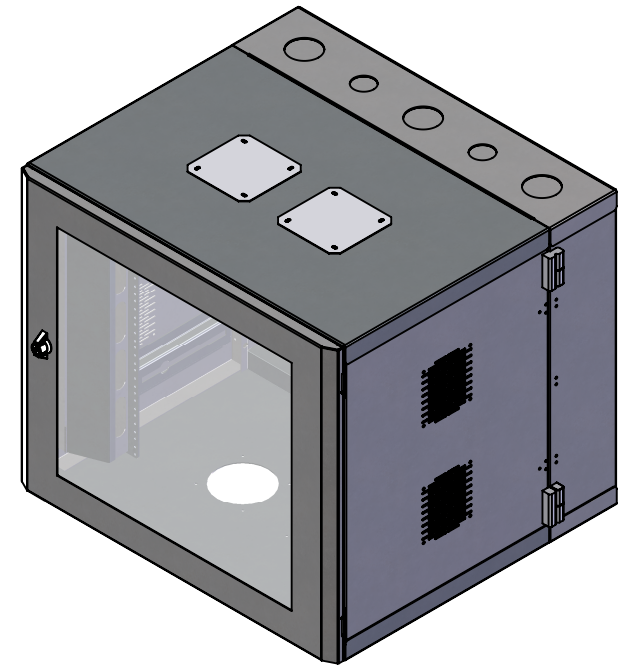

RÉV.	DESCRIPTION	DATE	APPR.
RÉVISIONS			

NO.	DESCRIPTION	QTY
1	FRAME 28 x 24 x 18	1
2	REAR SECTION (25 x 21)	1
3	RAIL 4.25" CUTOUTS TAPPED 10-32	2
4	VERTICAL CABLE MGT 3.5 x 3 x 21	2
5	PLEXIGLAS DOOR (25 x 21)	1
6	4" FAN CUTOUT COVER PLATE	2
7	LINK ROTARY LATCH, MEDIUM	2
8	KEEPER	2
9	OFFSET HINGE, LARGE, LH	1
10	OFFSET HINGE, LARGE, RH	1

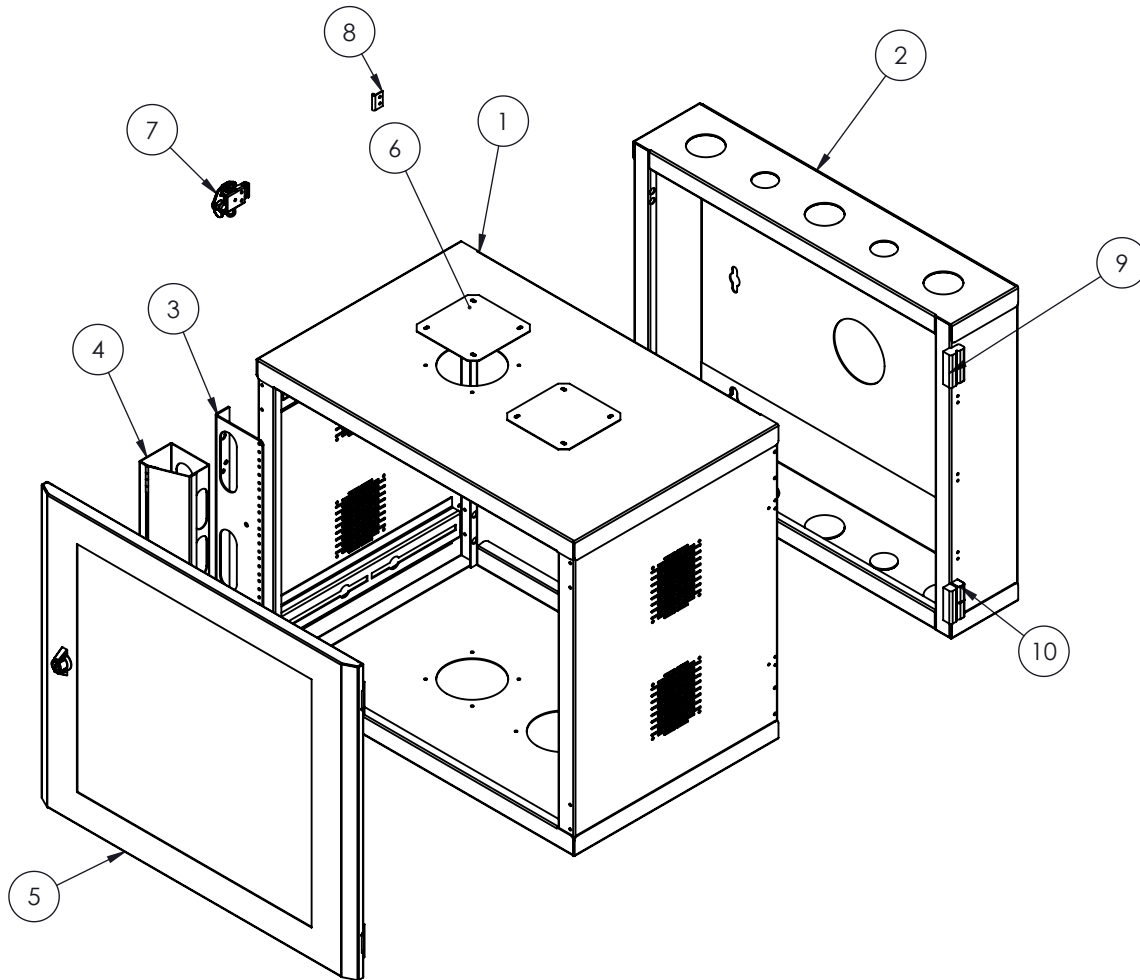



NOTES:

- 1 - CAPACITY: 150 LB
- 2 - WEIGHT: 120 LB
- 3 - CABINET IS FULLY REVERSIBLE LH OR RH SWING.

  
**PROPRIETARY AND CONFIDENTIAL**  
 THE INFORMATION CONTAINED IN THIS DRAWING IS THE SOLE PROPERTY OF A.I.G. ELECTRON METAL INC. ANY REPRODUCTION IN PART OR AS A WHOLE WITHOUT THE WRITTEN PERMISSION OF A.I.G. ELECTRON METAL INC IS PROHIBITED.

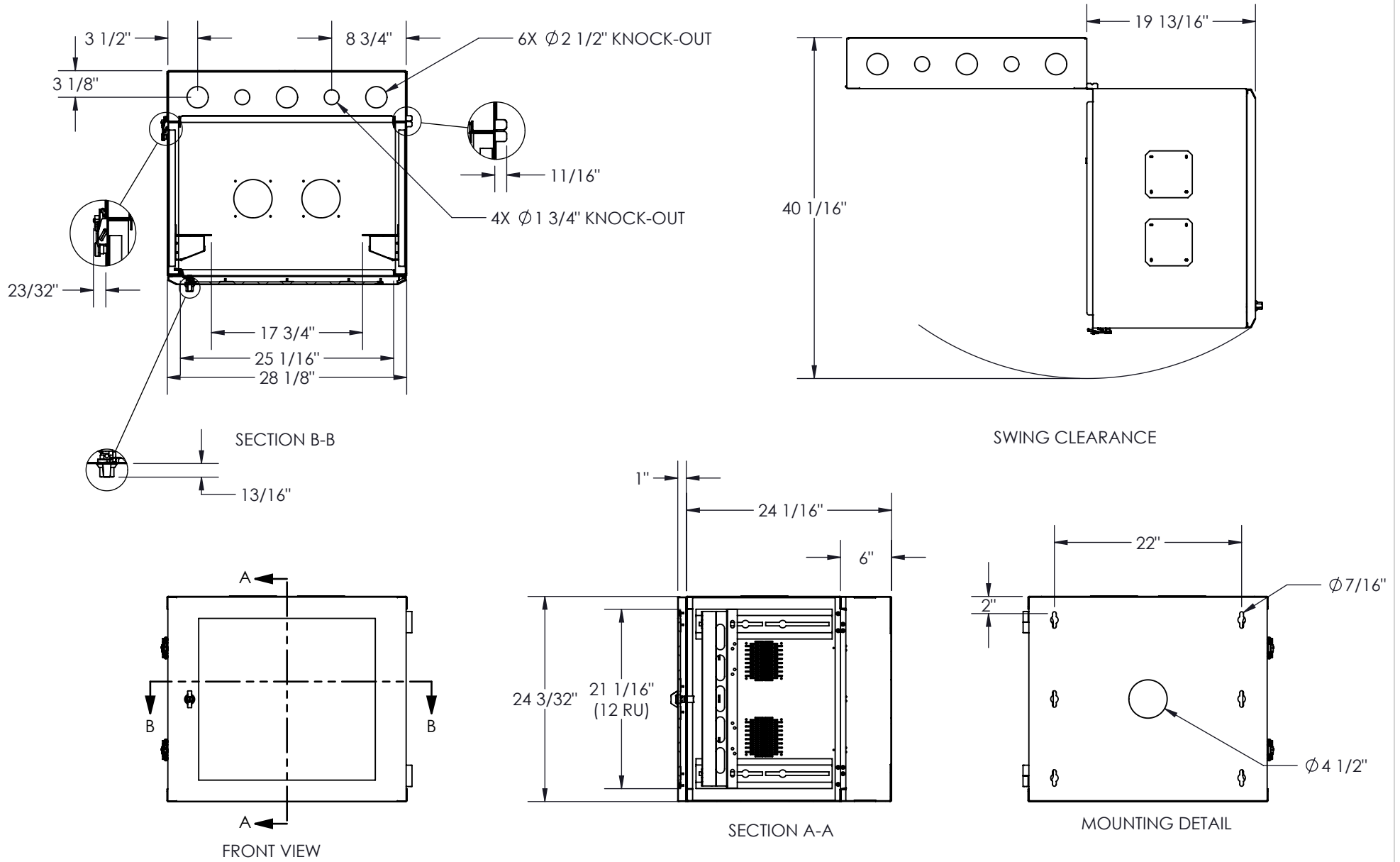
DRAWN BY: S.B.		Title: WALL MOUNT CABINET (25 x 21) x 24 REVERSED			
CHECKED BY: S.B.		PROJECT: WallMount\Cabinet2013\Ensembles		FILE: Cabinet25x21x24_1305033084_Eng	
PART NO.:	DRAWING NO.:	REV.:	SCALE:	DATE:	SHEET:
WMCRC1-251224	1305031354	-	1:12	2013-07-31	1 / 2



 <p><b>PROPRIETARY AND CONFIDENTIAL</b> THE INFORMATION CONTAINED IN THIS DRAWING IS THE SOLE PROPERTY OF A.I.G. ELECTRON METAL INC. ANY REPRODUCTION IN PART OR AS A WHOLE WITHOUT THE WRITTEN PERMISSION OF A.I.G. ELECTRON METAL INC IS PROHIBITED.</p>	DRAWN BY: S.B.	Title: WALL MOUNT CABINET (25 x 21) x 24 REVERSED				
	CHECKED BY: S.B.	PROJECT: WallMount\Cabinet2013\Ensembles		FILE: Cabinet25x21x24_1305033084_Eng		
	PART NO.: WMCRC1-251224	DRAWING NO.: 1305031354	REV.: -	SCALE: 1:16	DATE: 2013-07-31	SHEET: 2 / 2