

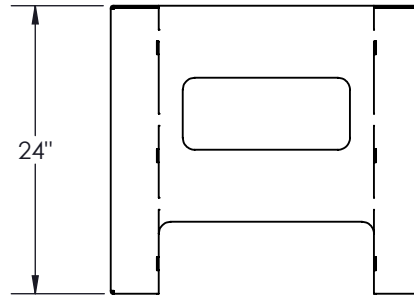

COLOR	PT# SUFFIX
BLACK	-BK
WHITE	-WH
GREY	-GY

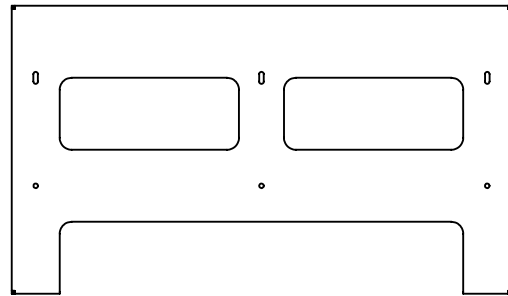
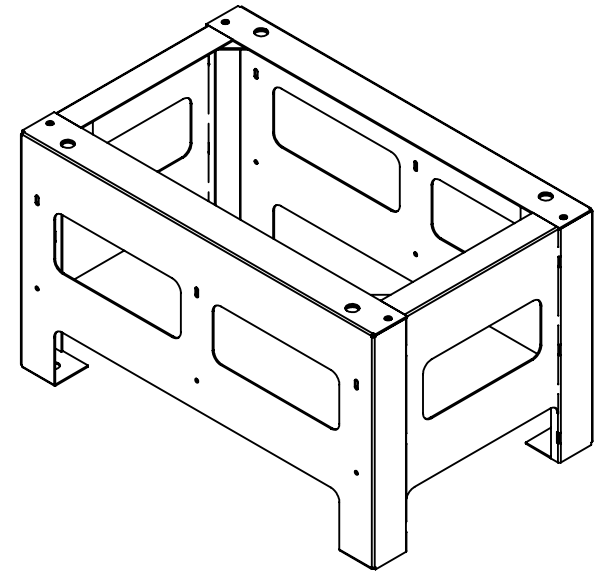
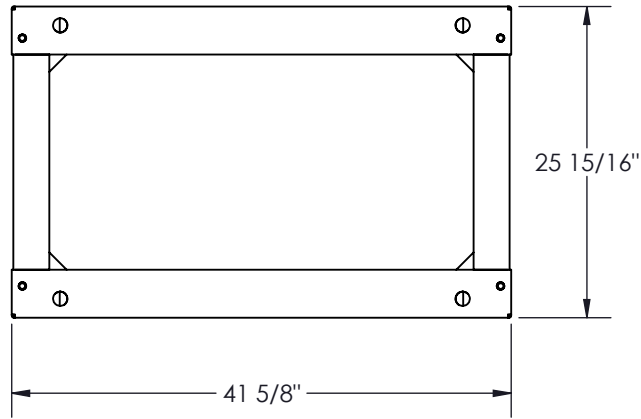

NOTES:

- 1 - SEISMIC CAPACITY 1400 LB.
- 2 - CERTIFIED TO ASCE 7-10 (STANDARD INSTALLATIONS)
- 3 - APPROX. WEIGHT: 107 LB.
- 4 - MAT'L: 10 GA (.135") CRS
- 5 - FINISH: POLYESTER POWDER COAT.
- 6 - CONSTRUCTION: FULLY WELDED

REV.	DESCRIPTION	DATE	APPR.
REVISIONS			

 PROUDLY MANUFACTURED IN CANADA.	DRAWN BY: E.D.	Title: SEISMIC PEDESTAL 26 x 24 x 42			
	CHECKED BY: E.D.				
PROPRIETARY AND CONFIDENTIAL THE INFORMATION CONTAINED IN THIS DRAWING IS THE SOLE PROPERTY OF A.I.G. ELECTRON METAL INC. ANY REPRODUCTION IN PART OR AS A WHOLE WITHOUT THE WRITTEN PERMISSION OF A.I.G. ELECTRON METAL INC IS PROHIBITED.	PROJECT:	FILE: SeismicPedestal30x24x42_2207-001_Eng			
	PART NO.: PEDZO4-262442	DRAWING NO.: 2203-001	REV.: -	SCALE: 1:16	DATE: 2018-02-08