

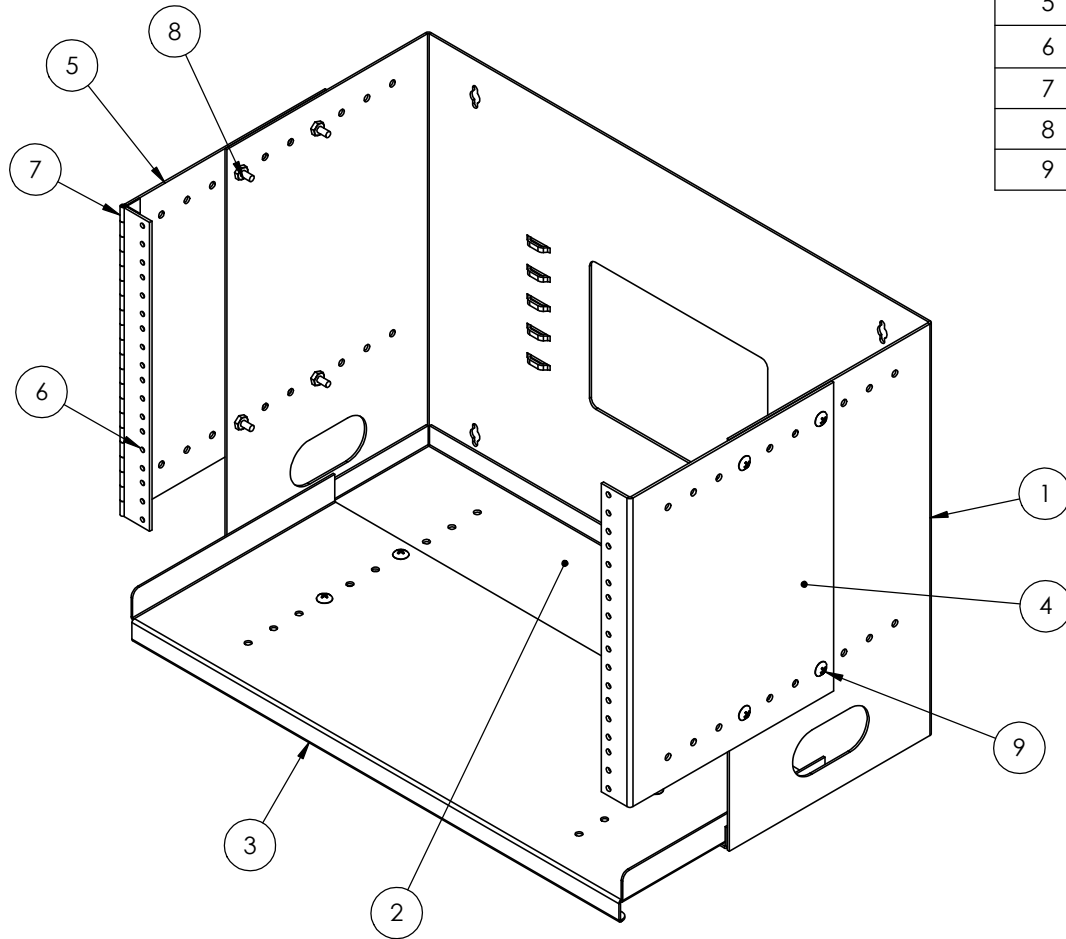

NO.	NOTE	DESCRIPTION	QTY
1	1305026008	BODY, HUB SHELF	1
2	1305022117	BASE, HUB SHELF	1
3	1305022035	SHELF, HUB SHELF	1
4	124202 - (10.5")	FIXED SIDE, AJUST. WALL MNT. BRACKET	1
5	124203 - (10.5")	AJUST. BRACKET HINGE SIDE, 16" DEEP	1
6	1305022024 - (10.5")	RAIL, ADJ. WALL BRACKET	1
7	-	PIANO HINGE ASS'Y 7"	1
8	10-32	HEX NUT	12
9	10-32 x 5/8	TRUSS HEAD SCREW	12



 <p>PROPRIETARY AND CONFIDENTIAL THE INFORMATION CONTAINED IN THIS DRAWING IS THE SOLE PROPERTY OF A.I.G. ELECTRON METAL INC. ANY REPRODUCTION IN PART OR AS A WHOLE WITHOUT THE WRITTEN PERMISSION OF A.I.G. ELECTRON METAL INC IS PROHIBITED.</p> <p>CONFIDENTIEL L'INFORMATION CONTENUE DANS CE DESSIN EST L'ENTIERE PROPRIÉTÉ D'ELECTRON METAL A.I.G. INC. TOUTE REPRODUCTION PARTIELLE OU EXHAUSTIVE SANS PERMISSION ÉCRITE D'ELECTRON METAL A.I.G. INC. EST INTERDITE.</p>		DESSINÉ PAR/DRAWN BY:		Title/Titre:	
		VERIFIÉ PAR/CHECKED BY:		ADJ. HUB SHELF ASS'Y 19 x 10.5	
PROJET/PROJECT:			FICHER/FILE:		REV./REV.:
HubShelf_6U			HubShelfAssy_1305026007_WebSite		-
NO. DE PIÈCE/PART NO.:	NO. DE DESSIN/DRAWING NO.:	ECHELLE/SCALE:	DATE:	PAGE/SHEET:	
WMB-0020027-002	1305026007	1:5.33333	2008-10-08	1 / 2	

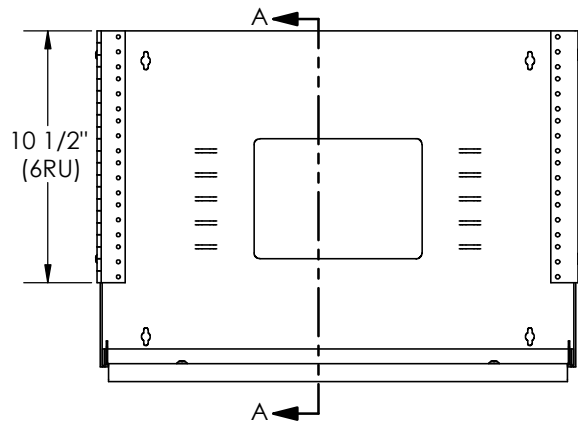
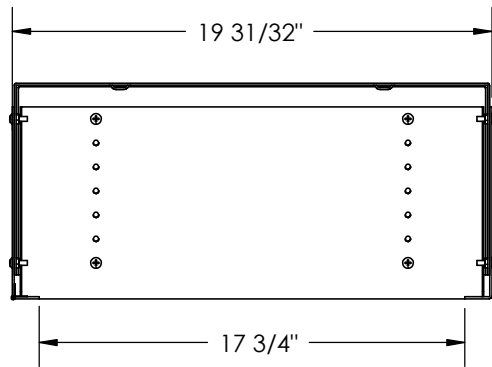

FRONT VIEW

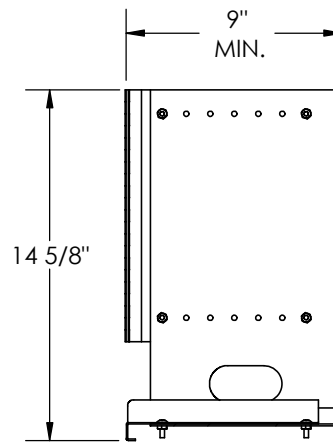

SECTION A-A
9" DEEP

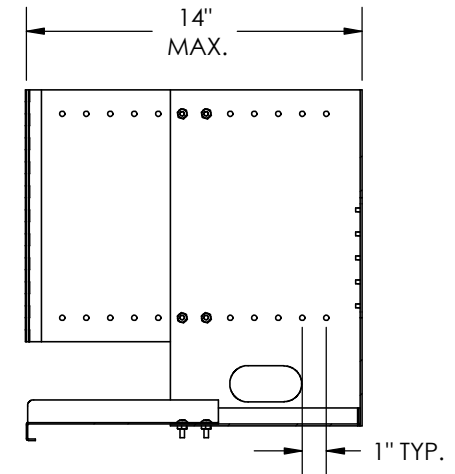

SECTION A-A
14" DEEP



PROPRIETARY AND CONFIDENTIAL
THE INFORMATION CONTAINED IN THIS DRAWING IS THE SOLE PROPERTY OF A.I.G. ELECTRON METAL INC. ANY REPRODUCTION IN PART OR AS A WHOLE WITHOUT THE WRITTEN PERMISSION OF A.I.G. ELECTRON METAL INC IS PROHIBITED.

CONFIDENTIEL
L'INFORMATION CONTENUE DANS CE DESSIN EST L'ENTIERE PROPRIÉTÉ D'ELECTRON METAL A.I.G. INC. TOUTE REPRODUCTION PARTIELLE OU EXHAUSTIVE SANS PERMISSION ÉCRITE D'ELECTRON METAL A.I.G. INC. EST INTERDITE.

DESSINÉ PAR/DRAWN BY:

VÉRIFIÉ PAR/CHECKED BY:

Title/Titre:

ADJ. HUB SHELF ASS'Y 19 x 10.5

PROJET/PROJECT:
HubShelf_6U

FICHER/FILE:
HubShelfAssy_1305026007_WebSite

REV./REV.:
-

NO. DE PIÈCE/PART NO.:
WMB-0020027-002

NO. DE DESSIN/DRAWING NO.:
1305026007

ECHELLE/SCALE:
1:5.33333

DATE:
2008-10-08

PAGE/SHEET:
2 / 2