

NO.	NOTE	DESCRIPTION	QTY
1	2286-002 - 6 x 9	BODY 44RU (77)	1
2	1305020805 - 7.75"	SPOOL BRACKET	8
3	2286-003	2 WAY BEVELLED DOOR 44RU 6 x (77)	1
4	1305020804 - 3.5"	SPOOL END PLATE	8
5	1305020806 - 7.75"	SPOOL	8
6	1305038739 - 5.25"	PLASTIC CABLE MGT FINGERS	2
7	1305038739 - 8.75"	PLASTIC CABLE MGT FINGERS	16

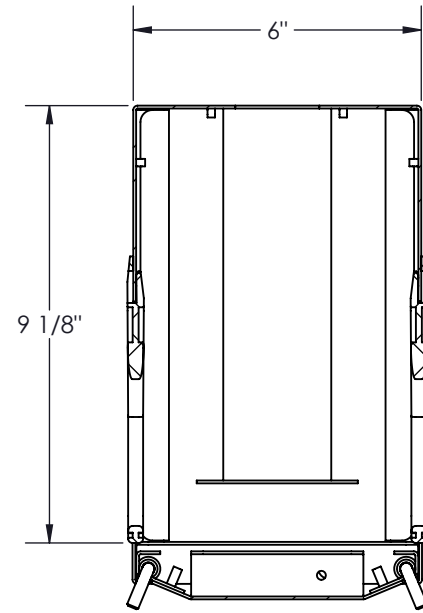

SECTION B-B  
SCALE 1 : 4

RÉV.	DESCRIPTION	DATE	APPR.	INV.
RÉVISIONS				

**Electron METAL** PROUDLY MANUFACTURED IN CANADA.

**PROPRIETARY AND CONFIDENTIAL**  
THE INFORMATION CONTAINED IN THIS DRAWING IS THE SOLE PROPERTY OF A.I.G. ELECTRON METAL INC. ANY REPRODUCTION IN PART OR AS A WHOLE WITHOUT THE WRITTEN PERMISSION OF A.I.G. ELECTRON METAL INC IS PROHIBITED.

DRAWN BY:  
E.D.  
CHECKED BY:  
E.D.

Title:  
**HIGH DENSITY CABLE MGT 6 x (77) x 9 WITH DOOR**

PROJECT:  
G:\SWDwgs\Racks\Zone4\_4PostRack\GestionsCables\Simple\Ensembles\

FILE:  
GestHD6x77x9AvecPorte\_2286-001\_Eng

PART NO.:  
CMRHZD-064409

DRAWING NO.:  
2286-001

REV.:  
-

SCALE:  
1:16

DATE:  
2018-04-26

SHEET:  
1 / 1

APPROVED BY: