

| COLOR | PT# SUFFIX |
|-------|------------|
| BLACK | -BK |
| WHITE | -WH |
| GREY | -GY |

| DESCRIPTION | NO. DE PIÈCE | DIM. DE LA PIÈCE | A |
|-------------|--------------|------------------|--------|
| CLOISON 24" | CLOISSON 24" | 23.875 x 7.218 | 23.875 |
| CLOISON 30" | CLOISSON 30" | 29.875 x 7.218 | 29.875 |

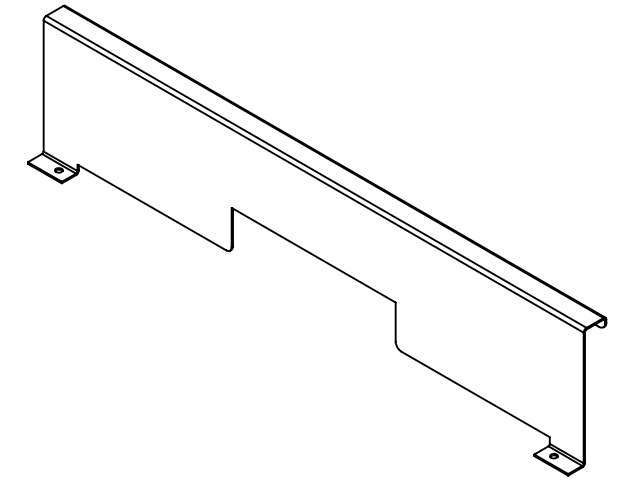
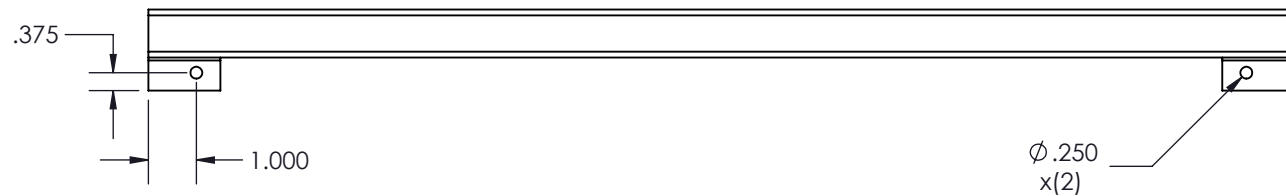

NOTES:

- 1 - WEIGHT. APPROX : 2.32 LBS
- 2 - MAT'L: STEEL CRS GAUGE 16 (0.060")

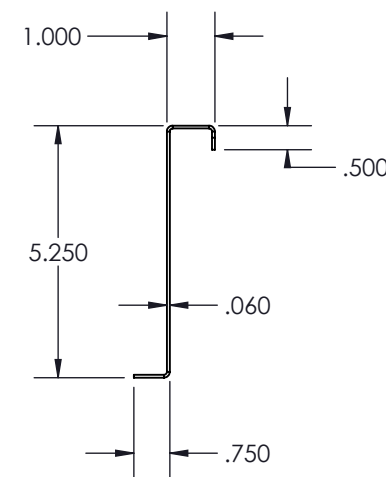
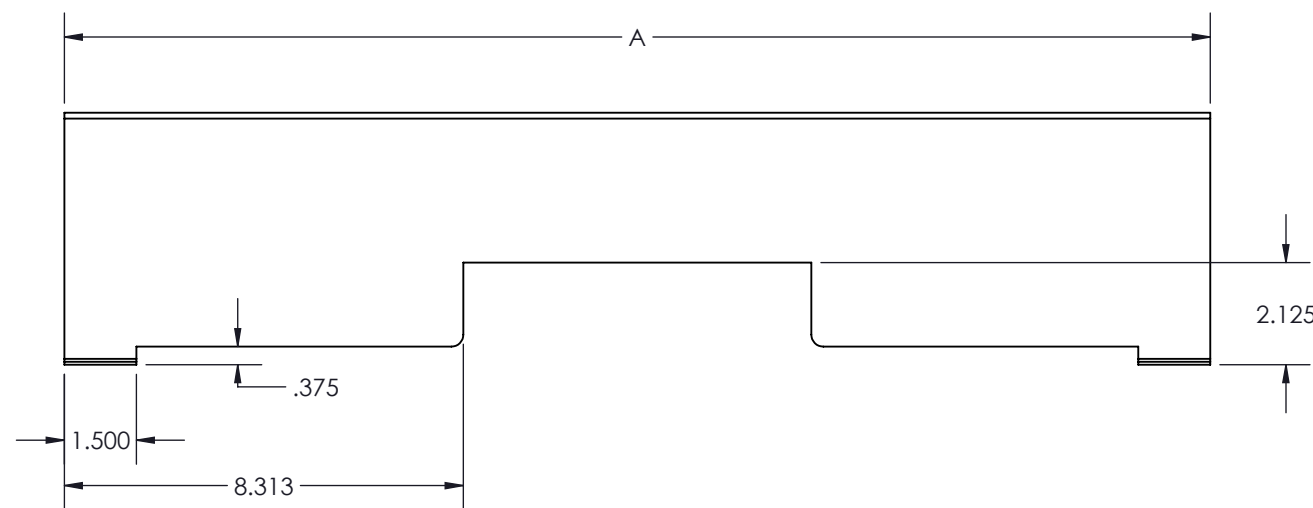

Electron METAL PROUDLY MANUFACTURED IN CANADA

CONFIDENTIAL
THE INFORMATION CONTAINED IN THIS DRAWING IS THE SOLE PROPERTY OF ELECTRON METAL A.I.G. INC. ANY REPRODUCTION IN PART OR AS A WHOLE WITHOUT THE WRITTEN PERMISSION OF A.I.G. ELECTRON METAL INC IS PROHIBITED.

| | | |
|----------------------|------------------------|---------------------------|
| APPROVED BY: E.D. | NEXT STEP: PEINTURE | CFG SHOWN: (21) x 5.25 |
|----------------------|------------------------|---------------------------|

| | | | | | |
|-------------------------|---------------------------------------|---|-----------------|---------------|--------------|
| CFG DWN BY: N/A | TITLE: CABLE PARTITION WITH CUTOUT | FILE: CloissonCables_1305028587_Eng | | | |
| CFG CHECKED BY: N/A | | PROJECT: G:\SWDwgs\Cabinets\Ser4000\CloissonsCables\ | REV.: A | SCALE: 1:4 | DATE: N/A |
| MATERIAL: 16 GA. CRS | DWG NO.: 1305028587 | DATE: N/A | SHEET: 1 / 1 | | |