

COLOUR	PT# SUFFIX
BLACK	-BK
WHITE	-WH
GREY	-GY

NO.	DWG/SUPPLIER	CFG/SUPPLIER NO.	DESCRIPTION	QTY
1	1930-010	Default	SEISMIC FRAME V4 - 48RU - 30 x 90 x 42	1
2	2284-004	(84")	REINFORCED MTG RAIL CAGE-NUT 4.25" FOR BRUSH	4
3	1305021152	Default	VERTICAL CABLE MGT 3.25 x (84) x 5	2
4	2472-002	Default	UAC / VCM 48RU 1 x (84) x 6	1
5	2531-001	(25) x 42	TOP FRONT COVER SEISMIQUE V4	1
6	1741-001	(27)	TOP COVER FOR BRUSH	1
7	1305038320	Default	TOP FRONT COVER PLATE	2
8	2647-003	Default	PERFORATED DOOR (25 x 84)	1
9	2450-007	Default	SPLIT DOOR PERFORATED RH (25 x 84)	1
10	2450-006	Default	SPLIT DOOR PERFORATED L.H. (25 x 84)	1
11	2532-001	Default	HALF SPLIT SIDE PANEL 42"D	4
12	2629-001	Default	LEVELLING SHIM	8

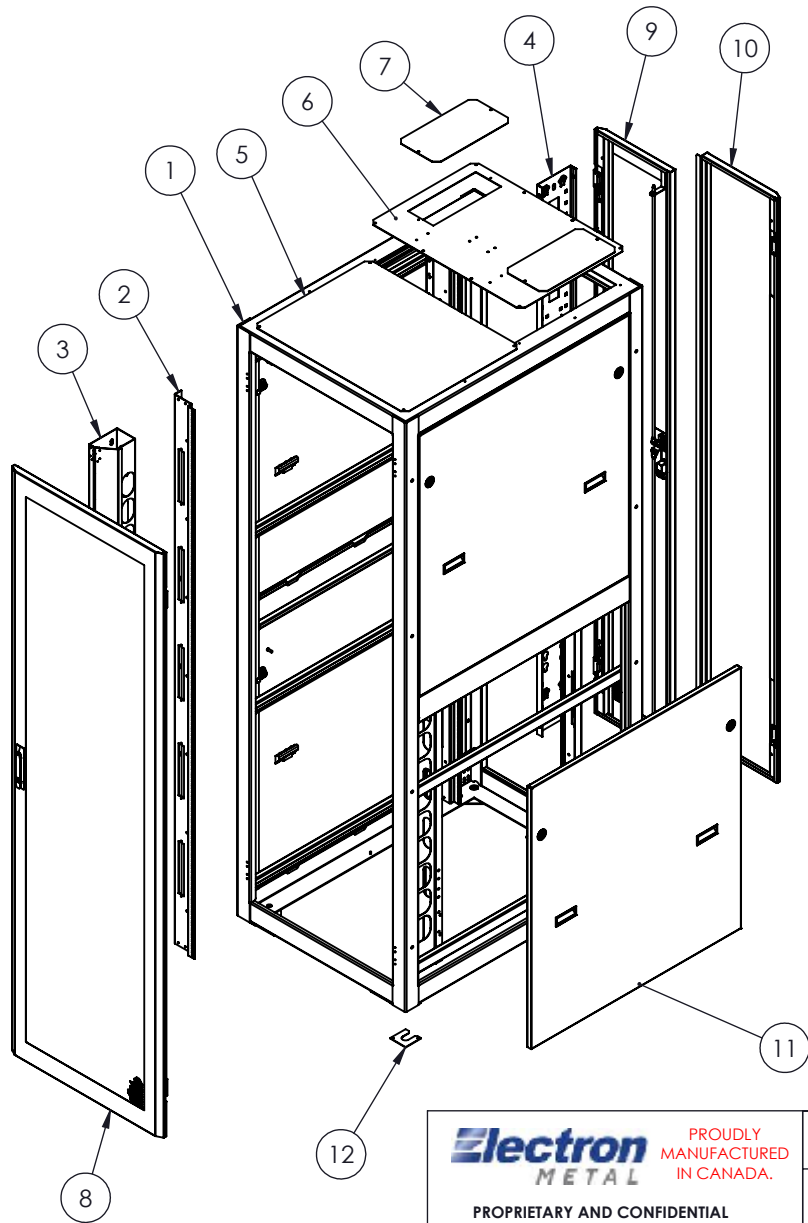

NOTES:

- 1 - CERTIFIED TO:
 - BELLCORE GR-63-CORE, 4.4.1-2
 - CSA 22.2 NO. 70950-1
- 2 - APPROX. WEIGHT: 498 LB
- 3 - SEISMIC CAPACITY: 716 LB
- 4 - STATIC CAPACITY: 3000 LB
- 5 - FINISH: TEXTURED POWDER COAT
- 6 - CABINET MUST BE ANCHORED USING 4 SEISMIC RATED ANCHORS (NOT INCLUDED).
- 7 - FRAME MAT'L: 11 GA. (.120") COLD ROLLED STEEL
- 8 - ALSO INCLUDED (NOT SHOWN):
 - 100 HEAVY DUTY CAGE-NUTS 10-32
 - 100 TRUSS HEAD SCREWS 10-32 x 5/8 BLACK

APPROVED BY:
T.M.

Electron PROUDLY
METAL MANUFACTURED
IN CANADA.

PROPRIETARY AND CONFIDENTIAL
THE INFORMATION CONTAINED IN THIS
DRAWING IS THE SOLE PROPERTY OF
ELECTRON METAL A.I.G. INC. ANY
REPRODUCTION IN PART OR AS A WHOLE
WITHOUT THE WRITTEN PERMISSION OF
A.I.G. ELECTRON METAL INC IS PROHIBITED.

DRAWN BY:
E.D.

CHECKED BY:
E.D.

FILE:
CabZ4_25x84x42_2747-001_Eng

PART NO.:
CBZK14-254842

Title:
SEISMIQUE CABINET V4 48RU 30 x 90 x 42

DRAWING NO.:
2747-001

REV.:
B

SCALE:
1:24

DATE:
2019-01-29

SHEET:
1 / 2

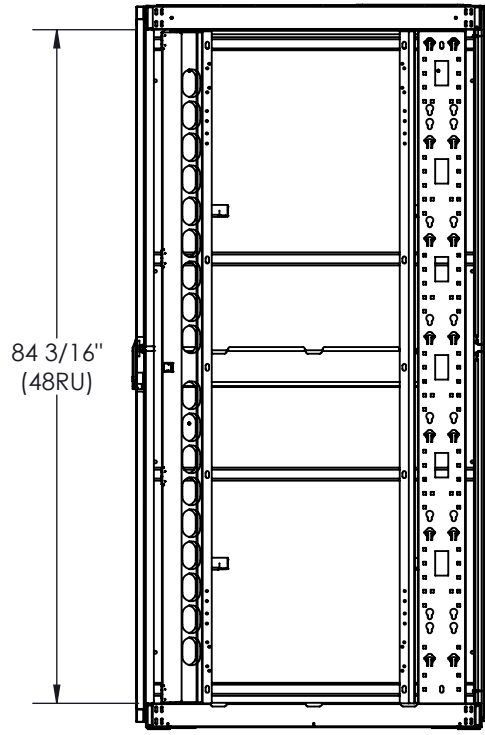
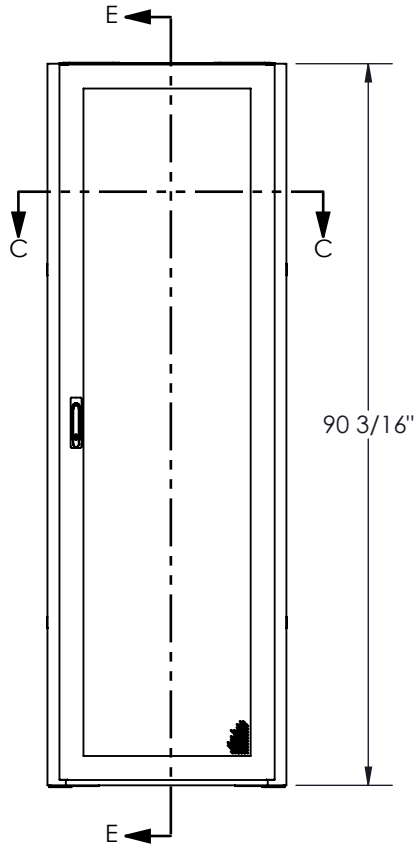

SECTION E-E

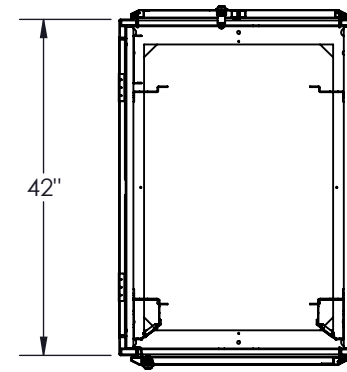

SECTION C-C

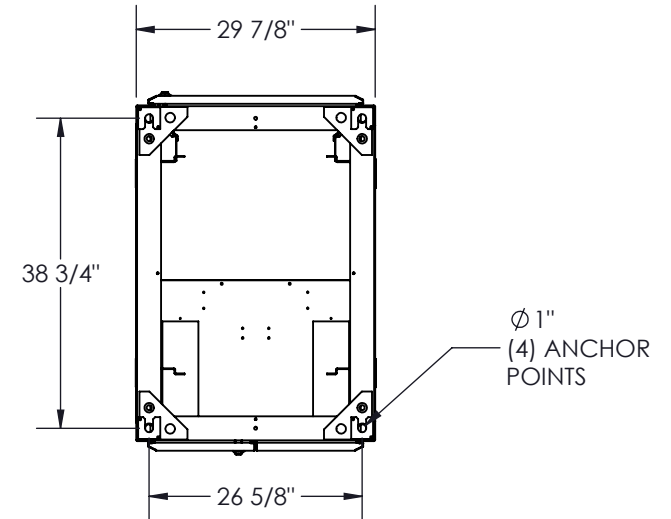

BOTTOM VIEW

Electron METAL PROUDLY MANUFACTURED IN CANADA.

PROPRIETARY AND CONFIDENTIAL
THE INFORMATION CONTAINED IN THIS DRAWING IS THE SOLE PROPERTY OF ELECTRON METAL A.I.G. INC. ANY REPRODUCTION IN PART OR AS A WHOLE WITHOUT THE WRITTEN PERMISSION OF A.I.G. ELECTRON METAL INC IS PROHIBITED.

APPROVED BY:
T.M.

DRAWN BY:
E.D.
CHECKED BY:
E.D.

Title:
SEISMIQUE CABINET V4 48RU 30 x 90 x 42

FILE:
CabZ4_25x84x42_2747-001_Eng

PART NO.:
CBZKI4-254842

DRAWING NO.:
2747-001

REV.:
B

SCALE:
1:24

DATE:
2019-01-29

SHEET:
2 / 2