

COLOUR	PT# SUFFIX
BLACK	-BK
WHITE	-WH
GREY	-GY

NO.	DWG/SUPPLIER	CFG/SUPPLIER NO.	DESCRIPTION	QTY
1	1930-013	Default	SEISMIC FRAME V4 - 44RU - 30 x 83 x 36	1
2	2284-004	(77")	REINFORCED MTG RAIL CAGE-NUT 4.25" FOR BRUSH	4
3	1305021980	Default	VERTICAL CABLE MGT 3.25 x (77) x 5	2
4	1725-001	Default	VERTICAL CABLE MGT / U.A.C. 44RU (77) x 6	1
5	1741-001	(27)	TOP COVER FOR BRUSH	1
6	1305038320	Default	TOP FRONT COVER PLATE	2
7	2531-001	(25) x 36	TOP FRONT COVER SEISMIQUE V4	1
8	2647-006	Default	PERFORATED DOOR (25 x 77)	1
9	1967-007	Default	SPLIT DOOR PERF. RH (25 x 77)	1
10	1967-008	Default	SPLIT DOOR PERF. L.H. (25 x 77)	1
11	2532-009	Default	HALF SPLIT SIDE PANEL 36"D	4
12	2629-001	Default	LEVELLING SHIM	8

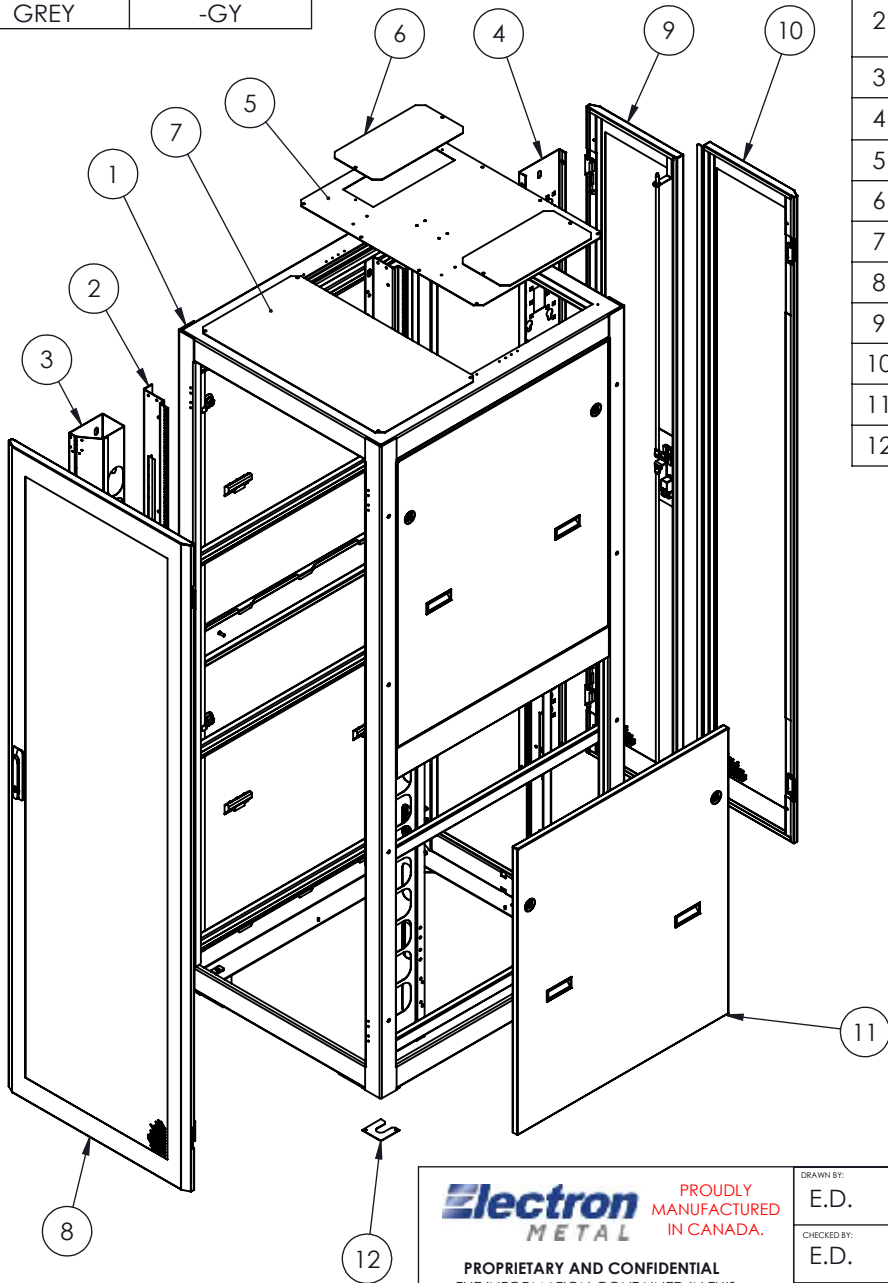

NOTES:

- 1 - CERTIFIED TO:
  - BELLCORE GR-63-CORE, 4.4.1-2
  - CSA 22.2 NO. 70950-1
- 2 - APPROX. WEIGHT: 439 LB
- 3 - SEISMIC CAPACITY: 775 LB
- 4 - STATIC CAPACITY: 3000 LB
- 5 - FINISH: TEXTURED POWDER COAT
- 6 - CABINET MUST BE ANCHORED USING 4 SEISMIC RATED ANCHORS (NOT INCLUDED).
- 7 - FRAME MAT'L: 11 GA. (.120") COLD ROLLED STEEL
- 8 - ALSO INCLUDED (NOT SHOWN):
  - 100 HEAVY DUTY CAGE-NUTS 10-32
  - 100 TRUSS HEAD SCREWS 10-32 x 5/8 BLACK

APPROVED BY:  
T.M.

**Electron** PROUDLY MANUFACTURED IN CANADA.  
**METAL**

PROPRIETARY AND CONFIDENTIAL  
THE INFORMATION CONTAINED IN THIS DRAWING IS THE SOLE PROPERTY OF ELECTRON METAL A.I.G. INC. ANY REPRODUCTION IN PART OR AS A WHOLE WITHOUT THE WRITTEN PERMISSION OF A.I.G. ELECTRON METAL INC IS PROHIBITED.

DRAWN BY:  
E.D.

CHECKED BY:  
E.D.

FILE:  
CabZ4\_25x77x36\_2747-002\_Eng

PART NO.:  
CBZKI4-254436

Title:  
SEISMIQUE CABINET V4 - 44RU 30 x 83 x 36

DRAWING NO.:  
2747-002

REV.:  
B

SCALE:  
1:20

DATE:  
2019-07-10

SHEET:  
1 / 2

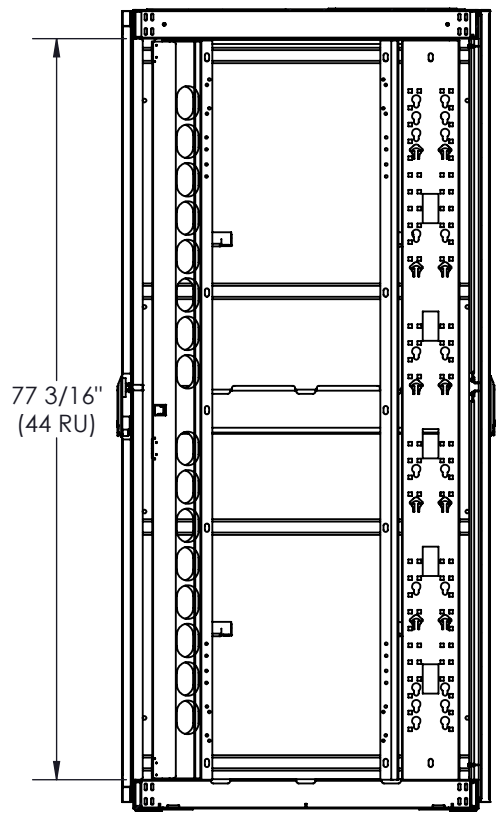
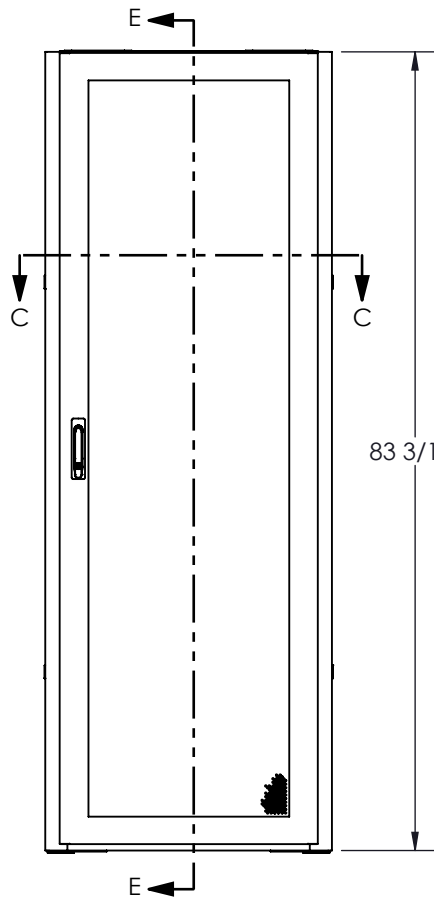

SECTION E-E

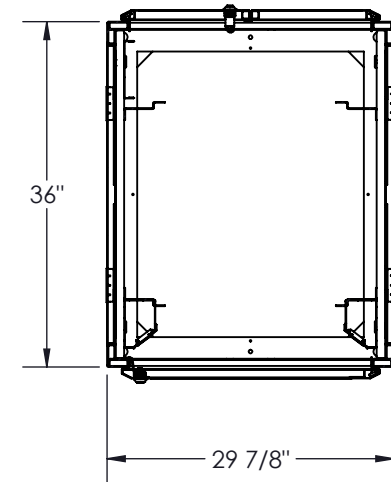

SECTION C-C

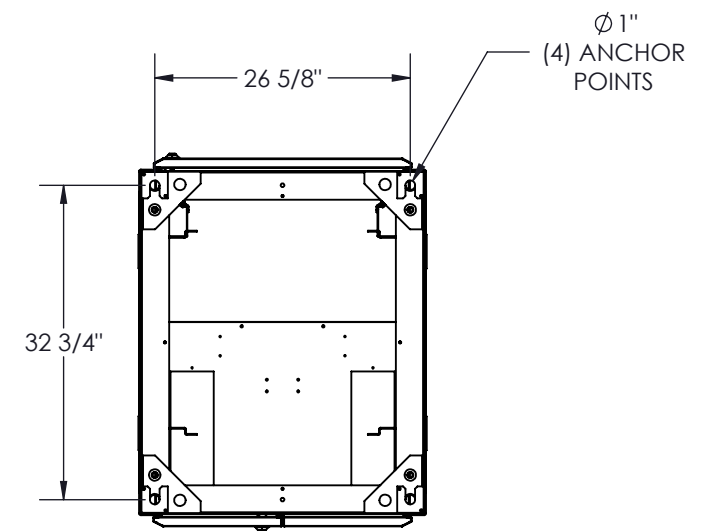

BOTTOM VIEW

**Electron METAL** PROUDLY MANUFACTURED IN CANADA.

PROPRIETARY AND CONFIDENTIAL  
 THE INFORMATION CONTAINED IN THIS DRAWING IS THE SOLE PROPERTY OF ELECTRON METAL A.I.G. INC. ANY REPRODUCTION IN PART OR AS A WHOLE WITHOUT THE WRITTEN PERMISSION OF A.I.G. ELECTRON METAL INC IS PROHIBITED.

APPROVED BY:  
 T.M.

DRAWN BY:  
 E.D.  
 CHECKED BY:  
 E.D.

Title:  
 SEISMIQUE CABINET V4 - 44RU 30 x 83 x 36

FILE:  
 CabZ4\_25x77x36\_2747-002\_Eng

PART NO.:  
 CBZKI4-254436

DRAWING NO.:  
 2747-002

REV.:  
 B

SCALE:  
 1:20

DATE:  
 2019-07-10

SHEET:  
 2 / 2