

COLOUR	PT# SUFFIX
BLACK	-BK
WHITE	-WH
GREY	-GY

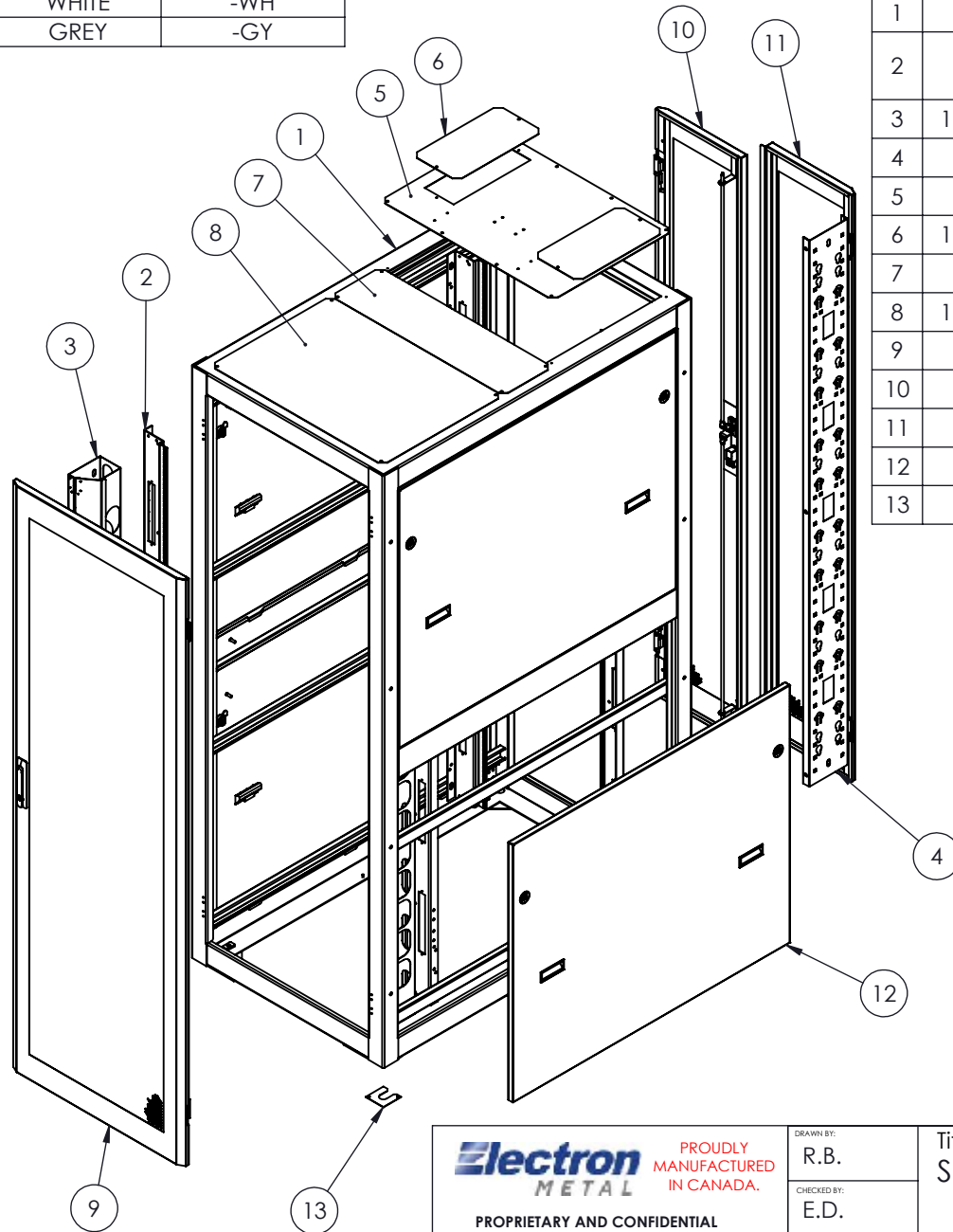

NO.	DWG/ SUPPLIER	CFG/ SUPPLIER NO.	DESCRIPTION	QTY
1	1930-021	Default	SEISMIC FRAME V4 - 42RU - 30 x 79.5 x 48	1
2	2284-004	(73.5")	REINFORCED MTG RAIL CAGE-NUT 4.25" FOR BRUSH	4
3	1305025833	Default	CABLE MGT 3.25 x (73.5) x 5	2
4	2413-001	Default	VERTICAL CABLE MGT / U.A.C. (73.5) x 6	1
5	1741-001	(27)	TOP COVER FOR BRUSH	1
6	1305038320	Default	TOP FRONT COVER PLATE	2
7	2531-002	(25")	TOP COVER MIDDLE Z4 - 48"D	1
8	1305028296	(27)	SERIES 4000 SOLID TOP COVER	1
9	2647-008	Default	PERFORATED DOOR (25 x 73.5)	1
10	1967-012	Default	SPLIT DOOR PERF. RH (25 x 73.5)	1
11	1967-011	Default	SPLIT DOOR PERF. L.H. (25 x 73.5)	1
12	2532-013	Default	HALF SPLIT SIDE PANEL (73.5) x 48	4
13	2629-001	Default	LEVELLING SHIM	8

NOTES:

- 1 - CERTIFIED TO:
 - BELLCORE GR-63-CORE, 4.4.1-2
 - CSA 22.2 NO. 70950-1
- 2 - APPROX. WEIGHT: 475 LB
- 3 - SEISMIC CAPACITY: 739 LB
- 4 - STATIC CAPACITY: 3000 LB
- 5 - FINISH: TEXTURED POWDER COAT
- 6 - CABINET MUST BE ANCHORED USING 4 SEISMIC RATED ANCHORS (NOT INCLUDED).
- 7 - FRAME MAT'L: 11 GA. (.120") COLD ROLLED STEEL
- 8 - ALSO INCLUDED (NOT SHOWN):
 - 100 HEAVY DUTY CAGE-NUTS 10-32
 - 100 TRUSS HEAD SCREWS 10-32 x 5/8 BLACK

Electron PROUDLY MANUFACTURED IN CANADA.
METAL

PROPRIETARY AND CONFIDENTIAL
THE INFORMATION CONTAINED IN THIS DRAWING IS THE SOLE PROPERTY OF ELECTRON METAL A.I.G. INC. ANY REPRODUCTION IN PART OR AS A WHOLE WITHOUT THE WRITTEN PERMISSION OF A.I.G. ELECTRON METAL INC IS PROHIBITED.

APPROVED BY:
E.D.

DRAWN BY:
R.B.
CHECKED BY:
E.D.

Title:
SEISMIQUE CABINET V4 - 42RU 30 x 79.5 x 48

FILE:
CabZ4_25x73x48_2747-007_Eng

PART NO.:
CBZKI4-254248

DRAWING NO.:
2747-007

REV.:

SCALE:
1:20

DATE:
2021-06-08

SHEET:
1 / 2

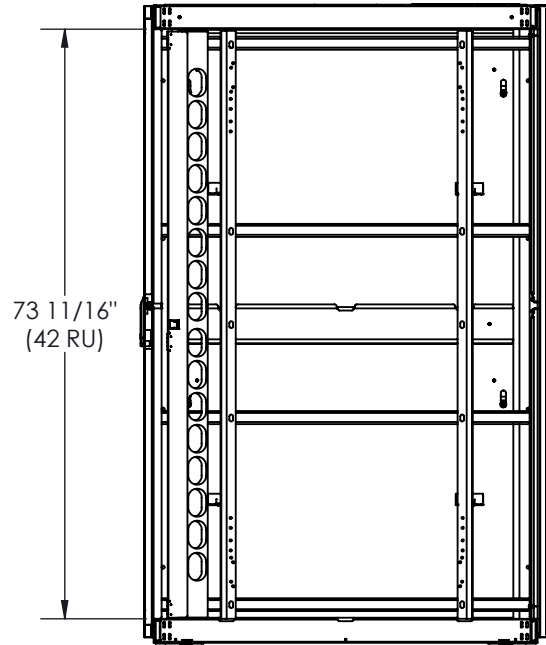
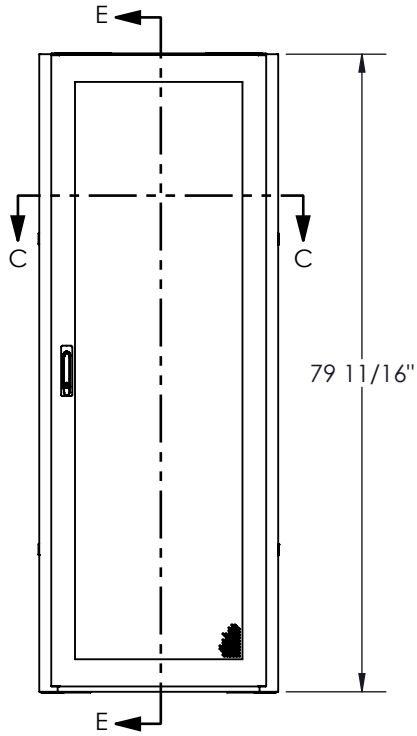

SECTION E-E

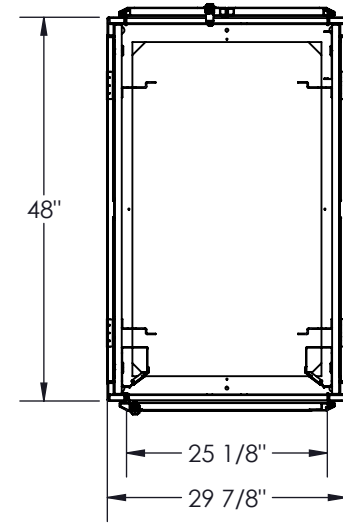

SECTION C-C

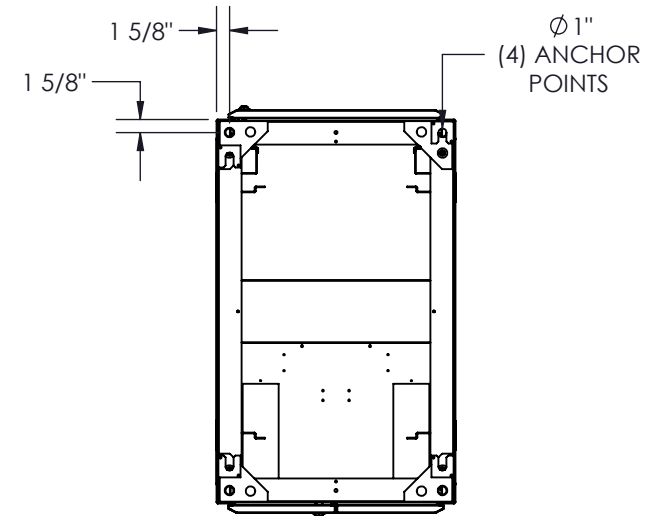

BOTTOM VIEW

Electron METAL PROUDLY MANUFACTURED IN CANADA.

PROPRIETARY AND CONFIDENTIAL
 THE INFORMATION CONTAINED IN THIS DRAWING IS THE SOLE PROPERTY OF ELECTRON METAL A.I.G. INC. ANY REPRODUCTION IN PART OR AS A WHOLE WITHOUT THE WRITTEN PERMISSION OF A.I.G. ELECTRON METAL INC IS PROHIBITED.

APPROVED BY:
E.D.

DRAWN BY:
R.B.
CHECKED BY:
E.D.

FILE:
CabZ4_25x73x48_2747-007_Eng

PART NO.:
CBZKI4-254248

Title:
SEISMIQUE CABINET V4 - 42RU 30 x 79.5 x 48

DRAWING NO.:
2747-007

REV.:

SCALE:
1:24

DATE:
2021-06-08

SHEET:
2 / 2