

COLOR	PT# SUFFIX
BLACK	-BK
WHITE	-WH
GREY	-GY

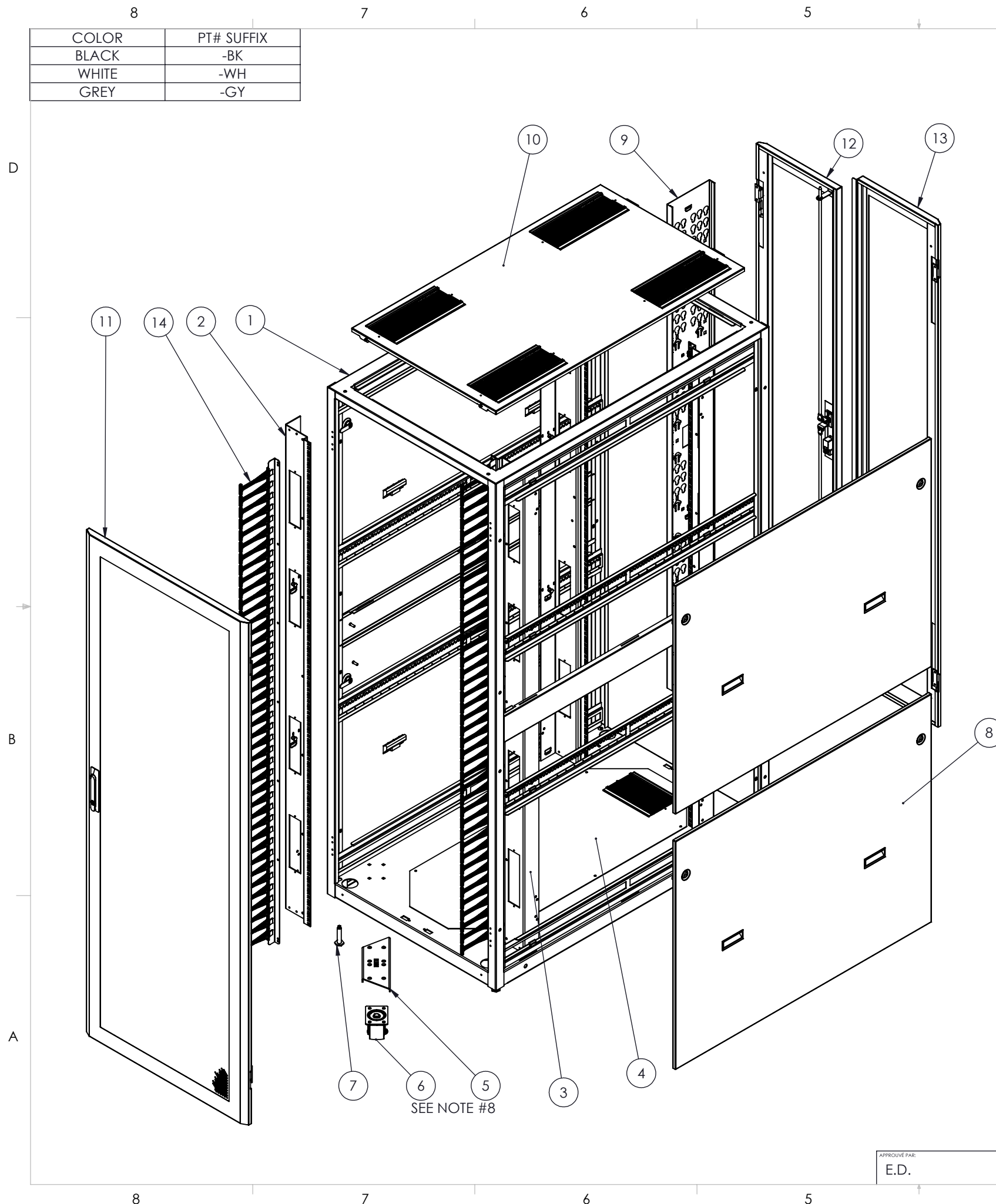

NO.	DWG/SUPPLIER	CFG/SUPPLIER NO.	DESCRIPTION	QTY
1	3222-013	Default	FRAME 42RU (27 x 73.5) x 48	1
2	3189-011	Default	MTG RAIL 5.063 x (73.5) ASS'Y RH	2
3	3189-011	Default	MTG RAIL 5.063 x (73.5) ASS'Y LH	2
4	2114-003	Default	BOTTOM COVER WITH DBL BRUSH 4 x 8 - 48D	1
5	3236-001	Default	A5000 CASTER PLATE	4
6	03PO201B8106YY	Default	2" SWIVEL CASTER - 250 LBS	4
7	OHIO NUT & BOLT	FHP 4441	LEVELLER, STEEL BASE 1/2-13, HEX. END	4
8	2368-005	Default	SPLIT SIDE PANEL (73.5) x 48 LOCKS	2
9	3191-011	Default	A5000 U.A.C. 42RU (73.5) x 7.5 ASS'Y	1
10	3639-003	Default	TOP COVER (27) x 48 WITH BRUSH	1
11	3180-007	Default	A5000 PERFORATED DOOR (27 x 73.5)	1
12	3183-010	Default	A5000 SPLIT DOOR PERFORATED RH (27 x 73.5)	1
13	3183-011	Default	A5000 SPLIT DOOR PERFORATED L.H. (27 x 73.5)	1
14	1832-005	Default	HIGH DENSITY RAIL CABLE MGT (73.5")	2

NOTES:

- 1 - RU DECALS ON HORIZONTAL RAILS.
- 2 - RU MARKINGS PRINTED ON VERTICAL RAILS.
- 3 - 100 CAGE-NUTS HEAVY DUTY (TINNERMAN)
- 4 - 100 SCREWS 10-32 x 5/8 BLACK
- 5 - 4 GANGING PLATES
- 6 - ESTIMATED WEIGHT: 423.30 LB
- 7 - FINISH: TEXTURED POWDER COAT
- 8 - FASTEN CASTERS USING:
 - 1/4-20 x 3/4 ELEVATOR BOLTS
 - 1/4" FLAT WASHERS
 - 1/4-20 K-LOC NUTS

REV.	DESCRIPTION	DATE	APPR.	STOCK
REVISIONS				

<p>FABRIQUÉ AVEC FIERTÉ AU QUÉBEC.</p> <p>CONFIDENTIEL L'INFORMATION CONTENUE DANS CE DESSIN EST L'ENTIÈRE PROPRIÉTÉ D'ELECTRON METAL A.I.G. INC. TOUTE REPRODUCTION PARTIELLE OU EXHAUSTIVE SANS PERMISSION ÉCRITE D'ELECTRON METAL A.I.G. INC. EST INTERDITE.</p>	DESSINÉ PAR/DRAWN BY: M.W. VÉRIFIÉ PAR/CHECKED BY: NOT CHECKED	TITRE/TITLE: A5000 42RU (27 x 73.5) x 48 OVERALL DIMS: 29.625 x 77 x 50.35
	FICHER/FILE: A5000_27x73p5x48_3221-008	NO. DE PIÈCE/PART NO.: CB5KNH-274248
APPROUVÉ PAR: E.D.	REV./REV.: A	ÉCHELLE/SCALE: 1:14
	DATE: 2024/04/04	PAGE/SHEET: 1 / 2

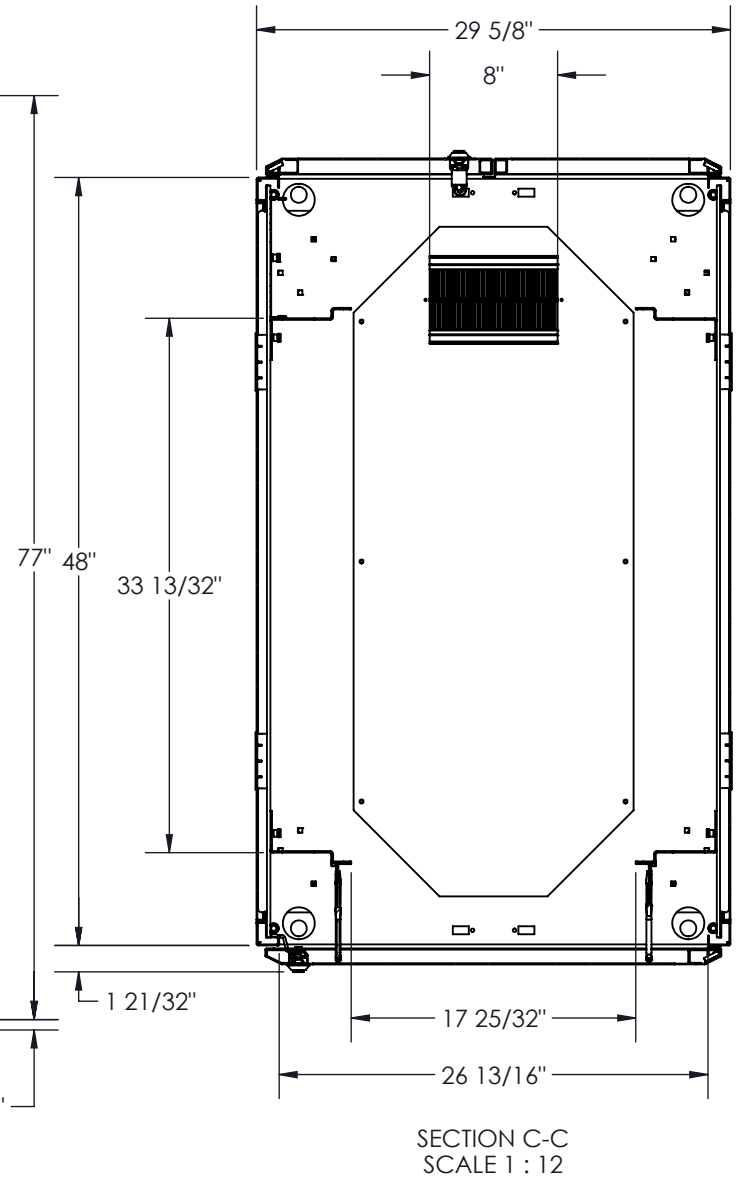
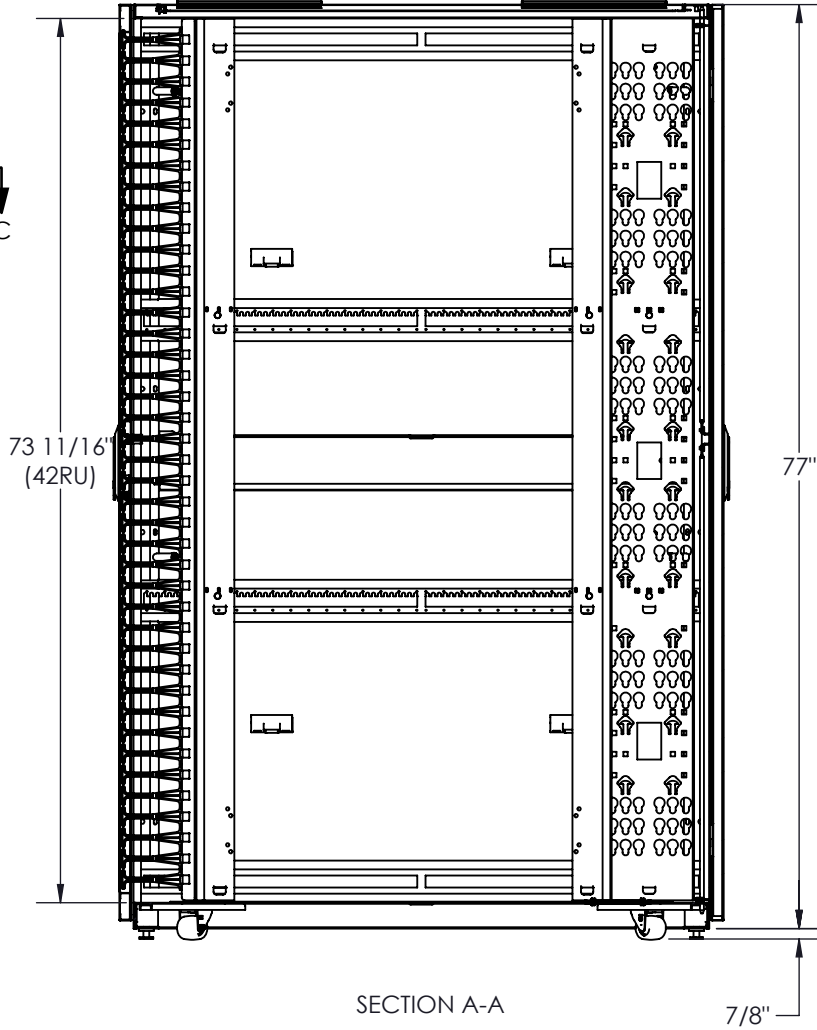
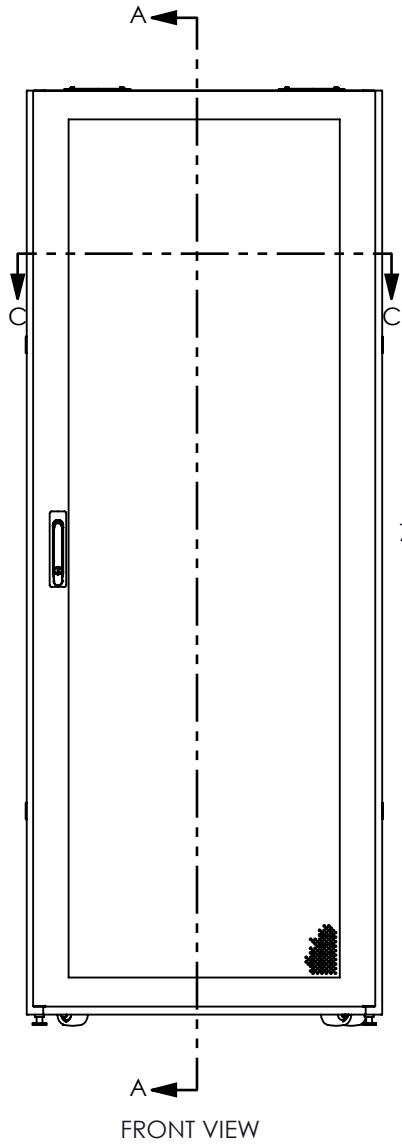

Electron PROUDLY MANUFACTURED IN CANADA.
METAL

PROPRIETARY AND CONFIDENTIAL
THE INFORMATION CONTAINED IN THIS DRAWING IS THE SOLE PROPERTY OF ELECTRON METAL A.I.G. INC. ANY REPRODUCTION IN PART OR AS A WHOLE WITHOUT THE WRITTEN PERMISSION OF A.I.G. ELECTRON METAL INC IS PROHIBITED.

DRAWN BY:
M.W

CHECKED BY:
NOT CHECKED

FILE:
A5000_27x73p5x48_3221-008

PART NO.:
CB5KNH-274248

Title:
A5000 42RU (27 x 73.5) x 48
OVERALL DIMS: 29.625 x 77 x 50.35

APPROVED BY:
E.D.

DRAWING NO.:
3221-008

REV.:
A

SCALE:
1:16

DATE:
2024/04/04

SHEET:
2 / 2