

With Water Flowing , Rowing At Home

SHUA Wooden Water Resistance Rower



Solid Beech



Polycarbonate Water Tank



Four Paddles and Sixteen Strokes



Adjustable Footrests



Convenient Mobile Roller



Comfortable Non-Slip Cushion



0.26M2 Covering



Electric Water Pump



SH-R598
SHUA Wooden Water Resistance Rower

Elegant Rowing

Lateral Exercise, Free Knees

The design of virtual rowing brings the beauty of elegant fitness. Comparing with standing exercise, rower is rather a lateral position exercise, and it is much lighter on the knees, which can protect you knees from gravity and double movement.

All-Round Muscle Workout

Build All Kinds of Main Muscle Groups



Wall-Leaned, Easy Upright Storage

Use the vertical storing design, it can be stored in upright position in one second, and only covers an area of 0.26m^2 . With convenient mobile rollers, move it only needs lightly lifting.

Whole Body Length

2035 mm

Whole Body Width

515 mm

Water Tank Capacity

≤15L

Maximum User's
Weight

150 KG



0.26m²

Polycarbonate Water Tank

Big Capacity offers Greater Resistance

Select water tank with big capacity because it can store much more water, which gives greater resistance; It features good impact resistance, leakproof, and also more durable.



Good Water Tank,
Has to Be Durable



With Impact Resistance,
Durability, and Uneasy
to Leak Water for
Long-Time Use

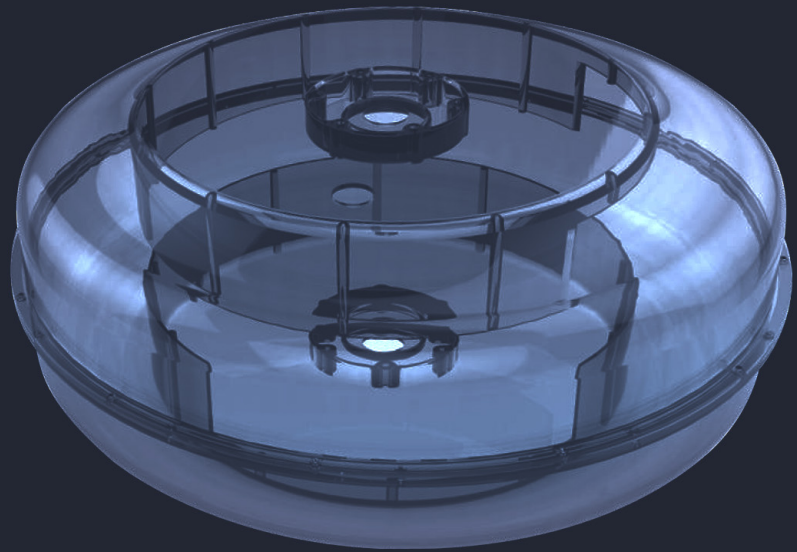

Four Paddles and Sixteen Strokes, Paddle Set More Stable When Export Resistance

The innovative design, the four flywheels and sixteen strokes paddle set, enable paddle to fully touch and distribute water, which brings more uniform water resistance to smooth row.

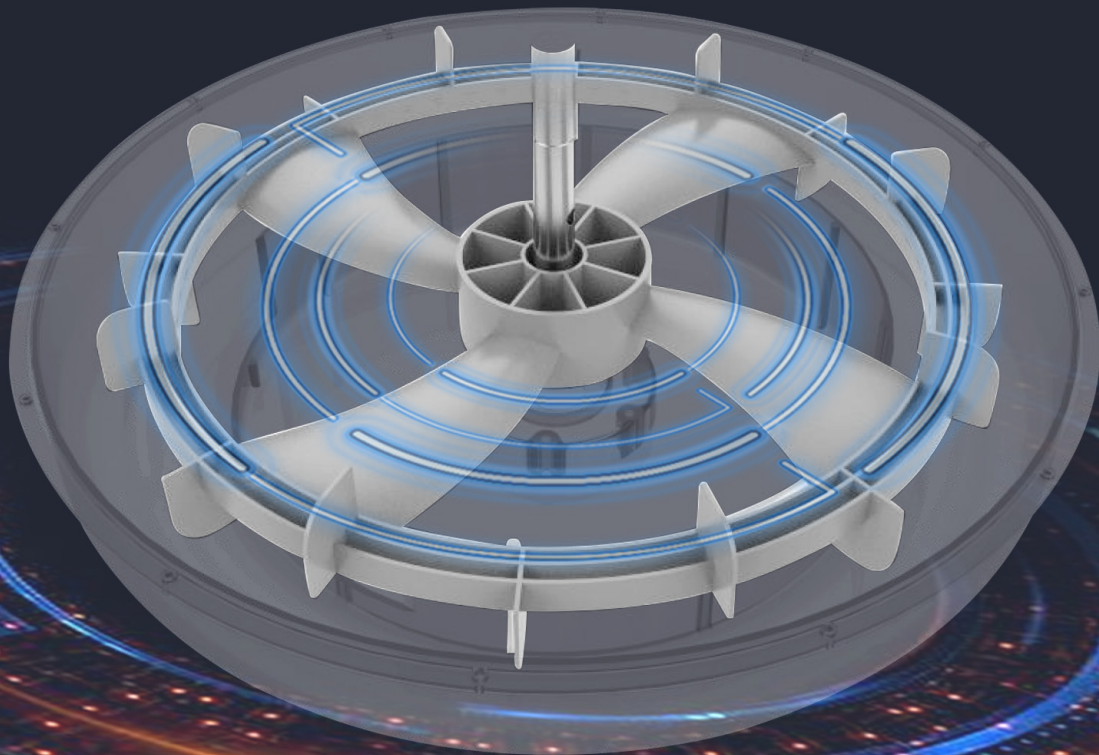

Interesting Workout Unlock Rower's New Feature

More than just rowing, it has fun exercise positions for you to explore. Have a simpler and funner exercise!

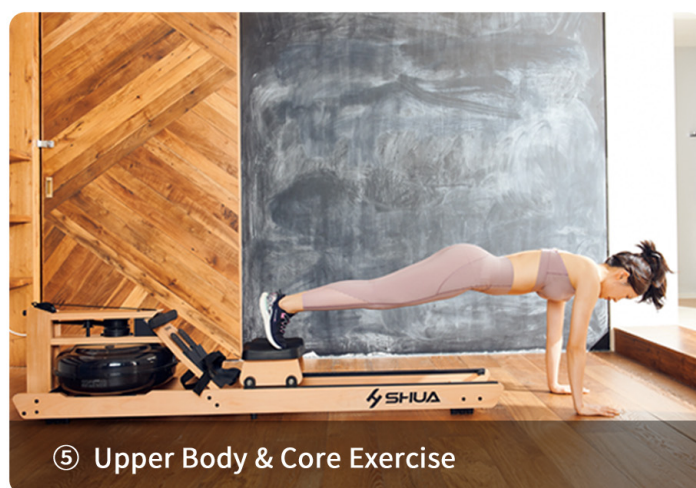
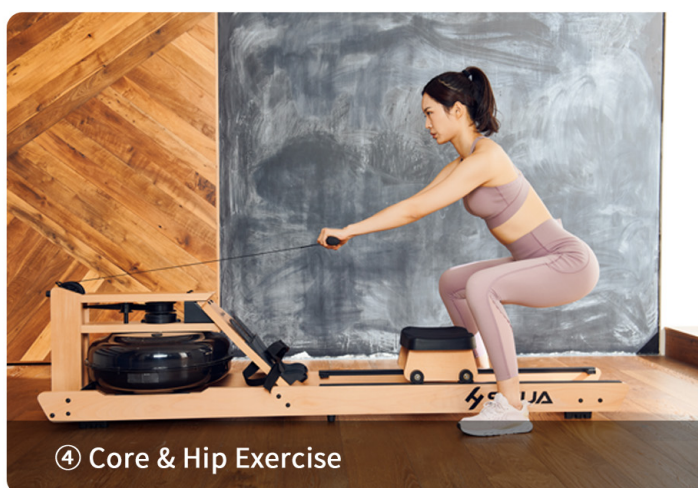
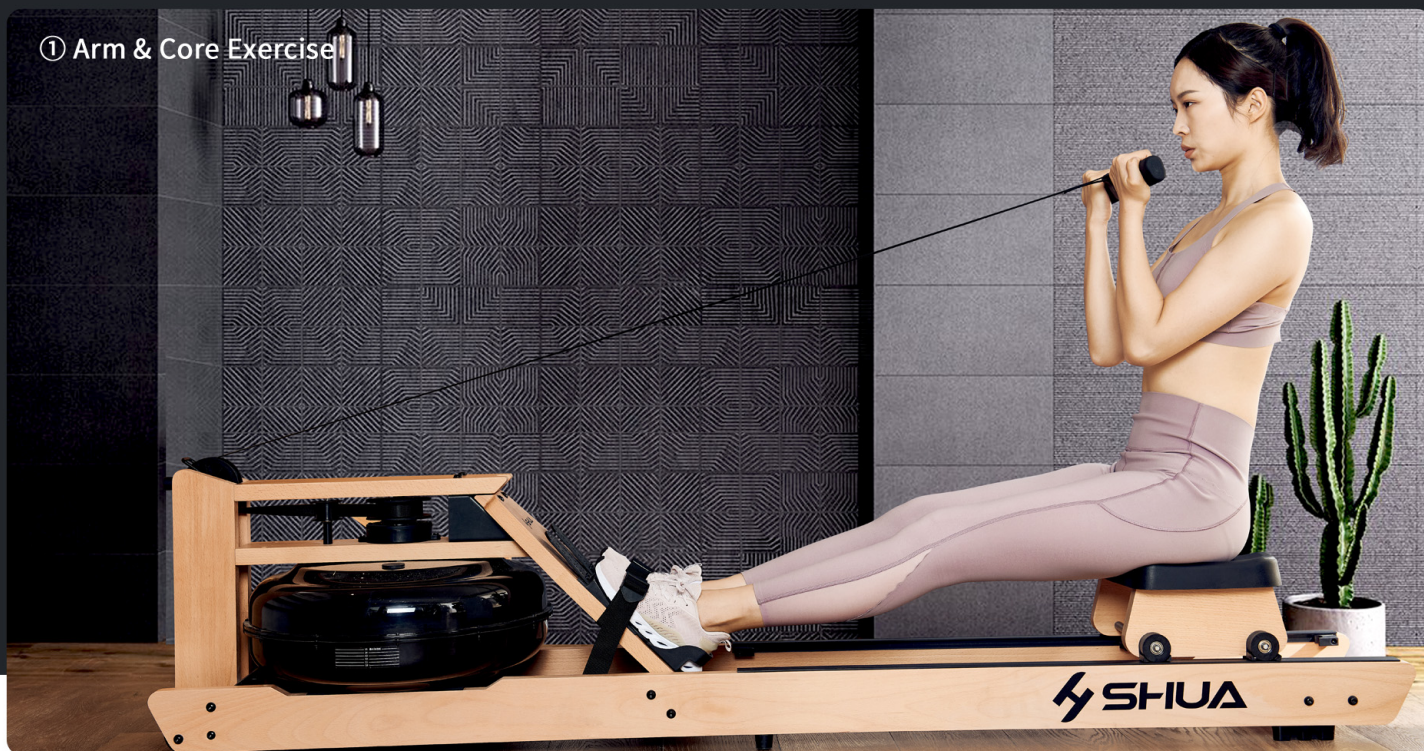

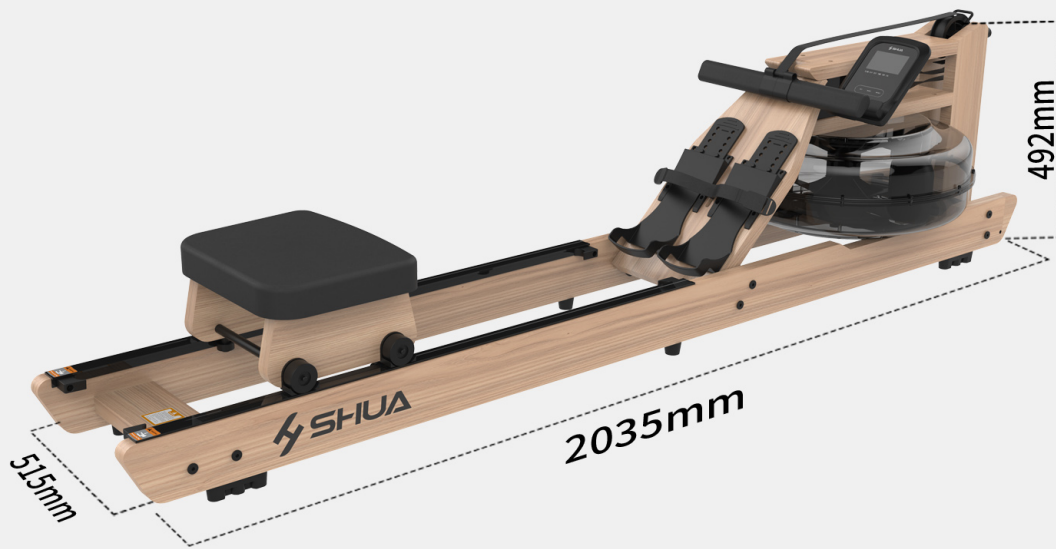

PRODUCT PARAMETERS

SH-R598
SHUA Wooden Water Resistance Rower

Product Name

SHUA Wooden Water Resistance Rower

Product Type

SH-R598

Frame Material

Beech

Resistance

Water Resistance

N.W.

34KG

G.W.

28.5KG

Water Tank

PC Polycarbonate

Maximum Users' Weight

<150KG

Sliding Rail

PVC Double Rails, Wearproof PVC

Suitable Crowd

All-aged People

Product Dimension

2035x515x492mm

Exercise Parts

Arms and Legs/ Shoulders and Back/
Waist and Abdomen

Package Dimension

A Package: 986x528x491mm
B Package: 2090x140x100mm

Water Volume

<15L Suggests less than 15L