

# POWER-FLEX™ 4

Owner's Manual and Reference Guide



Power-Flex™ Adjustable Base built by:



## **Congratulations on your Power-Flex™ 4 Adjustable Base!**

This manual has just about everything you need to know about your new Power-Flex™ Adjustable Base. If you need anything else, there is contact information for you throughout the manual. You may notice as you read that all the customer service and warranty information refers you to Reverie. Here's why:

Power-Flex™ has designed a Adjustable Base to optimize performance on our air adjustable mattresses. We have contracted with Reverie to manufacture and to administer post-sale service and support for the Power-Flex™ Adjustable Base line. Reverie has a nationwide network of service experts with years of experience and a high level of expertise in adjustable bed foundations.

We are confident that partnering with Reverie and utilizing their expertise is the best way to provide you with a great service experience, should you need assistance with your Power-Flex™ Adjustable Base.

Thank you for choosing Power-Flex™!

# POWER-FLEX™ 4

## Table of Contents

Safety Precautions.....	4
Parts List.....	9
Adjustable Base Assembly Instructions .....	10
Downloadable App Operation.....	14
Wireless Remote Control.....	17
Remote Control Operation Guide.....	18
Replacement Remote Control Programming.....	20
Adjustable Base Key Features.....	23
Troubleshooting.....	24
Warranty.....	27

**Warranty Information: Please see warranty information at the end of this manual**



**CUSTOMER SERVICE: 800-973-8374**  
service@personalcomfort.com

### SAFETY PRECAUTIONS

**WARNING! IMPORTANT SAFETY INSTRUCTIONS.  
PLEASE READ THESE INSTRUCTIONS  
THOROUGHLY BEFORE USING THIS PRODUCT.  
SAVE THESE INSTRUCTIONS!**

When using an electrical furnishing basic precautions should always be followed, including the following:

#### **READ ALL INSTRUCTIONS BEFORE USING (THIS FURNISHING)**

**DANGER:** To reduce the risk of electric shock:  
Always unplug this furnishing from the electrical outlet before cleaning.

**WARNING:**  
To reduce the risk of burns, fire, electric shock, or injury to persons:

- Unplug from outlet before putting on or taking off parts.
- Close supervision is necessary when this furnishing is used by or near children, invalids or disabled persons.
- Use this furnishing only for its intended use as described in these instructions. Do not use attachments not recommended by the manufacturer.
- Never operate this furnishing if it has a damaged cord or plug, or if it is not working properly, dropped or damaged, or dropped into the water. Return the furnishing to a service center for examination and repair.
- Keep the cord away from heated surfaces.
- Never operate the furnishing with the air openings blocked. Keep the air openings free of lint, hair and the like.
- Never drop or insert any object into any opening.
- Do not use outdoors.
- Do not operate where aerosol (spray) products are being used or where oxygen is being administered.
- To disconnect, turn all controls to the off position, then remove plug from outlet.
- Do not place remote in/near water or areas of intense heat.

**WARNING:** Risk of Injury:  
Keep children away from extended foot support (or other similar parts).

**WARNING:** Risk of electric shock:  
Connect this furnishing to a properly grounded outlet only.  
See Grounding instructions.

### GROUNDING INSTRUCTIONS:

This product must be grounded. If it should malfunction or breakdown, grounding provides a path of least resistance for electric current to reduce the risk of electric shock. This product is equipped with a cord having an equipment-grounding conductor and a grounding plug. The plug must be plugged into an appropriate outlet that is properly installed and grounded in accordance with all local codes and ordinances.

**DANGER:**  
Improper connection of the equipment-grounding conductor can result in a risk of electric shock. Check with a qualified electrician or serviceman if you are in doubt as to whether the product is properly grounded.

Do not modify the plug provided with the product. If it will not fit the outlet, have a proper outlet installed by a qualified electrician.

**SAVE THESE INSTRUCTIONS!**

This product is for use on a standard 120-volt circuit, and has a grounding plug that looks like the plug illustrated in photo A (see Figure). A temporary adapter that looks like the adapter illustrated in photo B and C can be used to connect this plug to a 2-pole receptacle as shown in photo B if a properly grounded outlet is not available. The temporary adapter should be used only until a properly grounded outlet (photo A) can be installed by a qualified electrician. The green colored rigid ear, lug or the like extending from the adapter must be connected to a permanent ground such as a properly grounded outlet box cover. Whenever the adapter is used, it must be held in place by a metal screw.

This product is for use on a circuit having a standard rating of 120 volts and is factory equipped with a specific electric cord and plug to permit connection to a proper electric circuit. Make sure that the product is connected to an outlet having the same configuration as the plug. No adapter should be used with this product. If the product must be reconnected for use on a different type of electric circuit, the reconnection should be made by qualified service personnel.

*Unauthorized modifications could void the electrical portion of your warranty.* Failure to use a properly grounded outlet for this product or modification of the plug will compromise this important grounding safety feature and may result in electrical shock, electrical fire, or faulty operation of the product.



FOR BEST RESULTS, YOUR Adjustable Base SHOULD BE PLUGGED INTO A SURGE PROTECTOR (not included).

### WARRANTY PRECAUTION:

Do not open control box, motors or wireless remote controls (with the exception of the battery compartment if equipped). The warranty is void if these units are tampered with. Any repair or replacement of Adjustable Base parts must be performed by an authorized technician.

### IN-HOME USE AND HOSPITAL DISCLAIMER:

Your Adjustable Base is strictly designed for in-home use only. It is NOT designed for hospital use and is NOT designed to meet hospital standards. Do not use this base with TENT TYPE oxygen therapy equipment or near explosive gases.

### **WARNING!**

DO NOT USE NEAR PEOPLE USING OR WEARING MEDICAL DEVICES. FOR HOUSEHOLD / RESIDENTIAL USE ONLY. DO NOT USE OUTDOORS.

This product conforms to UL STD 962

### **IMPORTANT SAFETY FEATURES:**

Use this furnishing only for its intended use as described in these instructions. Do not use attachments not recommended by the manufacturer.

If there is an overload weight condition on the head or foot mechanism, the control unit will automatically stop all functions. Once the excess weight is removed the control unit will automatically allow all functions to resume operation after 30 seconds.

As with any product that produces a vibrating motion, it is possible that some pacemakers may interpret this motion as a false sense of movement and/or exercise. This may or may not affect your pacemaker. If you have any concerns, please consult your physician. For more information please contact customer service by calling **800-973-8374**.

### **USER-SERVICEABLE PARTS:**

This product is specifically designed to have no maintenance by you, the user. Therefore, you are encouraged not to open any motors, alter the wiring, adjust, modify or change the structure of the product, as it will void the warranty.

### **POWER RATINGS:**

**INPUT: AC 120V - 60Hz, 1 Amp**

**OUTPUT: DC 32V (4.2Amp)**

The input transformer voltage is AC120V (1.5 Amp) 60HZ, and the output voltage is DC32V (4.2Amp). When there is a short-circuit, the customer should seek professional assistance by calling a licensed electrician or by contacting customer service at **800-973-8374**.

### **SMALL CHILDREN AND PETS WARNING:**

After your Adjustable Base has been unboxed, immediately dispose of packaging as it can smother small children and pets. To avoid injury, children and pets should not be allowed to play on or under the Adjustable Base.

Children should not operate this product without adult supervision. Close supervision is necessary when this furnishing is used by, or near children, invalids, or disabled persons.

### **SAVE THESE INSTRUCTIONS:**

Your Adjustable Base has been designed to provide you with the reliable operation and durability you expect. This product has been inspected and tested prior to shipment.

### **PRODUCT RATINGS**

The lift motor in your Adjustable Base is NOT designed for continuous use. Reliable operation and full life expectancy will be attained as long as the lift motor does not operate more than two (2) minutes over an eighteen (18) minute period, or approximately 10% duty cycle. Any attempt to circumvent or exceed this rating will shorten the life expectancy of this product and may void the warranty. The recommended weight restrictions for your Adjustable Base is up to 850 lbs. total weight, including people and the mattress for all sizes of Adjustable Bases. Lift speed will vary due to weight and mattress configuration, as well as the mattress type. The weight must be evenly distributed across the Adjustable Base. This Product is not designed to support or lift 850 lbs of total weight in the head or foot sections of your Adjustable Base alone, or in any unevenly distributed fashion. Some mattresses are not designed for Adjustable Bases because they do not bend or flex well when adjusted. When using such a mattress with your Adjustable Base the weight limits set forth herein do not apply, as the bending of the mattress requires significant force and puts significant strain on the motors and the Adjustable Base itself.

**Note: Exceeding the recommended weight restrictions could damage your Adjustable Base and void your warranty and using a mattress on top of your Adjustable Base that is not designed for adjustability may also void your warranty.**

For best performance, you should enter and exit the Adjustable Base while it is in the flat or fully lowered position.

**DO NOT SIT ON THE HEAD OR FOOT SECTIONS WHILE IN THE RAISED POSITION.**

### **INTENDED USAGE**

The electric Adjustable Base should be installed with the head board brackets and/or the head of the frame positioned close to a wall.





**Note:** Before discarding any packing materials, check the Adjustable Base carton and verify the following items in the parts list are included:

### PARTS LIST

- A. Wireless Remote Control (1)
- B. Mattress Retainer Bar (4)
- C. Base Legs (4)
- D.\* Retainer Bar Bolt (8)\*
- E.\* Retainer Bar Washer (8)\*
- F. Allen Wrench (1)
- G.\* 3 Outlet Power Strip (1)\*
- H. Qi Charging Pad (1)... optional
- I. Qi Pad Power Supply (1)... optional



\* Attached to base for shipping

**CUSTOMER SERVICE: 800-973-8374**  
service@personalcomfort.com

### IMPORTANT UNPACKING INSTRUCTIONS

To avoid damage to the Adjustable Base, always open the carton while the Adjustable Base is laying in the FLAT position on the floor.

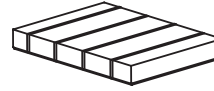

**OPEN FLAT**



### STEP 1

Carefully lift the Adjustable Base unit out of the shipping carton, keeping the unit top side down. For safety reasons, this should be performed by 2 people.

### STEP 2

Assembling Adjustable Base legs: Open the accessories box, take out the 4 legs, and thread them in a clockwise direction into the threaded holes in the frame.

**NOTE:** Tighten the legs securely to the frame. Leave no space between the leg and frame.



### STEP 3

Untie and extend the power cord from the Adjustable Base.

### WARNING:

**POWER CORDS MUST NOT INTERFERE WITH ANY Adjustable Base MECHANISMS.**

### STEP 4

Remove the plastic packaging from the Adjustable Base.

### STEP 5

Carefully rotate the Adjustable Base over to the topside-up position, resting on all four legs.

### ⚠ ATTENTION! Improper handling

### DO NOT

lean the Adjustable Base against the installed legs to flip it over.



### STEP 6

Plug the power cord into a grounded electrical outlet.

**NOTE:** An electrical surge protection unit is recommended (**not included**)

### STEP 7

Briefly activate all functions on the wireless remote control to verify that all of the features are operational. If your Adjustable Base does NOT operate, please refer to the **Troubleshooting** section near the end of this manual.

### STEP 8

Return the base to the flat position and proceed to assemble the **Mattress Retainer Brackets**.

ONLY INSTALL AT CUSTOMER REQUEST. If they find there are issues with the mattress not staying on the base when elevated, then the customer can install the two corner bars at the foot-end of the bed.

### STEP 9

**NOTE:** Use only a manual screwdriver to install the retainer bolts. DO NOT use a power screwdriver to tighten the bolts. DO NOT over tighten the mattress retainer hardware.

Use the retainer bolts (D) and retainer bar washers (E) to fasten the mattress retainer bars (B) to the Adjustable Base.



**NOTE:** If the Adjustable Base is to be set up without a headboard, simply install a mattress on the frame. If a headboard is to be installed, please follow headboard installation instruction.

**ATTENTION:** Failure to follow the proper installation instructions may result in damage to your Adjustable Base.

### STEP 10

Place your mattress on top of your Adjustable Base. Typical Adjustable Base installation is now complete. If the base is equipped with a programmable setting or options, refer to the Remote Control Guide for more information.

### Optional Accessory: Headboard Bracket Installation

#### PARTS LIST

- A. Leg Clamp Bracket (2)
- B. Inner Headboard Bracket (2)
- C. Outer Headboard Bracket (2)
- D. 45 L Bracket Bolt (4)
- E. 40 L Bracket Bolt (8)
- F. 5 / 16 Inch Washer (16)
- G. 5 / 16 Inch Locking Nut (12)
- H. Allen Key (1)
- I. Wrench (1)

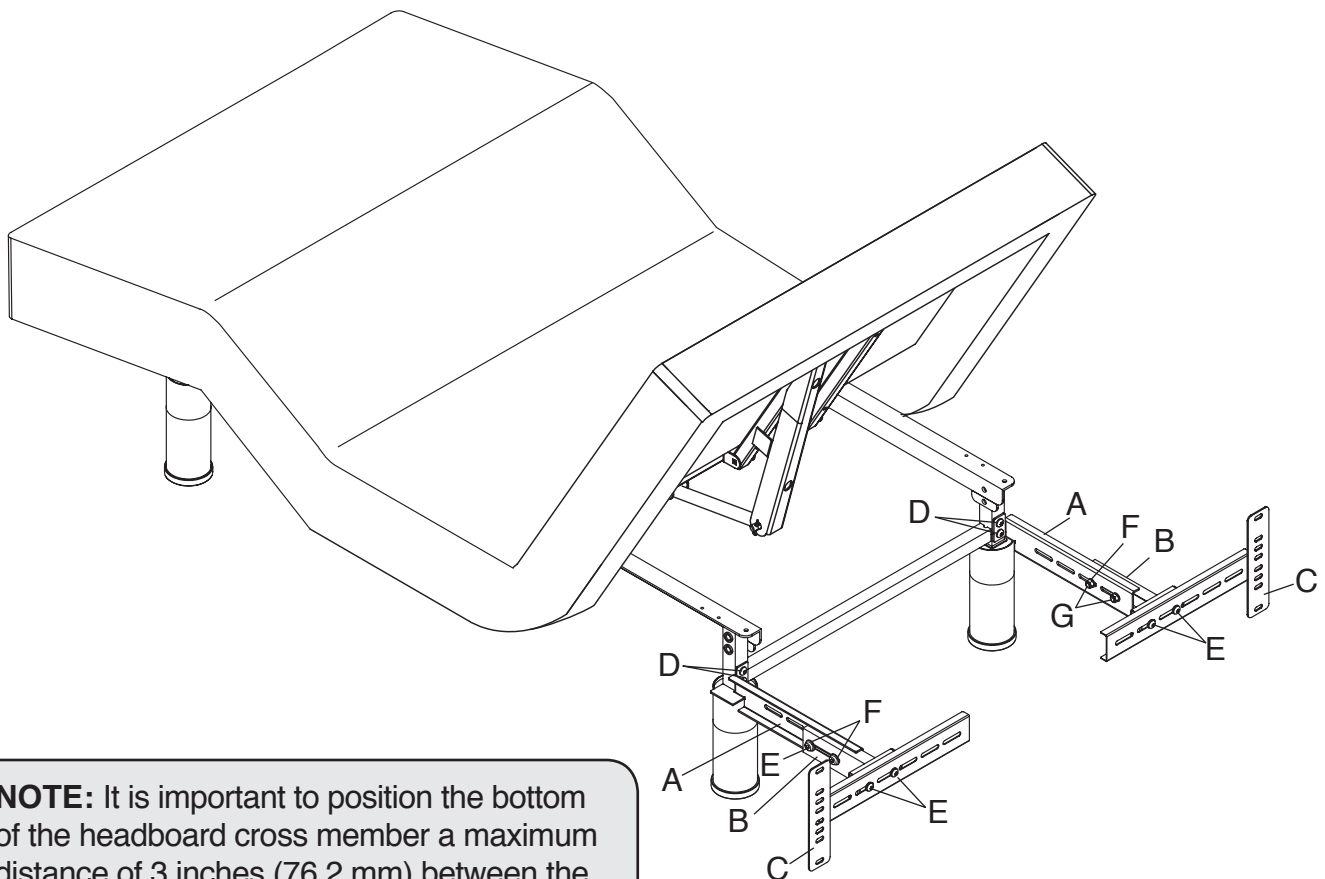
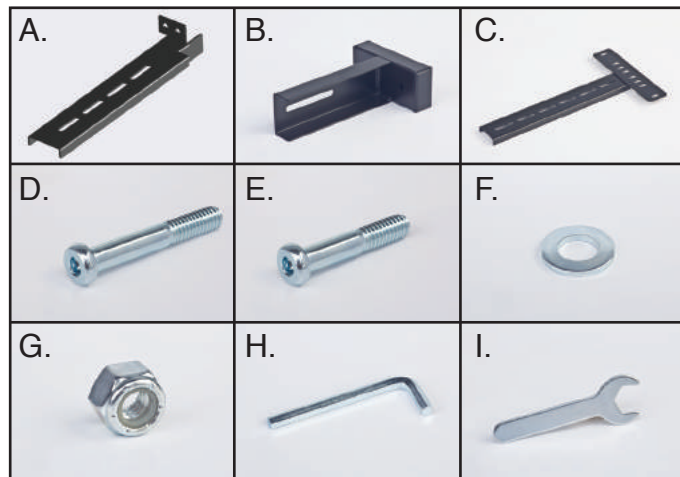

**NOTE:** It is important to position the bottom of the headboard cross member a maximum distance of 3 inches (76.2 mm) between the headboard and the top of the mattress. Do not exceed 3 inches (76.2 mm).

### Headboard Bracket Installation

#### STEP 1

Install the headboard brackets to the Adjustable Base. Place one bracket on the left-hand side of the base and one bracket on the right-hand side of the base.

1. Use the hand control to raise the head of the base in order to gain access to the Adjustable Base.
2. Bolt the Leg Clamp Bracket (A) to the leg using the headboard bracket bolts (D), and the 5/16" lock nut (G).
3. Bolt the inner Headboard Bracket (B) to the Leg Clamp Bracket (A) using the Headboard Bracket Bolts (E), the 5/16" washer (F), and the 5/16" lock nut (G).
4. Place the open side of the outer headboard bracket (C) onto the exposed square tube of the inner head board bracket (B). This will create a tight fit between (B) and (C). Place a Headboard Bracket Bolt (E) with a 5/16 Inch Washer (F) through the Outer Headboard Bracket (C) and into the Inner Headboard Bracket (B). Use a 5/16 Inch Washer (F) and 5/16 Inch Locking Nut (G) and hand tighten to allow for adjustment. Repeat same procedure for opposing side of the Adjustable Base.

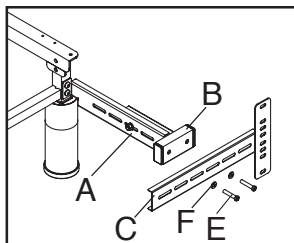
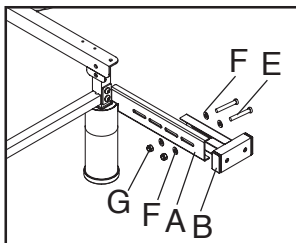
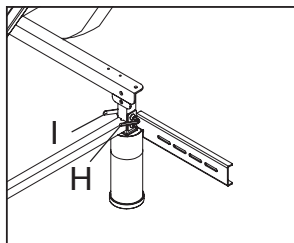
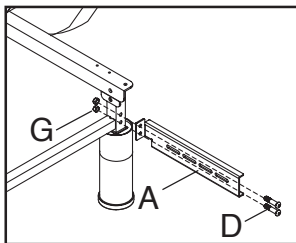

5. Ensure the headboard bracket is assembled a distance of 1.5 (38.1 mm) to 2 inches (50.8 mm) between the edge of the Adjustable Base and the headboard bracket assemblies.
6. Firmly tighten the headboard bolts (not included) to the end of the headboard bracket assembly.

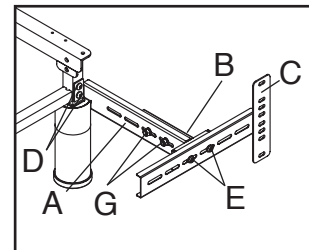
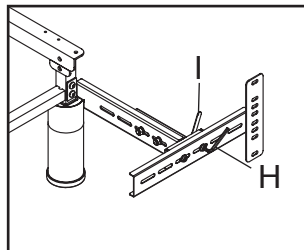

7. Measure the distance of the center to center mounting holes in the headboard.
8. Measure the distance of the center to center mounting holes in the headboard bracket assemblies.
9. If the headboard brackets require adjustments, loosen the bolts that are holding the outer headboard brackets and move them to the necessary distance. Reinstall the bolts and firmly tighten.

#### STEP 2

Place your mattress on top of your Adjustable Base

### How to Download the App Software

#### STEP 1

Please use any of the previously listed devices to log into the APP Store.

#### STEP 2

To control BOTH mattress and base type “**Personal Comfort**” or “**Instant Comfort**” in the search column.

#### STEP 3

Select the appropriate app.

#### STEP 4

Click install to download the app.

**NOTE:** Once the App is installed, when you open the app the Bluetooth Module will connect to your device automatically.

### Select Adjustable Bed Base

Only compatible with Power-Flex™ adjustable bed bases. These adjustable bed bases come with a Bluetooth adaptor that connects to the App.

King and California King bases come in two separate pieces and show up as two separate devices within the App. If you special ordered a Split Queen, it will also be in two separate pieces.

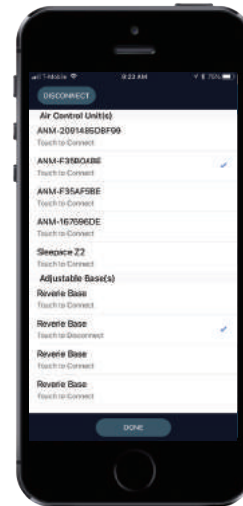

### Test Adjustable Bed Base

Select "Test" to test your adjustable bed base. The head of the base should move up slightly. This will help you determine which side of the bed the device is located.

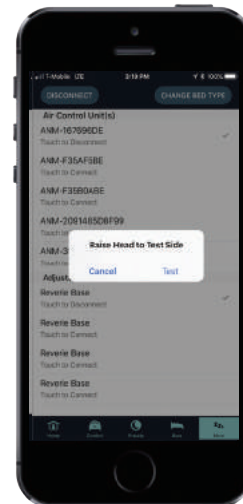

### Choose Side

Stand at the foot of the bed when you start your test. This will help you determine which side of the bed your device is on.

Single bases (Twin, Twin XL, Full/Double, Queen) should select "Single" for App to work properly.

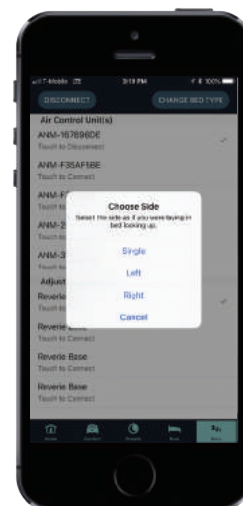

### Sync Bases

**Sync Head and Feet:** For split adjustable bed bases (Split Queen, King and California King) you can choose to sync both sides together so the base functions as one unit.

**Sync Feet Only:** You can also sync only the feet sections of both bases so the feet will raise together and the head will be separate (great for Flex-Head mattresses).

**Do Not Sync:** You can tell the App to not sync any of the bases so the function independently from each other (recommended setting).

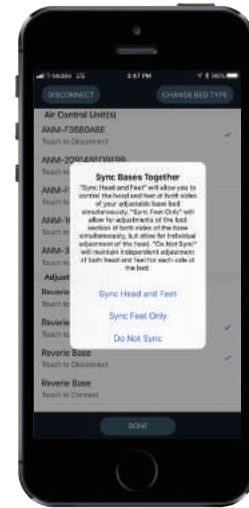

### Adjustable Bed Base

Select "Base" tab at the bottom of the App and you will find several controls for your adjustable bed base. The pillow icon adjusts the head of the bed up and down. The foot icon adjusts the foot of the bed up and down. You can select which side to control by highlighting the "L" or "R" buttons. The "Dual" button allows you to quickly sync the base together to function as one unit. For your convenience we have included three presets positions for your adjustable bed base: flat, zero g and snore.

There are up to four memory settings per side of the base. This is if you want to save that perfect position to memory.

There is a light button for underbed illumination (if applicable). Some Bluetooth devices do not come with underbed lighting.

The massage icon allows you to turn on the head and/or the feet. You also can turn on "Full Body" massage. When you are finished select the "Stop" button.



### Saving an Adjustable Bed Base Setting

Once you have found a setting you would like to save, select "Save" from the memory settings area on the "Base" tab.

### Select a Memory Button

Select a memory button to store your adjustable bed base setting. Select "Cancel" if you would like to go back.



DISPLAY SCREEN

A. RAISE & LOWER HEAD SECTION OF THE BASE

B. RAISE & LOWER FOOT SECTION OF THE BASE

C. HEAD TILT UP/DOWN

D. ZERO GRAVITY

E. ANTI - SNORE

F. RETURN TO FLAT

G. CUSTOM PRESET 1

H. LED LIGHTS ON/OFF

I. CUSTOM PRESET 2

J. MASSAGE

K. HEAD MASSAGE INTENSITY

L. WAVE PATTERN PRESET

M. STOP MASSAGE

N. FOOT MASSAGE INTENSITY

O. MICRO USB CHARGING PORT



### OPERATING INSTRUCTIONS:

**NOTE:**

All screens will timeout after 5 seconds, 15 seconds if screen is auto-refreshing

**HEAD AND FOOT ADJUSTMENTS (A,B)**

- Adjusts the head and foot sections to the desired positions.

**PILLOW TILT (C)**

- Includes a remote-controlled adjustable support section for your head and neck.

**ZERO GRAVITY (D)**

- Allows your legs to be lifted to a position slightly above the chest, which enables blood flow to easily circulate back to the heart, thus reducing stress and fatigue.

**ANTI SNORE (E)**

- Raises the HEAD slightly for easier breathing.

**Adjustable Base “FLAT” BUTTON (F)**

- Levels the Adjustable Base to the flat position when the button is pressed and held for at least 3 seconds.

**NOTE:** Any control button on the remote will interrupt and stop the FLAT, ZERO-G, Anti-Snore and Memory presets 1-2.

**PROGRAMMABLE MEMORY POSITIONS (G,I)**

You can store 2 personalized memory positions.

- To Set a Memory Position: When in desired position, press and hold Memory button for more than 5 seconds until the LED light flashes 3 times to signal Memory position is stored.
- To recall a Memory Position: Press 1 of the 2 presets.

**AMBIENT LIGHTING ON/OFF (H)**

- Toggle the lightbulb button for on/off functions.

**HEAD AND FOOT MASSAGE CONTROLS (K,N)**

- Turns on the corresponding massage unit (starting at intensity 5 of 10)
- Slowly increases or decreases massage intensity. To increase massage intensity, press (+) button. To decrease massage intensity, press (-) button.

**NOTE:** The lowest setting will turn off the corresponding massage unit.

**WAVE MESSAGE PATTERN (L)**

- Turns on both head and foot massage motors to the wave 1 preset.

**MESSAGE STOP BUTTON (M)**

- Press to stop all massage features.

**NOTE:** The massage feature is designed to automatically shut off after 30 minutes of continuous use.

**CHARGING PORT (O)**

- To charge remote, plug in the wall charger and connect to the micro usb port.
- Unplug and plug-in the remote again if you do not see a charging symbol on the screen.
- Flashing LED on remote indicates Low Power status.

### ADDITIONAL REMOTE FEATURES:

- This Adjustable Base uses a Bluetooth® remote control system.
- The included remote is already paired with your Adjustable Base, so should be operational right out of the box. Please test some of the features to ensure functionality.
- Only replacement remote controls require pairing instruction on following pages. If you find that your remote is not paired with the bed, please follow those Bluetooth pairing instructions.

**NOTE:** This Adjustable Base may have minor intermittent performance due to RF Interference. This is a normal operation of the Adjustable Base and is not a defect.

- The buttons are back-lit, when a button is pressed, to aid the visibility of the remote in low light environments.
- Customers can control the remote without facing the receiver (best transmission range is within 30 feet or 10 meters)
- The remote is equipped with a lithium-ion battery that can be recharged anytime with the included Micro USB wall charger adapter.
- Please fully charge your remote before operating for the first time.
- When remote is fully charged, the charging symbol will disappear.

### SAFETY:

- If there is an overload weight condition on the head or foot mechanism, the control unit will automatically stop all functions.

- The input transformer voltage is AC 120V 60 HZ, the output voltage is DC 36V 4.2A. When there is a short circuit, a fuse on the transformer will be blown in order to protect the electrical equipment.

**ATTENTION:** When the above situation occurs, the customer **MUST** seek professional assistance.

### NOTICE:

**The changes or modifications not expressly approved by the party responsible for compliance could void the user's authority to operate the equipment.**

#### REMOTE LOCKOUT FEATURE (D,M)

- We created the remote lockout feature to help owners prevent unintended use of the base.

#### Activating Remote Lockout

- At the same time, press and hold the ZERO G and STOP buttons for 3 seconds. The white LED will flash twice to indicate activation. Pressing any buttons on the remote while in lockout mode will result in no movement from the Adjustable Base.

#### Deactivating Remote Lockout

- Same method, press and hold the ZERO G and STOP buttons at the same time for 3 seconds. The white LED will flash twice to indicate deactivation. The remote and Adjustable Base will work normally.

### CONNECTING ONE BED

[does not include KING or SPLIT KING bed sizes]

#### STEP 1

Hold Lightbulb button for 3 seconds to start searching.

#### STEP 2

The remote will only detect one bed and automatically connect.

### CONNECTING ONE BED

[KING or SPLIT KING only]

#### STEP 1

Hold Lightbulb button for 3 seconds to start searching.

#### STEP 2A

[Select KING]

- Scroll using any of the up/down buttons H/L/F. Select by single-pressing lightbulb button.
- If it detects only 2 control boxes then will automatically connect with both control boxes on your bed.
- If it detects more than 2 control boxes, the LED display will show a list of all available control boxes within range [this usually means you have more than one bed in your house]
- Select desired control boxes you want to connect.

#### STEP 2B

[Select SPLIT KING]

- Scroll using any of the up/down buttons H/L/F. Select by single-pressing lightbulb button.
- When you choose SPLIT KING, will be asked if want to connect to both sides of bed?
- Select YES and will automatically connect with both sides.
- Select NO, then LED display will show a list of available beds within range.
- Select the desired beds you want to connect.

### CONNECTING TWO BEDS

[OTHER - connecting two specific beds]

#### STEP 2C

[Select OTHER]

- After selecting OTHER you will be shown a list of all available beds and asked to select the beds you wish to connect [remote can show up to 20 beds]
- Select any two beds you wish to connect by single-pressing the lightbulb button.

**NOTE:** If it cannot detect any beds then will say NO BED FOUND.

**NOTE:**  
Please remember to recycle all electronics.

### ADDITIONAL TIPS FOR PAIRING TWO REMOTES

[for KING, SPLIT KING or two beds]



Our remote and Bluetooth technology allows for pairing/connecting two remotes with each side of the bed so each remote can control both sides of bed.



Pair/Connect one remote with both sides of the bed, then wait for that remote to enter sleep mode and pair/connect the other remote with both sides of bed.



If two remotes are connected to one bed, in order to actively use one of the remotes to control the bed you must make sure the other remote is in sleep mode. Waking up other remote will result in a disconnection from the control unit and the remote will show “No Bed Paired”.

**NOTE:**

This applies to the king bed situation, where two remotes are connected to both sides of the bed.

### IMPORTANT NOTE:

- To comply with the FCC RF exposure compliance requirements, no change to the antenna or the device is permitted. Any change to the antenna or the device could result in the device exceeding the RF exposure requirements and void user's authority to operate the device.*

**THIS DEVICE COMPLIES WITH PART 15 OF THE FCC RULES. OPERATION IS SUBJECT TO THE FOLLOWING TWO CONDITIONS: (1) THIS DEVICE MAY NOT CAUSE HARMFUL INTERFERENCE (2) THIS DEVICE MUST ACCEPT ANY INTERFERENCE RECEIVED, INCLUDING INTERFERENCE THAT MAY CAUSE UNDESIRED OPERATION.**



**NOTE:**  
 1. Scroll using head/foot.  
 2. Press light icon to select.



Hold down the light icon to access the B.T setup

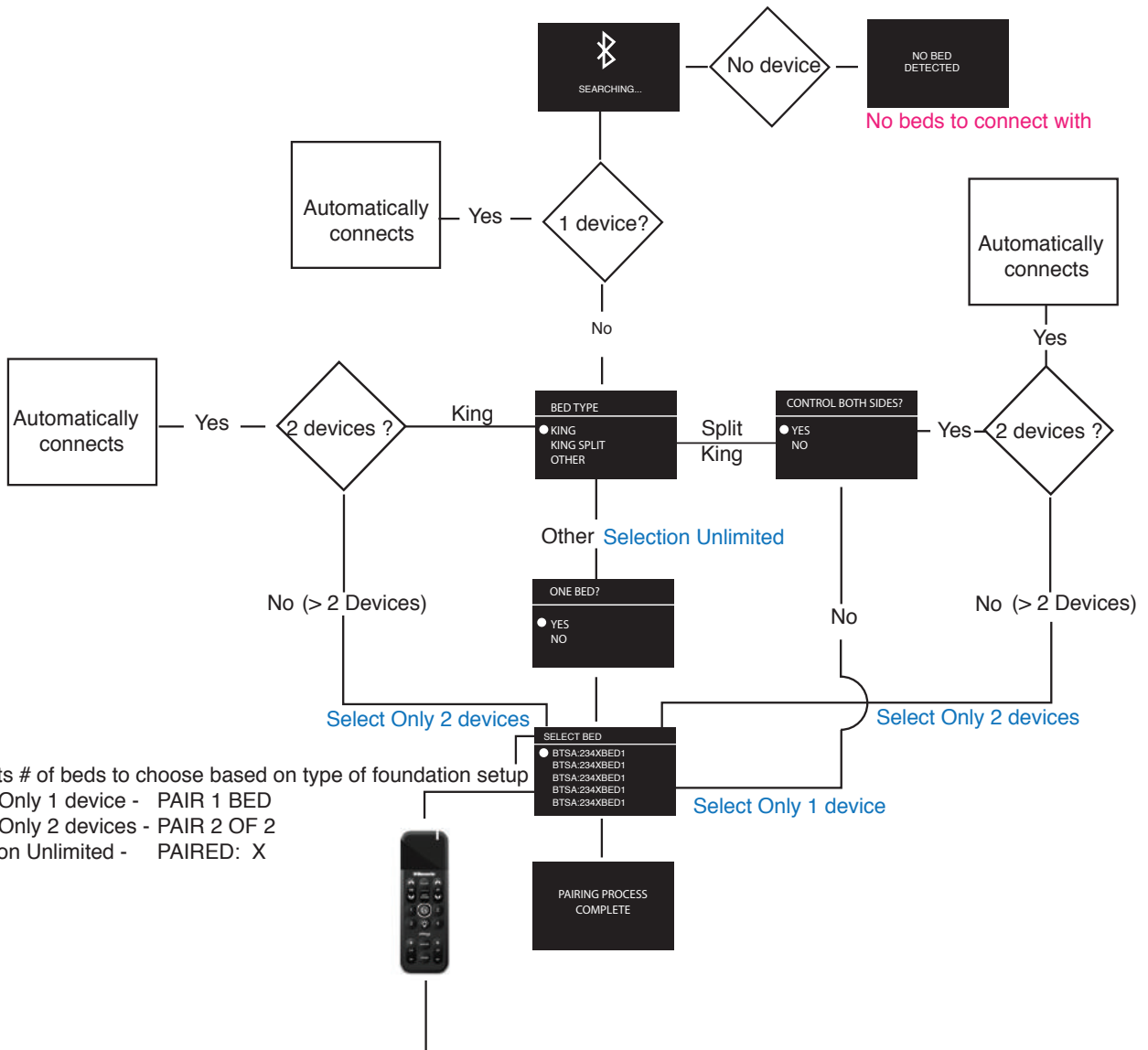

Instructs # of beds to choose based on type of foundation setup  
 Select Only 1 device - PAIR 1 BED  
 Select Only 2 devices - PAIR 2 OF 2  
 Selection Unlimited - PAIRED: X

Press the "Zero G" button within the B.T menu to identify the bed.  
 The foundation's night light and PLC light will activate and the  
 massage will turn on for 2 seconds and cut off

Note: Dot indicates selected bed.

### Head Tilt

- This model provides a remote controlled adjustable Head Tilt support function for your head/neck. Range of motion up to 30 degrees.



### LED Strips

- This model comes equipped with [2] LED strips placed under the bed to provide adequate ambient lighting and can be controlled with your remote [on/off].

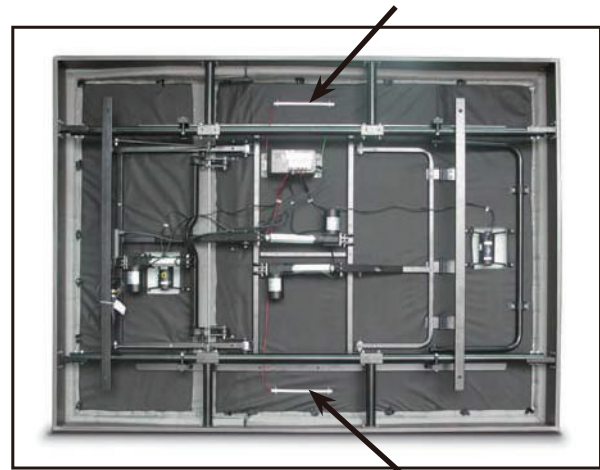

### Qi Pad

- The charging pad is an optional item with 8/9T Adjustable Base models and may not be included with this base.
- As instructed in the remote operations section above, we recommend charging the remote with the included micro usb wall charger.
- **The remote does NOT have wireless charging capability. You must use the USB ports to charge the remote.**
- The charging pad can be used to wirelessly charge Qi compliant devices only (such as certain Android phones). Follow the directions on your device for wireless charging. Our charging point is located in the direct center of the pad.
- The charging pad includes (2) USB ports that can be used to charge devices, such as the remote control, using your own compatible USB cable.

**CUSTOMER SERVICE: 800-973-8374**

[service@personalcomfort.com](mailto:service@personalcomfort.com)

In the Event the Adjustable Base fails to operate, investigate the symptoms and possible solutions provided in the chart below:

<p>Remote Control appears to be operable but will not activate the bed.</p>	<ul style="list-style-type: none"> <li>• Verify the power cord is plugged into a working, grounded electrical outlet. A <i>grounded, electrical surge protection device is recommended</i>. Test the outlet by plugging in another working appliance.</li> </ul>
<p>No features of the Adjustable Base will activate.</p>	<ul style="list-style-type: none"> <li>• Make sure remote is paired to the bed.</li> <li>• Your electrical circuit breaker may be tripped.</li> <li>• The surge protection device of electrical outlet is defective, test the outlet by plugging in another device.</li> </ul>
<p>Remote control LED will not illuminate.</p>	<ul style="list-style-type: none"> <li>• Charge the remote with the provided micro usb wall adapter charger.</li> </ul>
<p>Head or foot section will elevate but will not return to the horizontal (flat) position.</p>	<ul style="list-style-type: none"> <li>• The Adjustable Base mechanism may be obstructed. Elevate the Adjustable Base and check for an obstruction. Remove the obstruction.</li> <li>• The head section may be too close to the wall. The headboard may be too close to the edge of the mattress. Verify a 1.5" (38.1mm) to 2" (50.8mm) distance is between the headboard brackets and the mattress. Adjust if required.</li> </ul>
<p>Battery Mode Operation</p>	<ul style="list-style-type: none"> <li>• Head/Foot/Pillow actuators will move slow and only one actuator will move at a time.</li> <li>• Massage feature will not be enabled while running on battery power.</li> <li>• While on battery power, the remote should show "Battery Power Warning" on the screen.</li> <li>• Press LED button on control box for 3 seconds to completely shut off the power [will save battery life].</li> <li>• In case of power failure or manual unplugging from power supply, the bed will continue to run on battery power.</li> </ul>





<p>Remote showing “No Bed Paired”</p>	<ul style="list-style-type: none"> <li>• Allow the remote to go back to sleep by setting down, check if its connected after 3 minutes.</li> <li>• If not resolved, go through the pairing process again.</li> </ul>
<p>Distorted image on the remote LED screen.</p>	<ul style="list-style-type: none"> <li>• Let the remote go back to sleep and wake it up again. Repeat this multiple times. If problem persists, contact customer service.</li> </ul>
<p>All functions stopped working due to overload condition.</p>	<ul style="list-style-type: none"> <li>• Remove the load and reset again by putting the bed to flat position and then moving it all the way to maximum position.</li> </ul>
<p>Head or Foot Lift function has minor interference during operation.</p>	<ul style="list-style-type: none"> <li>• Make sure that you are following the duty cycle of the motors (do not operate more than three (3) minutes over a thirty (30) minute period, approximately 10% duty cycle).</li> <li>• Press the lift buttons squarely &amp; accurately.</li> </ul>
<p>Head Tilt is not performing normally.</p>	<ul style="list-style-type: none"> <li>• Make sure pressing the correct button and good batteries are in the remote.</li> <li>• Check for obstructions.</li> </ul>
<p>Excessive massage motor noise.</p>	<ul style="list-style-type: none"> <li>• If the bed is located on hard surface flooring, place carpet pieces.</li> <li>• Elevate the head or foot section a short distance (with the hand control) to realign the lift/lower mechanisms with the bed support platform.</li> <li>• Verify that the bed is not positioned against a wall, nightstand, or other object that may cause the vibration or noise.</li> <li>• If this base is installed over a bed frame, verify the massage motors are not causing the bed frame (or bed frame components) to vibrate.</li> <li>• Verify that the headboard attachment hardware is firmly tightened.</li> </ul>



<p>Lift Motor Noise</p>	<ul style="list-style-type: none"> <li>Actuators make noise at startup. We don't want to overload the system so we provide a soft start which ramps up the current and makes some initial noise, which does not indicate any defect.</li> </ul>
<p>Remote readout doesn't match actual bed position.</p>	<ul style="list-style-type: none"> <li>Recalibrate by pressing FLAT on the remote, then lift all sections to maximum position until it shows 100% on the remote screen.</li> </ul>
<p>Remote Lockout Feature not working</p>	<ul style="list-style-type: none"> <li>Make sure you are correctly pressing the ZERO G and STOP buttons at same time.</li> <li>Verify that the remote has battery power.</li> <li>Make sure there are no other devices causing RF interference with the remote.</li> <li>If cannot determine then please call customer service.</li> </ul>
<p>Noise Under Base</p>	<ul style="list-style-type: none"> <li>If there is any noise in the initial part of the head lift, shift the bed up/down to avoid the lift motor from hitting any structure under the base.</li> </ul>
<p>App Won't Connect to Base</p>	<ul style="list-style-type: none"> <li>This happens when the wireless remotes have already been paired with the base.</li> <li>Allow the remote to go back to sleep by setting down, check to see if the display has gone blank after 3 minutes.</li> <li>Once the remote has gone to sleep, begin the pairing process within the App.</li> </ul>



## 20 Year Limited Warranty for Reverie Adjustable Bases

Ascion, L.L.C. d/b/a Reverie (hereinafter referred to as “Reverie”) warrants to the end user (hereinafter referred to as “Purchaser”) that during the twenty (20) year term of this Limited Warranty, Reverie will, at its sole discretion and option, repair or replace Purchaser’s motorized bed frame or motorized bed foundation parts (hereinafter referred to as “adjustable bed” or “adjustable beds”) that are found to be defective due to faulty workmanship or materials, subject to the limitations set forth herein.

This Limited Warranty begins on the “warranty commencement date” which is the date of purchase for new unused adjustable beds and the date of manufacture for adjustable beds that have been used as floor or display models. Thus, on a floor model adjustable bed, the warranty is a portion of the 20-year Limited Warranty. If original proof of purchase is not provided by Purchaser, Reverie reserves the right to determine that the adjustable bed is not covered by this Limited Warranty or to use the manufacturing date as the warranty commencement date. This Limited Warranty extends only to the original Purchaser and may not be transferred.

### YEAR 1: FULL COVERAGE OF PARTS AND LABOR

Upon receiving reasonable notice during the first year from the warranty commencement date, Reverie will send replacement parts (at no cost to the Purchaser) for any defective adjustable bed part to the Purchaser, and Reverie will pay all pre-authorized labor and transportation costs associated with the repair or replacement of any parts Reverie determines to be defective. This one (1) year Limited Warranty shall not apply if Purchaser does not return any and all defective parts to Reverie within 15 days of Purchaser’s receipt of replacement part(s).

### YEARS 2-5: FULL COVERAGE OF PARTS ONLY

Upon receiving reasonable written notice at any point in time that is more than one (1) year and up to five (5) years from the warranty commencement date, Reverie will offer replacement parts for any defective adjustable bed part to the Purchaser. This four (4) year Limited Warranty shall not apply if Purchaser does not return any and all defective parts to Reverie within 15 days of Purchaser’s receipt of replacement part. Purchaser shall bear all service, transportation, labor and shipping costs related to the delivery and/or replacement of the defective part.

## YEARS 6-20: FULL COVERAGE OF FRAME ONLY

Upon receiving reasonable written notice at any point in time that is more than five (5) years and up to twenty (20) years from the warranty commencement date, Reverie will offer replacement parts for any mechanical part of the frame found to be defective. Electronics, electrical components, drive motors and massage motors are excluded from this Limited Warranty. Purchaser shall bear all service, transportation, labor and shipping costs related to the delivery and/or replacement of the defective part.

## ADDITIONAL TERMS AND CONDITIONS

This Limited Warranty does not apply: (a) to any damage caused by the Purchaser; (b) if there has been any unauthorized repair or replacement of adjustable bed parts; (c) if the adjustable bed has been mishandled (whether in transit or by other means), subjected to physical or electrical abuse or misuse, or otherwise operated in any way inconsistent with the operation and maintenance procedures outlined in the Owner's Manual, this Limited Warranty, and any other applicable document published or approved by Reverie; (d) to damage to mattresses, fabric, cables, electrical cords or items supplied by any Reseller of the adjustable bed, (contact the Reseller or other relevant party for warranty information on these items.); (e) if there have been any unnecessary service calls, including costs for in-home service calls solely for the purpose of educating the consumer about the adjustable bed or for finding an unsatisfactory power connection.

Depending on the mattress used by the Purchaser, Purchaser may experience varying degrees of shifting of their mattress. Such shifting shall not be considered a defect under this Limited Warranty. Should shifting persist, please install the supplied retainer bars.

Repairs to or replacement of the adjustable bed or its components under the terms of this Limited Warranty will apply to the original warranty period and will not serve to extend such period.

The decision to repair or to replace defective parts under this Limited Warranty shall be made exclusively by Reverie in its sole and exclusive discretion.

REPAIR OR REPLACEMENT SHALL BE THE SOLE REMEDY OF THE PURCHASER. THERE SHALL BE NO LIABILITY ON THE PART OF REVERIE AND THEIR RESPECTIVE PARENTS, SUBSIDIARIES, DIVISIONS OR AFFILIATES FOR ANY SPECIAL, INDIRECT, INCIDENTAL, OR CONSEQUENTIAL DAMAGES OR FOR ANY OTHER DAMAGE, CLAIM, OR LOSS NOT EXPRESSLY COVERED BY THE TERMS OF THIS LIMITED WARRANTY.

This Limited Warranty does not include reimbursement for inconvenience, removal, installation, setup time, loss of use, shipping, or any other costs or expenses.

UNLESS OTHERWISE EXPRESSLY STATED IN THIS DOCUMENT, REVERIE AND THEIR RESPECTIVE PARENTS, SUBSIDIARIES, DIVISIONS AND AFFILIATES EXPRESSLY DISCLAIM ANY OTHER WARRANTY WHATSOEVER, EXPRESS OR IMPLIED, INCLUDING BUT NOT LIMITED TO IMPLIED WARRANTIES OF MERCHANTABILITY, FITNESS FOR A PARTICULAR PURPOSE, AND FREEDOM FROM DEFECTS AND WORKMANSHIP.

Some states may not allow the exclusion or limitation of incidental or consequential damages in some circumstances, so the above limitation or exclusion may not apply to every Purchaser. This Limited Warranty gives the Purchaser specific legal rights, and the Purchaser may also have other rights, which may vary from state to state. This Limited Warranty is valid in all states of the United States except Alaska, Hawaii and Puerto Rico.

If you experience any trouble with your adjustable bed during the warranty period, please consult the troubleshooting guide provided with your adjustable bed and online (if applicable), or the troubleshooting video provided online (if applicable). If problems persist after following these instructions, please call:

**1-800-973-8374**

[service@personalcomfortbed.com](mailto:service@personalcomfortbed.com)

Please have your receipt ready and available.

Thank you and enjoy your Adjustable Base.

**Register Online.**

**Register Online.** For easy registration of your warranty visit [www.reverie.com](http://www.reverie.com)

Please prepare a digital copy of your proof of purchase (invoice or sales receipt) when registering online. You may be required to provide the Serial Number for registration, you can find it one the Law Tags attached to the base.

**Manufactured by Reverie®**

Warranty and Service:

**800-973-8374**

**service@personalcomfortbed.com**



Name \_\_\_\_\_

Phone \_\_\_\_\_

Address \_\_\_\_\_

City \_\_\_\_\_ State/Province \_\_\_\_\_ Zip/Postal Code \_\_\_\_\_

Purchase Date \_\_\_\_\_

Bed Serial Number \_\_\_\_\_

Email Address \_\_\_\_\_



Lined area for notes with a dark blue bar at the bottom.

# POWER-FLEX™ 4

Power-Flex™ Adjustable Base built by:



**CUSTOMER SERVICE: 800-973-8374**

[service@personalcomfort.com](mailto:service@personalcomfort.com)