

POWER-FLEX™ 3

Owner's Manual and Reference Guide



Power-Flex™ Adjustable Base built by:



POWER-FLEX™ 3

Power-Flex™ 3 Adjustable Base

Table of Contents

Safety Precautions.....	3
Parts List.....	9
Frame Assembly Instructions	10
Downloadable App Operation	14
Wireless Remote Control.....	19
Remote Control Operation Guide.....	20
Replacement Remote Control Programming.....	22
Remote Control Emergency Power Down Feature.....	24
Troubleshooting.....	25
Warranty.....	27

Warranty Information: Please see the warranty that came with your product. Power-Flex™ 3 Adjustable Base



CUSTOMER SERVICE: 800-973-8374
SERVICE@POWERFLEXBASE.COM

SAFETY PRECAUTIONS

**WARNING! IMPORTANT SAFETY INSTRUCTIONS.
PLEASE READ THESE INSTRUCTIONS
THOROUGHLY BEFORE USING THIS PRODUCT.
SAVE THESE INSTRUCTIONS!**

When using an electrical furnishing basic precautions should always be followed, including the following:

READ ALL INSTRUCTIONS BEFORE USING (THIS FURNISHING)

DANGER: To reduce the risk of electric shock:
Always unplug this furnishing from the electrical outlet before cleaning.

WARNING:
To reduce the risk of burns, fire, electric shock, or injury to persons:

- Unplug from outlet before putting on or taking off parts.
- Close supervision is necessary when this furnishing is used by or near children, invalids or disabled persons.
- Use this furnishing only for its intended use as described in these instructions. Do not use attachments not recommended by the manufacturer.
- Never operate this furnishing if it has a damaged cord or plug, or if it is not working properly, dropped or damaged, or dropped into the water. Return the furnishing to a service center for examination and repair.
- Keep the cord away from heated surfaces.
- Never operate the furnishing with the air openings blocked. Keep the air openings free of lint, hair and the like.
- Never drop or insert any object into any opening.
- Do not use outdoors.
- Do not operate where aerosol (spray) products are being used or where oxygen is being administered.
- To disconnect, turn all controls to the off position, then remove plug from outlet.

WARNING: Risk of Injury:
Keep children away from extended foot support (or other similar parts).

WARNING: Risk of electric shock:
Connect this furnishing to a properly grounded outlet only.
See Grounding instructions.

GROUNDING INSTRUCTIONS:

This product must be grounded. If it should malfunction or breakdown, grounding provides a path of least resistance for electric current to reduce the risk of electric shock. This product is equipped with a cord having an equipment-grounding conductor and a grounding plug. The plug must be plugged into an appropriate outlet that is properly installed and grounded in accordance with all local codes and ordinances.

DANGER:
Improper connection of the equipment-grounding conductor can result in a risk of electric shock. Check with a qualified electrician or serviceman if you are in doubt as to whether the product is properly grounded.

Do not modify the plug provided with the product. If it will not fit the outlet, have a proper outlet installed by a qualified electrician.

SAVE THESE INSTRUCTIONS!

CUSTOMER SERVICE: 800-973-8374
SERVICE@POWERFLEXBASE.COM

This product is for use on a standard 120-volt circuit, and has a grounding plug that looks like the plug illustrated in photo A (see Figure). A temporary adapter that looks like the adapter illustrated in photo B and C can be used to connect this plug to a 2-pole receptacle as shown in photo B if a properly grounded outlet is not available. The temporary adapter should be used only until a properly grounded outlet (photo A) can be installed by a qualified electrician. The green colored rigid ear, lug or the like extending from the adapter must be connected to a permanent ground such as a properly grounded outlet box cover. Whenever the adapter is used, it must be held in place by a metal screw.

This product is for use on a circuit having a standard rating of 120 volts and is factory equipped with a specific electric cord and plug to permit connection to a proper electric circuit. Make sure that the product is connected to an outlet having the same configuration as the plug. No adapter should be used with this product. If the product must be reconnected for use on a different type of electric circuit, the reconnection should be made by qualified service personnel.

Unauthorized modifications could void the electrical portion of your warranty. Failure to use a properly grounded outlet for this product or modification of the plug will compromise this important grounding safety feature and may result in electrical shock, electrical fire, or faulty operation of the product.



FOR BEST RESULTS, YOUR ADJUSTABLE BASE SHOULD BE PLUGGED INTO A SURGE PROTECTOR (not included).

WARRANTY PRECAUTION:

Do not open control box, motors or wireless remote controls (with the exception of the battery compartment if equipped). The warranty is void if these units are tampered with. Any repair or replacement of Adjustable Base parts must be performed by an authorized technician.

IN-HOME USE AND HOSPITAL DISCLAIMER:

Your Adjustable Base is strictly designed for in-home use only. It is NOT designed for hospital use and is NOT designed to meet hospital standards. Do not use this base with TENT TYPE oxygen therapy equipment or near explosive gases.

WARNING!

DO NOT USE NEAR PEOPLE USING OR WEARING MEDICAL DEVICES. FOR HOUSEHOLD / RESIDENTIAL USE ONLY. DO NOT USE OUTDOORS.

This product conforms to UL STD 962

IMPORTANT SAFETY FEATURES:

Use this furnishing only for its intended use as described in these instructions. Do not use attachments not recommended by the manufacturer.

If there is an overload weight condition on the head or foot mechanism, the control unit will automatically stop all functions. Once the excess weight is removed the control unit will automatically allow all functions to resume operation after 30 seconds.

As with any product that produces a vibrating motion, it is possible that some pacemakers may interpret this motion as a false sense of movement and/or exercise. This may or may not affect your pacemaker. If you have any concerns, please consult your physician. For more information please contact customer service by calling **800-973-8374**.

USER-SERVICEABLE PARTS:

This product is specifically designed to have no maintenance by you, the user. Therefore, you are encouraged not to open any motors, alter the wiring, adjust, modify or change the structure of the product, as it will void the warranty.

POWER RATINGS:

INPUT: AC 120V - 60Hz, 1Amp

OUTPUT: DC 24V-3A

FUSE: 1.5A 250V

The input transformer voltage is AC120V (1.5 Amp) 60HZ, and the output voltage is DC24V (3Amp). When there is a short-circuit, a fuse on the transformer will be blown in order to protect the electrical equipment (Fuse: 1.5A). Should the above situation occur, the customer should seek professional assistance by calling a licensed electrician or by contacting customer service at **800-973-8374**.

CUSTOMER SERVICE: 800-973-8374
SERVICE@POWERFLEXBASE.COM

SMALL CHILDREN AND PETS WARNING:

After your Power-Flex™ 3 Adjustable Base has been unboxed, immediately dispose of packaging as it can smother small children and pets. To avoid injury, children and pets should not be allowed to play on or under the Adjustable Base.

Children should not operate this product without adult supervision. Close supervision is necessary when this furnishing is used by, or near children, invalids, or disabled persons.

SAVE THESE INSTRUCTIONS:

Your Power-Flex™ 3 Adjustable Base has been designed to provide you with the reliable operation and durability you expect. This product has been inspected and tested prior to shipment.

RADIO FREQUENCY IS 433.92 MHZ

FCC COMPLIANCE

This device complies with part 15 of the FCC Rules. Operation is subject to the following two conditions: (1) This device may not cause harmful interference, and (2) this device must accept any interference received, including interference that may cause undesired operation.

To comply with the FCC RF exposure compliance requirements, no change to the antenna or the device is permitted. Any change to the antenna or the device could result in the device exceeding the RF exposure requirements and void the user's authority to operate the device.

PRODUCT RATINGS

The lift motor in your **Power-Flex™ 3** Adjustable Base is NOT designed for continuous use. Reliable operation and full life expectancy will be attained as long as the lift motor does not operate more than two (2) minutes over an eighteen (18) minute period, or approximately 10% duty cycle. Any attempt to circumvent or exceed this rating will shorten the life expectancy of this product and may void the warranty. The recommended weight restrictions for your **Power-Flex™ 3** Adjustable Base is up to 850 lbs. total weight, including people and the mattress for all sizes of adjustable bases. Lift speed will vary due to weight and mattress configuration, as well as the mattress type. The weight must be evenly distributed across the Adjustable Base. This Product is not designed to support or lift 850 lbs of total weight in the head or foot sections of your **Power-Flex™ 3** Adjustable Base alone, or in any unevenly distributed fashion. Some mattresses are not designed for adjustable bases because they do not bend or flex well when adjusted. When using such a mattress with your **Power-Flex™ 3** Adjustable Base the weight limits set forth herein do not apply, as the bending of the mattress requires significant force and puts significant strain on the motors and the Adjustable Base itself.

CUSTOMER SERVICE: 800-973-8374
SERVICE@POWERFLEXBASE.COM

Note: Exceeding the recommended weight restrictions could damage your Adjustable Base and void your warranty and using a mattress on top of your Adjustable Base that is not designed for adjustability may also void your warranty.

For best performance, you should enter and exit the Adjustable Base while it is in the flat or fully lowered position.

DO NOT SIT ON THE HEAD OR FOOT SECTIONS WHILE IN THE RAISED POSITION.

INTENDED USAGE

The electric Adjustable Base should be installed with the head board brackets and/or the head of the frame positioned close to a wall.

CUSTOMER SERVICE: 800-973-8374
SERVICE@POWERFLEXBASE.COM

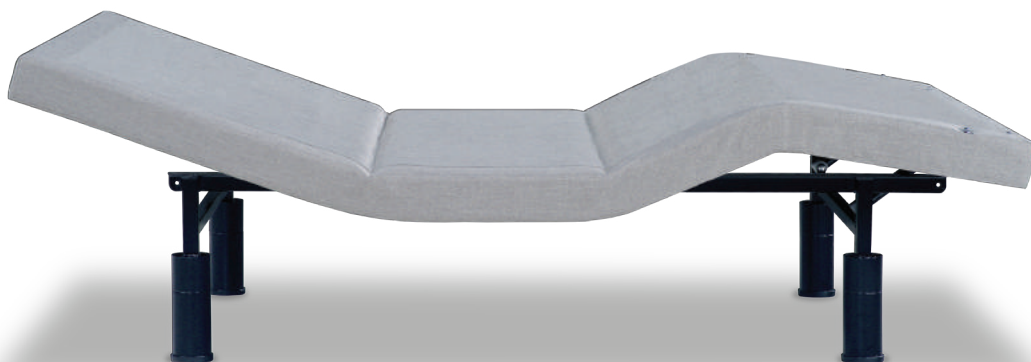

Note: Before discarding any packing materials, check the Adjustable Base carton and verify the following items in the parts list are included:

Note: Adjustable Base may come in different fabric colors depending on region/retailer.

PARTS LIST

A. Wireless Remote Control (1) and
Three (3) AAA Batteries

B. 4 Corner Mattress Retainer Bar (4)

C. Base Legs (4)

D. Retainer Bar Bolt (8)

E. Allen Wrench (1)

F. 9-Volt Batteries (2)

G. Retainer Bar Plate (8)

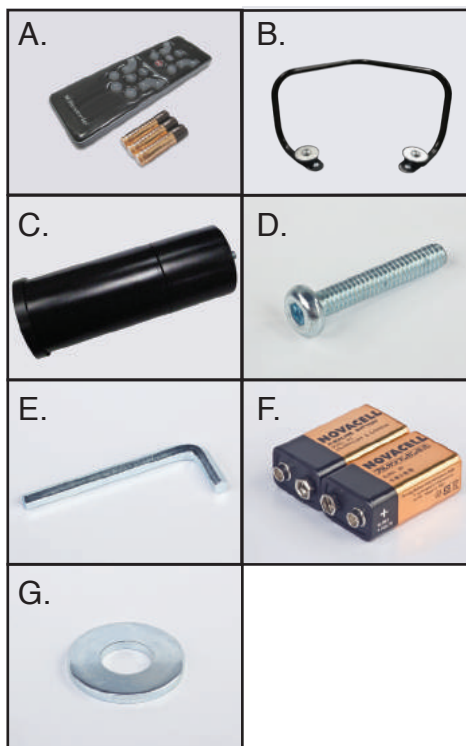

IMPORTANT UNPACKING INSTRUCTIONS

To avoid damage to the Adjustable Base, always open the carton while the Adjustable Base is laying in the FLAT position on the floor.

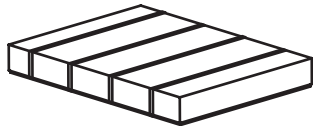

OPEN FLAT



STEP 1

Carefully lift the Adjustable Base unit out of the shipping carton, keeping the unit top side down. For safety reasons, this should be performed by 2 people.



STEP 2

Assembling Adjustable Base legs: Open the accessories box, take out the 4 legs, and thread them in a clockwise direction into the threaded holes in the frame.

NOTE: Tighten the legs securely to the frame. Leave no space between the leg and frame.



STEP 3

Extend the power cord from the frame.

WARNING:
POWER CORDS MUST NOT INTERFERE WITH ANY Adjustable Base MECHANISMS.

STEP 4

Remove the plastic packaging from the Adjustable Base.

STEP 5

Carefully rotate the Adjustable Base over the topside up position.

ATTENTION! Improper handling

DO NOT

lean the Adjustable Base against the installed legs to flip it over.



STEP 6

Plug the power cord into a grounded electrical outlet.

NOTE: An electrical surge protection unit is recommended (**not included**)

STEP 7

Install the batteries in your wireless remote control. Briefly activate all functions on the wireless remote control to verify that all of the features are operational. If your Power-Flex™ 3 Adjustable Base does NOT operate, please refer to the **Troubleshooting** section beginning on **page 25** of this manual.

CUSTOMER SERVICE: 800-973-8374
SERVICE@POWERFLEXBASE.COM

STEP 8

NOTE: Use only a manual screwdriver to install the retainer bolts. DO NOT use a power screwdriver to tighten the bolts. DO NOT over tighten the mattress retainer hardware.

Use the Retainer Bolts (F) and Retainer Bar Plate (I) to fasten the Mattress Retainer Bracket (B) to the Adjustable Base.



STEP 9

Place your mattress on top of your Adjustable Base. Typical **Power-Flex™ 3** Adjustable Base installation is now complete. If the base is equipped with a programmable setting or options, refer to the Remote Control Guide for more information.

Optional Parts List for Headboard Bracket Installation

PARTS LIST (Sold Separately)

- A. Leg Clamp Bracket (2)
- B. Inner Headboard Bracket (2)
- C. Outer Headboard Bracket (2)
- D. 45 L Bracket Bolt (4)
- E. 40 L Bracket Bolt (8)
- F. 5 / 16 Inch Washer (16)
- G. 5 / 16 Inch Locking Nut (12)
- H. Allen Key (1)
- I. Wrench (1)

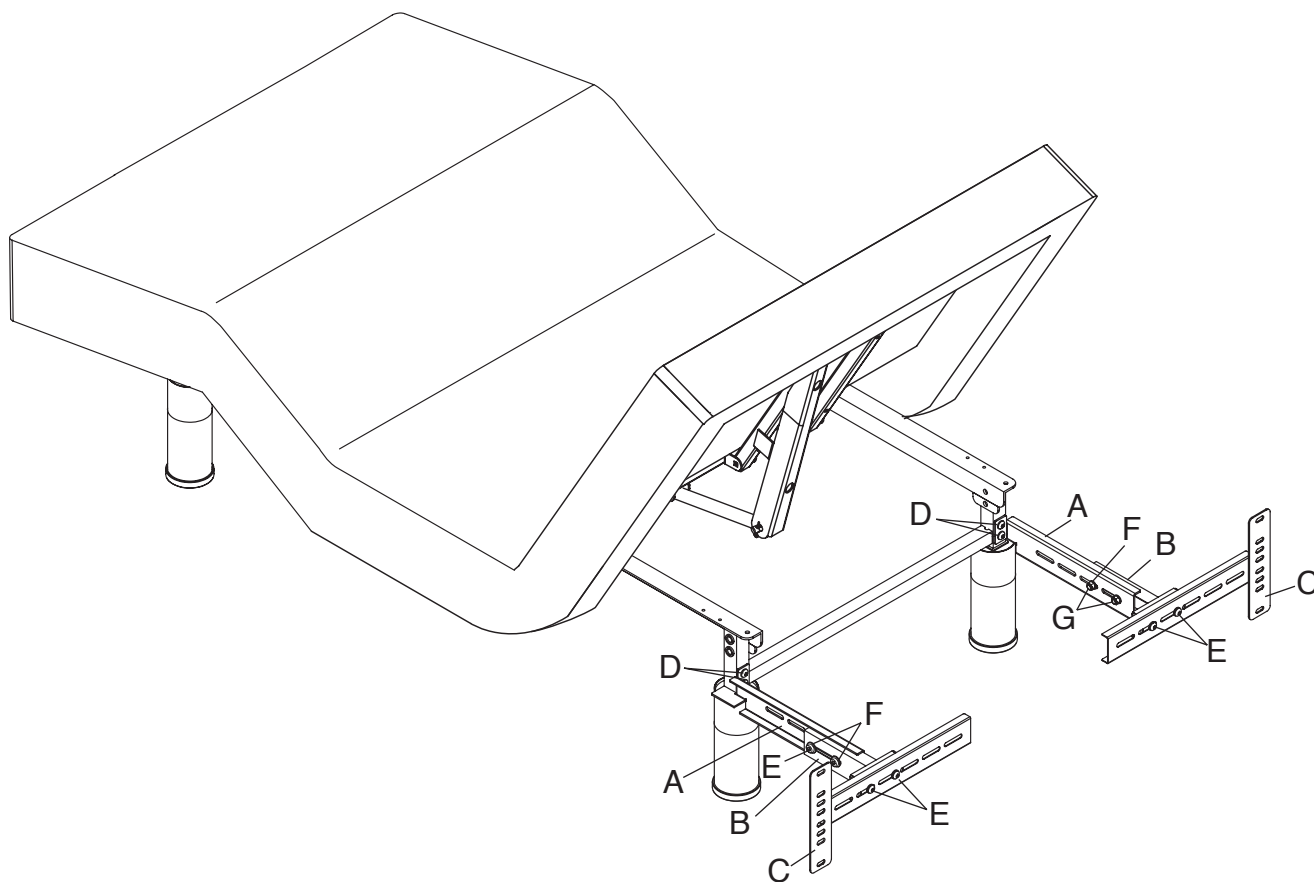
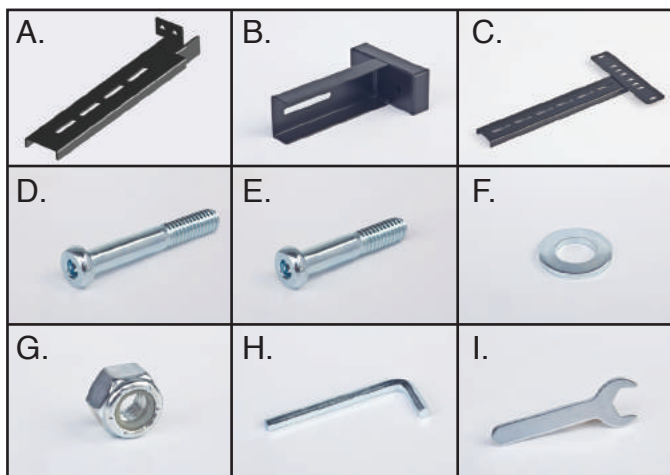

CUSTOMER SERVICE: 800-973-8374
SERVICE@POWERFLEXBASE.COM

Headboard Bracket Installation

STEP 1

Install the headboard brackets to the Adjustable Base. Place one bracket on the left-hand side of the base and one bracket on the right-hand side of the base.

1. Use the hand control to raise the head of the base in order to gain access to the Adjustable Base.
2. Bolt the Leg Clamp Bracket (A) to the leg using the headboard bracket bolts (D), and the 5/16" lock nut (G).
3. Bolt the inner Headboard Bracket (B) to the Leg Clamp Bracket (A) using the Headboard Bracket Bolts (E), the 5/16" washer (F), and the 5/16" lock nut (G).
4. Place the open side of the outer headboard bracket (C) onto the exposed square tube of the inner head board bracket (B). This will create a tight fit between (B) and (C). Place a Headboard Bracket Bolt (E) with a 5/16 Inch Washer (F) through the Outer Headboard Bracket (C) and into the Inner Headboard Bracket (B). Use a 5/16 Inch Washer (F) and 5/16 Inch Locking Nut (G) and hand tighten to allow for adjustment. Repeat same procedure for opposing side of the Adjustable Base.

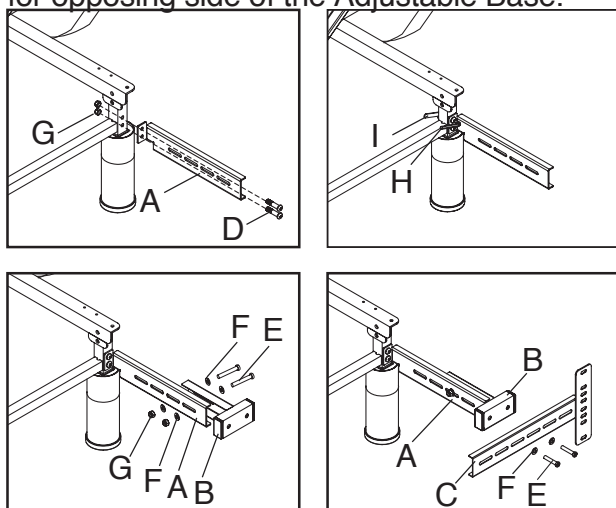

5. Ensure the headboard bracket is assembled a distance of 1.5 (38.1 mm) to 2 inches (50.8 mm) between the edge of the Adjustable Base and the headboard bracket assemblies.
6. Firmly tighten the headboard bolts (not included) to the end of the headboard bracket assembly.

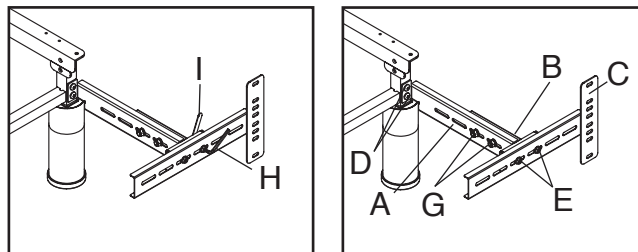

7. Measure the distance of the center to center mounting holes in the headboard.
8. Measure the distance of the center to center mounting holes in the headboard bracket assemblies.
9. If the headboard brackets require adjustments, loosen the bolts that are holding the outer headboard brackets and move them to the necessary distance. Reinstall the bolts and firmly tighten.

STEP 2

Place your mattress on top of your Adjustable Base.

Typical **Power-Flex™ 3 Adjustable Base** is **Headboard installation** now complete. If the base is equipped with a programmable setting or options, refer to the Hand Control Guide for more information.

The Bluetooth Module is OPTIONAL. Please read this section if your base has it.

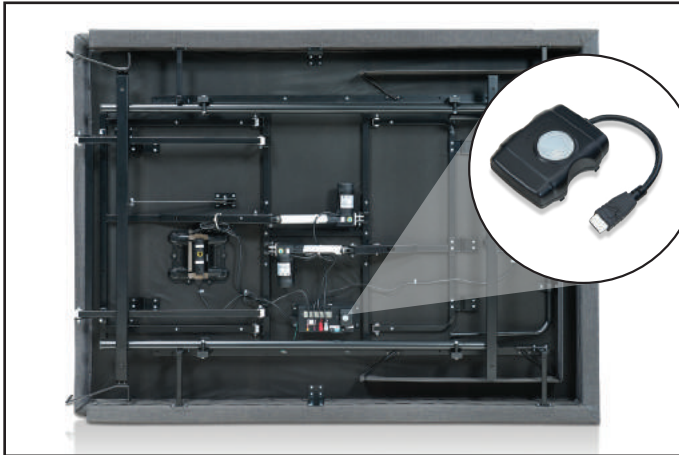

The Bluetooth Accessory Module allows you to control your Adjustable Base with your mobile device using a free, downloadable app. The Module is compatible with the following devices:
iPhone 4S or 5 series
iPad 3 or later
iPod Touch 5th generation
WiFi is not required for this device to operate.

Nightlight Feature

The LED light on the Bluetooth Accessory Module serves as a nightlight that can be controlled with the remote control on your mobile device.



How to Download the App Software

STEP 1

Please use any of the previously listed devices to log into the APP Store.

STEP 2

To control BOTH mattress and base type “**Personal Comfort**” or “**Instant Comfort**” in the search column.

STEP 3

Select the appropriate app.

STEP 4

Click install to download the app.

NOTE: Once the App is installed, when you open the app the Bluetooth Module will connect to your device automatically.

CUSTOMER SERVICE: 800-973-8374
SERVICE@POWERFLEXBASE.COM

Select Adjustable Bed Base

Only compatible with Power-Flex™ adjustable bed bases. These adjustable bed bases come with a Bluetooth adaptor that connects to the App.

King and California King bases come in two separate pieces and show up as two separate devices within the App. If you special ordered a Split Queen, it will also be in two separate pieces.

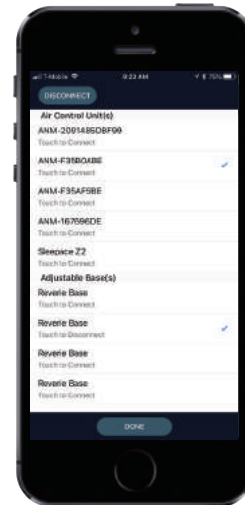

Test Adjustable Bed Base

Select "Test" to test your adjustable bed base. The head of the base should move up slightly. This will help you determine which side of the bed the device is located.

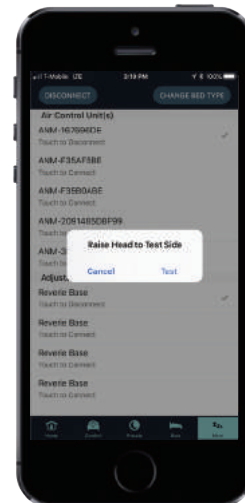

Choose Side

Stand at the foot of the bed when you start your test. This will help you determine which side of the bed your device is on.

Single bases (Twin, Twin XL, Full/Double, Queen) should select "Single" for App to work properly.

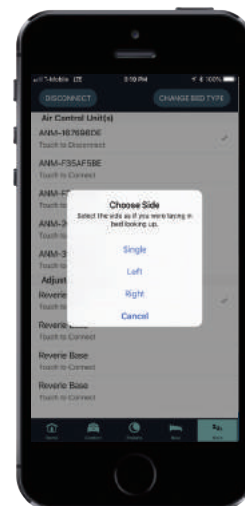

Sync Bases

Sync Head and Feet: For split adjustable bed bases (Split Queen, King and California King) you can choose to sync both sides together so the base functions as one unit.

Sync Feet Only: You can also sync only the feet sections of both bases so the feet will raise together and the head will be separate (great for Flex-Head mattresses).

Do Not Sync: You can tell the App to not sync any of the bases so the function independently from each other (recommended setting).

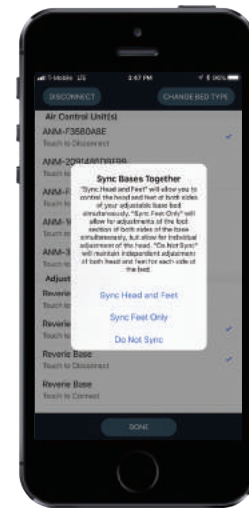

Adjustable Bed Base

Select "Base" tab at the bottom of the App and you will find several controls for your adjustable bed base. The pillow icon adjusts the head of the bed up and down. The foot icon adjusts the foot of the bed up and down. You can select which side to control by highlighting the "L" or "R" buttons. The "Dual" button allows you to quickly sync the base together to function as one unit. For your convenience we have included three presets positions for your adjustable bed base: flat, zero g and snore.

There are up to four memory settings per side of the base. This is if you want to save that perfect position to memory.

There is a light button for underbed illumination (if applicable). Some Bluetooth devices do not come with underbed lighting.

The massage icon allows you to turn on the head and/or the feet. You also can turn on "Full Body" massage. When you are finished select the "Stop" button.

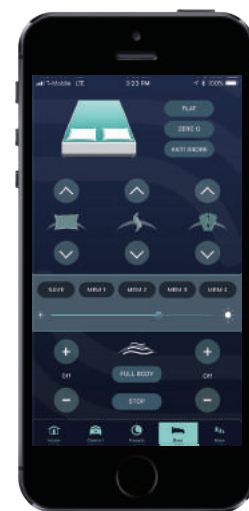

Saving an Adjustable Bed Base Setting

Once you have found a setting you would like to save, select "Save" from the memory settings area on the "Base" tab.

Select a Memory Button

Select a memory button to store your adjustable bed base setting. Select "Cancel" if you would like to go back.

CONNECTING ONE BED

[does not include KING or SPLIT KING bed sizes]

STEP 1

Hold Lightbulb button for 3 seconds to start searching.

STEP 2

The remote will only detect one bed and automatically connect.

CONNECTING ONE BED

[KING or SPLIT KING only]

STEP 1

Hold Lightbulb button for 3 seconds to start searching.

STEP 2A

[Select KING]

- Scroll using any of the up/down buttons H/L/F. Select by single-pressing lightbulb button.
- If it detects only 2 control boxes then will automatically connect with both control boxes on your bed.
- If it detects more than 2 control boxes, the LED display will show a list of all available control boxes within range [this usually means you have more than one bed in your house]
- Select desired control boxes you want to connect.

STEP 2B

[Select SPLIT KING]

- Scroll using any of the up/down buttons H/L/F. Select by single-pressing lightbulb button.
- When you choose SPLIT KING, will be asked if want to connect to both sides of bed?
- Select YES and will automatically connect with both sides.
- Select NO, then LED display will show a list of available beds within range.
- Select the desired beds you want to connect.

CONNECTING TWO BEDS

[OTHER - connecting two specific beds]

STEP 2C

[Select OTHER]

- After selecting OTHER you will be shown a list of all available beds and asked to select the beds you wish to connect [remote can show up to 20 beds]
- Select any two beds you wish to connect by single-pressing the lightbulb button.

NOTE: If it cannot detect any beds then will say NO BED FOUND.

NOTE:
Please remember to recycle all electronics.

ADDITIONAL TIPS FOR PAIRING TWO REMOTES

[for KING, SPLIT KING or two beds]

STEP 1

Our remote and Bluetooth technology allows for pairing/connecting two remotes with each side of the bed so each remote can control both sides of bed.

STEP 2

Pair/Connect one remote with both sides of the bed, then wait for that remote to enter sleep mode and pair/connect the other remote with both sides of bed.

STEP 3

If two remotes are connected to one bed, in order to actively use one of the remotes to control the bed you must make sure the other remote is in sleep mode. Waking up other remote will result in a disconnection from the control unit and the remote will show “No Bed Paired”.

NOTE:

This applies to the king bed situation, where two remotes are connected to both sides of the bed.

LED SIGNATURE LIGHT

A. RETURN ALL SECTIONS TO THE FLAT POSITION

B. RAISE(+) | LOWER(-) HEAD SECTION OF THE ADJUSTABLE BASE

C. RAISE(+) | LOWER(-) FOOT SECTION OF THE ADJUSTABLE BASE

D. ZERO GRAVITY

E. PROGRAM UP TO 2 MEMORY POSITIONS

F. ANTI SNORE

G. STOP ALL MESSAGE FEATURES

H. INCREASE(+) | REDUCE(-) MESSAGE INTENSITY ON HEAD SECTION OF THE ADJUSTABLE BASE

I. ALTERNATES BETWEEN MESSAGE WAVE SPEEDS 1, 2 AND 3

J. INCREASE(+) | REDUCE(-) MESSAGE INTENSITY ON FOOT SECTION OF THE ADJUSTABLE BASE

K. SELECT 1 OF 3 MESSAGE WAVE SPEEDS



OPERATING INSTRUCTIONS:

HEAD AND FOOT ADJUSTMENTS (B,C)

- Adjusts the head and foot sections to the desired positions.

Adjustable Base “FLAT” BUTTON (A)

- Levels the Adjustable Base to the flat position when the button is pressed and held for at least 1 second.

NOTE: The “FLAT” cycle can be interrupted and canceled by pressing the head or foot adjustment buttons (B,C).

PROGRAMMABLE MEMORY BUTTONS (E):

You can store 2 personalized memory positions.

- To Set a Memory Position: When in desired position, press and hold Memory button for more than 5 seconds until the LED light flashes 3 times to signal Memory position is stored.
- To recall a Memory Position: Press Memory button 1 -4 until LED lights up.

NOTE: Do not hold the memory button for more than 5 seconds otherwise a new memory position will be set.

ZERO GRAVITY (D)

- Allows your legs to be lifted to a position slightly above the chest, which enables blood flow to easily circulate back to the heart, thus reducing stress and fatigue.

ANTI SNORE (F)

- Raises the HEAD slightly for easier breathing.

HEAD AND FOOT MASSAGE CONTROLS (H,J)

- Turns on the corresponding massage unit (starting at intensity 5 of 10)
- Slowly increases or decreases massage intensity. To increase massage intensity, press (+) button. To decrease massage intensity, press (-) button.

NOTE: The lowest setting will turn off the corresponding massage unit.

WAVE MESSAGE MODE (K)

- Turns on both head and foot massage motors to one of the 3 save functions.

NOTE: You must stop the massage before you can switch to another wave function or to the full body massage.

MESSAGE STOP BUTTONS (G)

- Press for 2 seconds to stop all massage features.

NOTE: The massage feature is designed to automatically shut off after 30 minutes of continuous use.

FULL BODY MASSAGE FUNCTION (I)

- Turns on both head and foot massage motors and alternates between Wave modes 1, 2 and 3.

CUSTOMER SERVICE: 800-973-8374
SERVICE@POWERFLEXBASE.COM

ATTENTION: If the massage motors are operating and Head and Foot lift or Memory buttons are pressed, the massage motor will stop and resume operating after lift position reached. But if Flat button is pressed, the massage motors will not resume after flat position is reached.

ADDITIONAL REMOTE FEATURES:

- The **Power-Flex™ 3** Adjustable Base uses a RF (Radio Frequency) remote control system.

NOTE: This Adjustable Base may have minor intermittent performance due to RF Interference. This is a normal operation of the Adjustable Base and is not a defect.

- The buttons are back-lit, when a button is pressed, to aid the visibility of the remote in low light environments.
- Customers can control the remote without facing the receiver (best transmission range is within 9 feet or 3 meters)

SAFETY:

- If there is an overload weight condition on the head or foot mechanism, the control unit will automatically stop all functions.

NOTE: Once the excess weight is removed, the control unit will automatically start all functions after 30 seconds.

- If the massage motors are continuously used for a 30 minute period, the motors will automatically shut down.

- The input transformer voltage is AC 120V 60 HZ, the output voltage is DC 24V 3A. When there is a short circuit, a fuse on the transformer will be blown in order to protect the electrical equipment (Fuse: 1.5A).

ATTENTION: When the above situation occurs, the customer **MUST** seek professional assistance.

NOTICE:

The changes or modifications not expressly approved by the party responsible for compliance could void the user's authority to operate the equipment.

IMPORTANT NOTE:

- *To comply with the FCC RF exposure compliance requirements, no change to the antenna or the device is permitted. Any change to the antenna or the device could result in the device exceeding the RF exposure requirements and void user's authority to operate the device.*

THIS DEVICE COMPLIES WITH PART 15 OF THE FCC RULES. OPERATION IS SUBJECT TO THE FOLLOWING TWO CONDITIONS: (1) THIS DEVICE MAY NOT CAUSE HARMFUL INTERFERENCE (2) THIS DEVICE MUST ACCEPT ANY INTERFERENCE RECEIVED, INCLUDING INTERFERENCE THAT MAY CAUSE UNDESIRE OPERATION.

NOTE: The included remote is already paired with your Adjustable Base. No further action is required. Only replacement remote controls require use programming.

STEP 1

Place batteries into a remote control (3 x AAA batteries)



STEP 2

Ensure the Adjustable Base is plugged into a functioning outlet.

STEP 3

Press the learn button for 3 seconds.



Figure 1: Press "Learn Button" to initiate the RF learning mode.

NOTE: If a new signal is not received it will reset itself to normal mode in 10 seconds.

STEP 4

When the Green LED signature light illuminates, the RF frequency code setting function will be activated.

STEP 5

Press any button on the remote control.

STEP 6

When the receiver light flashes, you have completed the learning process of the RF frequency code.



Figure 2: A flashing Green LED indicates the control box has received the remote control signal.

PAIRING INSTRUCTIONS FOR JOINING 2 BASES

1 Wireless Remote Control and 2 Power-Flex™ 3 Adjustable Bases.

Use the same remote control to pair with the two Adjustable Base one after the other following the "Replacement Remote Control Programming" procedures (Step 3 - Step 6).

CUSTOMER SERVICE: 800-973-8374
SERVICE@POWERFLEXBASE.COM

Each base is already paired with the remote control that comes with it. Each control box has space in its memory to remember two remote controls. **King/Cal King units require you to pair at least 1 remote to both bases so that both bases will move in sync when using that remote. You can also pair two remotes to two bases, so that either remote can control both bases at the same time.**

When reading these instructions assume that you have two power bases (either two TXL or two Split Cal King bases), and two remote controls – one that came with each base. We will call these Base 1 and Base 2, and Remote 1 (for Base 1) and Remote 2 (for Base 2).

If you want to marry Remote 2 to base 1:

Take “Remote 2” and press the learn button on the PLC for “base 1” When the green LED lights up, press any button on “Remote 2” As soon as the LED begins to Blink, **release the button on “Remote 2” (see Steps 3-6 on Page 17). Do NOT hold the remote button after the light blinks, and do NOT press it again (see Note below). If you do you will remove Remote 1 from base 1’s memory.** Wait until the green LED turns solid and then turns off. Now both remotes will operate base 1.

If you want to marry Remote 1 to base 2:

Take “Remote 1” and press the learn button on the PLC for “base 2” When the green LED lights up, press any button on “Remote 1”. As soon as the LED begins to Blink, **release the button on “Remote 1” (see Steps 3-6 on Page 17). Do NOT hold the remote button after the light blinks, and do NOT press it again (see Note below). If you do you will remove Remote 2 from base 2’s memory.** Wait until the green LED turns solid and then turns off. Now both remotes will operate both bases in tandem.

Note: While the light is blinking if you release the button on the remote and press it a second time, or if you continue to hold the button the PLC can jump to the second slot and kick out the first remote. This is why some people have a difficult time joining the remotes. If they are patient and follow the process described they will not have a problem.

POWER-FLEX™ 3

Remote Control Emergency Power Down Feature

Your **Power-Flex™ 3** Adjustable Base has an emergency lowering feature in the event that your Adjustable Base is in the raised position and has lost power due to a power outage.

STEP 1

Locate and remove the cover for the 9 volt batteries.



Figure 1

STEP 2

Install the two (2) alkaline 9 volt batteries.



Figure 2

STEP 3

Replace battery cover.



Figure 3

STEP 4

Press the “FLAT” button (A) or the individual lowering buttons (B,C).



Figure 4: Lower the Adjustable Base using the 9 volt battery back up system

Your Adjustable Base should lower to the flat position.

NOTE: The two (2) 9 volt batteries are only intended to be used once. After you complete the emergency lowering, the batteries need to be replaced with new alkaline batteries.

CUSTOMER SERVICE: 800-973-8374
SERVICE@POWERFLEXBASE.COM

In the Event the **Power-Flex™ 3** Adjustable Base fails to operate, investigate the symptoms and possible solutions provided in the chart below:

Symptom	Solution
Remote control LED illuminates and appears to be operable but will not activate the Adjustable Base.	<ul style="list-style-type: none"> Verify the power cord is plugged into a working, grounded electrical outlet. A <i>grounded, electrical surge protection device is recommended</i>. Test the outlet by plugging in another working appliance.
No features of the Power-Flex™ 3 Adjustable Base will activate.	<ul style="list-style-type: none"> Program the remote control (see the Remote Control Guide, included with this product, for programming procedures). If equipped with a power down box, make certain the power down box is easily accessible. Relocate the power down box if required. Unplug the power cord, wait 45 seconds and plug it in to reset the electronic components. The electrical circuit breaker may be tripped. Check the electrical service breaker box to verify. The surge protection device or electrical outlet is defective. Test the outlet by plugging in another working appliance.
Remote control LED will not illuminate.	<ul style="list-style-type: none"> Replace the batteries in the hand control. Ensure the batteries are installed correctly.
Head or foot section will elevate but will not return to the horizontal (flat) position.	<ul style="list-style-type: none"> The Adjustable Base mechanism may be obstructed. Elevate the Adjustable Base and check for an obstruction. Remove the obstruction. The head section may be too close to the wall. The headboard may be too close to the edge of the mattress. Verify a 1.5" (38.1mm) to 2" (50.8mm) distance is between the headboard brackets and the mattress. Adjust if required.
Head or foot lift function has minor interference during operation.	<ul style="list-style-type: none"> Check batteries in remote, replace if necessary. Make sure that you are following the duty cycle of the motors (do not operate more than three (3) minutes over a thirty (30) minute period, approximately 10% duty cycle). Press the lift buttons squarely & accurately. Remote may be experiencing common Radio Frequency Interference from other radio transmitting devices.

Symptom	Solution
Excessive massage motor noise.	<ul style="list-style-type: none">• If the Adjustable Base is located on hard surface flooring, place carpet pieces.• Elevate the head or foot section a short distance (with the hand control) to realign the lift/lower mechanisms with the Adjustable Base support platform.• Verify that the Adjustable Base is not positioned against a wall, nightstand, or other object that may cause the vibration or noise.• If the Power-Flex™ 3 is installed over a Adjustable Base, verify the massage motors are not causing the Adjustable Base (or Adjustable Base components) to vibrate.• Verify that the headboard attachment hardware is firmly tightened (if used).

CUSTOMER SERVICE: 800-973-8374
SERVICE@POWERFLEXBASE.COM

20 Year Limited Warranty for Reverie Adjustable Bases

Ascion, L.L.C. d/b/a Reverie (hereinafter referred to as “Reverie”) warrants to the end user (hereinafter referred to as “Purchaser”) that during the twenty (20) year term of this Limited Warranty, Reverie will, at its sole discretion and option, repair or replace Purchaser’s motorized bed frame or motorized bed foundation parts (hereinafter referred to as “adjustable bed” or “adjustable beds”) that are found to be defective due to faulty workmanship or materials, subject to the limitations set forth herein.

This Limited Warranty begins on the “warranty commencement date” which is the date of purchase for new unused adjustable beds and the date of manufacture for adjustable beds that have been used as floor or display models. Thus, on a floor model adjustable bed, the warranty is a portion of the 20-year Limited Warranty. If original proof of purchase is not provided by Purchaser, Reverie reserves the right to determine that the adjustable bed is not covered by this Limited Warranty or to use the manufacturing date as the warranty commencement date. This Limited Warranty extends only to the original Purchaser and may not be transferred.

YEAR 1: FULL COVERAGE OF PARTS AND LABOR

Upon receiving reasonable notice during the first year from the warranty commencement date, Reverie will send replacement parts (at no cost to the Purchaser) for any defective adjustable bed part to the Purchaser, and Reverie will pay all pre-authorized labor and transportation costs associated with the repair or replacement of any parts Reverie determines to be defective. This one (1) year Limited Warranty shall not apply if Purchaser does not return any and all defective parts to Reverie within 15 days of Purchaser’s receipt of replacement part(s).

YEARS 2-5: FULL COVERAGE OF PARTS ONLY

Upon receiving reasonable written notice at any point in time that is more than one (1) year and up to five (5) years from the warranty commencement date, Reverie will offer replacement parts for any defective adjustable bed part to the Purchaser. This four (4) year Limited Warranty shall not apply if Purchaser does not return any and all defective parts to Reverie within 15 days of Purchaser’s receipt of replacement part. Purchaser shall bear all service, transportation, labor and shipping costs related to the delivery and/or replacement of the defective part.

YEARS 6-20: FULL COVERAGE OF FRAME ONLY

Upon receiving reasonable written notice at any point in time that is more than five (5) years and up to twenty (20) years from the warranty commencement date, Reverie will offer replacement parts for any mechanical part of the frame found to be defective. Electronics, electrical components, drive motors and massage motors are excluded from this Limited Warranty. Purchaser shall bear all service, transportation, labor and shipping costs related to the delivery and/or replacement of the defective part.

ADDITIONAL TERMS AND CONDITIONS

This Limited Warranty does not apply: (a) to any damage caused by the Purchaser; (b) if there has been any unauthorized repair or replacement of adjustable bed parts; (c) if the adjustable bed has been mishandled (whether in transit or by other means), subjected to physical or electrical abuse or misuse, or otherwise operated in any way inconsistent with the operation and maintenance procedures outlined in the Owner's Manual, this Limited Warranty, and any other applicable document published or approved by Reverie; (d) to damage to mattresses, fabric, cables, electrical cords or items supplied by any Reseller of the adjustable bed, (contact the Reseller or other relevant party for warranty information on these items.); (e) if there have been any unnecessary service calls, including costs for in-home service calls solely for the purpose of educating the consumer about the adjustable bed or for finding an unsatisfactory power connection.

Repairs to or replacement of the adjustable bed or its components under the terms of this Limited Warranty will apply to the original warranty period and will not serve to extend such period.

The decision to repair or to replace defective parts under this Limited Warranty shall be made exclusively by Reverie in its sole and exclusive discretion.

REPAIR OR REPLACEMENT SHALL BE THE SOLE REMEDY OF THE PURCHASER. THERE SHALL BE NO LIABILITY ON THE PART OF REVERIE AND THEIR RESPECTIVE PARENTS, SUBSIDIARIES, DIVISIONS OR AFFILIATES FOR ANY SPECIAL, INDIRECT, INCIDENTAL, OR CONSEQUENTIAL DAMAGES OR FOR ANY OTHER DAMAGE, CLAIM, OR LOSS NOT EXPRESSLY COVERED BY THE TERMS OF THIS LIMITED WARRANTY.

This Limited Warranty does not include reimbursement for inconvenience, removal, installation, setup time, loss of use, shipping, or any other costs or expenses.

CUSTOMER SERVICE: 800-973-8374
SERVICE@POWERFLEXBASE.COM

UNLESS OTHERWISE EXPRESSLY STATED IN THIS DOCUMENT, REVERIE AND THEIR RESPECTIVE PARENTS, SUBSIDIARIES, DIVISIONS AND AFFILIATES EXPRESSLY DISCLAIM ANY OTHER WARRANTY WHATSOEVER, EXPRESS OR IMPLIED, INCLUDING BUT NOT LIMITED TO IMPLIED WARRANTIES OF MERCHANTABILITY, FITNESS FOR A PARTICULAR PURPOSE, AND FREEDOM FROM DEFECTS AND WORKMANSHIP.

Some states may not allow the exclusion or limitation of incidental or consequential damages in some circumstances, so the above limitation or exclusion may not apply to every Purchaser. This Limited Warranty gives the Purchaser specific legal rights, and the Purchaser may also have other rights, which may vary from state to state. This Limited Warranty is valid in all states of the United States except Alaska, Hawaii and Puerto Rico

If you experience any trouble with your adjustable bed during the warranty period, please consult the troubleshooting guide provided with your adjustable bed and online (if applicable), or the troubleshooting video provided online (if applicable). If problems persist after following these instructions, please call:

1-800-973-8374

SERVICE@POWERFLEXBASE.COM

Please have your receipt ready and available.

Thank you and enjoy your Adjustable Base.

Register Online. For easy registration of your warranty visit www.reverie.com

Please prepare a digital copy of your proof of purchase
(invoice or sales receipt) when registering online.
You may be required to provide the Serial Number for registration,
you can find it on the Law Tags attached to the base.

Manufactured by Reverie®

For Warranty and Service:

800-973-8374

SERVICE@POWERFLEXBASE.COM

341 Central Ave. Silver Creek, NY 14136

www.reverie.com



Name _____

Phone _____

Address _____

City _____ State/Province _____ Zip/Postal Code _____

Purchase Date _____

Bed Serial Number _____

Email Address _____

To register your warranty via mail, send this portion and a copy of your proof of purchase (invoice or sales receipt) to:

Reverie Warranty Dept. 314 Central Ave. Silver Creek, NY 14136 (800-973-8374)

CUSTOMER SERVICE: 800-973-8374
SERVICE@POWERFLEXBASE.COM

This section contains a large area for taking notes, consisting of approximately 30 horizontal lines. At the bottom of this area is a dark blue rounded rectangular bar.

POWER-FLEX™ 3

Power-Flex™ Adjustable Base built by:



CUSTOMER SERVICE: 800-973-8374
SERVICE@POWERFLEXBASE.COM