

IMAGE

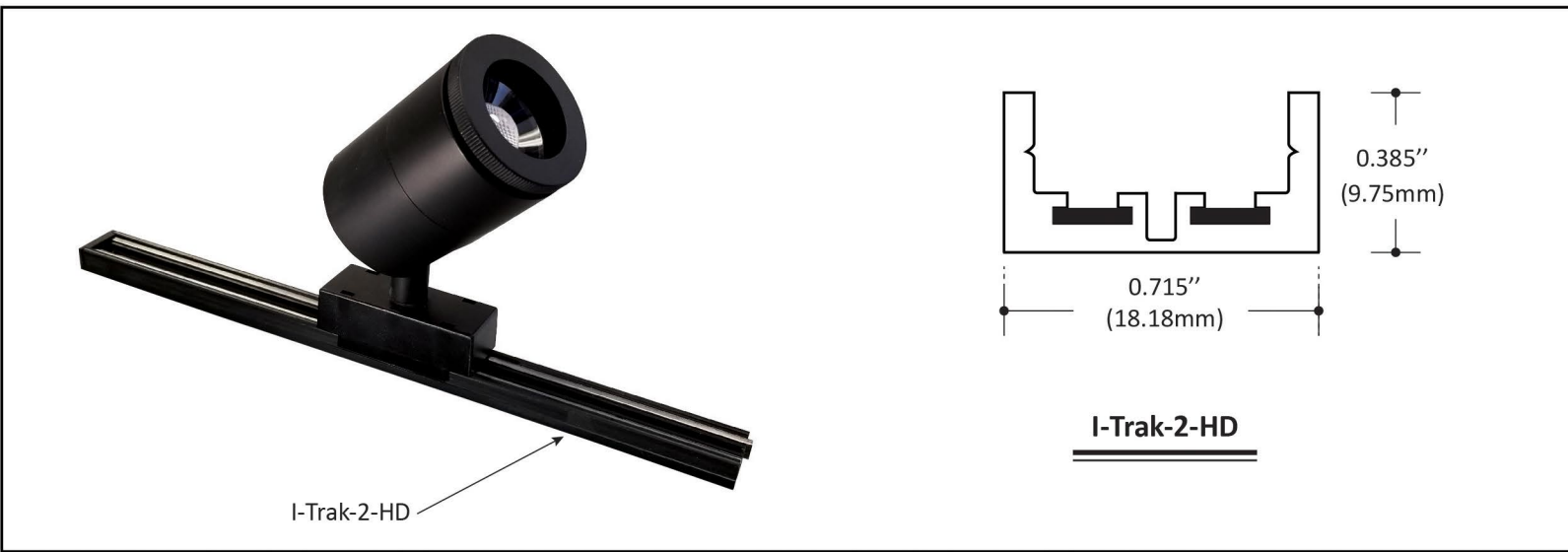

Fixture	Finish	Color	Optics	LED	Input	Power	CCT	CRI	General
Lazer 9	Anodized Aluminum / Painted	Silver / Black / White	zoom 20°- 60° Adjustable 90° +350°	High Power LED 1 Pc	24VDC Constant Voltage	6W	3000 / 4000K	90+	Wireless & Magnetic detachable design; Nonpolarity

DESCRIPTION

- Designed for retail display applications that are not static and in a state of flux due to changes in product mix or seasonality.
- Allows hidden power connections to shelving that vary in height with changes in product mix.
- The heart of the Intelli-Trak-2-HD system is a low profile extrusion that distributes power through a system of magnetic power distributors that can be moved and placed anywhere along its length.
- Magnetic power distributors have polarized connectors that allow simple plug and play connections to a myriad of Revlite lighting fixtures.
- Intelli-Trak-2-HD is field cuttable and is able to be surface mounted with double faced adhesive tape or #4 screws. IT was also designed to be elegantly recess mounted into millwork where it becomes flush with the walls into which it is installed.
- Able to be surface mounted with magnets, double faced tape or #4 screws.
- Fixtures have polarity correction allowing them to work in any direction.

SPECIFICATIONS

Input Voltage	24V DC
Wattage	6W
Color Temperature	3000K, 4000K
Lumen Output	490 lm
CRI	90+
Beam Angle	20° - 60°
Efficacy	80 lm/W
Finish	Black, Silver, White
Environment	UL Listed for Dry Location (Indoor only)
Certification	

* Product specifications subject to change without notice.
* Note: To reduce risk of fire, do not install in a compartment smaller than 450 cubic/inches per 14.5W max.

APPLICATIONS

- Restaurant and Bar Shelving, Wine and Liquor Displays
- Case Lighting for Glassware and Bookcases
- Museum, Gallery and Art Exhibits
- Store Fixture Shelving and POS Stations
- Product Displays for Retail, Commercial and Work Environments
- Under Countertop Displays in Retail and Hospitality Environments

ORDERING INSTRUCTIONS

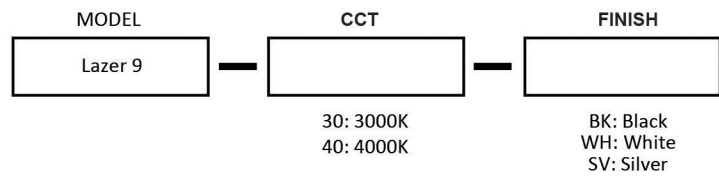

- Note:
- Should be used with I-Trak-2-HD magnetic track.
 - Sold separately.
 - Review I-Trak-2-HD spec sheet for more details

Type	
Project	
Catalog No.	

DIMENSION DRAWING

