

Type	
Project	
Catalog No.	

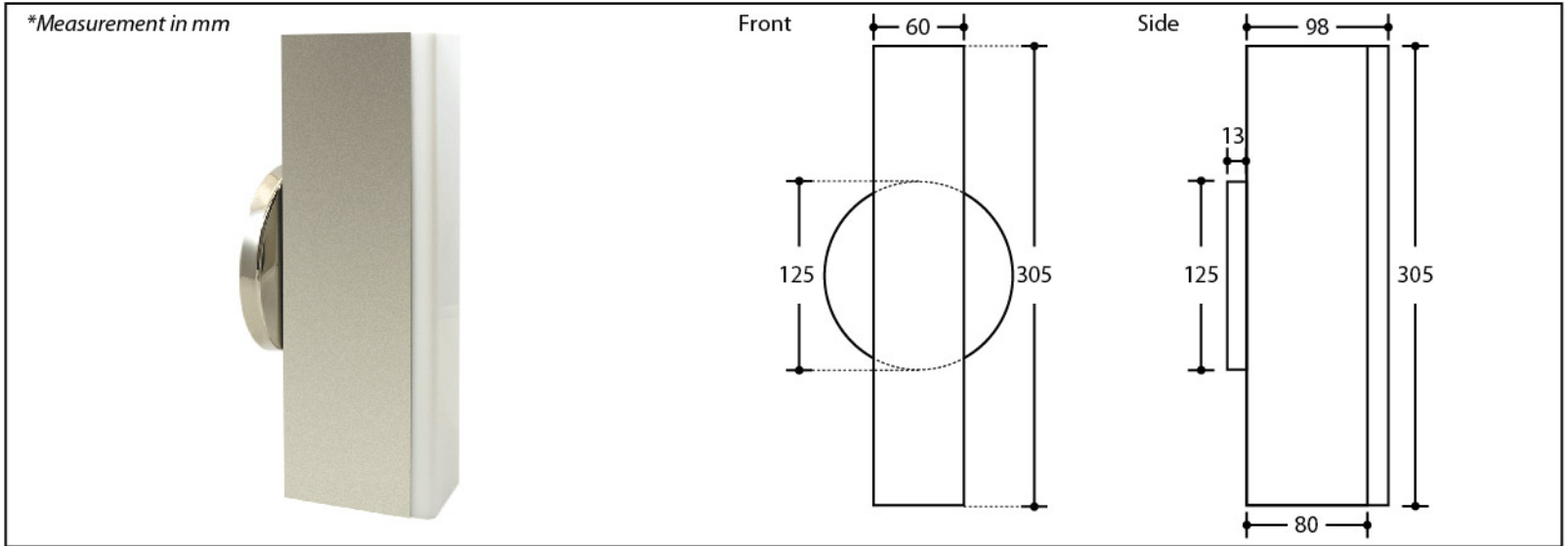

DESCRIPTION

Designed for new construction and retrofit applications. This 305mm fixed diffuser wall sconce houses direct drive AC LEDs configuration.

FEATURES

Mechanical

- Housing constructed of 2.0mm thick steel, chrome plated for a robust long life luminaire
- Mounting plate provides direct connection to standard junction boxes
- UL / CSA certified

Electrical

- 120 VAC input
- AC LEDs
- Power consumption: 12W

Optics

- Optical diffuser of polycarbonate of 3mm thickness with reduced glare
- Diffuser is 305 X 60 X 98 mm and easily removable without tools

Lens

- Standard opal white or frosted white. Custom available.

Listings

- Fixture is cULus listed

SPECIFICATIONS

Input Voltage	120 VAC (universal)
Wattage	12W
Colour Temp	2700K / 3000K / 4000K
Dimming	Triac
Lumen Output	1080 lumens
CRI	≥ 85
Power Factor	> 0.9
Lamp Life	> 50,000 hours
Environment	IP20
Certification	cULus
Warranty	3 years - see published warranty terms for details

* Product specifications subject to change without notice.

Warranty

- One (1) year warranty against defects in materials and workmanship
Warranty period is for 3 years when installed according to Revlite installation instructions and the applicable building codes

ORDERING INSTRUCTIONS

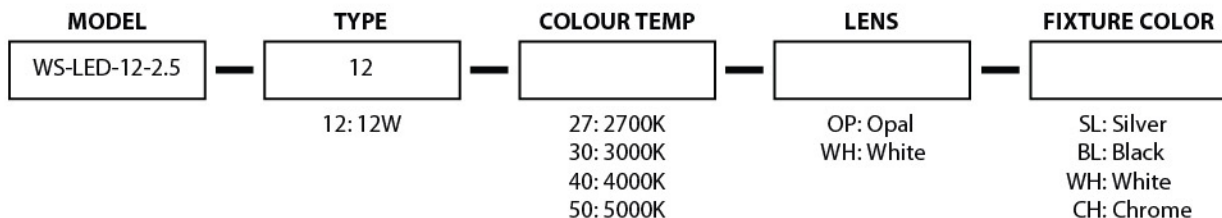

Example: WS-LED-12-2.5-12-30-WH = WS-LED-12-2.5, 12W, 3000K, white lens