

Type	
Project	
Catalog No.	

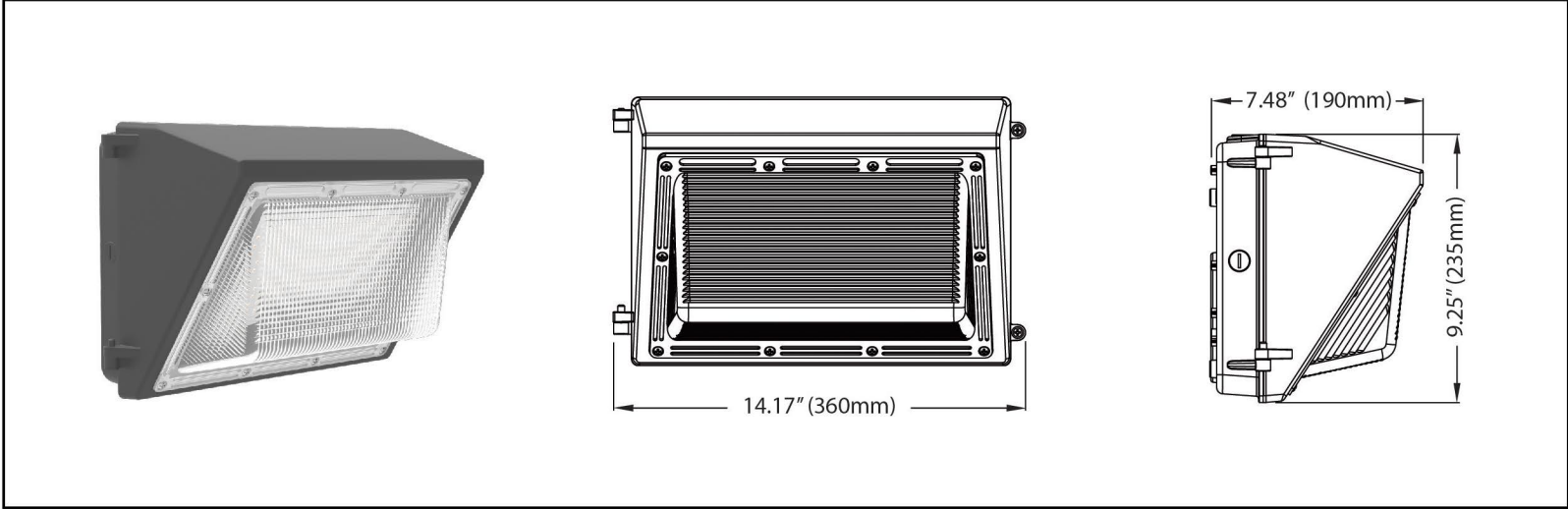

DESCRIPTION

The sophisticated heat sinking technology of this wall pack makes it perfect for industrial areas, commercial areas or other outdoor areas requiring luminaires. The advanced heat sink technology allows amazing performance in a small package making LEEDs certification possible even in high density industrial applications.

FEATURES

- Power: 30W / 45W / 70W / 100W
- Sophisticated heat sink technology
- Beam angle: 110°
- Light source: LED (3000K / 4000K / 5000K)
- Luminous flux: 2,750 - 10,500 lumens
- Protection class: IP65
- Certification: cULus, CE, RoHS, DLC
- Size: H235 X D190 X L360 mm

SPECIFICATIONS

Input Voltage	AC100 - 277V
Wattage	30W / 45W / 70W / 100W
Colour Temp	3000K / 4000K / 5000K
Light Sensor	Optional
Lumen Output	2,750 - 10,500 lumens
CRI	>80
Beam Angle	110°
Power Factor	≥0.9
Lamp Life	≥50,000 hours
Environment	IP65
Certification	cULus, CE, RoHS, DLC
Warranty	5 years - see published warranty terms for details

* Product specifications subject to change without notice.

ORDERING INSTRUCTIONS

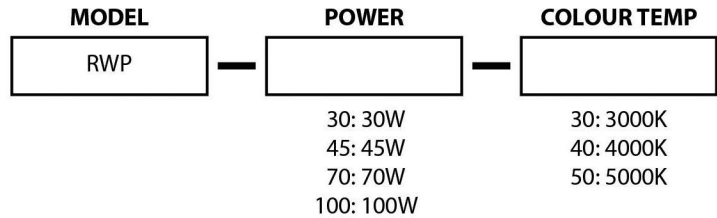

Example: RWP-45-30 = RWP, 45W, 3000K