



● Manuel de pièces

Parts manual ●

Pulvérisateur agricole

Agricultural sprayer

PORTÉE TRADITION

Modèles ● Models

P950E ● P1135E ● P1915E

MS Gregson Inc.

4300 Vachon
Drummondville
Qc, Canada, J2B 6V4

Tel. 819-474-1910
Fax 819-474-5317
info@msgregson.com
www.msgregson.com

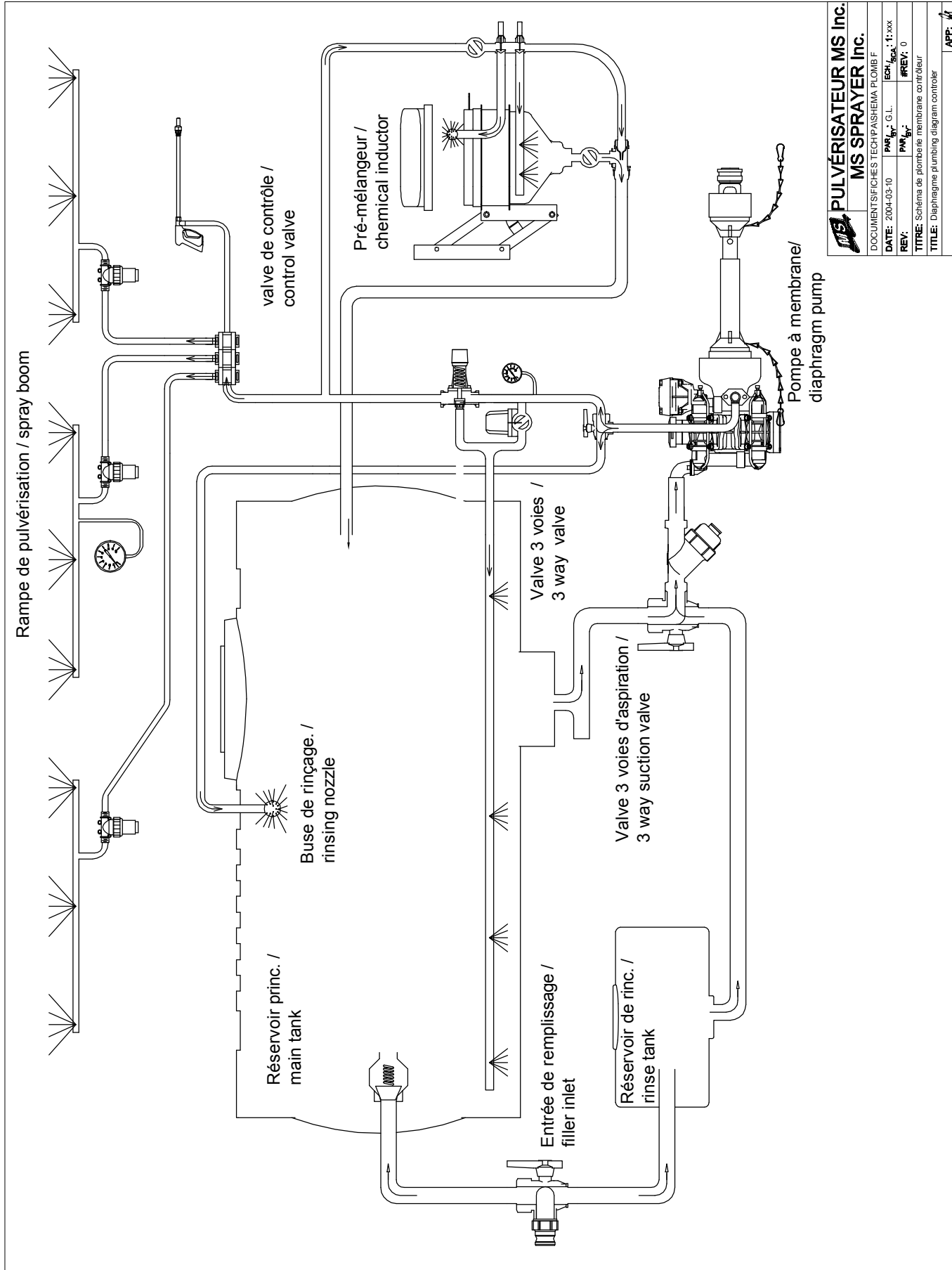

MS PULVÉRISATEUR MS Inc.	
MS SPRAYER Inc.	
DOCUMENTS/FICHES TECH/PASHEMA PLOMB F	
DATE: 2004-03-10	PAR: G.L.
REV: 0	ÉCH: 1:xxx
PAR: 0	REV: 0
TITRE: Schéma de plomberie membrane contrôleur	
TITLE: Diaphragm plumbing diagram controler	
APP: <i>[Signature]</i>	

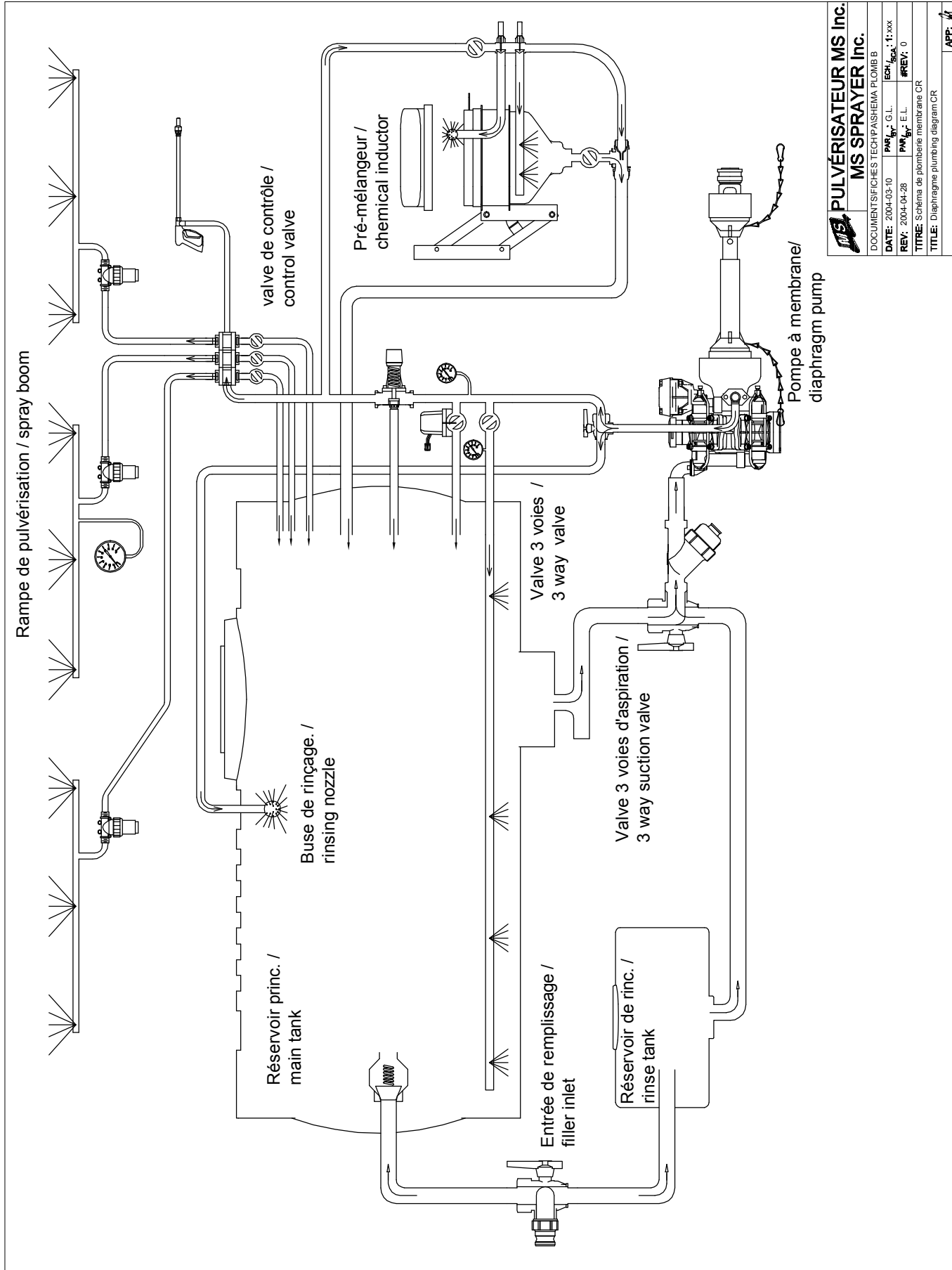

IMPRIME LE: 2004-05-20 15:59:02 PAR: LANOIEG

PULVÉRISATEUR MS Inc.			
MS SPRAYER Inc.			
DOCUMENTS/FICHES TECH/PASHEMA PLOMB B			
DATE: 2004-03-10	PAR: G.L.	ÉCH: 1:xxx	
REV: 2004-04-28	PAR: E.L.	REV: 0	
TITRE: Schéma de plomberie membrane CR			
TITLE: Diaphragm plumbing diagram CR			
			APP: <i>[Signature]</i>

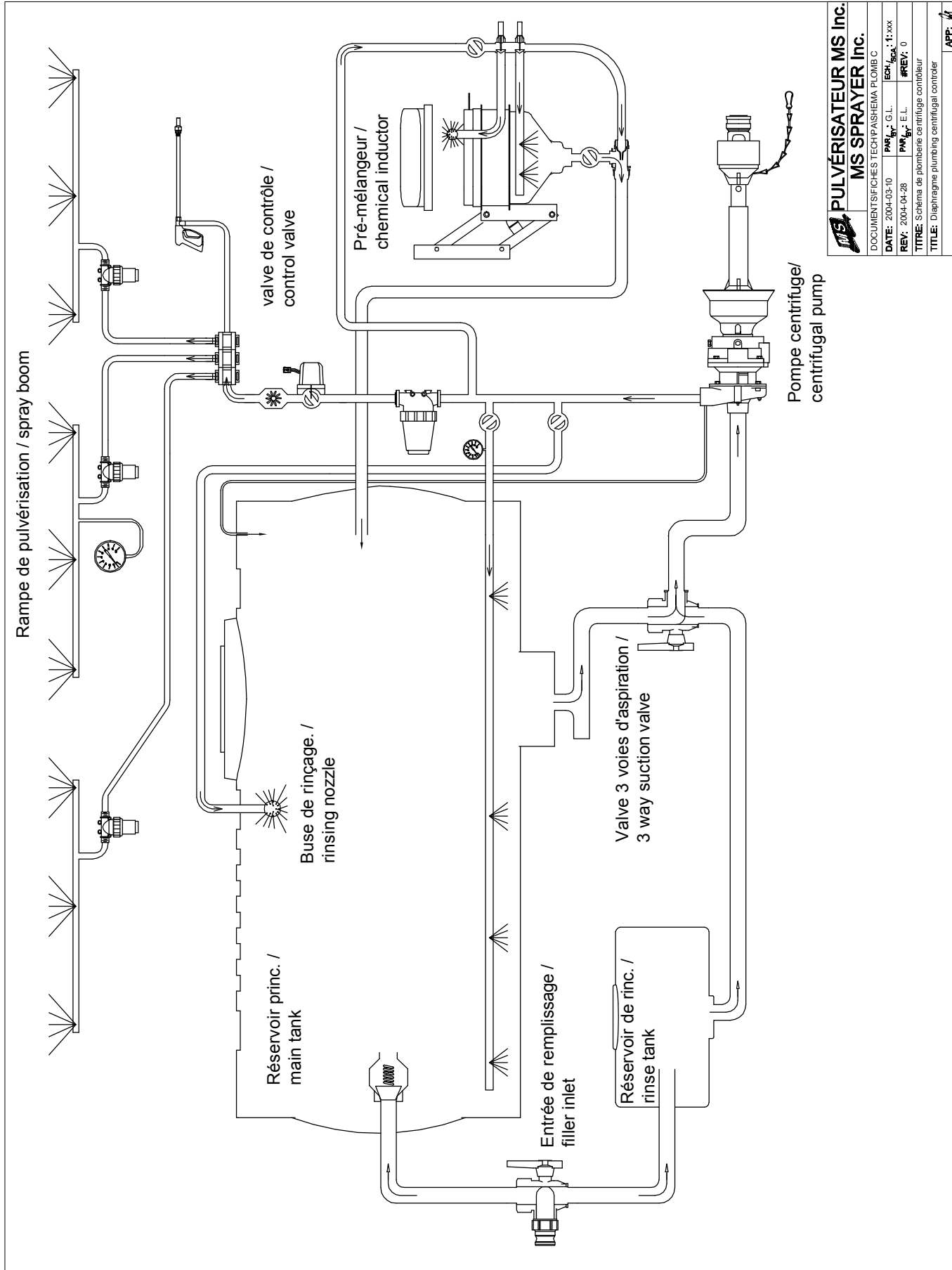

MS PULVÉRISATEUR MS Inc.
MS SPRAYER Inc.

DOCUMENTS/FICHES TECH/PASHEMA PLOMB C

DATE: 2004-03-10 PAR: G.L. ECH: 1:xxx
 REV: 2004-04-28 PAR: E.L. PREP: 0

TITRE: Schéma de plomberie centrifuge contrôleur
 TITLE: Diaphragm plumbing centrifugal controller

APP: *[Signature]*

IMPRIME LE: 2004-05-20 15:58:48 PAR: LANOIEG

#	REF.	Q.	L"
28	AU-1889825	4	17"
29	SN-TS198	2	(76")

#	Ref.	Q.
1	AC-SP0003RT	1
2	RA-5444R	1
3	JB-SE34NY	1
4	BT-12214	2
5	BT-FW12	2
6	BT-LN12	6
7	MS-SR3PA	2
8	AU-HP0814	2
9	MS-ECH4920R2	1
10	MO-DA301020	1
11	MS-P1135R3-G	1
12	MS-BE1121	2
13	MO-DA307012	3
14	AU-18MTD007	2
15	BT-126FL	4
16	MS-AC01	4
17	AU-DECP1135E	2
18	AC-OT030031	1
19	JB-33710019	1
20	JB-RB10034NY	1
21	RA-5034P	1
22	MP-5041061	1
23	CA-6810B	1
24	BT-FW516	4
25	BT-LW516	4
26	BT-51634	4
27	AU-DECMSLOGOAG	2

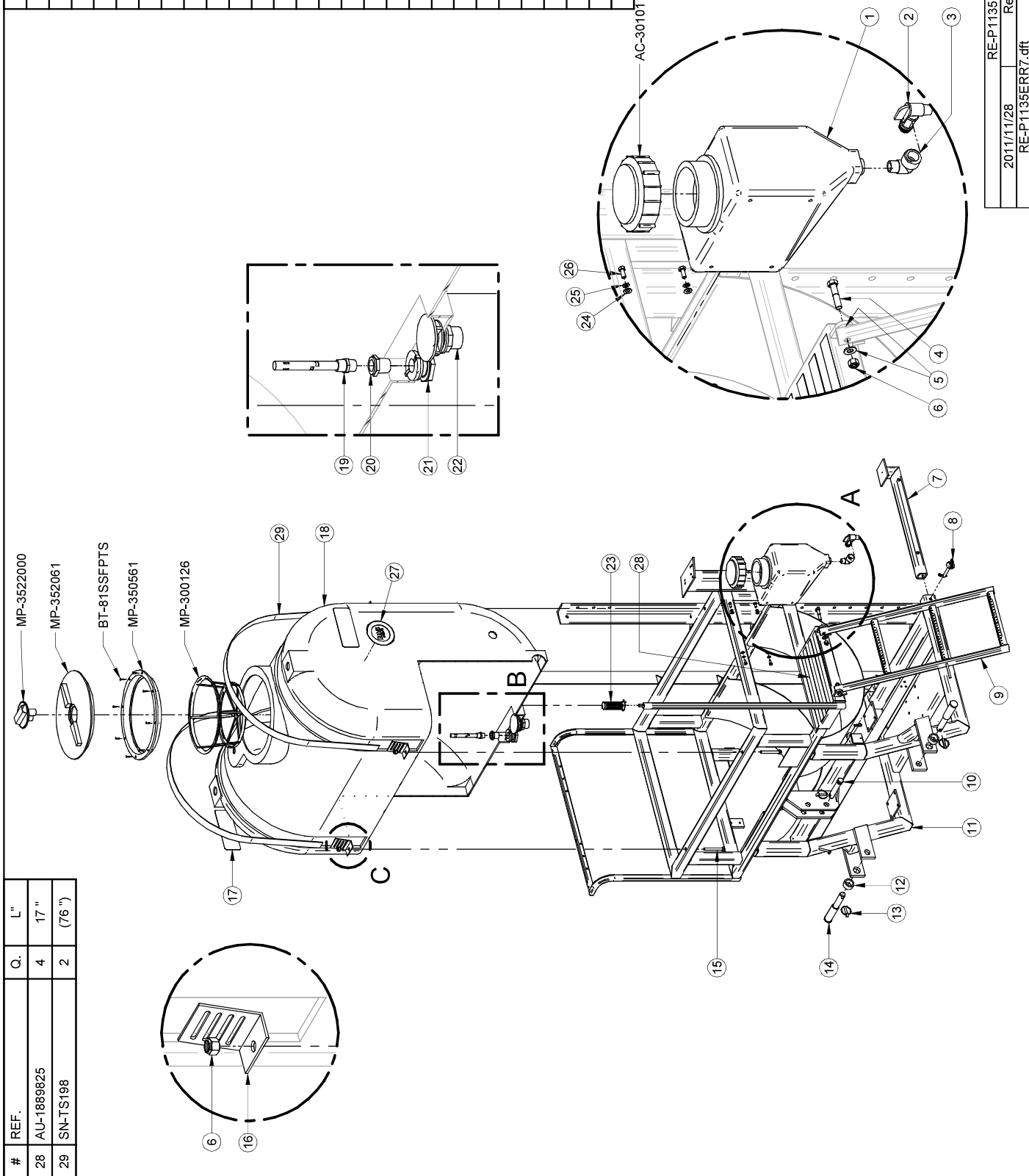

2011/11/28	RE-P1135ERR7.asm	Pg:1-3
Rev. 1	RE-P1135ERR7.dft	Explose 1

#	Ref.	Q.	"
26	SN-TS198	2	(76")
27	AU-1889825	4	17"

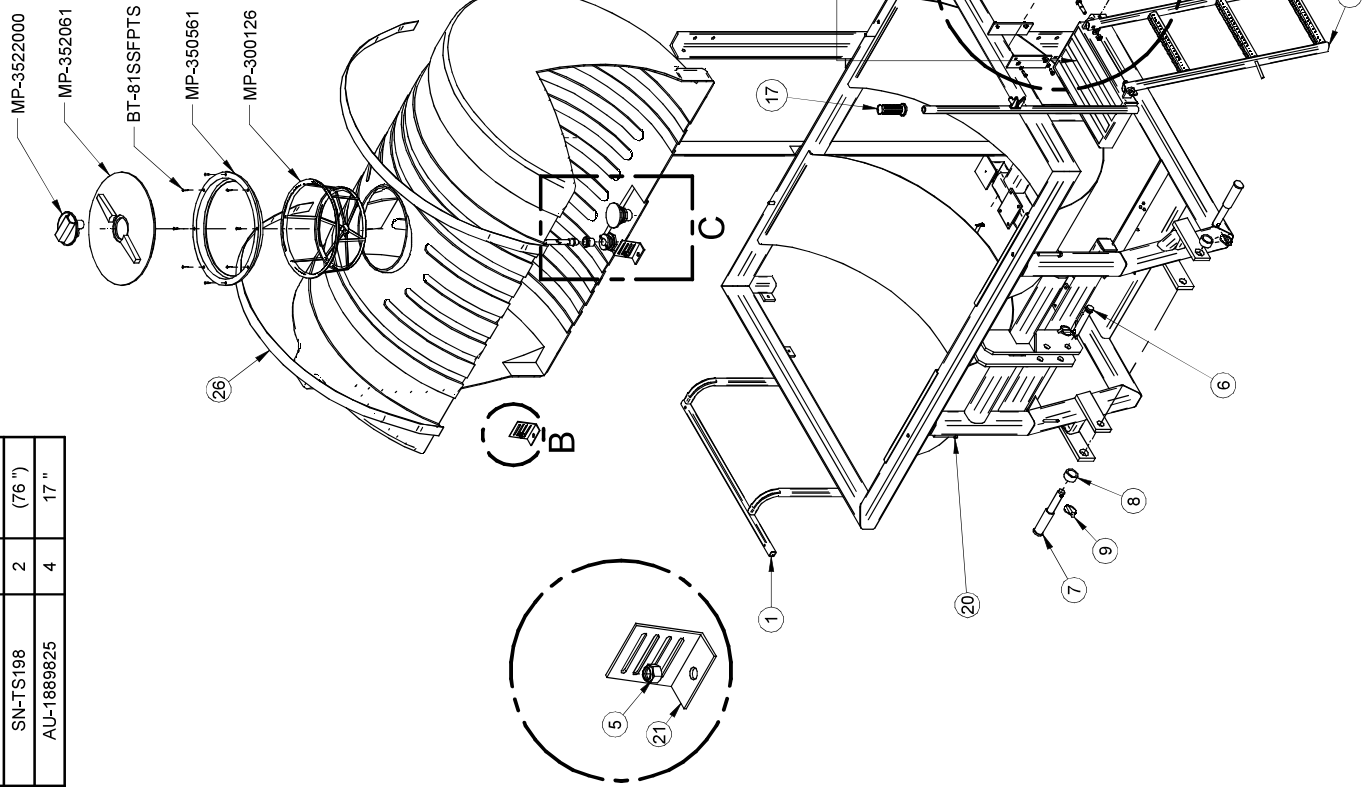

#	Ref.	Q.
1	MS-P1915R1-G	1
2	RA-10794	1
3	AC-SP0003RT	1
4	MS-ECH4920R2	1
5	BT-LN12	6
6	MO-DA301020	1
7	AU-18MTD007	2
8	MS-BE1121	2
9	MO-DA307012	3
10	MP-5041061	1
11	RA-5034P	1
12	JB-RB10034NY	1
13	JB-33710019	1
14	BT-FW516	4
15	BT-LW516	4
16	BT-51634	4
17	CA-6810B	1
18	RA-5444R	1
19	JB-SE34NY	1
20	BT-126FL	4
21	MS-AC01	4
22	MS-SR3PA1915	2
23	AU-HP0814	2
24	BT-12214	2
25	BT-FW12	2

#	Ref.	Q.	"
6	LV-12N	1	(175")

#	Ref.	Q.
1	AU-L141200M	2
2	DA-SHAS16	1
3	MP-G40004	1
4	MP-118426	1
5	DA-HS16	2

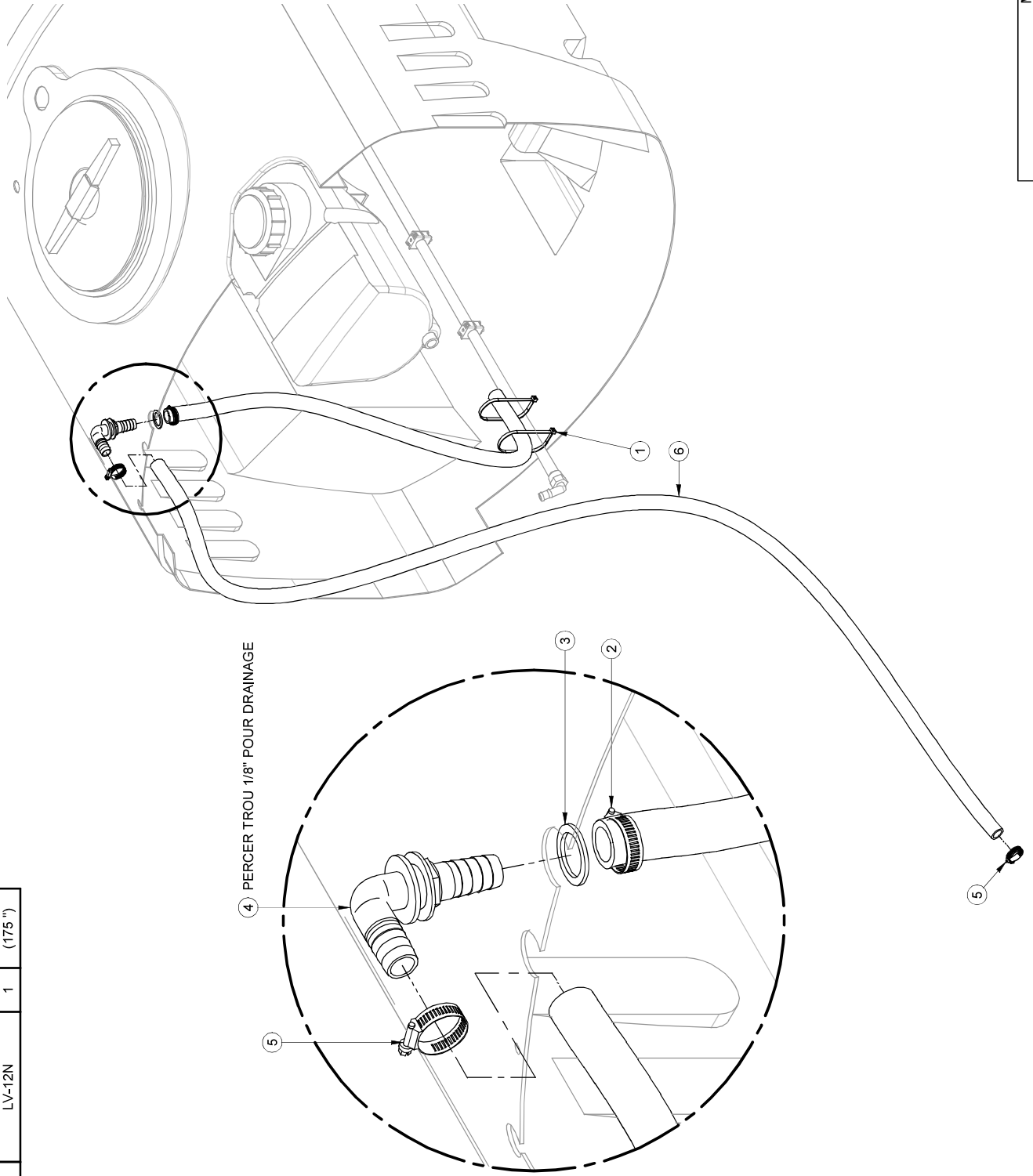

2007/10/30	MS-RET1.asm	Pg:1-1
MS-RET1.dft	Rev: 0	Sheet 1

#	Ref.	Q.	"
9	LV-1142N	1	(57")
10	LV-1142N	1	(106-1/2")

#	Ref.	Q.
1	MP-250051	1
2	MP-G40005	1
3	MP-205050	1
4	MP-1165331	1
5	MP-1065301	1
6	DA-SHAS24	1
7	DA-HS24	2
8	AU-L141200M	2

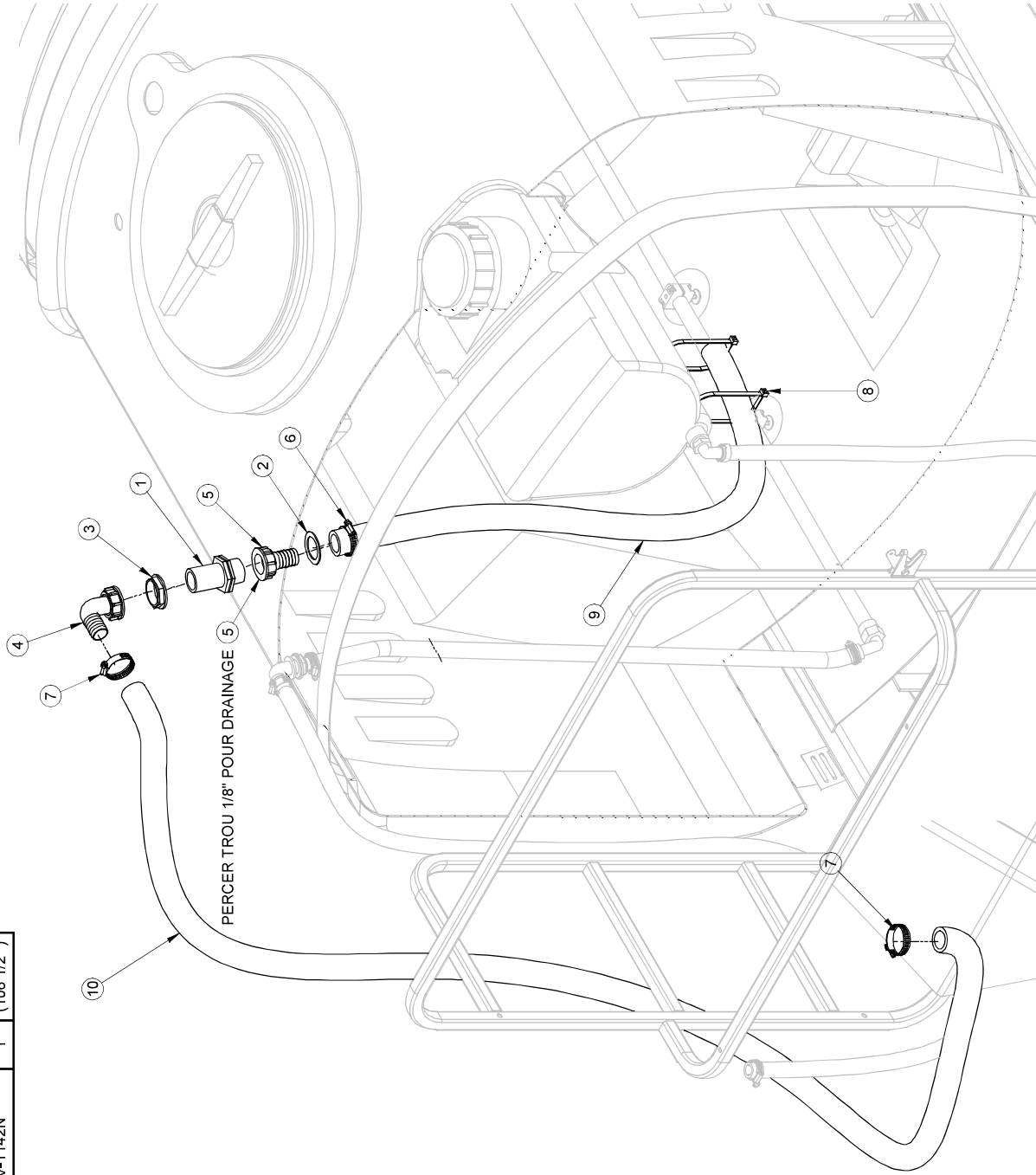

2008/03/25	MS-RET114R1.asm	Rev. 0	Pg:1-1
MS-RET114R1.dft			Sheet 1

#	Ref.	Q.
1	JB-DC2PG40	1
2	BJ-V20207	1
3	NO-62288	1
4	BJ-SL20045	1
5	RA-5042P	1
6	JB-M2000NY	1
7	MP-504019	1
8	JB-SE200NY	1

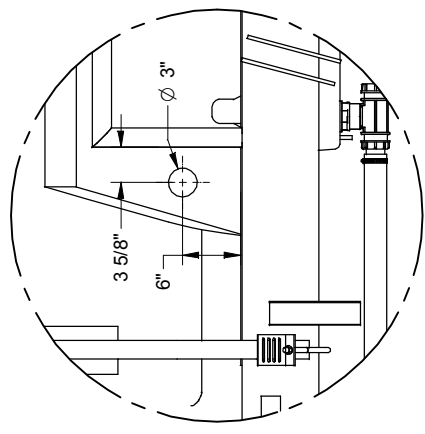
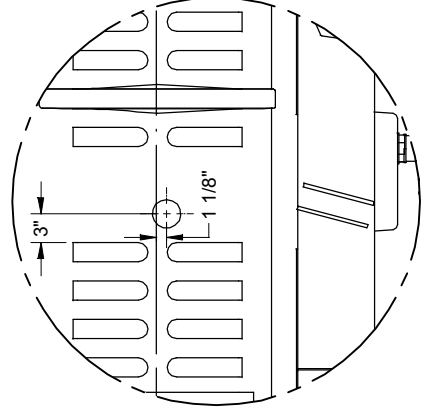
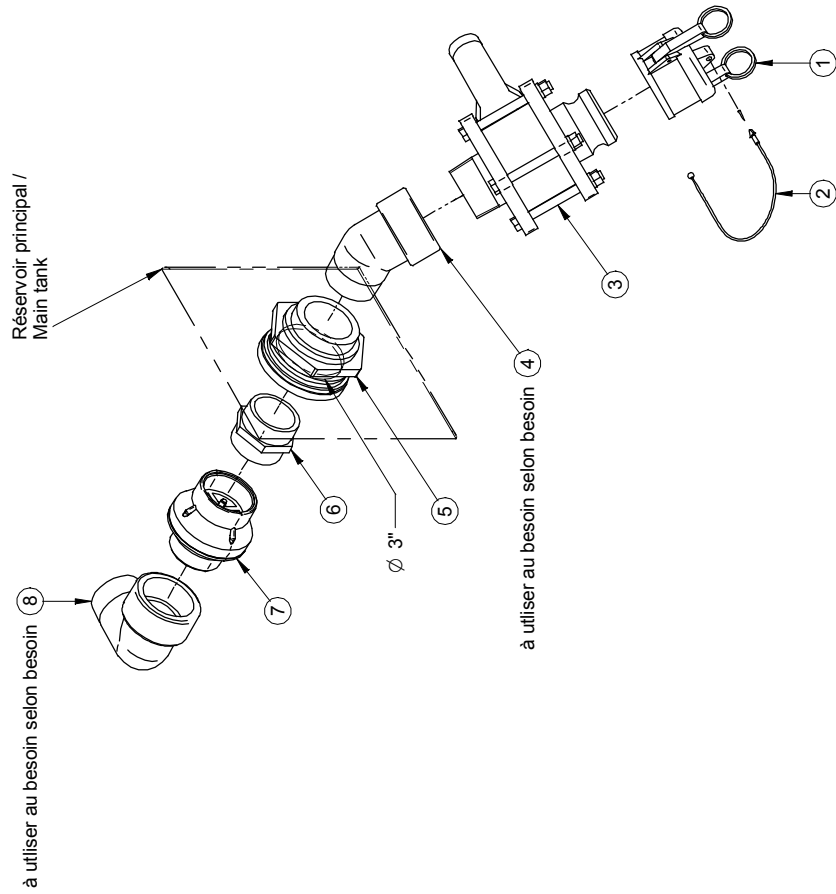

2009/03/20	RE-REMP2.asm	Pg:1-1
	Rev: 0	RE-REMP2
	RE-REMP2.dft	

#	Ref.	Q.	"
16	LV-1PVC	1	180"

#	Ref.	Q.
1	RA-5042P	1
2	JB-M2000NYL	1
3	JB-PBVH2002003	1
4	BJ-SL20045	1
5	JB-RB200100NY	1
6	JB-EL1010NY	1
7	MP-504019	1
8	JB-M2000NY	1
9	JB-SE200NY	1
10	MP-2200401	1
11	MP-1164251	1
12	JB-F2PG	1
13	JB-DC2PG40	1
14	BJ-V20207	1
15	DA-HS16	2
16	LV-1PVC	1

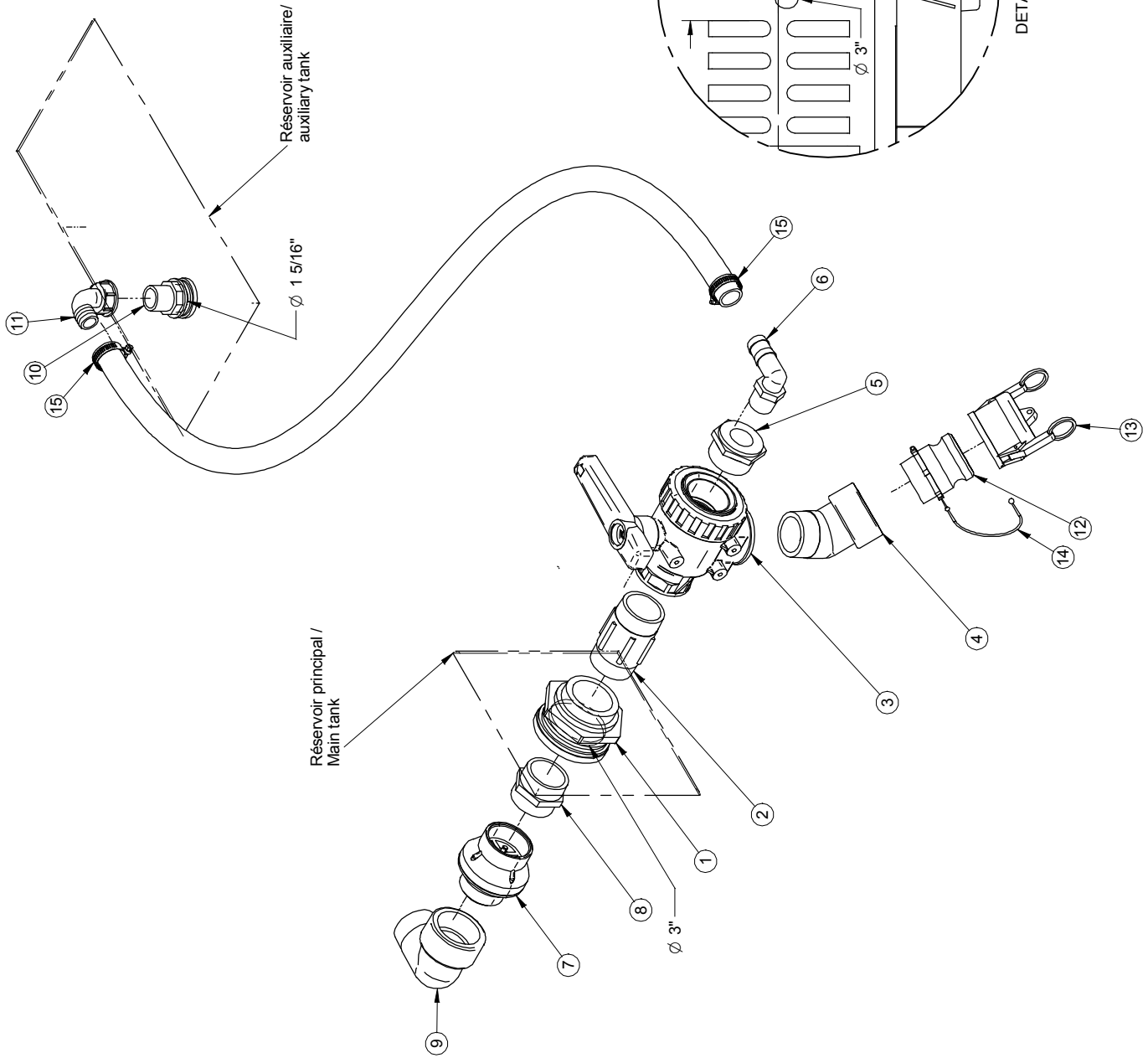

2007/09/24	RE-REMPP2RIN.asm	Pg:1-1
	Rev: 0	
	RE-REMPP2RIN.dft	Feuillet

#	REF.	Q.	L"
1	LV-1122N	1	132"

#	REF.	Q.
2	DA-SHAS32	2
3	BJ-M200150BRB	2
4	BJ-FC200	8
5	BJ-150G	8
6	RA-0630171894	1
7	BJ-M200CPG	1
8	RA-0630171793	1
9	BJ-M200CR	1
10	BJ-M200PLG075	2
11	JB-VMM0006NY	2
12	JB-M3400NY	1
13	JB-PBVH34343	1
14	JB-EL3434NY	1
15	BJ-MLST15050	1
16	AU-UBR516278412	2
17	BT-FW516	4
18	BT-LN516	4

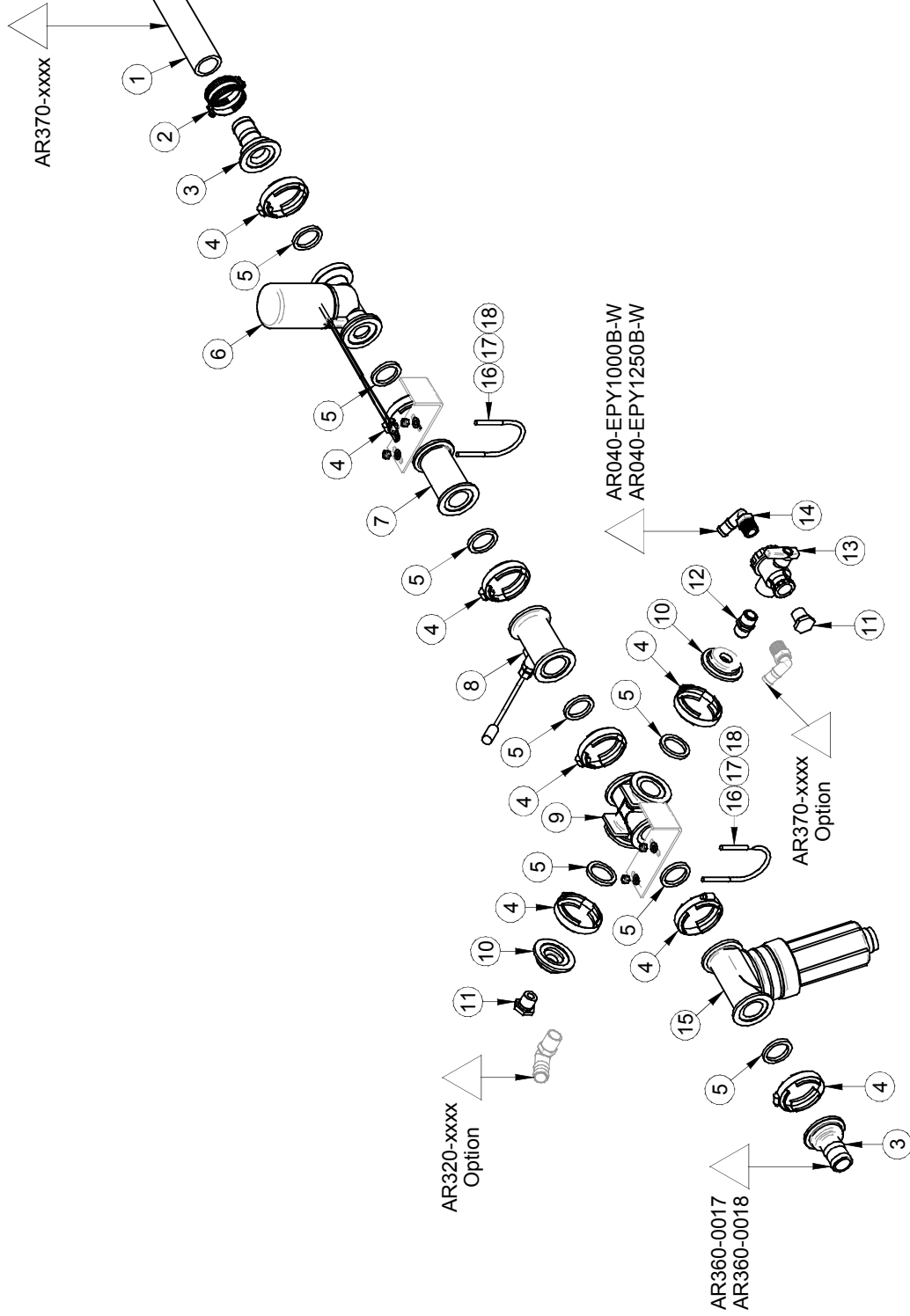

ENSEMBLE RINCEUR DE 20 GAL. POMPE CENTRIFUGE 20 GAL. TANK RINSE KIT, CENTRIFUGAL PUMP

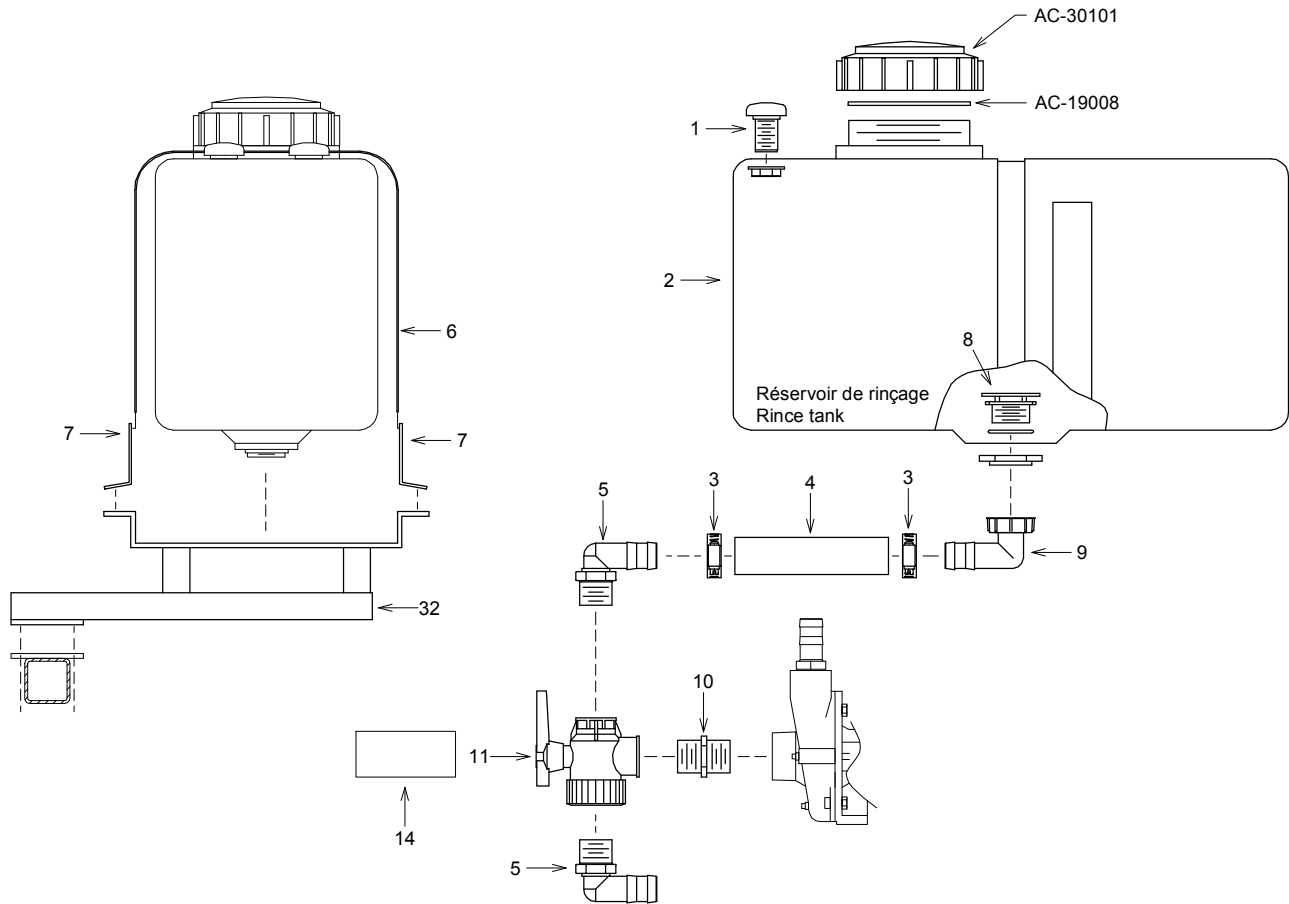

PULVÉRISATEUR MS Inc.	
MS SPRAYER Inc.	
\\PULVAG\OPTIONS\RIN20C112R3	
DATE: 2006-03-16	PAR/ BY: D.T.
REV:	PAR/ BY: #REV:
# REC.: MS-RIN20C112R3	
APP:	

APPROUVÉ LE: 2008-04-21 16:16:15 PAR: LANDIEG



MS Gregson Inc.

4300 rue Vachon, Drummondville QC J2B 6V4, Canada
Tél.: 819 474-1910 • Fax : 819 474-5317 • orders@msgregson.com

BOM

MS-RIN20C112AR3

REVISION

0

Desc. Française Ens. de rincage 75 l. 20 gal. pompe cen. 1 1/2" P300
English Desc. 0 gal. rinse tank with rinse nozzle, cen. pump, 3 pts

Réf.	Quantité	Produit	Description française	English Description
1	2.00	MP-504203	Reniflard 1" avec adapt de rés.	1" breather with tank adaptor
2	1.00	AC-SP0020LC	Rés. rect. 75 l, 20gal., 14"x14"x28", poly	Rect. tank 75 l, 20 gal., 14"x14"x28", poly
3	2.00	DA-HS24	Collet 1 1/16" x 2"	Collar 1 1/16" x 2"
4	4.00	LV-112PVC	Boyau vert renf., 1 1/2", 70 lb/po2, succion	Suction hose 1 1/2", green
5	2.00	JB-EL112NY	Adapt. coudé 1 1/2"mnpt x 1 1/2"hb céd.80 ny	Elbow adapt. 1 1/2"mnpt x 1 1/2"hb ced.80 ny
6	6.00	SN-TS198	Courroie sécurité noire 1 15/16" larg.	Polyester strap 1 15/16" width
7	4.00	MS-AC01	Attache courroie universel	Universal strap attachment
8	1.00	MP-5041061	Anti-vortex assy 1 1/2"	Anti-vortex assy 1 1/2"
9	1.00	MP-1166401	Adapt. coudé 1 1/2"pfbsp x 1 1/2"hb céd.40 ny	Elbow adapt. 1 1/2"hb x 1 1/2"fnpt ced.40 ny
10	1.00	JB-M1120NY	Mamelon court 1 1/2"mnpt x 1 1/2"mnpt céd.80 ny	Close nipple 1 1/2"mnpt x 1 1/2"mnpt ced.80 ny
11	1.00	JB-PBVH1121123	Valve à bille 3v 1 1/2"fnpt ny, joint EPDM	Ball valve 3v 1 1/2"fnpt ny, EPDM seal
14	1.00	AU-DECASPR1	Autocollant aspiration / succion	Decal suction/aspiration
32	1.00	MS-BRIN20PA	Bâti rinceur 20 gallons pour P1135PA	20 gallons rincer frame for P1135PA

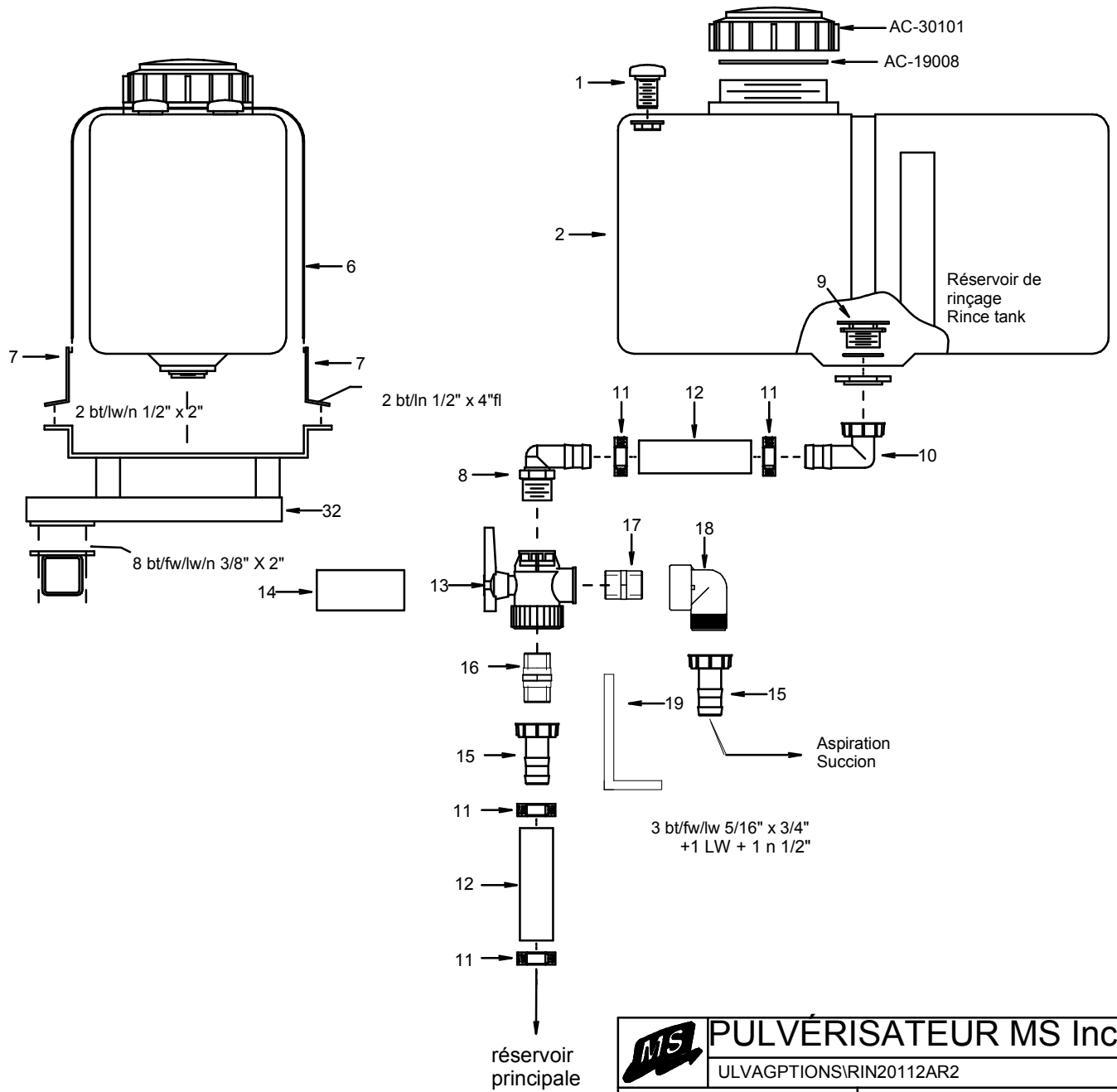

MS PULVÉRISATEUR MS Inc.		
ULVAGPTIONS\RIN20112AR2		
DATE: 2007-01-14	PAR: G.L.	
REV:	PAR:	#REV:
TITRE: ENS. RINCEUR DE 20 GAL, POMPE A MEMBRANE		
# REC.: RE-RIN20112AR2		
		APP:



Desc. Française **Ens. de rinçage 75 l. 20 gal. pompe diap. 1 1/2" pour P300**
 English Desc. **20 gal rince tank kit, 1 1/2" plumbing**

Réf.	Quantité	Produit	Description française	English Description
1	2.00	MP-504203	Reniflard 1" avec adapt de rés.	1" breather with tank adaptor
2	1.00	AC-SP0020LC	Rés. rect. 75 l, 20gal., 14" x14"x28", poly	Rect. tank 75 l, 20 gal., 14" x14"x28", poly
6	6.00	SN- TS198	Courroie sécurité noire 1 15/16" larg.	Polyester strap 1 15/16" width
7	4.00	MS-AC01	Attache courroie universel	Universal strap attachment
8	1.00	JB-EL112N Y40	Adapt. coudé 1 1/2" mnpt x 1 1/2"hb céd.40 ny	Elbow adapt. 1 1/2" mnpt x 1 1/2"hb ced.40 ny
9	1.00	MP-5041061	Anti-vortex ass y 1 1/2"	Anti-vortex assembly 1 1/2"
10	1.00	MP-1166401	Adapt. coudé 1 1/2"pfbps x 1 1/2"hb céd.40 ny	Elbow adapt. 1 1/2"hb x 1 1/2"fnpt ced.40 ny
11	4.00	DA-HS24	Collet 1 1/16" x 2"	Collar 1 1/16" x 2"
12	7.00	LV-112PVC	Boyaux vert renf., 1 1/2", 70 lb/po2, succion	Suction hose 1 1/2", green
13	1.00	JB-PBVH1121123	Valve à bille 3v 1 1/2"fnpt ny, joint EPDM	Ball valve 3v 1 1/2"fnpt ny, EPDM seal
14	1.00	AU-DECR INC85	Autocollant réservoir rinçage 85 gal. R3850	Decal / rince-tank, 85 gal. R3850
15	1.00	MP-1066401	Adapt. droit 1 1/2"pfbps x 1 1/2"hb céd.40 ny	Straight adapt. 1 1/2"fnpt x 1 1/2"hb ced.40 ny
16	1.00	JB- IMB1212NY	Adapt. droit 1 1/2" mnpt x 1 1/2"hb céd.80 ny	Straight adapt. 1 1/2" mnpt x 1 1/2"hb ced.80 ny
17	1.00	JB- M1120NY	Mamelon court 1 1/2" mnpt x 1 1/2" mnpt céd.80 ny	Close nipple 1 1/2" mnpt x 1 1/2" mnpt ced.80 ny
18	1.00	JB-SE112N Y40	Adapt. coudé 1 1/2" mf cedule 40	Elbow 1 1/2" mf cedule 40
19	1.00	MS-BR IN20PA1	Fixation valve bâti rinceur 20 gallons	Bracket valve 20 gallons rince
32	1.00	MS-BR IN20PA	Bâti rinceur 20 gallons pour P1135PA	20 gallons rinceur frame for P1135PA

#	Ref.	Q.	"
1	AS-341N	1	(125 1/2")
4	MP-2500301	1	
5	MP-1163201	1	
7	JB-552703/418POM	1	
8	DA-HS12	2	

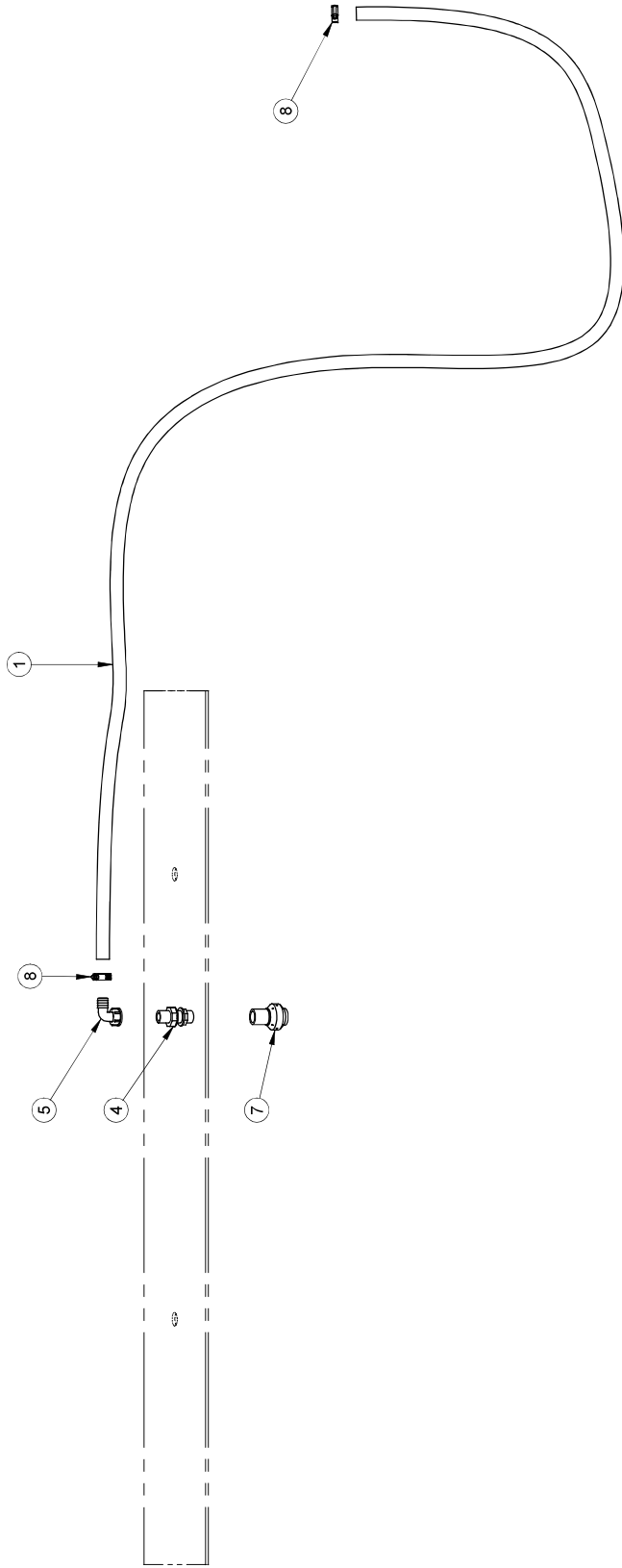

#	REF.	Q.	L"
6	AS-341N	1	(125 1/2")

#	REF.	Q.
1	DA-HS12	2
2	JB-EL3434NY	1
3	MP-1163201	1
4	MP-2500301	1
5	JB-552703418POM	1

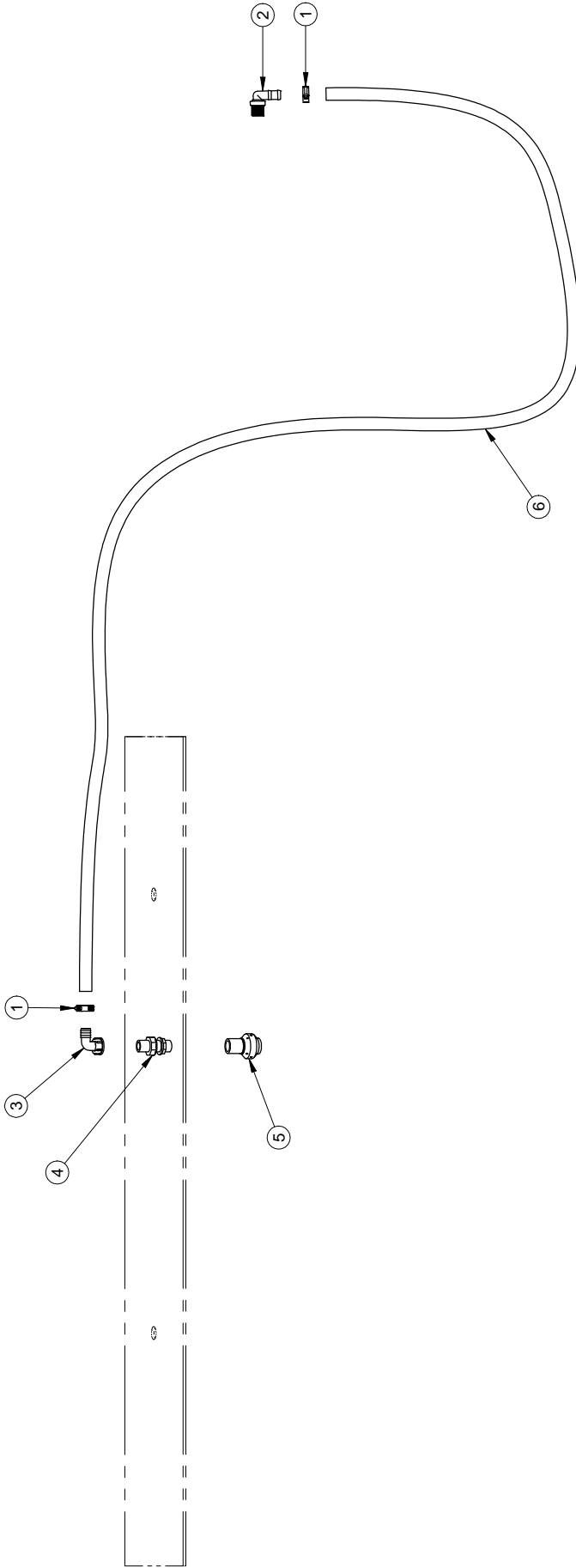

1- LES VALEURS SONT EN
POUCES SAUF SI SPECIFIÉ
UNITS ARE IN INCHES
UNLESS OTHERWISE SPECIFIED
2- TOLERANCES GENERALES
Frac.: ± 1/16"
Dec.: ± 0.01"
X.X: ± 0.1"
X.XX: ± 0.005"
X.XXX: ± 0.0005"



AVIS: L'information contenue a été
fournie par RAD TECHNOLOGIES INC. qui se
réserve tous les droits de propriété,
intellectuelle, commerciale, industrielle,
communication, fabrication et autres
droits de reproduction. Toute réimpression
sans autorisation écrite de RAD
TECHNOLOGIES INC. est interdite.
Use, sale, manufacturing and/or
reproduction rights reserved.

FEUILLE / SHEET #
AR310-0006
DESCRIPTION
Ensemble de 1 buse de rinçage
#DESSIN / DRAWING #
AR310-0006

DATE CREATION	2014/06/10	DATE CREATION	2014/06/10	DATE CREATION	2014/06/10	DATE CREATION	2014/06/10
CREATEUR / CREATOR	trudelj	CREATEUR / CREATOR	trudelj	CREATEUR / CREATOR	trudelj	CREATEUR / CREATOR	trudelj
REVISION	0	REVISION	0	REVISION	0	REVISION	0
ECHELLE / SCALE	1:20	ECHELLE / SCALE	1:20	ECHELLE / SCALE	1:20	ECHELLE / SCALE	1:20

Rev	Description	Date	Approbation
-----	-------------	------	-------------

#	Ref.	Q.	"
1	BE-183PVC	1	(40 ")
3	AU-DECOD	1	
4	MP-ESC0010	1	
5	AU-2881164ND	1	
6	MT-11829	1	
7	DO-761232	2	
8	AU-3601068ND	1	12 "
9	BE-183PVC	1	6 "
10	AU-TUBERET38	2	
11	AU-343058VM	2	

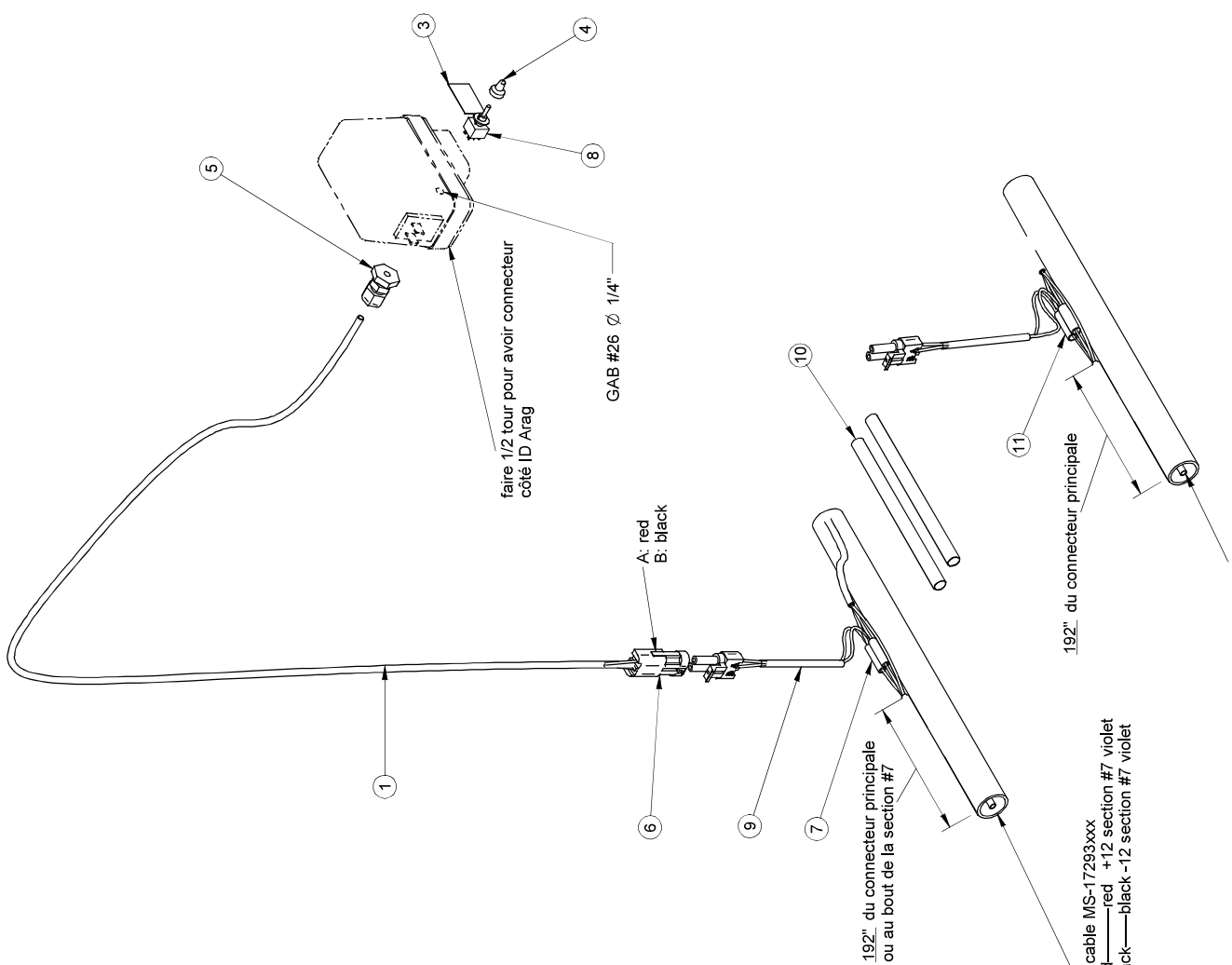
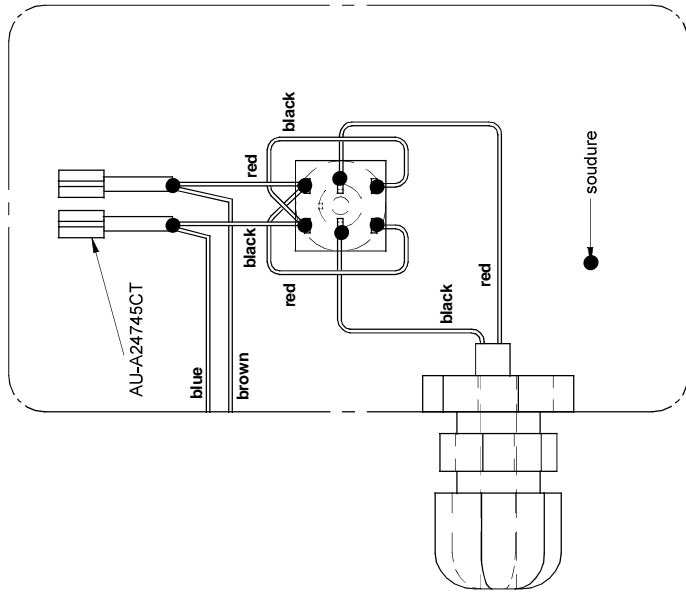

#	Ref.	Q.
1	AC-SP0005SQ	1
2	MP-2500Z11	2
3	JB-FC1200NY40	1
4	JB-SE12NY	1
5	MS-JETTRINC12	1
6	MP-1636044	1
7	AU-94015	1
8	BT-LN14SS	4
9	BT-141SS	4

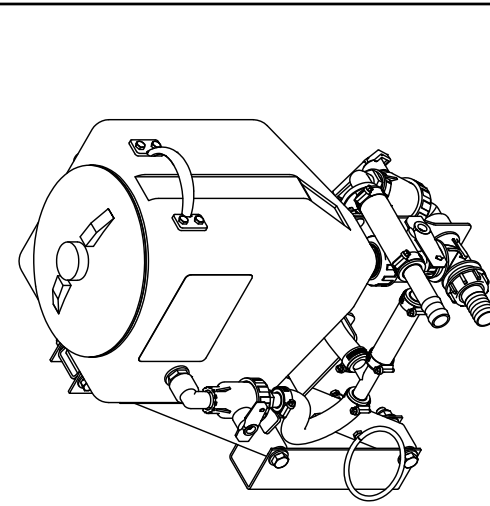

Gabarit AG04

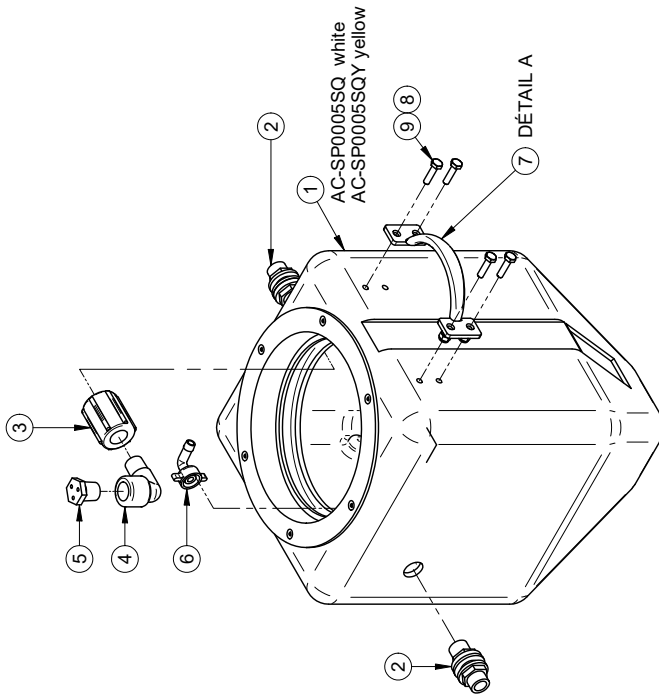
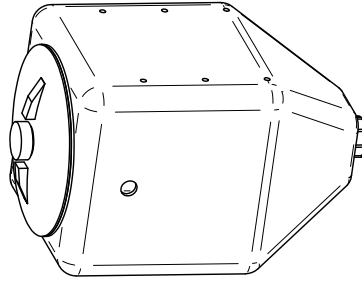

Gabarit AG03

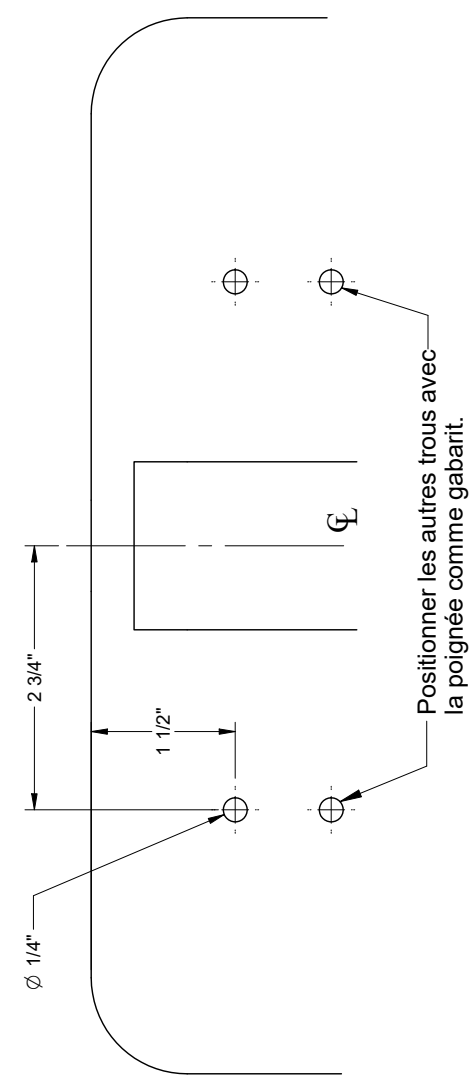
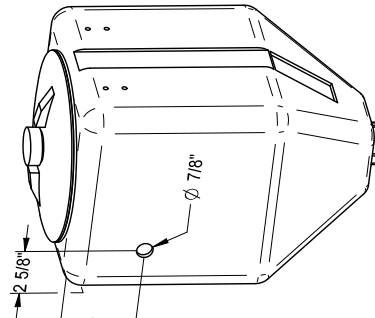

DETAIL A

Rev	Description	Date	Approbation
Rev 2	Nouvel tamis de filtration A320-0010, A320-0009 Alu et A320-0002	2019-11-08 [trudej]	

1- LES VALEURS SONT EN POUCE SAUF SI SPECIFIÉ	VALUES ARE INCHES UNLESS OTHERWISE SPECIFIED
2- TOLERANCES GENERALES	GENERAL TOLERANCES
Frac.: ± 1/16"	Frac.: ± 0.01"
X.XX: ± 0.01"	X.XX: ± 0.01"
X.XXX: ± 0.005"	X.XXX: ± 0.005"

AVIS: L'information ci-incluse a été fournie par le fabricant et MS GREGGON n'assume aucune responsabilité en ce qui concerne les droits de propriété, licence, brevet, droits de reproduction, etc. MS GREGGON, qui réserve all patent rights therein, assumes no liability for information, fabrication or reproduction thereof.	MS GREGGON
--	------------

# FEUILLE / SHEET #	MS-PREM5GPRD	DATE CREATION	2006-12-15	CREATEUR / CREATOR	lanolieg	REVISION DATE	2019-11-08	PAGE	1 of 3
DESCRIPTION	Pré-mélangeur 19 L (5 gal) avec relevage		REVISION PAR / BY	trudej	ECHELLE / SCALE	1:10	REVISION	2	
# DESSIN / DRAWING #	MS-PREM5GPRD								

#	REF.	Q.	L"
35	LV-342N300	1	3 1/2"
36	LV-12N300	1	4 1/2"
37	LV-342N300	1	9"
38	LV-342N300	1	17 1/2"

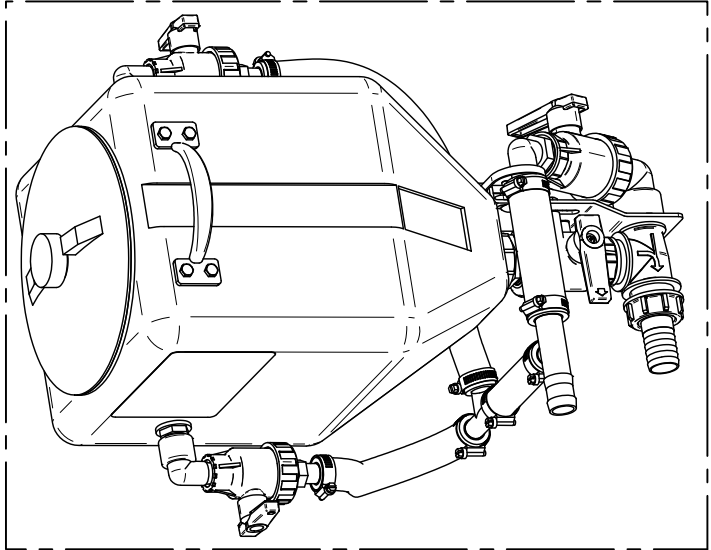
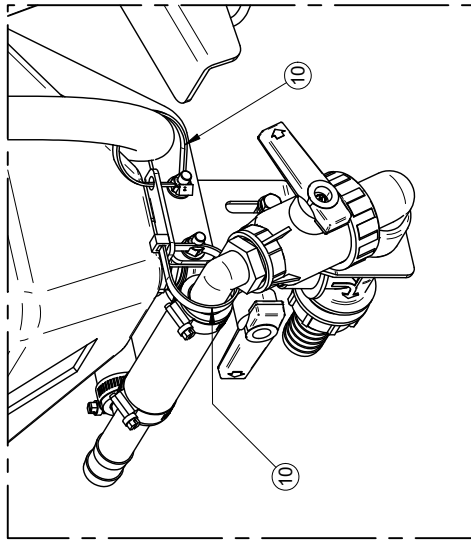

#	REF.	Q.
10	AU-L141200M	4
11	JB-SE12NY	2
12	MP-S301200PP	2
13	JB-IMB0406NY	2
14	DA-SHAS12	6
15	JB-M1140NY	1
16	DA-SHAS16	2
17	JB-EL1010NY	1
18	MP-S301320PP	1
19	JB-SE100NY	1
20	BT-51634SS	6
21	BT-LW516SS	6
22	BT-FW516SS	6
23	A320-0009	1
25	MP-135542	1
26	MP-1066301	1
27	MP-S301400PP	1
28	BJ-HBT100075	1
29	JB-T34NY	1
30	AU-DECPREMR2	1
31	A320-0010	1
32	BT-CAR5161	2
33	BT-LN516	2
34	BT-FW516	2

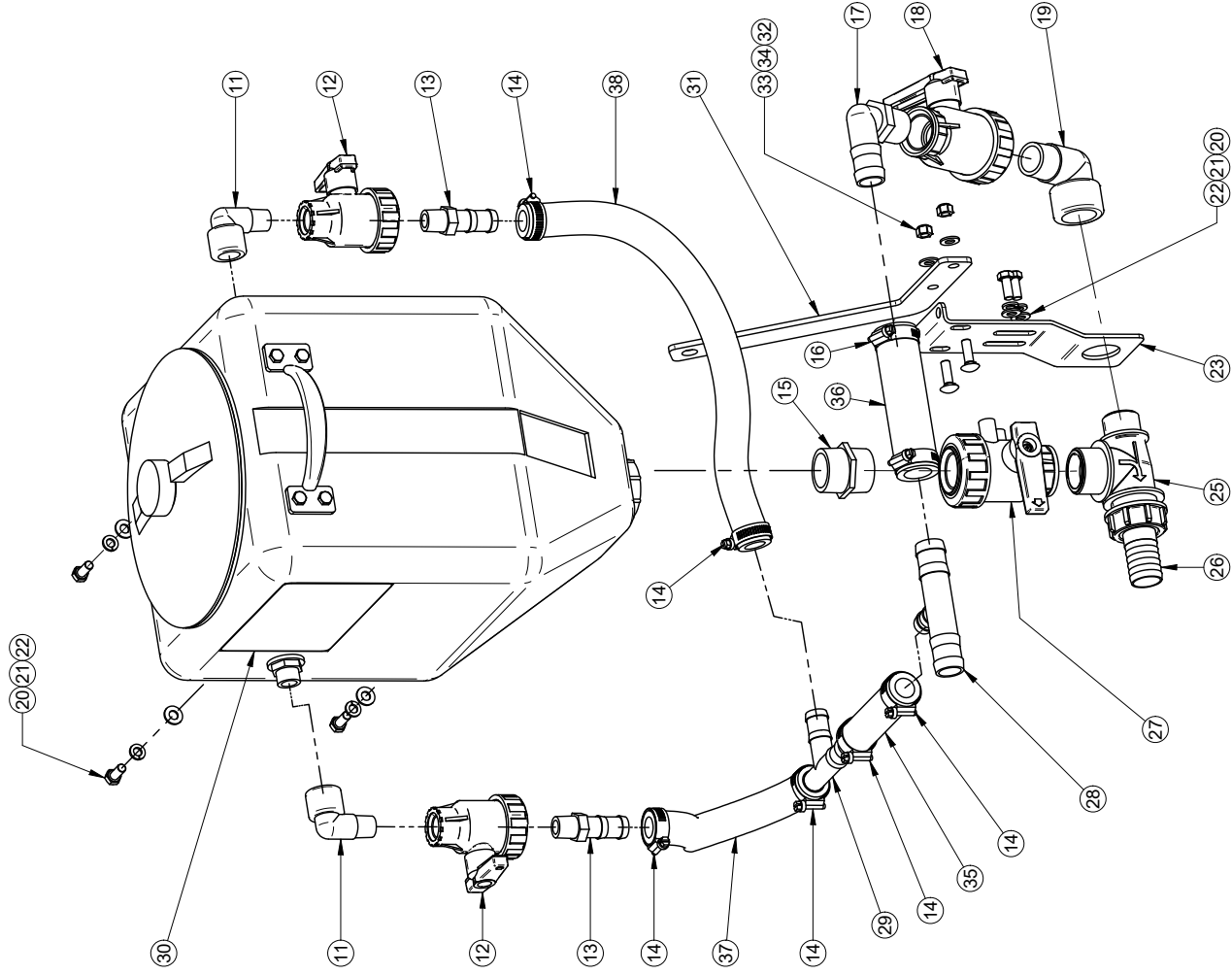

1-LES VALEURS SONT EN POUCES SAUF SI SPECIFIÉ
 UNITS
 2-GENERAL TOLERANCES
 Fina.: ± 1/16"
 X.XX: ± 0.01"
 X.XXX: ± 0.005"



AVIS: L'information contenue est émise sous réserve de la propriété, licence, droits de reproduction, etc. et n'est pas destinée à être utilisée sans autorisation écrite de MSG GREGSON, qui réserve all patent rights therein.

FEUILLE / SHEET #
 MS-PREM5GPRD-001
 DESCRIPTION
 Pré-mélangeur 19 L (5 gal) avec relevage
 #DESSIN / DRAWING #
 MS-PREM5GPRD

DATE CREATION	CREATEUR / CREATOR	REVISION DATE	PAGE
2006-12-15	lanlog	2019-11-08	2 of 3
		trudej	
		ECHELLE / SCALE	REVISION
		1:5.33	2

Rev	Description	Date	Approbation
Rev 2	Modifier barre de fixation A320-0010, A320-0009 ainsi A320-0002	2019-11-08 [trudej]	

#	Ref.	Q.
39	BT-12412	1
40	BT-FW12	16
41	MS-IBSPF	1
42	BT-LN12	4
43	BT-12312	2
44	MS-IBSPA	1
45	MS-IBSPB	1
46	MS-AN353	1
47	BT-FW14	2
48	BT-38312	1
49	BT-N716	1
50	BT-LN14	1
51	AU-RC34	1
52	MS-IBSPD	1
53	BT-LN38	1
54	BT-FW38	2
55	BT-8321	1
56	SN-315253	1
57	BT-FW316SS	1
58	BT-LN832SS	1
59	A320-0003	2
60	BT-124	1

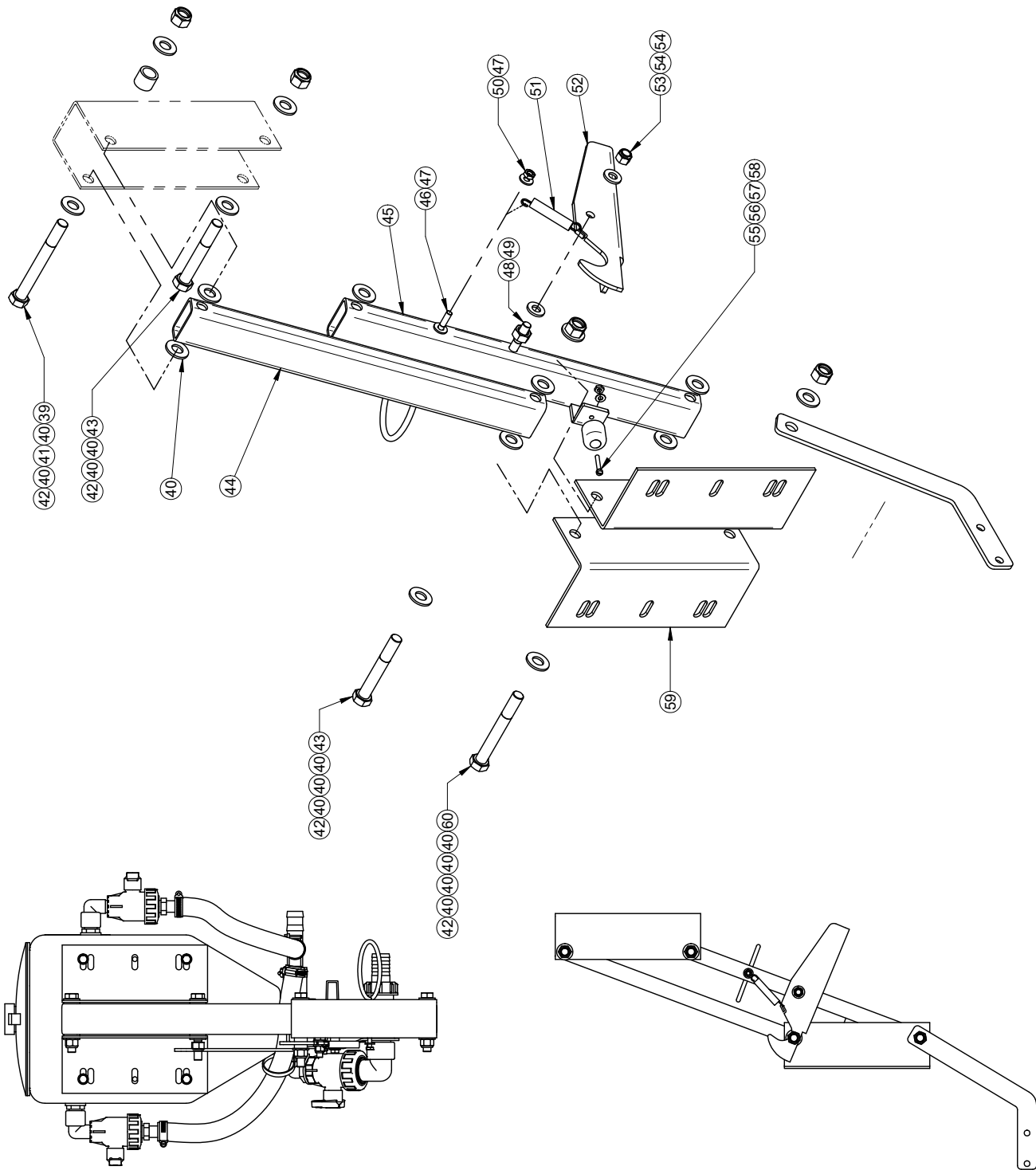

<p>AVIS: L'information ci-dessus a été fournie par le fabricant et MS GREGSON n'assume aucune responsabilité en ce qui concerne les droits de propriété, licence, brevet, droits de reproduction, etc. MS GREGSON, who reserves all patent rights therein.</p>	<p># FEUILLE / SHEET # MS-PREM5GPRD-002</p>	<p>DATE CREATION 2006-12-15</p>	<p>CREATEUR / CREATOR Iantolieg</p>	<p>REVISION PAR / BY trudej</p>	<p>REVISION DATE 2019-11-08</p>	<p>PAGE 3 of 3</p>
<p>1- LES VALEURS SONT EN POUCES SAUF SI SPECIFIÉ VALUES ARE INCHES UNLESS OTHERWISE SPECIFIED 2- TOLERANCES GENERALES Frac.: ± 1/16" X.X: ± 0.01" X.XX: ± 0.1" X.XXX: ± 0.005"</p>	<p>MS GREGSON</p>					
<p>Rev 2 - Nouvel barre de fixation A320-0010, A320-0009 ainsi A320-0002</p>	<p>Date: 2019-11-08 [trudej]</p>	<p>Approbation:</p>				
<p>Rev</p>	<p>Description</p>	<p>MS GREGSON</p>				

#	Ref.	Q.	L"
1	MS-901654PR	1	
3	BT-38112	2	
4	BT-38212	1	
5	BT-383	1	
6	BT-LW38	2	
7	BT-N38	2	
8	BT-516134	2	
9	BT-LW516	2	
10	BT-FW516	2	
11	BT-N516	2	
12	AU-1251	8	8"

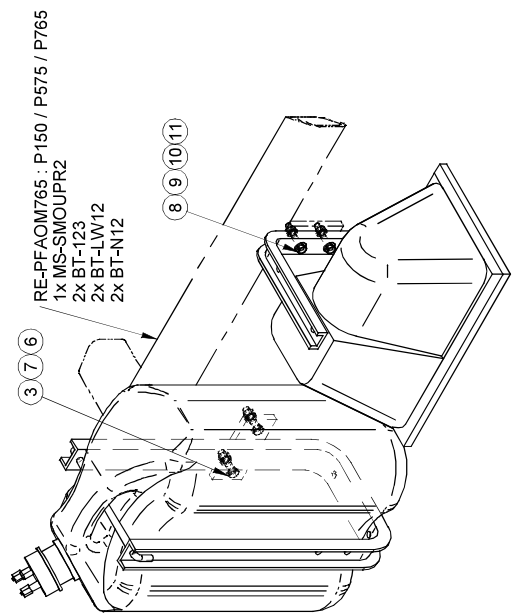
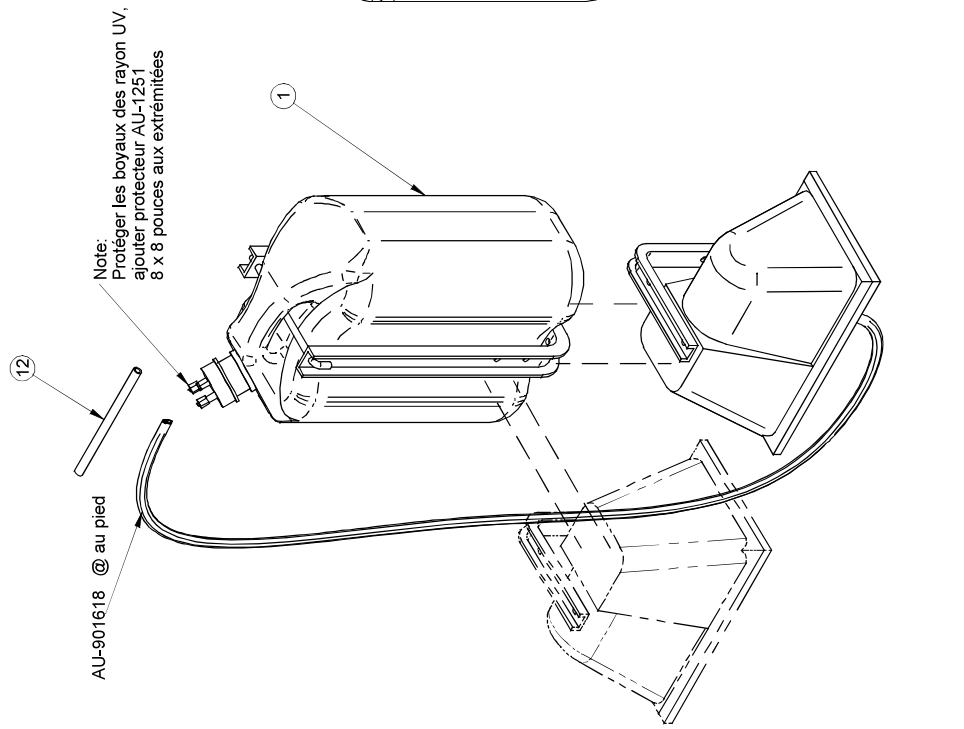

#	Ref.	Q.	"
1	AU-901618	1	1080 "
2	AU-1251	4	8 "
4	BT-14112	4	
5	BT-LW14	4	
6	BT-N14	4	
7	MS-PDMM1	2	
8	BT-5162	2	
9	BT-516112	2	
10	BT-LW516	4	
11	BT-N516	4	
12	AU-L141200M	4	

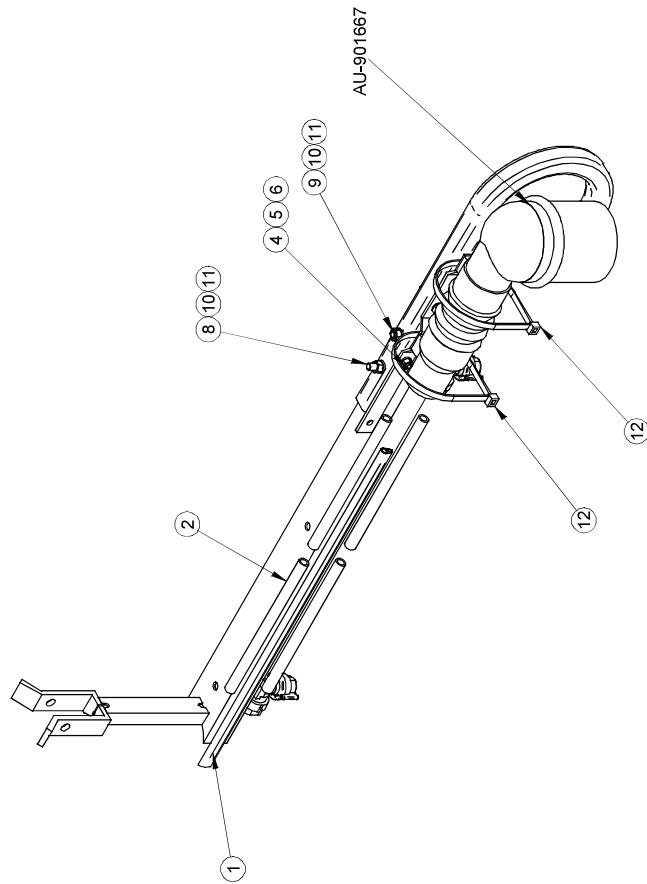

#	Ref.	Q.	"
1	AU-901618	1	1920 "
2	AU-1251	4	8 "
4	BT-14112	4	
5	BT-LW14	4	
6	BT-N14	4	
7	AU-L141200M	4	

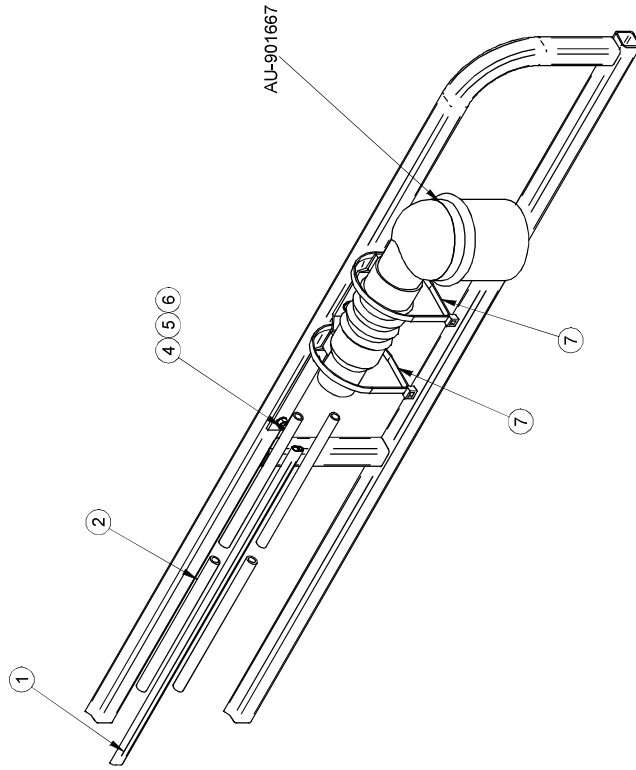

#	Ref.	Q.
1	RE-SB25037	1
2	RE-ACM037	1
3	RE-FU18A18037	1

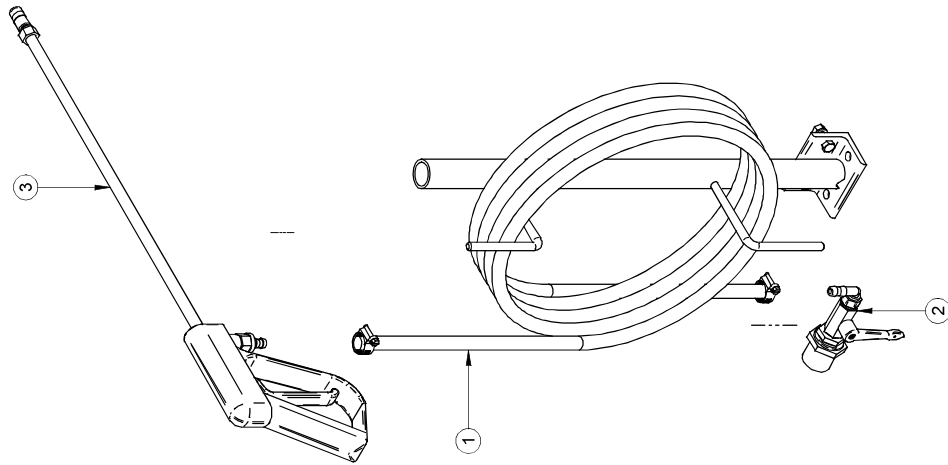

2008/02/26	RE-FU25R6CM.asm	Rev. 0	Pg:1-1
	RE-FU25R6CM.dft		RE-FU25R6CM

#	Ref.	Q.	L"
1	AS-381N	1	300 "

#	Ref.	Q.
2	MS-SBF	1
3	DA-HS6	2
4	BT-5161	2
5	BT-LW516	2
6	BT-N516	2

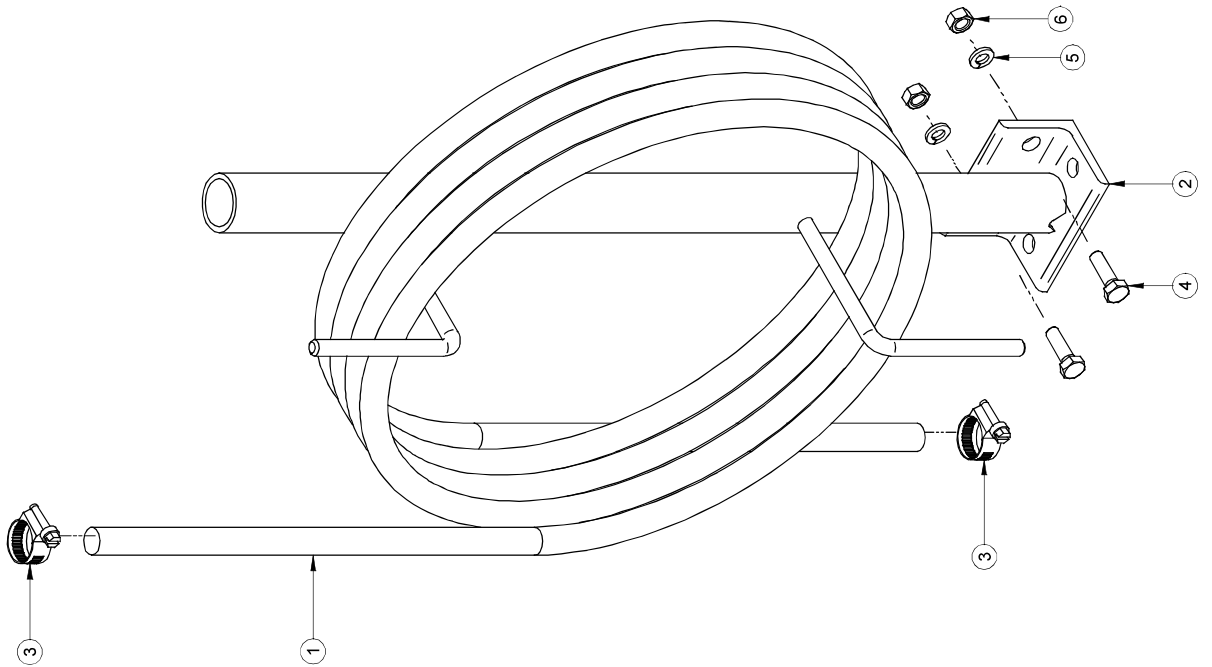

2008/02/26	RE-SB25037.asm	Rev. 0	Pg:1-1
	RE-SB25037.dft		RE-SB25037

#	Ref.	Q.
1	JB-RB10034NY	1
2	JB-RMM0406NY	1
3	MP-S301200PP	1
4	JB-EL1238NY	1

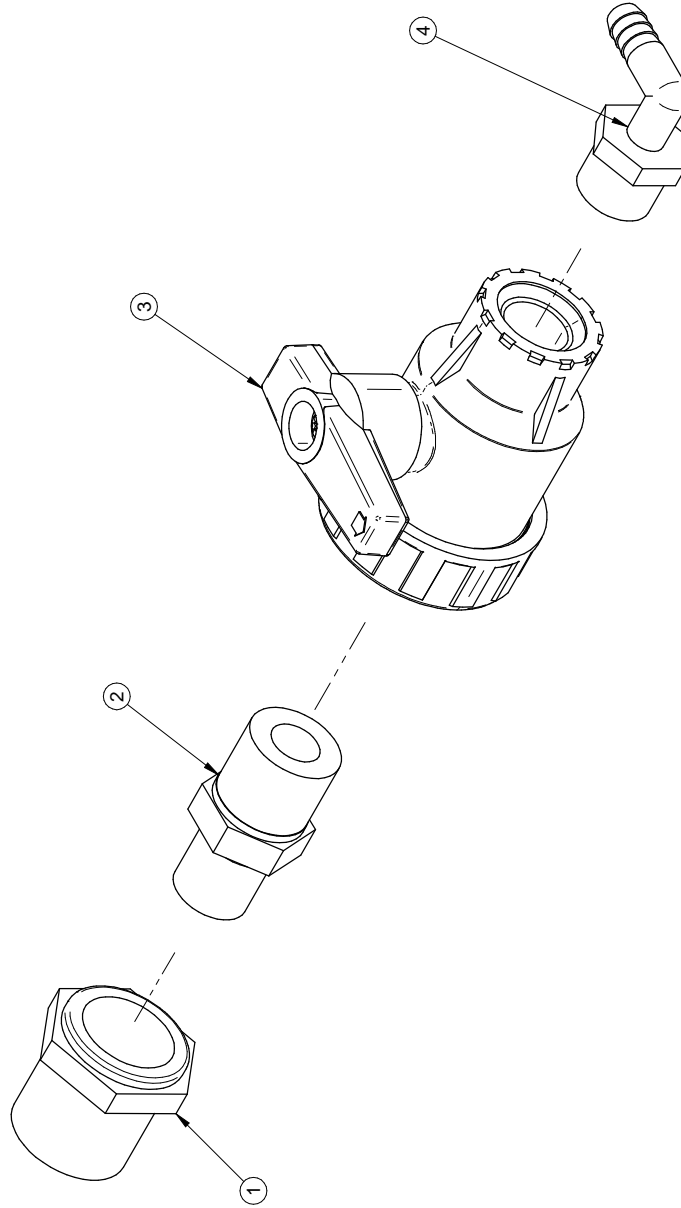

AVIS	Information c-incluse a 46	# FEUILLE / SHEET #	DATE CREATION	CREATEUR / CREATOR	REVISION DATE	PAGE
1- LES VALEURS SONT EN POUCES SAUF SI SPECIFIE VALUES ARE INCHES UNLESS SPECIFIED OTHERWISE 2- TOLERANCES GENERALES TOLERANCES GENERALES Frac.: ± 1/16" X.X: ± 0.1" X.XX: ± 0.01" X.XXX: ± 0.005"	MS GREGSON M S G R E G S O N	RE-ACM037	2023-03-15	fogaingf	2023-03-15	1 of 1
		DESCRIPTION			REVISION PAR / BY	
		Adaptateur de boyau 3/8" pour contrôle modulaire			fogaingf	
		#DESSIN / DRAWING #			ECHELLE / SCALE	
		RE-ACM037			1:2	REVISION
						1

Rev	Description	Date	Approbation
1	JB-RMM0406NY et al. JB-RMM0306NY et al. MP-S301200PP et al. JB-086FB 1", JB-EL1238NY et al.	2023/03/15	Fogaingf

#	Ref.	Q.
1	MS-FU18A18	1
2	JB-IMB0303BRSW	1

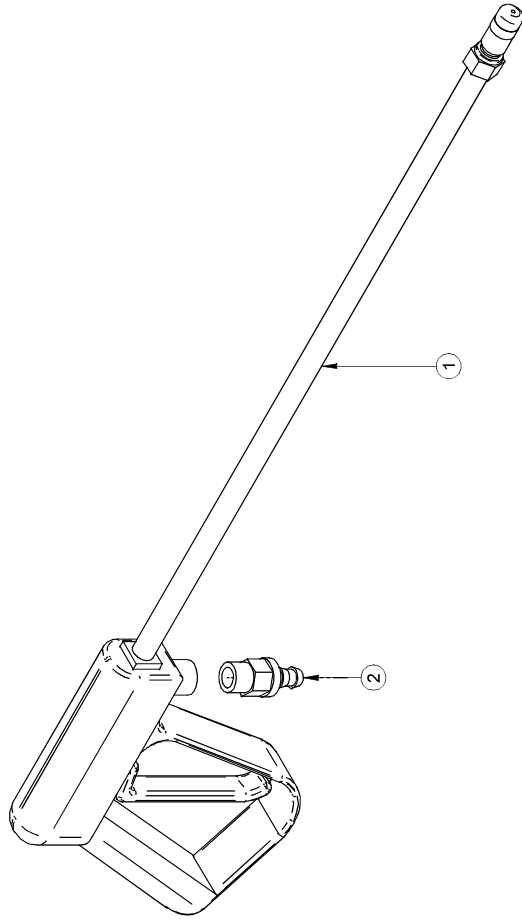

2008/02/19	RE-FU18A18037.asm	Rev. 0	Pg:1-1
	RE-FU18A18037.dft		RE-FU18A18037

POMPE CENTRIFUGE AVEC FILTREUR CENTRIFUGAL PUMP WITH FILTER

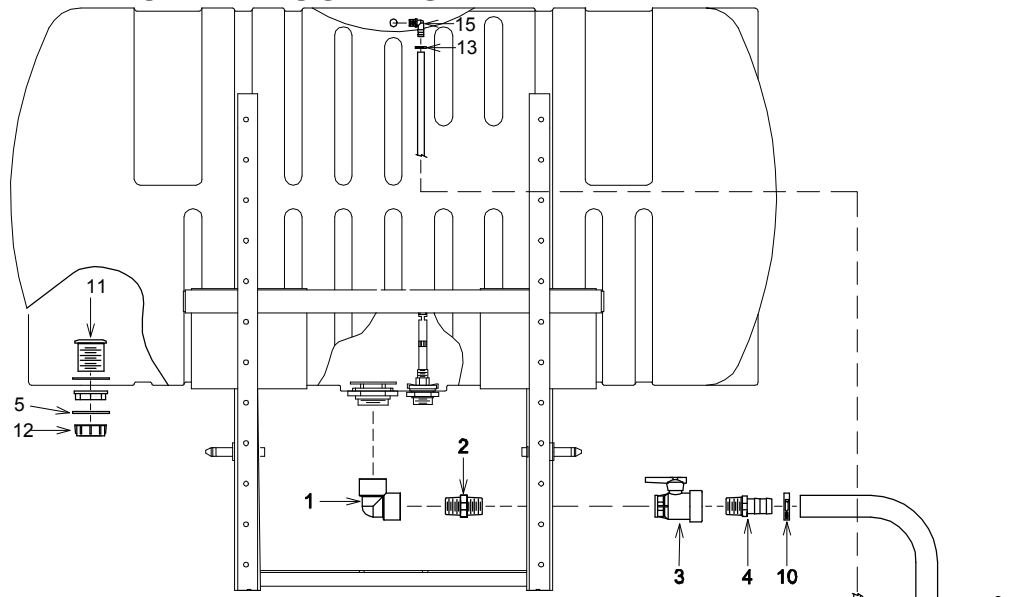

RE-PCENHY

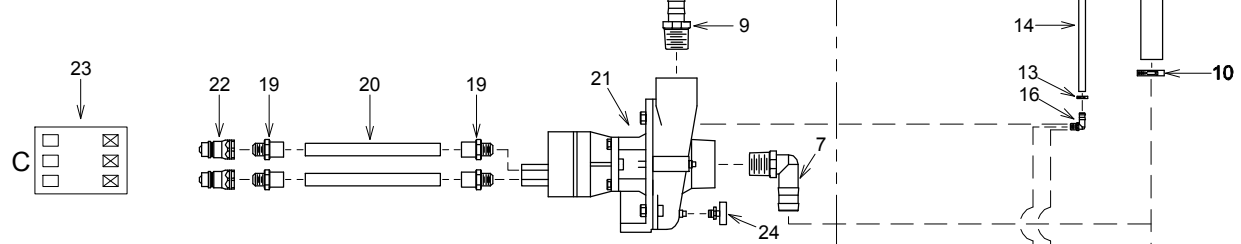

RE-PCEN

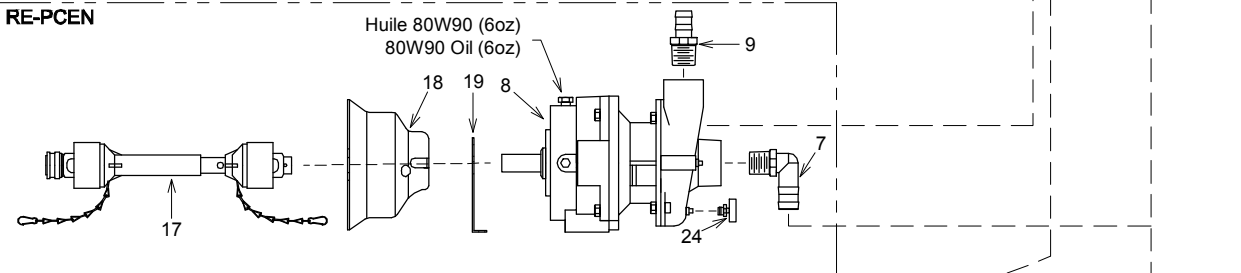

RE-PCEN9403

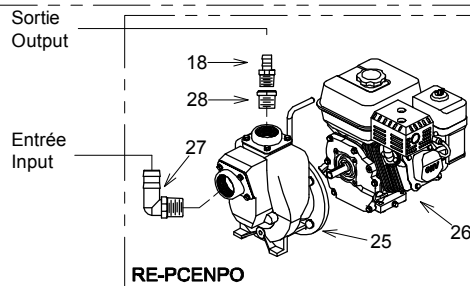
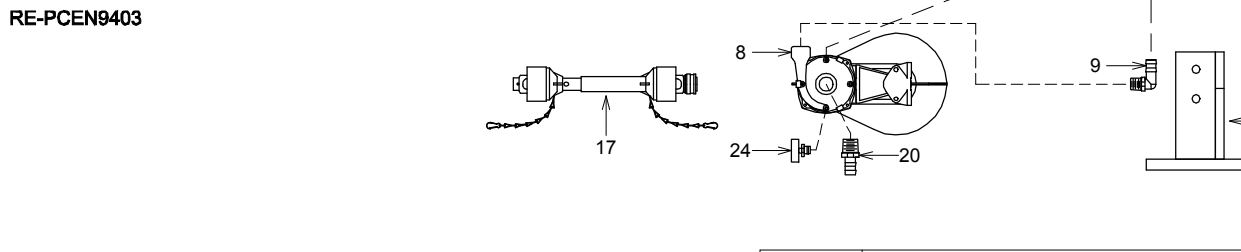

PULVÉRISATEUR MS Inc.
MS SPRAYER Inc.

PLAN MONTAGE\PulvAG\Porte\Pompe\PCEN

DATE: 1999-12-04

PAR/ BY: G.L.

REV: 2006-03-21

PAR/ BY: D.T.

#REV: 1

REC.: RE-PCEN

RE-PCEN9403

RE-PCENHY / RE-PCENPO

APP:

APPROUVE LE: 2006-03-22 09:07:20 PAR: LANDIEG

Desc. Française **Ens. de pompe 9303chm4c avec filtre 1 1/2" pulv. 3pt**
 English Desc. **Hyd. cent pump 1 1/2" suc exit 1 1/4"**

Réf.	Quantité	Produit	Description française	English Description
1	1.00	JB-LL112NY	Adapt. coudé 1 1/2"fnpt x 1 1/2"fnpt céd.80 ny	Elbo w adapt. 1 1/2"fnpt x 1 1/2"fnpt ced.80 ny Close
2	1.00	JB- M1120NY	Mamelon court 1 1/2" mnpt x 1 1/2" mnpt céd.80 ny	nipple 1 1/2" mnpt x 1 1/2" mnpt ced.80 ny Ball valve 2v 1
3	1.00	MP-S301500PP	Valve à bille 2v 1 1/2"fnpt n y, joint EPDM	1/2"fnpt n y, EPD M seal
4	1.00	JB- IMB1212NY	Adapt. droit 1 1/2" mnpt x 1 1/2"hb céd.80 ny	Straight adapt. 1 1/2" mnpt x 1 1/2"hb ced.80 ny
5	1.00	MP-G40004	Gas ket 1"	1" gas ket
6	3.00	LV-112PVC	Boyau vert renf., 1 1/2", 70 lb/po2, succion	Suction hose 1 1/2", green
7	1.00	JB-EL112NY	Adapt. coudé 1 1/2"mnpt x 1 1/2"hb céd.40 ny	Elbo w adapt. 1 1/2"hb x 1 1/2"mnpt ced.40 ny Straight
9	1.00	JB- IMB1008NY	Adapt. droit 1 1/4" mnpt x 1"hb céd.80 ny	adapt. 1 1/4" mnpt x 1"hb ced.80 ny
9	1.00	JB- IMB1012NY	Adapt. droit 1 1/4" mnpt x 1 1/2"hb céd.80 ny	Straight adapt. 1 1/4" mnpt x 1 1/2"hb ced.80 ny
10	2.00	DA-HS24	Collet 1 1/16" x 2"	Collar 1 1/16" x 2"
11	1.00	MP-2200601	Adapt. droit 1 1/2" mnpt céd.40 ny	Straight adapt. 1 1/2" mnpt ced.40 ny
12	1.00	MP-210060 2.00	Capuchon 1 1/2"fnpt céd.40 ny	Plug 1 1/2"fnpt ced.40 ny
13		DA-MH4	Collier de serrage 7/32" x 5/8"	Collar 7/32" x 5/8"
14	8.00	LV-142N	Boyau noir, 1/4", 200 lb/po2, 2 plis	Blac k hose, 1/4", 200 psi, 2 ply
15	1.00	JB-E MB0102BR	Adapt. coudé 1/8" mnpt x 1/4"hb céd.40 br	Elbo w adapt. 1/8" mnpt x 1/4"hb ced.40 br
16	1.00	JB-E MB0102BR	Adapt. coudé 1/8" mnpt x 1/4"hb céd.40 br	Elbo w adapt. 1/8" mnpt x 1/4"hb ced.40 br
19	4.00	AU-IS85CFHT	Ferrule 1/2"pour bo yau FH-H122H	Ferrule 1/2" for hose FH-H122H
19	4.00	AU-ISN1088HT	Raccord droit 1/2" mnpt x 1/2"hb pour FH-H12 et H122H	Straight fitt. 1/2" mnpt x 1/2"hb for FH-H12and H122H Hose
20	14.00	FH-H122H	Boyau 1/2" x 2plis, noir 4000 lbs/po2, 275oF	1/2" x 2ply, blac k 4000 psi, 275oF
21	1.00	JB-9303CH M4C	Po mpe cent. h yd. 1 1/2" x 1 1/4", 110gp m, 90 lb/po2	Cent. pu mp, 1 1/2" x 1 1/4", 110gp m, 90 psi
22	2.00	MO-80104	Qc à bille fer mé hyd. mâle 1/2" x 1/2"fnpt pl***	Close ball coupler mâle 1/2" x 1/2"fnpt pl***
23	1.00	AU-DECH YDCOCF	Autocollant config. circuit h ydr. ouvert ou fer mé	Decal config,h ydr.circuit open or close center
24	1.00	AU-243A	Vanne de drain 1/8" mnpt laiton	Drain valve 1/8" mnpt brass

Desc. Française **Ens. de pompe 9403540 avec filtre 1 1/2" pulv. porté**
 English Desc. **Cent pump, 1 1/2" suc 1 1/2" exit 3 points hitch**

Réf.	Quantité	Produit	Description française	English Description
1	1.00	JB-LL112NY	Adapt. coudé 1 1/2"fnpt x 1 1/2"fnpt céd.80 ny	Elbow adapt. 1 1/2"fnpt x 1 1/2"fnpt ced.80 ny
2	1.00	JB- M1120NY	Mamelon court 1 1/2" mnpt x 1 1/2" mnpt céd.80 ny	Close nipple 1 1/2" mnpt x 1 1/2" mnpt ced.80 ny
3	1.00	MP-S301500PP	Valve à bille 2v 1 1/2"fnpt ny, joint EPDM	Ball valve 2v 1 1/2"fnpt ny, EPDM seal
4	1.00	JB- IMB1212NY	Adapt. droit 1 1/2" mnpt x 1 1/2"hb céd.80 ny	Straight adapt. 1 1/2" mnpt x 1 1/2"hb ced.80 ny
5	1.00	MP-G40004	Gas ket 1"	1" gas ket
6	3.00	LV-112PVC	Boyou vert renf., 1 1/2", 70 lb/po2, succion	Suction hose 1 1/2", green
7	1.00	MS-GPDFPC	Garde p.d.f. pompe centrifuge	Centrifugal pump p.t.o. guard
8	1.00	JB-9403C540S	Pompe cent. courroie 98gpm, 540rpm, 60lb/po2, 1"	Cent. pump-belt drive, 98gpm, 540rpm, 60psi, 1"
9	1.00	JB-EL114112N Y40	Adapt. coudé 1 1/4" mnpt x 1 1/2"hb céd.40 ny	Elbow adapt. 1 1/4" mnpt x 1 1/2"hb ced.40 ny
9	1.00	JB-EL1141NY	Adapt. coudé 1 1/4" mnpt x 1"hb céd.80 ny	Elbow adapt. 1 1/4" mnpt x 1"hb ced.80 ny
10	2.00	DA-HS24	Collet 1 1/16" x 2"	Collar 1 1/16" x 2"
11	1.00	MP-2200601	Adapt. droit 1 1/2" mnpt céd.40 ny	Straight adapt. 1 1/2" mnpt ced.40 ny
12	1.00	MP-210060	Capuchon 1 1/2"fnpt céd.40 ny	Plug 1 1/2"fnpt ced.40 ny
13	2.00	DA- MH4	Collier de serrage 7/32" x 5/8"	Collar 7/32" x 5/8"
14	8.00	LV-142N	Boyou noir, 1/4", 200 lb/po2, 2 plis	Black hose, 1/4", 200 psi, 2 ply
15	1.00	JB-E MB0102BR	Adapt. coudé 1/8" mnpt x 1/4"hb céd.40 br	Elbow adapt. 1/8" mnpt x 1/4"hb ced.40 br
16	1.00	JB-E MB0102BR	Adapt. coudé 1/8" mnpt x 1/4"hb céd.40 br	Elbow adapt. 1/8" mnpt x 1/4"hb ced.40 br
17	1.00	CA-P TO01	Arbre pdf 26 1/2", 1 3/8" 6 cannelures x 1" série 20	Pto shaft 26 1/2", 1 3/8" 6sp x 1" series 20
19	1.00	MS-SPR6	Support de pompe 9403	9403 pump support
20	1.00	JB- IMB1212NY	Adapt. droit 1 1/2" mnpt x 1 1/2"hb céd.80 ny	Straight adapt. 1 1/2" mnpt x 1 1/2"hb ced.80 ny
24	1.00	AU-243A	Vanne de drain 1/8" mnpt laiton	Drain valve 1/8" mnpt brass

Ajustement accumulateur sur pompe.		
Pression travail	Contrôle	Pression acc.
0 - 100 lbs/po ²	CE100	30 lbs/po ²
0 - 290 lbs/po ²	CE290	75 lbs/po ²

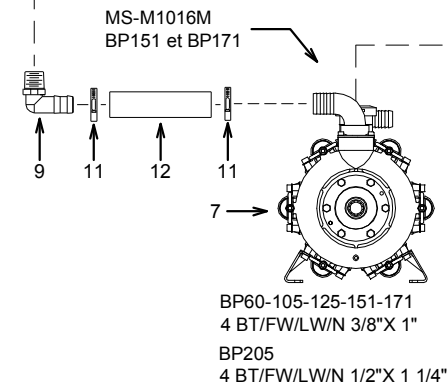
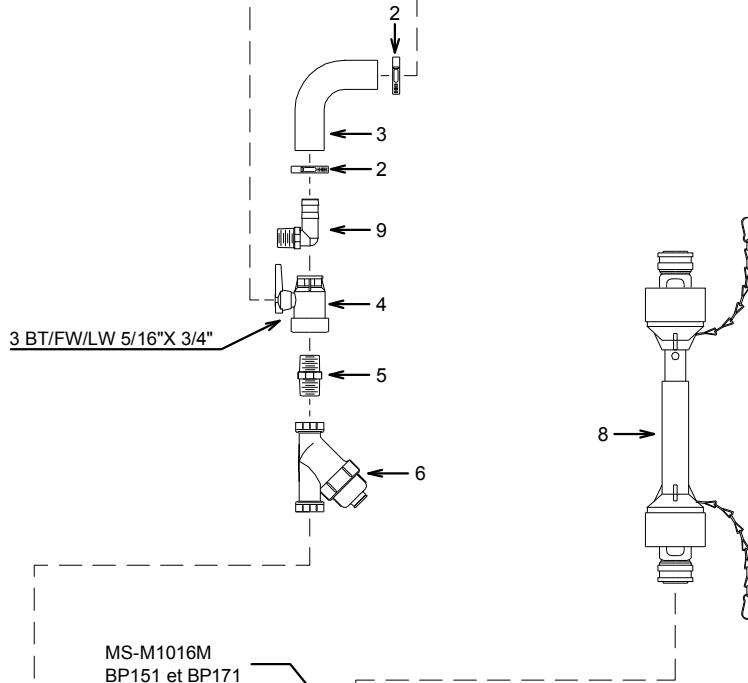
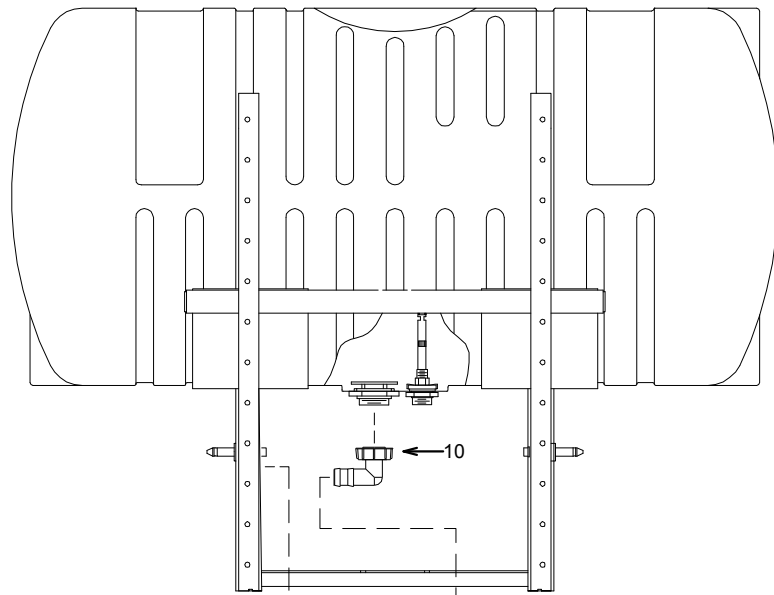

MS PULVÉRISATEUR MS Inc.		
PULVAGIPORTEPOMPEPBR1		
DATE: 2003-05-14	PAR: P.B.	
REV: 2004-05-05	PAR: E.L.	#REV: 0
TITRE: Pompe BP, pulv. porté, aspiration 1 1/2"		
# REC.: RE-PBP60R1	RE-PBP151R1	RE-PBP305R1
RE-PBP105R1	RE-PBP171R1	
RE-PBP125R1	RE-PBP205R1	APP:



MS Gregson Inc.

4300 rue Vachon, Drummondville QC J2B 6V4, Canada
Tél.: 819 474-1910 • Fax : 819 474-5317 • orders@msgregson.com

BOM

RE-PBP125R1

REVISION

0

Desc. Française Pompe BP125, pulv. porté asp. 1 1/2" filtre 1 1/2"

English Desc. P125 PUMP, 1 1/2" SUC 1 1/2" FIL TER

Réf.	Quantité	Produit	Description française	English Description
1	1.00	JB-IMB1212NY	Adapt. droit 1 1/2"mnpt x 1 1/2"hb céd.80 ny	Straight adapt. 1 1/2"mnpt x 1 1/2"hb ced.80 ny
2	2.00	DA-HS24	Collet 1 1/16" x 2"	Collar 1 1/16" x 2"
3	2.00	LV-112PVC	Boyau vert renf., 1 1/2", 70 lb/po2, suction	Suction hose 1 1/2", green
4	1.00	MP-S301500PP	Valve à bille 2v 1 1/2"fnpt ny, joint EPDM	Ball valve 2v 1 1/2"fnpt ny, EPDM seal
5	1.00	JB-M1120NY	Mamelon court 1 1/2"mnpt x 1 1/2"mnpt céd.80 ny	Close nipple 1 1/2"mnpt x 1 1/2"mnpt ced.80 ny
6	1.00	BJ-LS15050	Filtreur en Y, 1 1/2", 50 mailles	Y type filter, 1 1/2", 50 mesh
7	1.00	CO-BP125/20	Pompe à membrane 121 l/min 290 lbs/po2, 1 3/8 6cannelures	Diaphragm pump 32 gpm 290 psi, 1 3/8"6sp
8	1.00	CA-PTO03	Arbre pdf 26 1/2", 1 3/8" x 1 3/8" 6cannelures, série 20	Pto shaft 26 1/2", 2 x 1 3/8" 6sp,series 20
9	1.00	JB-EL112NY40	Adapt. coudé 1 1/2"mnpt x 1 1/2"hb céd.40 ny	Elbow adapt. 1 1/2"mnpt x 1 1/2"hb ced.40 ny
10	1.00	MP-1166401	Adapt. coudé 1 1/2"pfbsp x 1 1/2"hb céd.40 ny	Elbow adapt. 1 1/2"hb x 1 1/2"fnpt ced.40 ny
11	2.00	DA-HS24	Collet 1 1/16" x 2"	Collar 1 1/16" x 2"
12	2.00	LV-112PVC	Boyau vert renf., 1 1/2", 70 lb/po2, suction	Suction hose 1 1/2", green



MS Gregson Inc.

4300 rue Vachon, Drummondville QC J2B 6V4, Canada
Tél.: 819 474-1910 • Fax : 819 474-5317 • orders@msgregson.com

BOM

RE-PBP171R1

REVISION



0

Desc. Française	Pompe BP171, pulv. porté asp. 1 1/2" filtre 1 1/2"
English Desc.	BP171 PUMP, 3 POINTS HITCH, 1 1/2" SUC FIL TER 1 1/2"

Réf.	Quantité	Produit	Description française	English Description
1	1.00	JB-IMB1212NY	Adapt. droit 1 1/2"mnpt x 1 1/2"hb céd.80 ny	Straight adapt. 1 1/2"mnpt x 1 1/2"hb ced.80 ny
2	2.00	DA-HS24	Collet 1 1/16" x 2"	Collar 1 1/16" x 2"
3	2.00	LV-112PVC	Boyau vert renf., 1 1/2", 70 lb/po2, suction	Suction hose 1 1/2", green
4	1.00	MP-S301500PP	Valve à bille 2v 1 1/2"fnpt ny, joint EPDM	Ball valve 2v 1 1/2"fnpt ny, EPDM seal
5	1.00	JB-M1120NY	Mamelon court 1 1/2"mnpt x 1 1/2"mnpt céd.80 ny	Close nipple 1 1/2"mnpt x 1 1/2"mnpt ced.80 ny
6	1.00	BJ-LS15050	Filtreur en Y, 1 1/2", 50 mailles	Y type filter, 1 1/2", 50 mesh
7	1.00	CO-BP17120	Pompe à membrane 168 l/min 290 lb/po2, 1 3/8 6cannelures	Diaphragm pump 168 l/min 290 lb/po2, 1 3/8"
8	1.00	CA-PTO03	Arbre pdf 26 1/2", 1 3/8" x 1 3/8" 6cannelures, série 20	Pto shaft 26 1/2", 2 x 1 3/8" 6sp,series 20
9	1.00	JB-EL112NY40	Adapt. coudé 1 1/2"mnpt x 1 1/2"hb céd.40 ny	Elbow adapt. 1 1/2"mnpt x 1 1/2"hb ced.40 ny
10	1.00	MP-1166401	Adapt. coudé 1 1/2"pfbps x 1 1/2"hb céd.40 ny	Elbow adapt. 1 1/2"hb x 1 1/2"fnpt ced.40 ny
11	2.00	DA-HS24	Collet 1 1/16" x 2"	Collar 1 1/16" x 2"
12	2.00	LV-112PVC	Boyau vert renf., 1 1/2", 70 lb/po2, suction	Suction hose 1 1/2", green

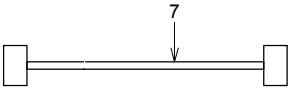
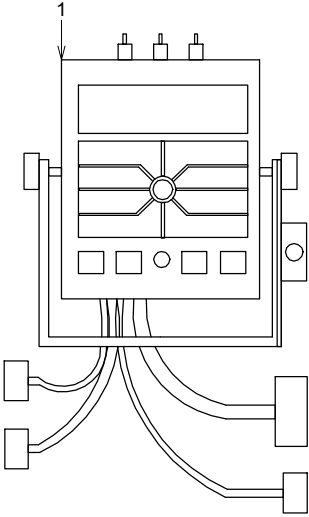
Contrôleur Spray Mate 3 sections
 3 sections Spray Mate controller



		PULVÉRISATEUR MS Inc.	
		MS SPRAYER Inc.	
\\PULVAG\CONTROLE MODULAIRE\SM			
DATE: 2002-12-02	PAR/ BY: G.L.		
REV: 2003-11-27	PAR/ BY: G.L.	#REV: 1	
# REC.: MS-SM		MS-SMT500	
MS-CAD4RS			
			APP: 

APPROUVÉ LE: 2007-01-18 09:31:30 PAR: LANDIEG





Description Française	Contrôleur spry mate 3 sections avec câble
English Description	3 sections spry mate controller with cable

<u>Ref.</u>	<u>Q</u>	<u>Prd</u>	<u>Ref.</u>	<u>Q</u>	<u>Prd</u>	<u>Ref.</u>	<u>Q</u>	<u>Prd</u>
1	1.00	MT-01341						
2	1.00	MT-14226						

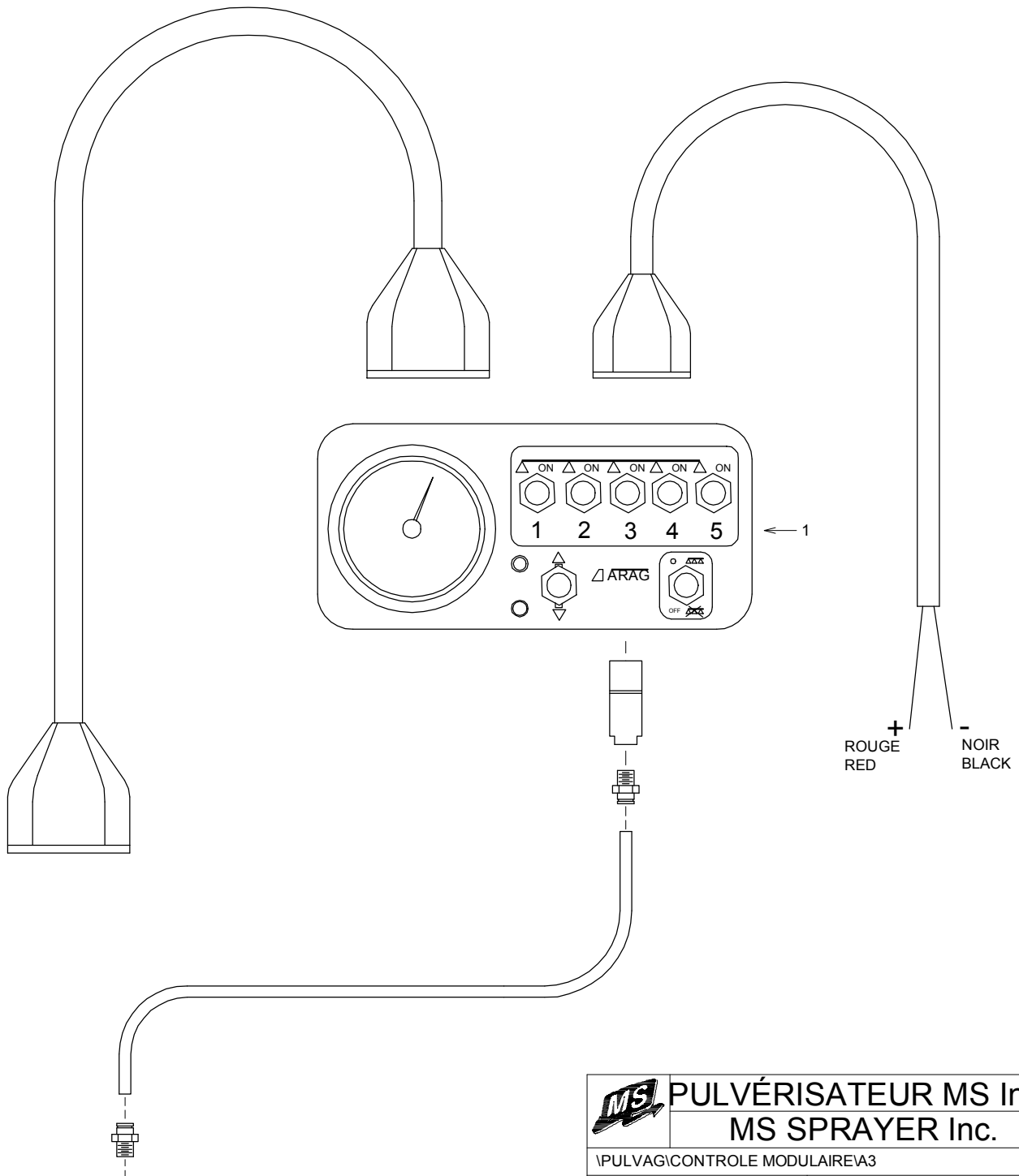
CONTRÔLE ARAG3 ET 5 SECTIONS AVEC CABLE
 3 AND 5 SECTIONS ARAG CONTROL WITH CABLE



prendre pression au contrôle

		PULVÉRISATEUR MS Inc.	
		MS SPRAYER Inc.	
PULVAG CONTROLE MODULAIREA3			
DATE: 2002-07-03	PAR/	BY: P.B.	
REV: 2003-09-22	PAR/	BY: E.L.	#REV:
# REC.: MS-A3			
MS-A5			
			APP: 

APPROUVÉ LE: 2007-03-02 13:42:39 PAR: LANDIEG



MS Gregson Inc.
4300 rue Vachon, Drummondville QC J2B 6V4, Canada
Tél.: 819 474-1910 • Fax : 819 474-5317 • orders@msgregson.com



BOM	MS-A3
REVISION	0

Desc. Française Contrôle arag 3 sections avec câble
English Desc. 3 sections arag control with cable

Réf.	Quantité	Produit	Description française	English Description
1	1.00	MP-4662530P300	Ens. console, cable, cadran arag 3sections	Console, cable, gage 3 sections arag kit
5	1.00	MP-466530230	Extension de 5 mètres pour cea3	Wiring harness for cea3

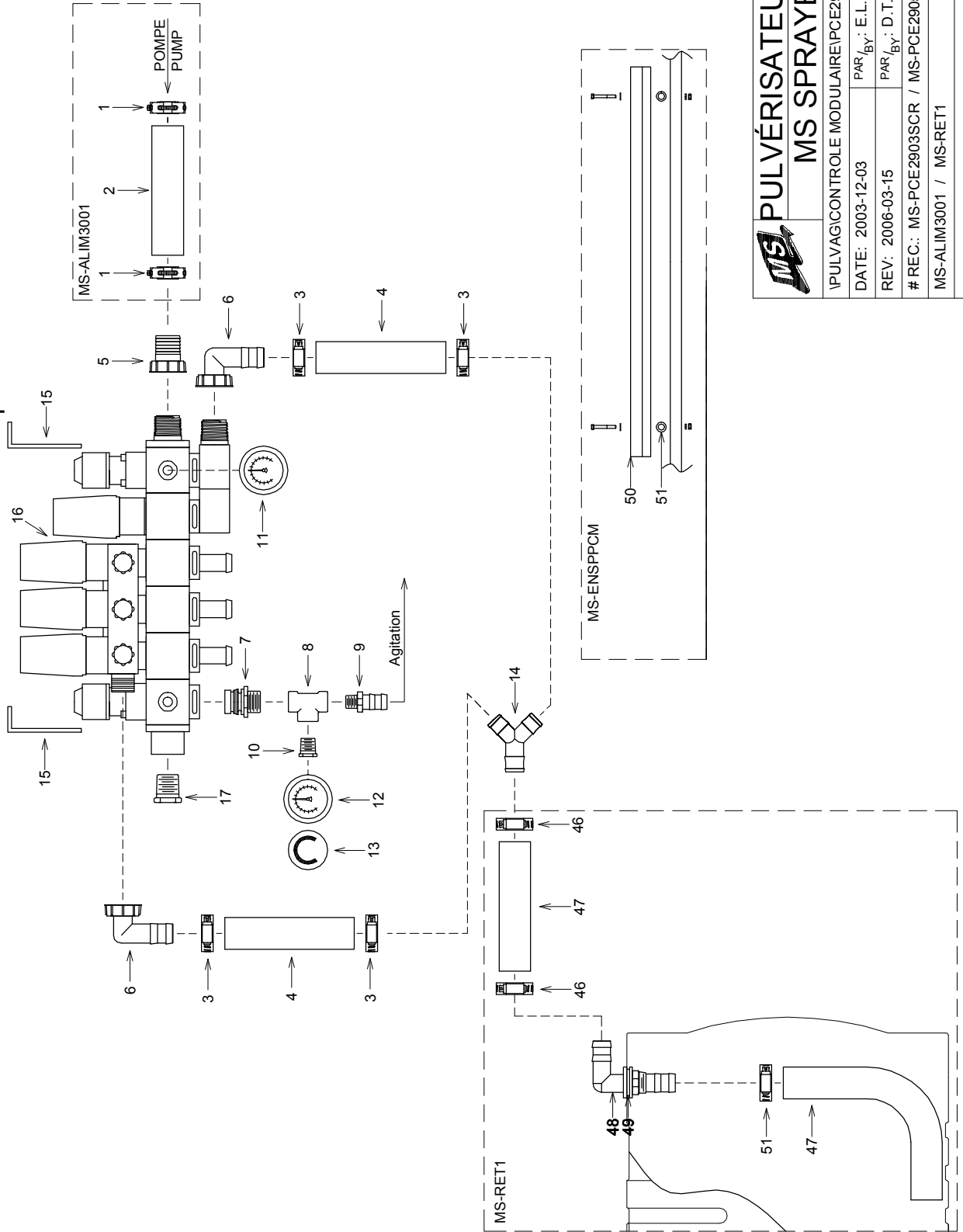
Contôle électrique 290 lb/po² cmcr
 Cmcrr elect. control 290 lb/po²



 PULVÉRISATEUR MS Inc. MS SPRAYER Inc.	PULVAG/CONTROLE MODULAIRE/PCE290CR	
	DATE: 2003-12-03	PAR/By: E.L.
	REV: 2006-03-15	PAR/By: D.T.
	#REV: 1	
	# REC.: MS-PCE2903SCR / MS-PCE2905SCR	
MS-ALIM3001 / MS-RET1		APP: 



MS Gregson Inc.

4300 rue Vachon, Drummondville QC J2B 6V4, Canada
Tél.: 819 474-1910 • Fax : 819 474-5317 • orders@msgregson.com

BOM

MS-PCE2903SCR

REVISION

0

Desc. Française Contrôle électrique 3 sect. 290 lb/po²
English Desc. Cmcrc elect. control 3 sect. 290 lb/po²

Réf.	Quantité	Produit	Description française	English Description
3	4.00	DA-SHAS16	Collier de serrage en acier inox. 11/16" x 1 1/2"	Stainless collar 11/16" x 1 1/2"
4	8.00	LV-12N	Boyau noir, 1", 150 lb/po ² , caoutchouc 2 plis uni	Black hose, 1", 150 psi, rubber smooth 2 pli
5	1.00	MP-1064251	Adapt. droit 1"pfbsp x 1"hb céd.40 ny	Straight adapt. 1"fnpt x 1"hb ced.40 ny
6	2.00	MP-1164251	Adapt. coudé 1"pfbsp x 1"hb céd.40 ny	Elbow adapt. 1"fnpt x 1"hb ced.40 ny
7	1.00	MP-463001220M	Adapt. brass vissé trou 1/2" ID 0.550"	Threaded brass adapt.1/2"hole
8	1.00	JB-TT12NY	Adapt. en t 1/2"fnpt x 1/2"fnpt x 1/2"fnpt céd.80 ny	T adapt. 1/2"fnpt x 1/2"fnpt x 1/2"fnpt ced.80 ny.
9	1.00	JB-IMB0406NY	Adapt. droit 1/2"mnpt x 3/4"hb céd.80 ny.	Straight adapt. 1/2"mnpt x 3/4"hb ced.80 ny.
10	1.00	JB-RB1214NY40	Réduit 1/2"mnpt x 1/4"fnpt céd.40 ny	Reducer 1/2"mnpt x 1/4"fnpt ced.40 ny
11	1.00	JB-025FFBC00400	Cadran mont. arr. 1/4"mnpt 0 à 400 lb/po ² x2 1/2"l br	Back mount gage 1/4"mnpt 0 to 400 psi x2 1/2"l br
12	1.00	JB-025FFBC00100	Cadran mont. arr. 1/4"mnpt 0 à 100 lb/po ² x2 1/2"l br	Back mount gage 1/4"mnpt 0 to 100 psi x2 1/2"l br
13	1.00	AU-DECAGIT	Autocollant agitation	Decal agitation
14	1.00	MP-140002	Adapt. en y 1"hb	Y adapt. 1"hb
15	2.00	MS-463473D	Attache electro-valve 463-473 décentré	Off-center 463-473 electro-valve bracket
16	1.00	MP-4634131S	Ens. 3 sect. 0.6 sec., régulateur, valve +/-, valve agit.	Elect.contr.3 valves 0.6sec.300 psi w/regulator
17	1.00	JB-VMM0008NY	Bouchon 1"mnpt céd.80 ny	Plug 1"mnpt ced.80 ny



MS Gregson Inc.

4300 rue Vachon, Drummondville QC J2B 6V4, Canada
Tél.: 819 474-1910 • Fax : 819 474-5317 • orders@msgregson.com

BOM	MS-ALIM3001
REVISION	0

Desc. Française Ens. d'alim. bo yau 1", 300 lb/po²
 English Desc. 1" suppl y line 300 psi kit

Réf.	Quantité	Produit	Description française	English Description
1	2.00	AS-3740	Collier de serrage mikalor / boyau 1"	Mikalor collar / 1" hose
2	10.00	LV-12N300	Boyau noir, 1", 300 lb/po ² , 2 plis	Black hose 1", 2 ply, 300 psi



MS Gregson Inc.
 4300 rue Vachon, Drummondville QC J2B 6V4, Canada
 Tél.: 819 474-1910 • Fax : 819 474-5317 • orders@msgregson.com

BOM	MS-ENSPPCM
REVISION	0

Desc. Française Ens. de plaque de protection pour contrôle modulaire
 English Desc. Protector kit for modular control

Réf.	Quantité	Produit	Description française	English Description
50	1.00	MS-PPVSR2	Plaque protectrice valve	Valves protective guard
51	2.00	MS-IBSPJB	Espaceur interface premelangeur	Inductor interface spacer

Ens. de 3 valves solen. 144 avec lect. GFN750 3 144 selen. kit with magn. GFN750 flow meter

#22 Lecteur de débit électro-magnétique
#22 Electro-magnetic flow meter
A Jaune-vert / Yellow-green
B Brun / Brown
C Bleu / Blue

#22 Lecteur de débit à turbine
#22 Turbine flow meter
A Vert / Green
B Brun / Brown
C Blanc / White

Lecteur de débit (attache verte)
Flow meter (green tie)

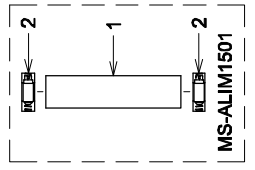
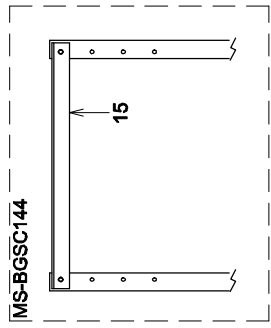
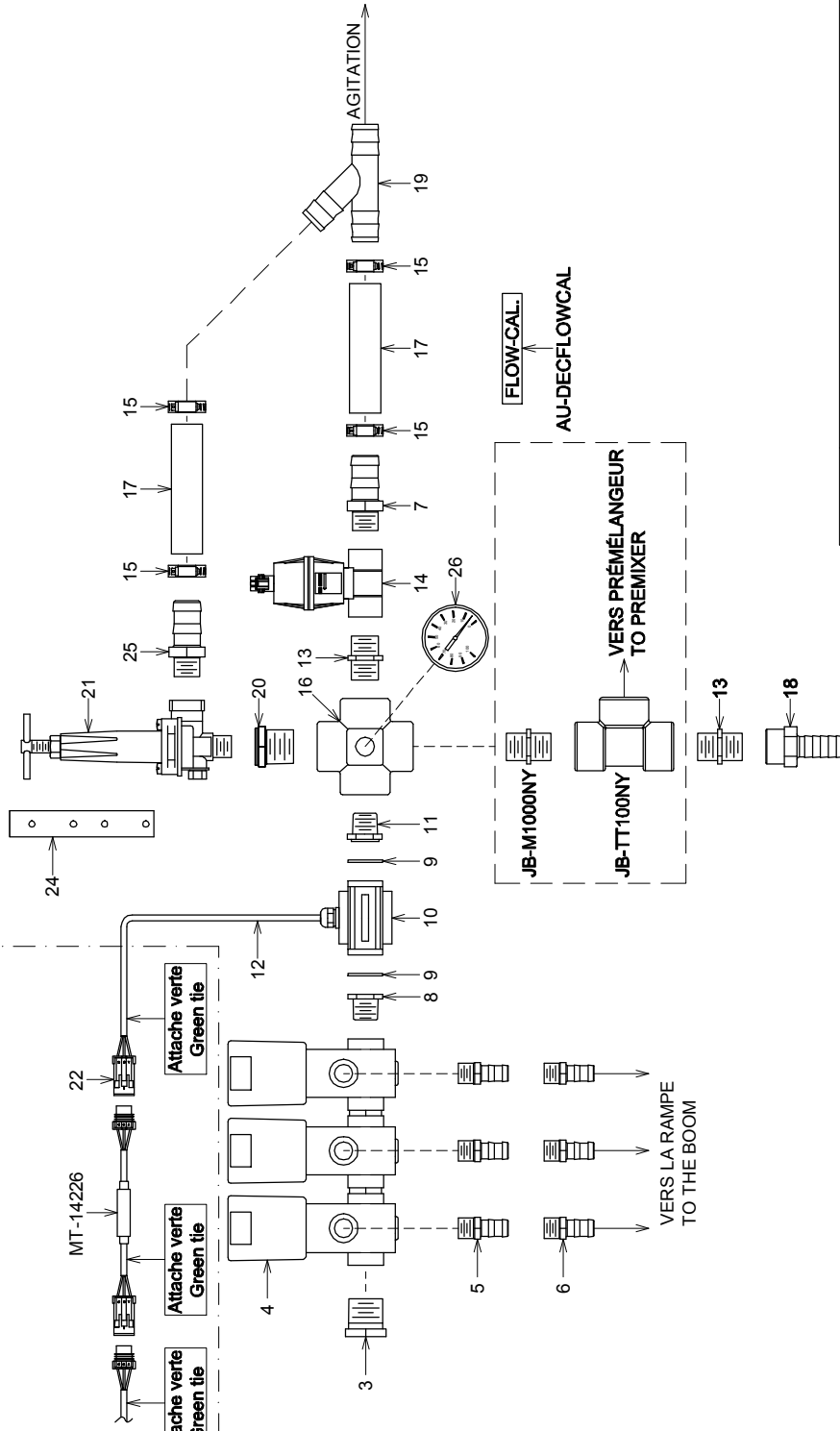

PULVÉRISATEUR MS Inc. MS SPRAYER Inc.	
PULVAGICONTROLE MODULAIREA6	
DATE: 2003-11-27	PAR / BY: G.L.
REV: 2007-09-06	PAR / BY: D.T.
# REC.: MS-A6	#REV: 1
MS-ALIM1501	
APP:	



Description Française Ens. de 3 valves solen., lect. turbine pompe membrane
 English Description 3 144 selen. kit with magn. gfn750 flo w meter

<u>Ref.</u>	<u>Q</u>	<u>Prd</u>	<u>Ref.</u>	<u>Q</u>	<u>Prd</u>	<u>Ref.</u>	<u>Q</u>	<u>Prd</u>
3	1.00	JB-VMM0006NY						
4	1.00	JB-AA144P3						
5	3.00	JB-IMB0406BR						
6	3.00	JB-IMB0404BR						
7	1.00	JB-IMB0808NY						
8	1.00	MP-463000130						
9	2.00	MP-G10071V						
10	1.00	MP-46264A0						
11	1.00	MP-463000040						
12	1.00	MS-4623711010						
13	2.00	JB-M1000NY40						
14	1.00	MT-19093						
15	4.00	DA-SHAS16						
16	1.00	MS-CR10014NPT						
17	4.00	LV-12N						
18	1.00	MP-1064251						
19	1.00	MP-140002						
20	1.00	JB-RB10034NY						
21	1.00	MS-846034300						
24	1.00	MS-RAASBHD						
25	1.00	JB-IMB0608BR						
26	1.00	JB-025FFBC00160						

Ens. de 3 valves solen. 144 avec lect. GFN750
3 144 selen. kit with magn. GFN750 flow meter

#22 Lecteur de débit électro-magnétique
 #22 Electro-magnetic flow meter
 A Jaune-vert / Yellow-green
 B Brun / Brown
 C Bleu / Blue

Lecteur de débit (attache verte)
 Flow meter (green tie)

#22 Lecteur de débit à turbine
 #22 Turbine flow meter
 A Vert / Green
 B Brun / Brown
 C Blanc / White

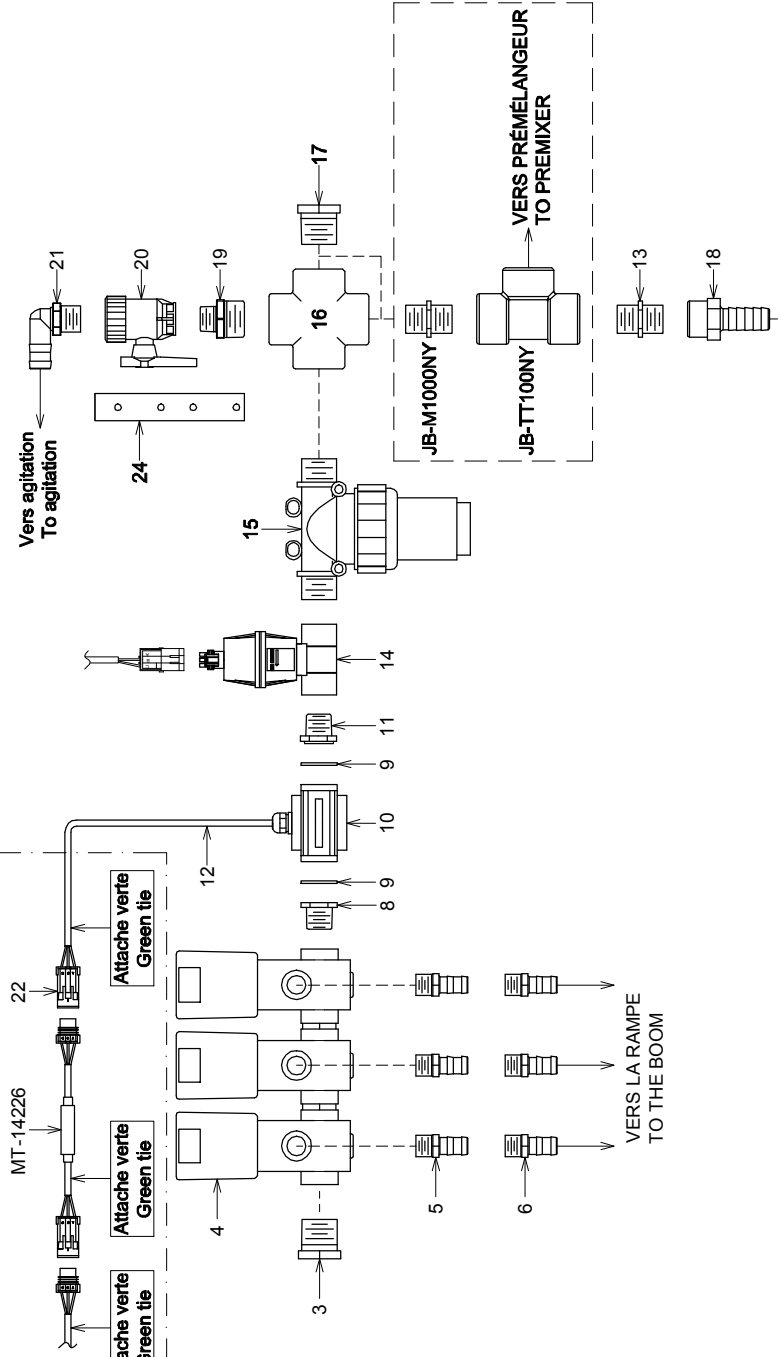

MS		PULVÉRISATEUR MS Inc.	
		MS SPRAYER Inc.	
IPULVAG/CONTROLE MODULAIREA6C			
DATE: 2002-11-20	PAR / By: P. B.		
REV: 2007-09-06	PAR / By: D. T.	#REV: 1	
# REC.: MS-A6C		MS-F1 / MS-ALIM1501	
			APP: <i>[Signature]</i>

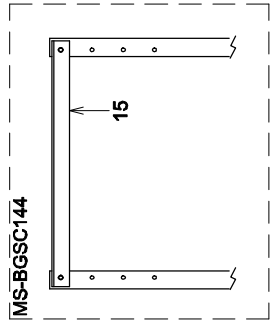
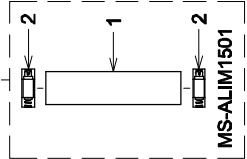

Desc. Française Ens. de 3 valves solen., lect. turbine pompe centrifuge
 English Desc. 3 144 selen. kit with turbin flo w meter

Réf.	Quantité	Produit	Description française	English Description
3	1.00	JB-VMM0006NY	Bouchon 3/4"mnpt céd.80 ny	Plug 3/4"mnpt ced.80 ny
4	1.00	JB-AA144P3	Valve (3) solénoïde 2v 3/4"fnpt 100 lb/po2 12vcc	Solenoid valve (3) 2v 3/4"fnpt 100 psi 12vdc
5	3.00	JB-IMB0406BR	Adapt. droit 1/2"mnpt x 3/4"hb céd.40 br.	Straight adapt. 1/2" x 3/4"hb ced.40 br.
6	3.00	JB-IMB0404BR	Adapt. droit 1/2"mnpt x 1/2"hb céd.40 br.	Straight adapt. 1/2"mnpt x 1/2"hb ced.40 br.
8	1.00	MP-463000130	Adapt. flange femelle x 3/4"mBSP ny.	Adapt. 3/4"mbsp ny.
9	2.00	MP-G10071V	Joint torique de valve série 463***	O-ring viton***
10	1.00	MP-46264A0	Lecteur de débit à palette 10 à 200 l/min, 725 psi	ARAG paddle flow meter, 2.6 to 52 gpm ,725psi
11	1.00	MP-463000040	Adapt. flange male x 1"bsp male ny	Theaded adapt. male flange x 1"bsp male ny
12	1.00	MS-4623711010	Câble de lecteur de débit électro-magnétique assemblé	Cable for electro-magnetic flometer assembly
13	1.00	JB-M1000NY40	Mamelon court 1"mnpt x 1"mnpt céd.40 ny	Close nipple 1"mnpt x 1"mnpt ced.40 ny
14	1.00	MT-19093	Servo valve 1" 150 lb/po2 / fil*** 6/12 vcc	Servo valve 1" 150psi / wire*** 6/12 vdc
15	1.00	AU-8110009	Filtreur 1" mbsp x 1" mbsp, 290 lbs/po2, 50 mailles	Strainer 1" mbsp x 1" mbsp, 290 psi, 50 mesh
16	1.00	BJ-CR100	Croix 1"fnpt céd.80 ny	Cross 1"fnpt ced.80 ny
17	1.00	JB-VMM0008NY	Bouchon 1"mnpt céd.80 ny	Plug 1"mnpt ced.80 ny
18	1.00	MP-1064251	Adapt. droit 1"pfbps x 1"hb céd.40 ny	Straight adapt. 1"fnpt x 1"hb ced.40 ny
19	1.00	BJ-RN100075	Mamelon réducteur 1"mnpt x 3/4"mnpt céd.80 ny	Nipple red. 1"mnpt x 3/4"mnpt ced.80 ny
20	1.00	MP-S301250PP	Valve à bille 2v 3/4"fnpt ny, joint EPDM	Ball valve 2v 3/4"fnpt ny, EPDM seal
21	1.00	JB-EL3434NY	Adapt. coudé 3/4"mnpt x 3/4"hb céd.80 ny	Elbow adapt. 3/4"mnpt x 3/4"hb ced.80 ny
22	1.00	MT-13232F	Ens.connecteur femelle 3 pins m/p	Connector female kit 3 pins m/p
24	1.00	MS-RAASBHD	Sup, boyau hyd. double raa	Air assisted boom double hyd. hose brace



MS Gregson Inc.
 4300 rue Vachon, Drummondville QC J2B 6V4, Canada
 Tél.: 819 474-1910 • Fax : 819 474-5317 • orders@msgregson.com

BOM	MS-ALIM1501
REVISION	0

Description Française	Ens. d'alim. bo yau 1", 150 lb/po²
English Description	1" suppl y line 150 psi kit

<u>Ref.</u>	<u>Q</u>	<u>Prd</u>	<u>Ref.</u>	<u>Q</u>	<u>Prd</u>	<u>Ref.</u>	<u>Q</u>	<u>Prd</u>
1	10.00	LV-12N						
2	2.00	DA-SHAS16						

#	Ref.	Q.	"
12	LV-12N300	1	(101")

#	Ref.	Q.
1	LV-12N300	1
2	MS-1R1	1
3	MS-473SVR...	1
4	MS-473463LD...SST	1
5	JB-VMM0008NY	2
6	MS-ENSPPCMR1	1
7	MS-CAD4RR1	1
8	MS-RET114R1	1
9	AS-3740	2
10	AU-DECPRPULV	1
11	AU-DECCONT2	1

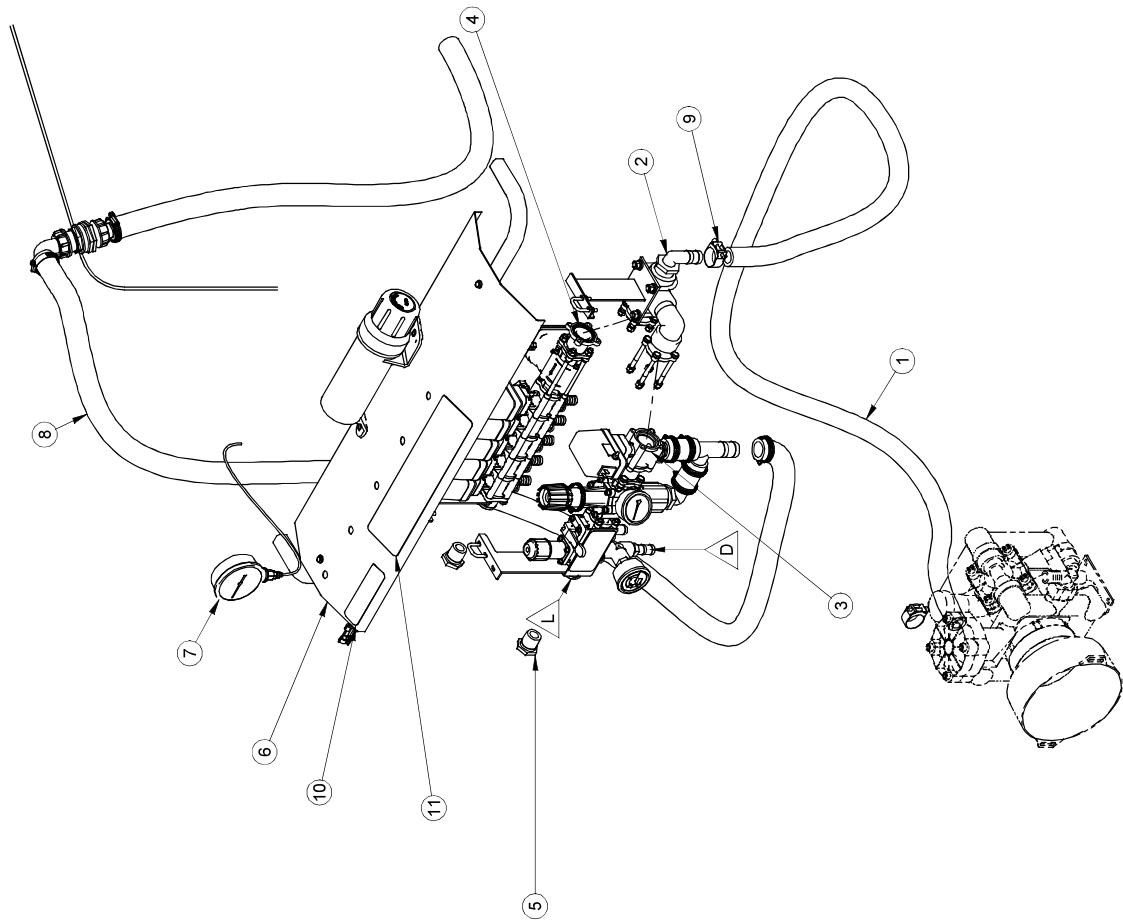

2007/02/08	MS-CMM_R1R3.asm	Pg:1-1
MS-CMMLDM5SAR1R3.dft	Rev. 0	Feuil1

#	Ref.	Q.
1	MS-IBSPJB	2
2	BT-142	2
3	BT-FW14	4
4	BT-LW14	2
5	BT-N14	2
6	AU-TUBEMAN	1
7	MS-PPVSR2	1
8	BT-102434RS	2
9	BT-FW316	4
10	BT-N1024	2

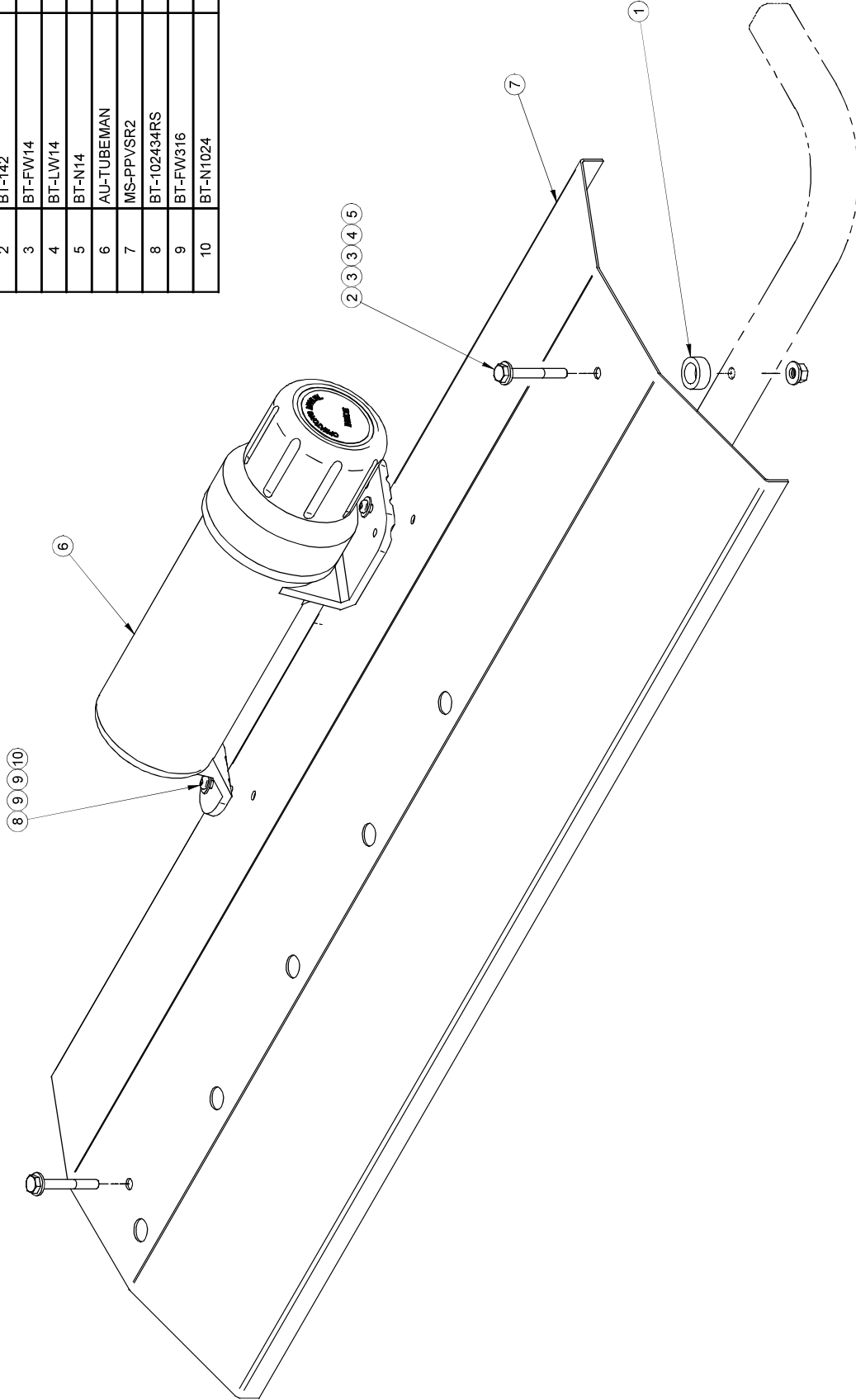

2007/01/05	MS-ENSPPCMR1.asm	Rev. 0	Pg:1-1
	MS-ENSPPCMR1.dft		Feuil1

#	Ref.	Q.	"
1	AU-33TNHN	1	360 "
2	AU-D70683A	1	
3	AU-119BA	1	
4	BT-FW916	2	
5	JB-025FF002004G	1	
6	MS-AMF080802NY	1	

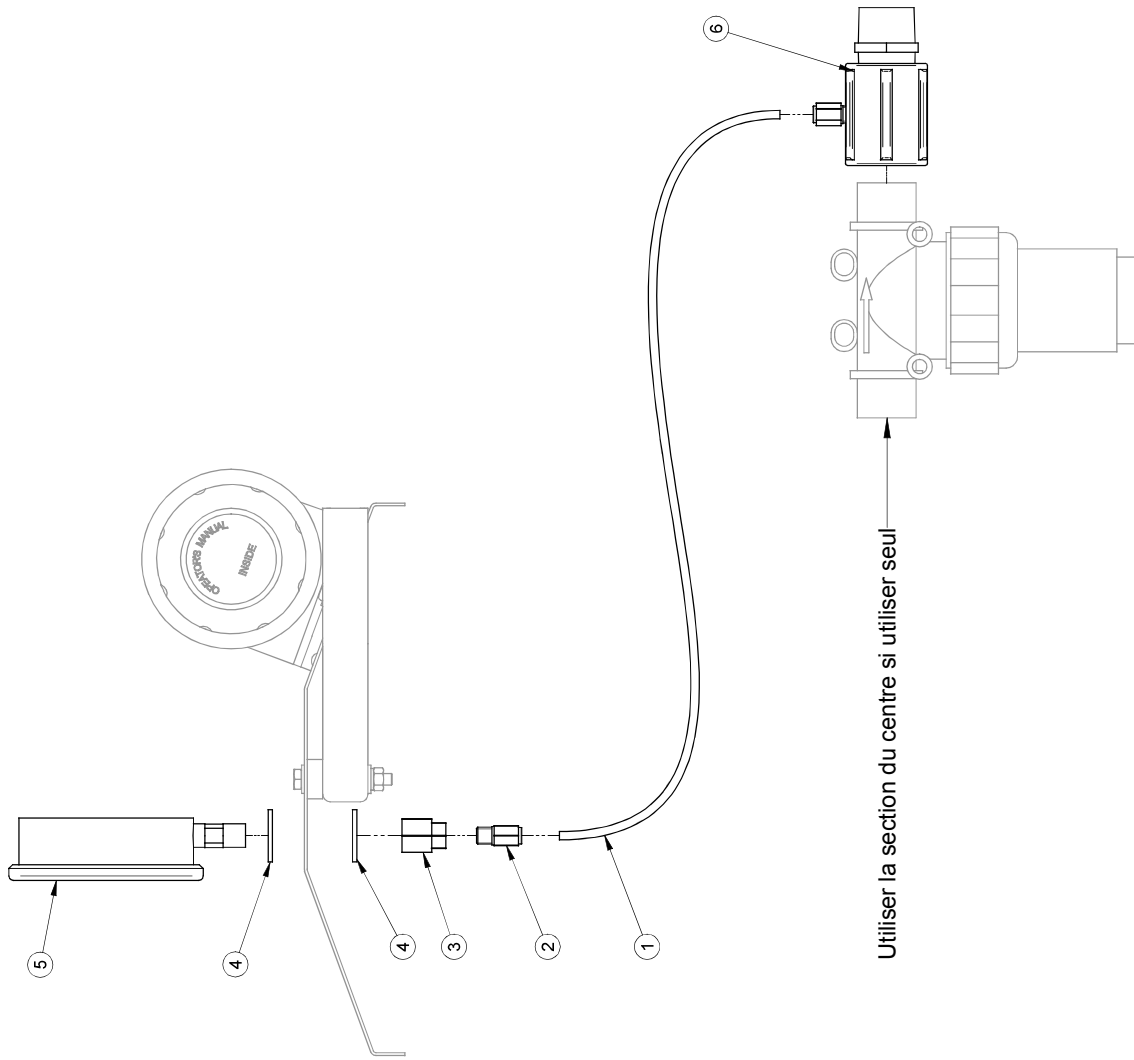
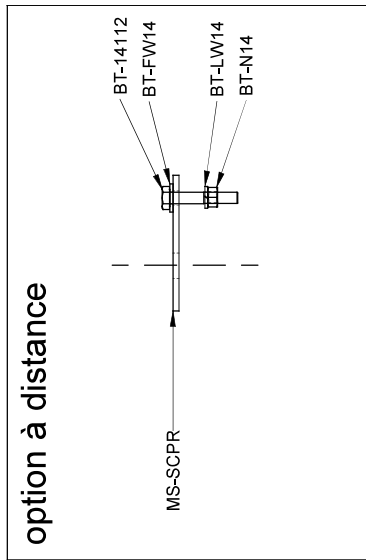

Utiliser la section du centre si utiliser seul

2008/10/07	MS-CAD4RSR2.asm	Rev. 0	Pg:1-1
	MS-CAD4RSR2.dft		Explose 1

#	Ref.	Q.	"
1	AU-33TNHN	1	360 "
2	MP-466350070	1	
3	AU-119BA	1	
4	BT-FW916	2	
5	JB-025FF003004G	1	
6	MS-AMF080802NY	1	

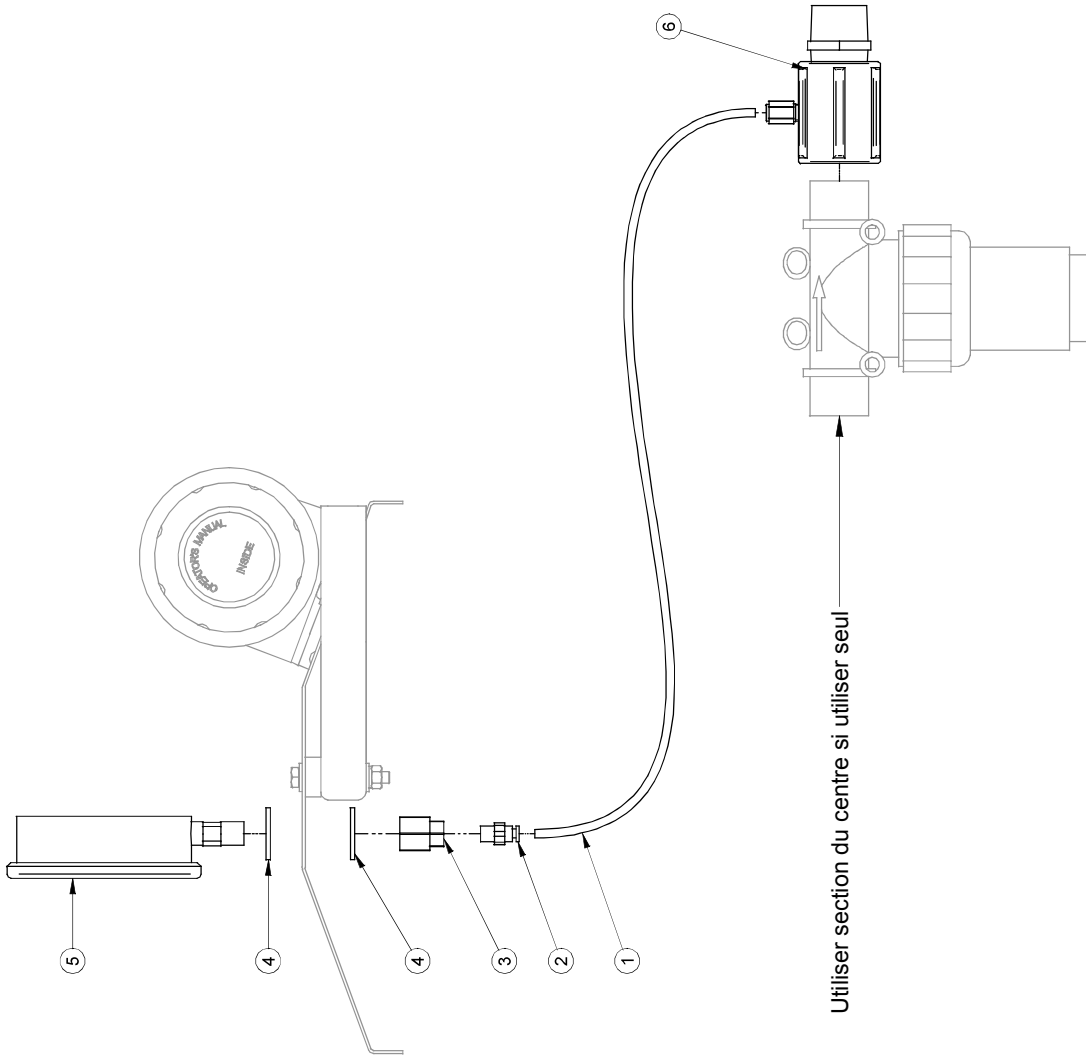
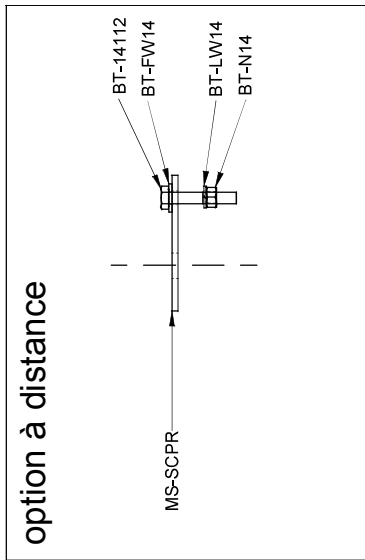

#	Ref.	Q.
1	JB-FC1000NY	1
2	MP-2502040	1
3	AU-D70683A	1

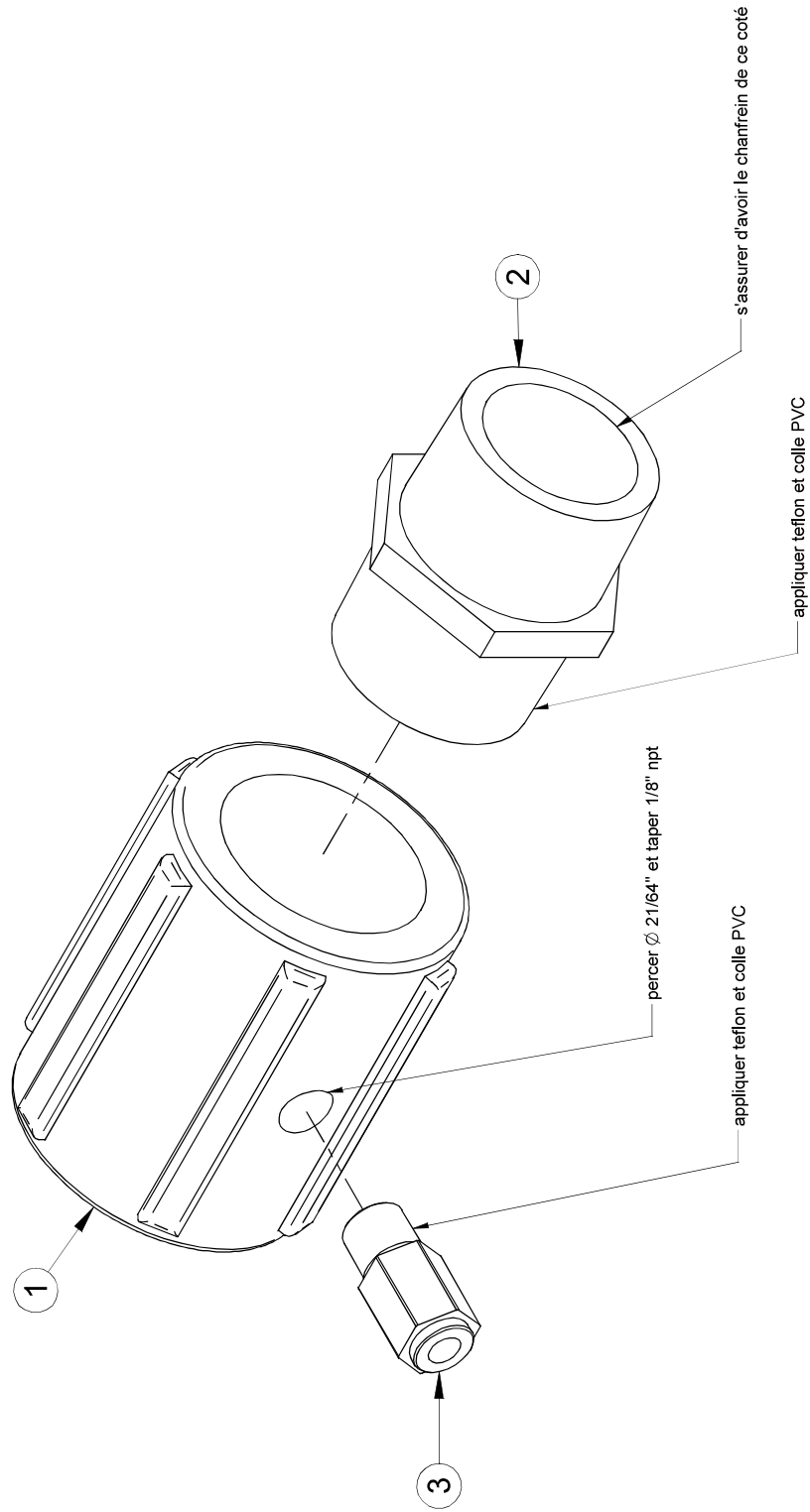

2007/08/02	MS-AMF080802NY.asm	Rev. 0	Pg:1-1
	MS-AMF080802NY.dft		Explose 1

#	Ref.	Q.
1	MP-473000051	2
2	JB-TT114NY	1
3	JB-SE114NY	1
4	MP-454236080V	2
5	JB-EL1141NY	1
6	SN-657802	16
7*	BT-M830SS	4
8	BT-LNM8	8
9	MS-463T	1
10	AU-UB141134	1
11	BT-FW14	2
12	BT-LN14	2
13	AU-UBR382143	2
14	BT-LW38	4
15	BT-N38	4
16	BT-FW38	4
17	BT-M890	4

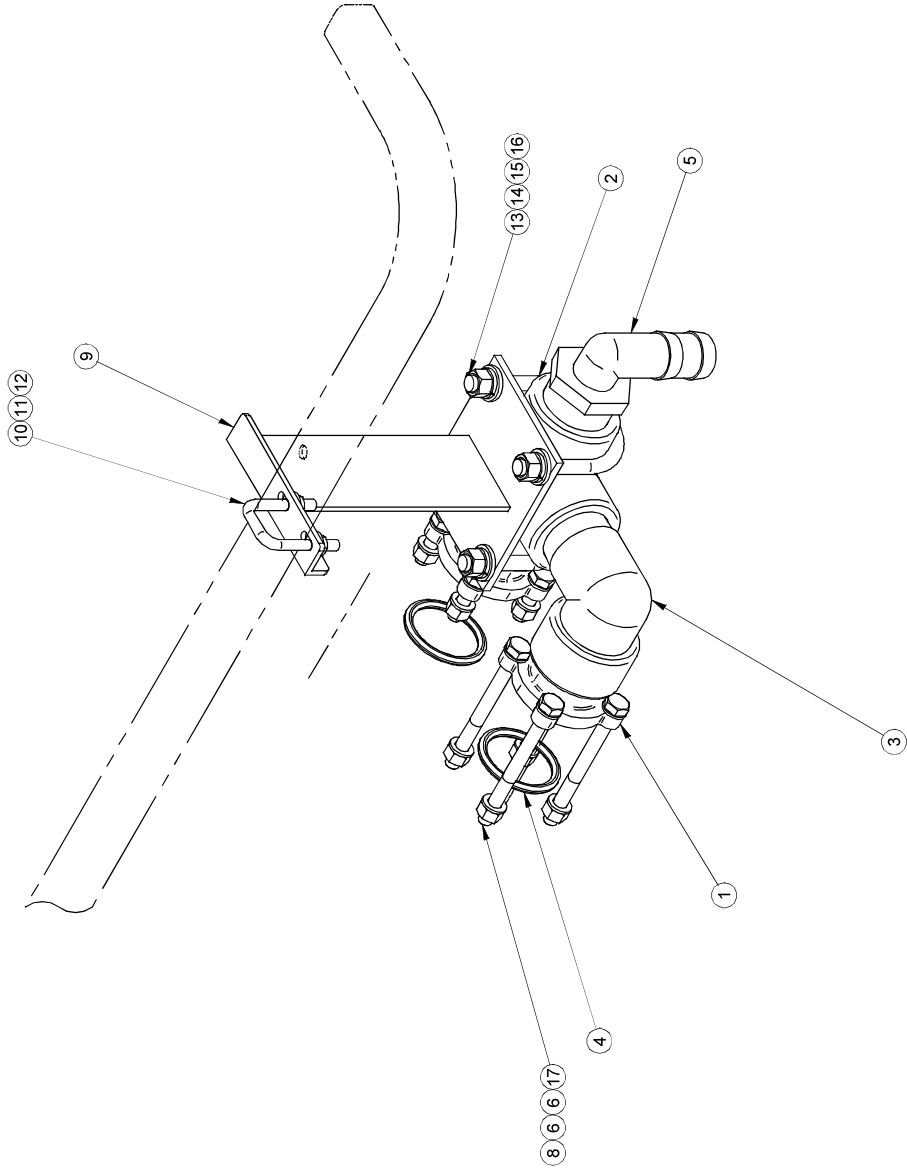

#	Ref.	Q.	"
1	LV-1142N	1	3"
2	LV-1142N	1	3"

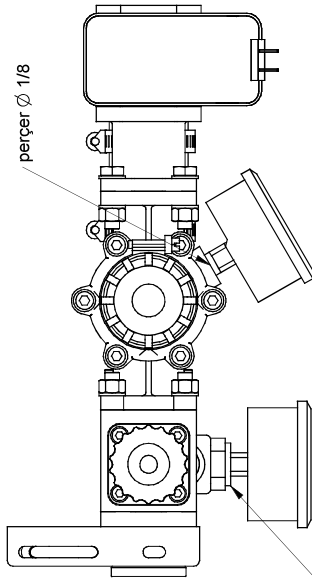

#	Ref.	Q.
35	BT-LN14	2
36*	AU-235002	1

#	Ref.	Q.
1	LV-1142N	1
2	LV-1142N	1
3	MP-473000110	1
5	MP-473020S	1
6	MP-465522	1
7	MP-463000143	1
8	MP-G10071V	3
9	SN-657802	14
10	MS-463473D	1
11	MP-454236080V	1
12	MP-463001220M	1
13	JB-025FFBC00400	1
14*	BT-M830	4
15	BT-LNIM8	8
16	BT-M890	4
19	MP-463070	1
22	AU-DECAGIT	1
23	JB-TT12NY	1
24	JB-IMB0406NY	1
25	JB-RB1214NY40	1
26	JB-T114NY40	1
27	JB-EL114NY	1
28	JB-025FFBC00100	1
29	JB-RB1141ny	1
30	JB-FC114NY	1
31	DA-HS24	4
33	AU-UB141134	1
34	BT-FW14	2

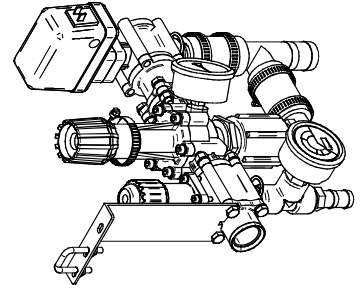
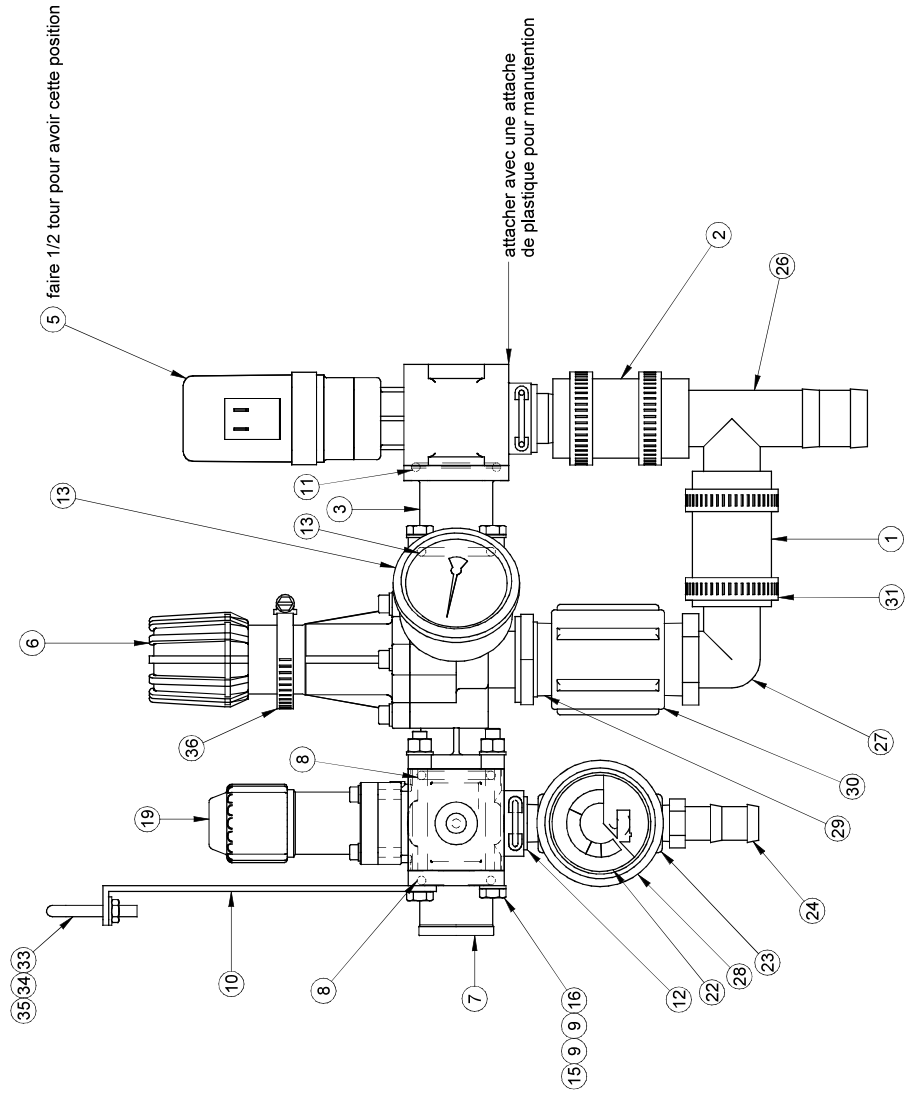

#	Ref.	Q.
1	MS-4623711010	1
2	MP-463900951	4
3	AU-UB141134	1
4	BT-FW14	2
5	BT-LN14	2
6	MS-463473D	1
7	MP-4630112ST	3
8	AU-DECFLOWCAL	1
9	MP-463000143	1
10	BT-LNM8	4
11	SN-657802	6
12	MP-G10071V	5
13	MP-46264A0	1
14	MP-473000110	1

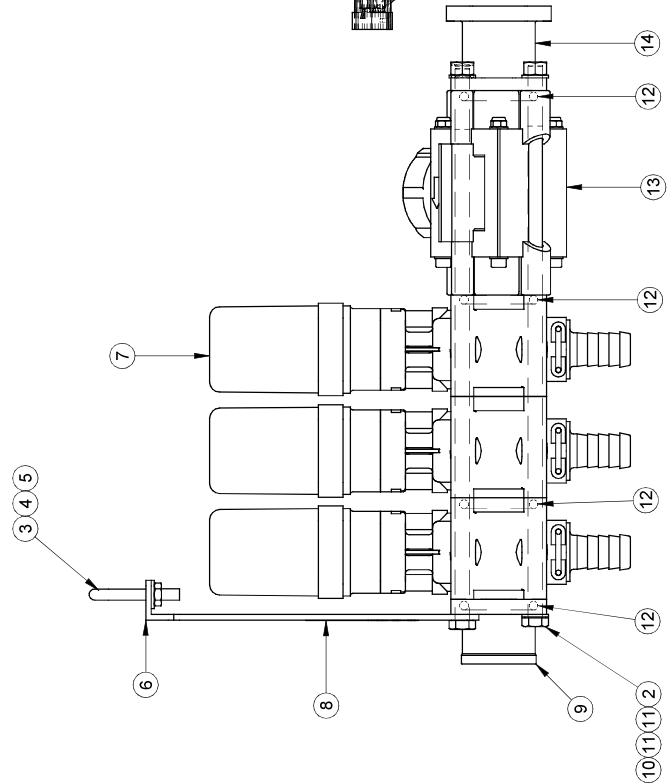
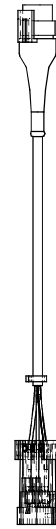
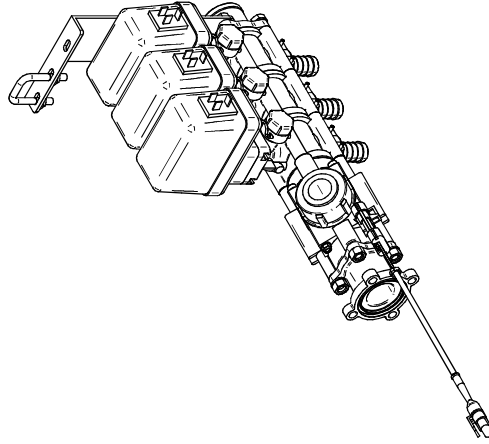
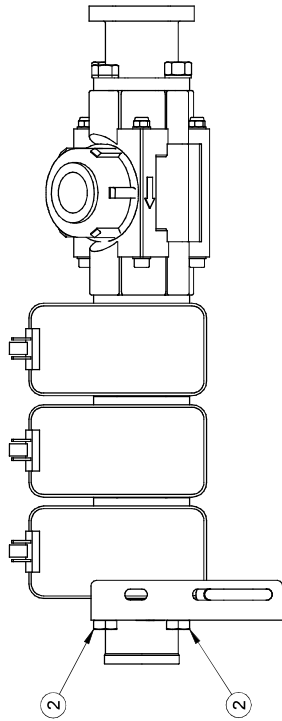
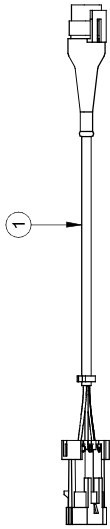

NOTES:
 1- LES VALEURS SONT EN POUCE SAUF SI SPÉCIFIÉ
 - VALUES ARE INCHES UNLESS SPECIFIED

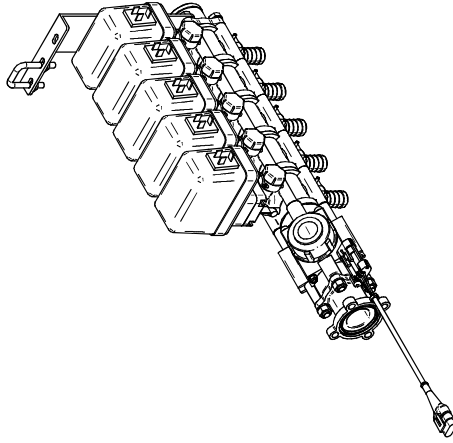
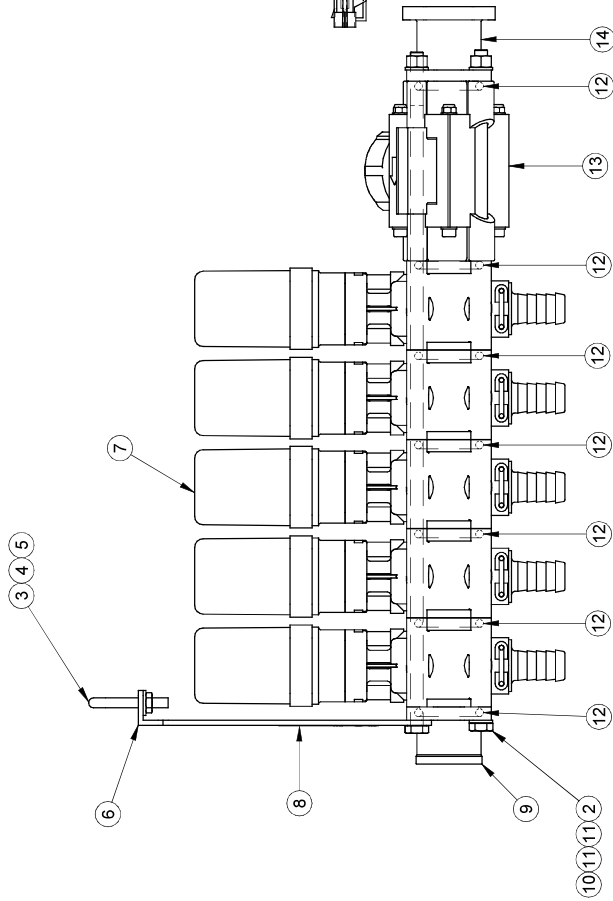
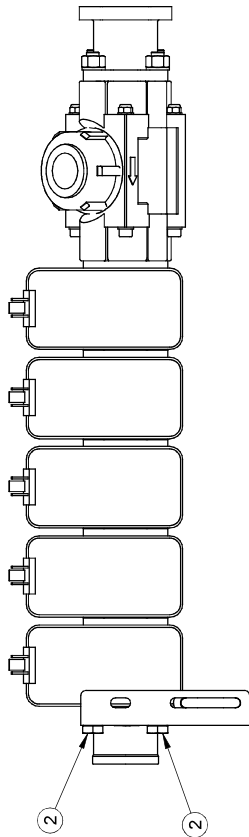
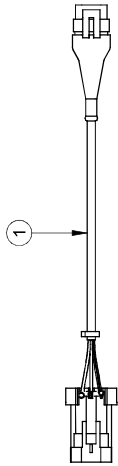

#	Ref.	Q.
1	MS-4623711010	1
2	MP-463900971	4
3	AU-UB141134	1
4	BT-FW14	2
5	BT-LN14	2
6	MS-463473D	1
7	MP-4630112ST	5
8	AU-DECFLOWCAL	1
9	MP-46300143	1
10	BT-LNM8	4
11	SN-657802	6
12	MP-G10071V	7
13	MP-46264A0	1
14	MP-473000110	1

REVISION ECO # -	DESCRIPTION DE LA RÉVISION / REVISION DESCRIPTION Eriever MT-13232F	# FEUILLE / SHEET # MS-473463LDT5SST	DATE CREATION 2005/04/27	CRÉATEUR / CREATOR lanoieg	PAGE 1 of 1
REVISION PAR / BY trudelj		DESCRIPTION MS-473463LDT5SST			
REVISION DATE 2012/09/04		#DESSIN / DRAWING # MS-473463LDT5SST			REVISION 2



IMS Technologies Inc. reserves all rights in this document. No part of this document may be reproduced, stored in a retrieval system, or transmitted, in any form or by any means, electronic, mechanical, photocopying, recording, or by any information storage and retrieval system, without the prior written permission of IMS Technologies Inc. All rights reserved.
 IMS Technologies Inc. est une société canadienne. Toute réimpression ou utilisation non autorisée sans la permission écrite de la société est formellement interdite. Toute violation de ces droits est strictement interdite. IMS Technologies Inc. se réserve tous droits réservés. Tous droits réservés.

#	Ref.	Q.
1	MP-4623711010	1
2	AU-PLT2MM5	1
3	MT-13232F	1

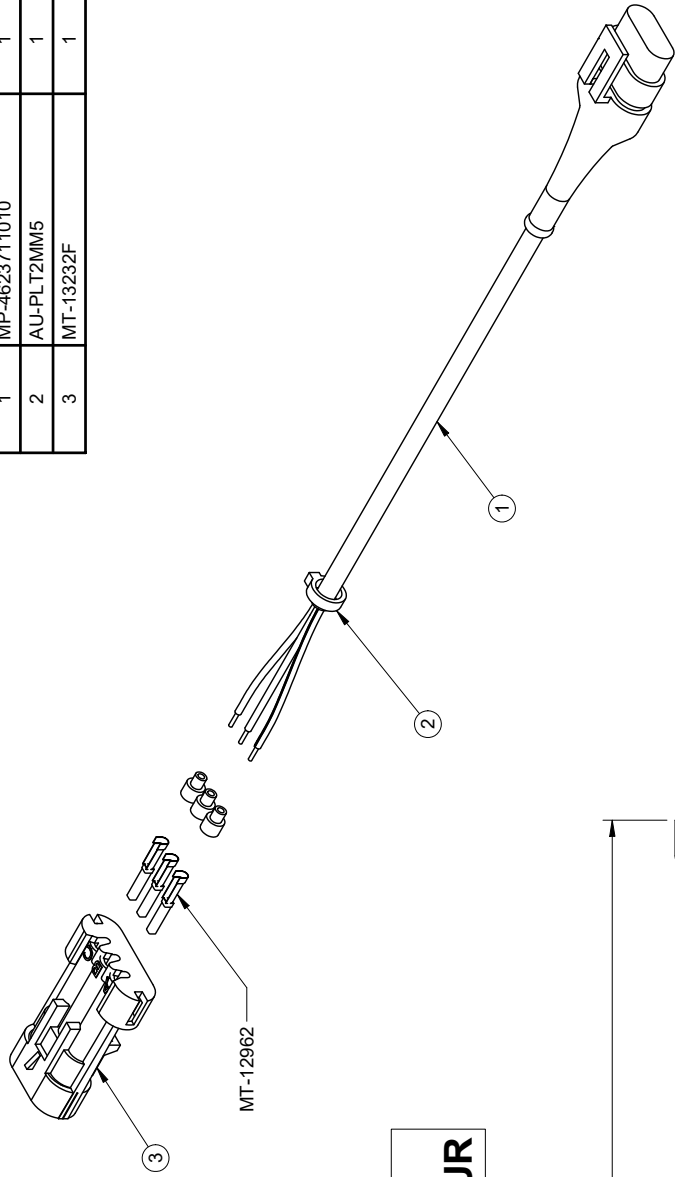

**COULEUR DES FILS
SELON LE FOURNISSEUR**

FOURNISSEUR 1

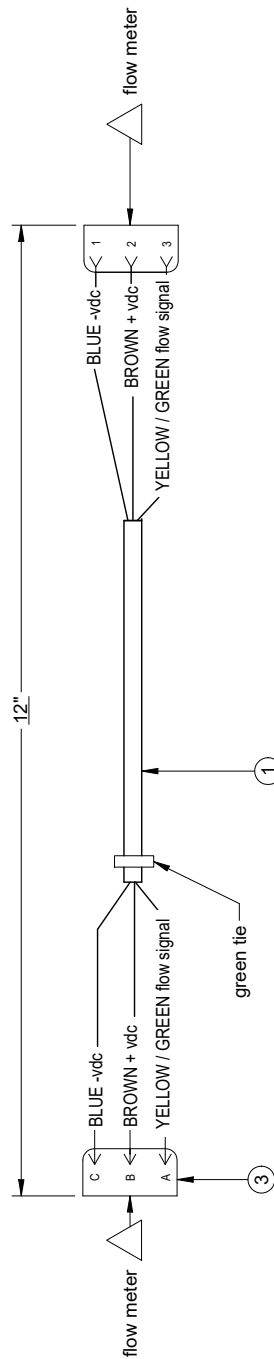

FOURNISSEUR 2

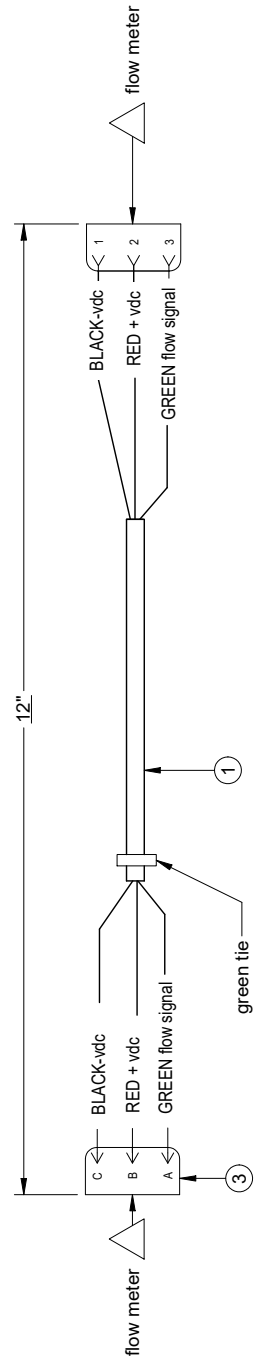

Rev	Description	Date	Approbation

<p>1- LES VALEURS SONT EN POUCES SAUF SI SPECIFIE UNITS ARE IN INCHES UNLESS OTHERWISE SPECIFIED 2- TOLERANCES GENERALES Frac.: ± 1/16" X.XX: ± 0.01" X.XXX: ± 0.005"</p>		<p>AVIS: L'information contenue a été fournie par le fournisseur et MS GREGSON n'assume aucune responsabilité en matière de propriété, licence, droits de reproduction, etc. MS GREGSON, qui réserve all patent rights therein, n'assume aucune responsabilité en matière de propriété, licence, droits de reproduction, etc.</p>	
# FEUILLE / SHEET #	MS-4623711010	DATE CREATION	2006-11-03
CREATEUR / CREATOR	lanoleg	REVISION PAR / BY	trudej
DESCRIPTION	Câble de lecteur de débit électro-magnétique assemblé		
# DESSIN / DRAWING #	MS-4623711010	ECHELLE / SCALE	1:1
PAGE	1 of 1	REVISION	1

#	REF.	Q.	L"
1	AU-33TNHN	1	366"

#	REF.	Q.
2	JB-435EC2D	1
3	JB-45529-3/4	5
4	JB-584561500	1
5	JB-5845614	1
6	JB-RMF0201BR	1
7	AU-D7069-3A	2
8	BT-516114	2
9	BT-FW516	2
10	BT-LN516	2
11	AU-119BA	1
12	BT-FW12	1
13	JB-025FF002004G	1
14	DA-SHAS32	2

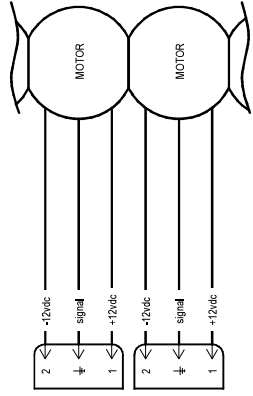
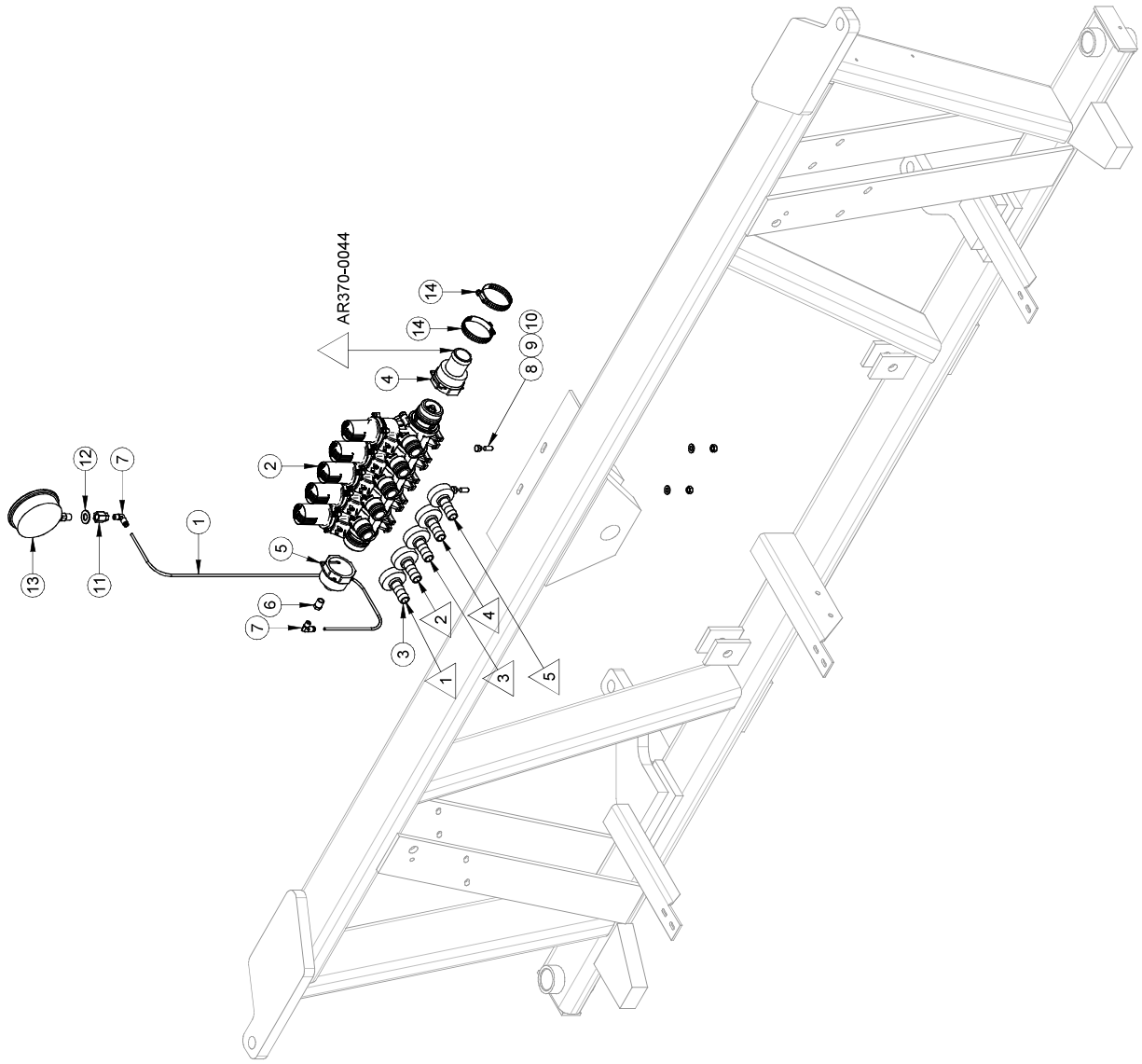

#	Ref.	Q.
1	MT-01311	1
2	AU-BL241010	1
3	AU-406501	2
4	AU-40650101	2
5	AU-400603	1
6	AU-FICIDBOITE	1
7	AU-DECEM3405	1

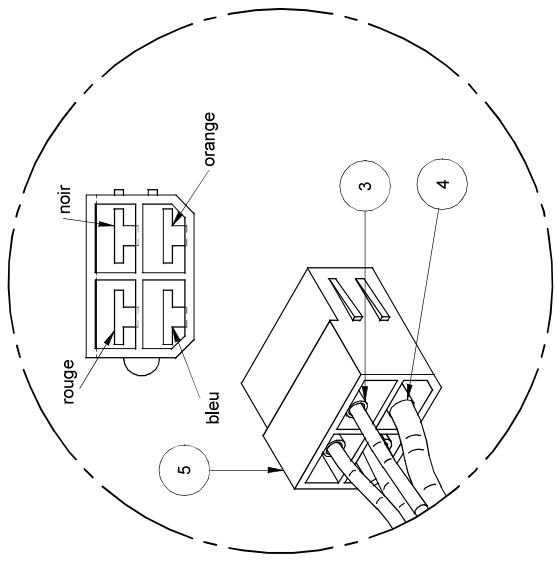
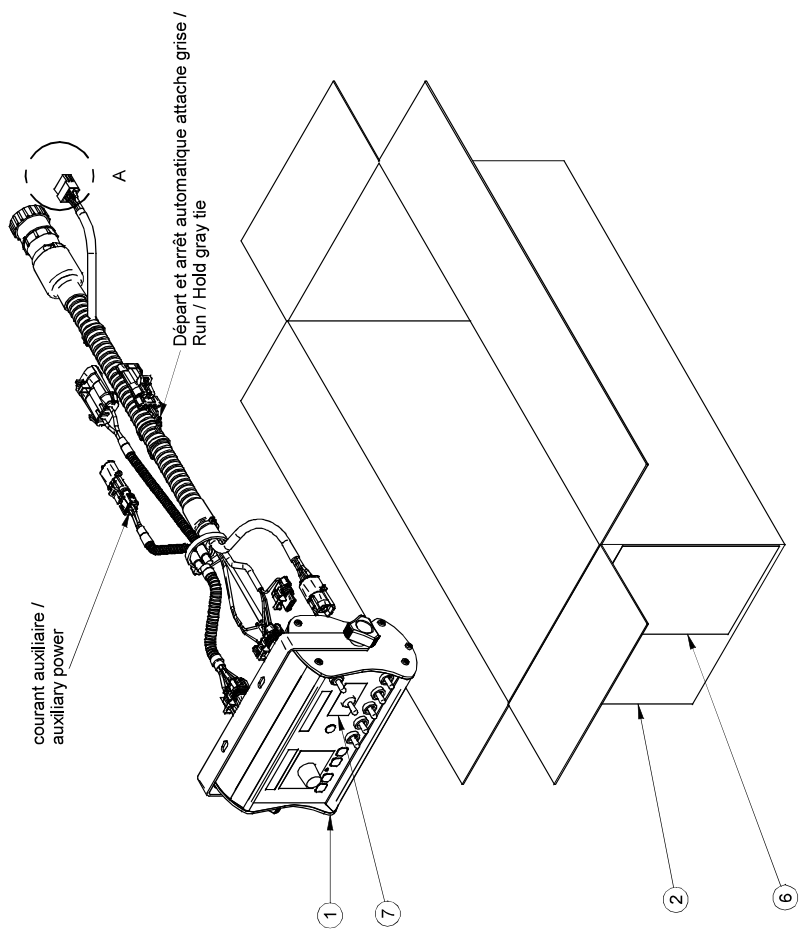

#	Ref.	Q.	"
1	AU-CMC1281	1	
2	AU-CMC1282	1	
3	AU-CMC1283	1	
4	AU-CMC1284	1	
5	AU-CMC1285	1	
6	AU-CMC1286	1	
7	AU-CMC1287	1	
8	MT-14226	1	
9	AU-PLT2MM5	1	
10	AU-A16041ND	1	
11	AU-L8400M	1	
12	AU-WLT1000375100	1	
13	MT-17293	1	
14	MP-ECS0015	4	
15	AU-TUBERET14	4	3"

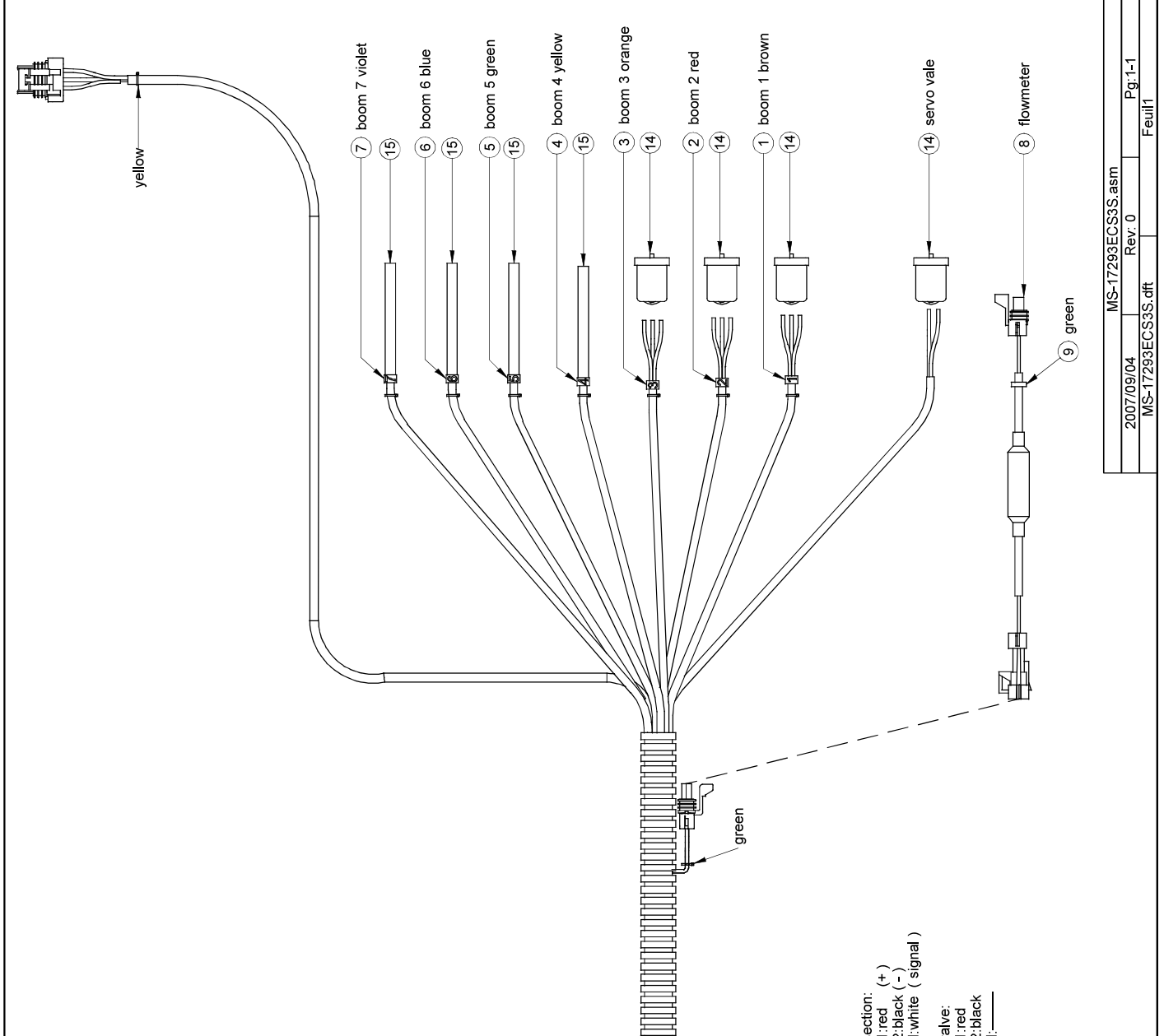

#	Ref.	Q.	"
1	AU-CMC1281	1	
2	AU-CMC1282	1	
3	AU-CMC1283	1	
4	AU-CMC1284	1	
5	AU-CMC1285	1	
6	AU-CMC1286	1	
7	AU-CMC1287	1	
8	MT-14226	1	
9	AU-PLT2MM5	1	
10	AU-WLT1000375100	1	
11	MT-17293	1	
12	MP-ECS0015	6	
13	AU-TUBERET14	2	3"
14	AU-A16041ND	1	
15	AU-LB400M	1	

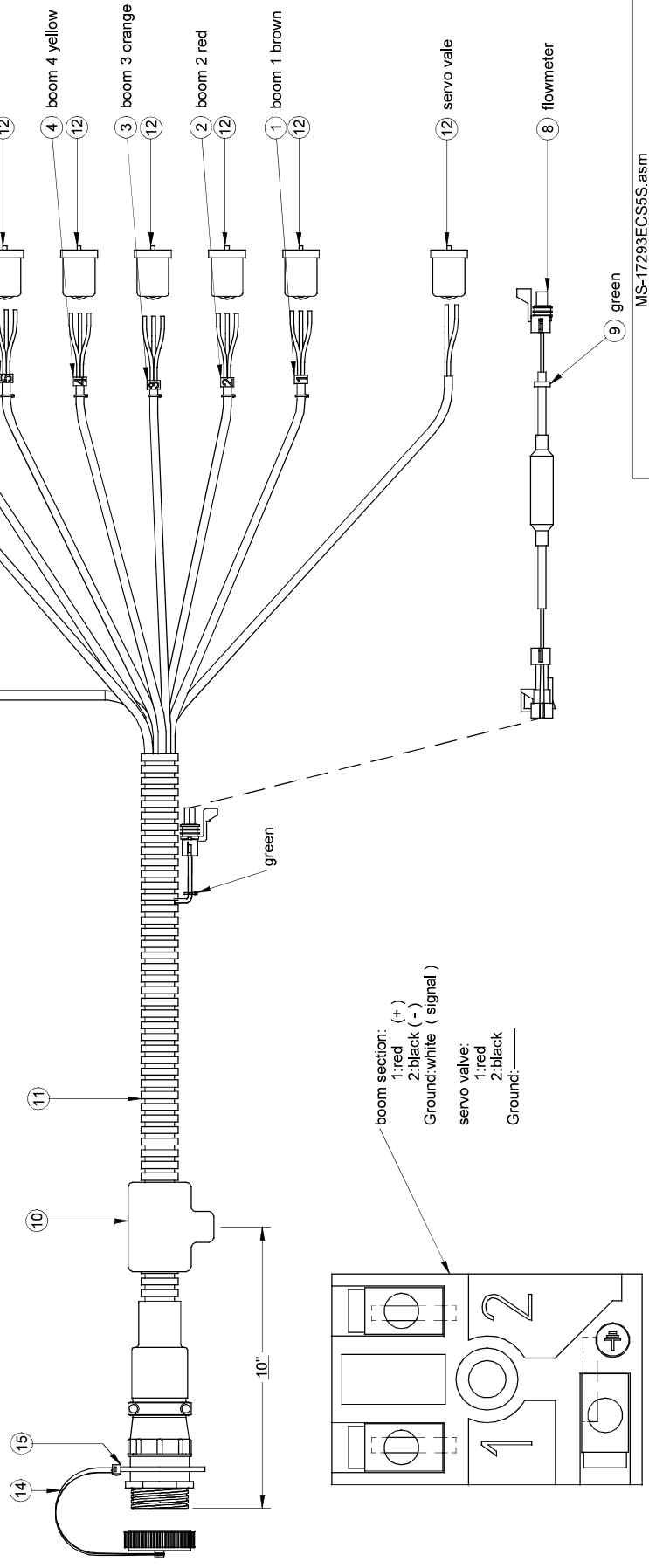

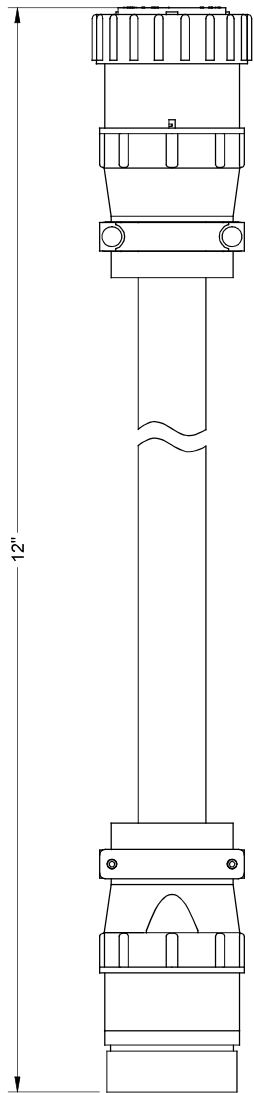

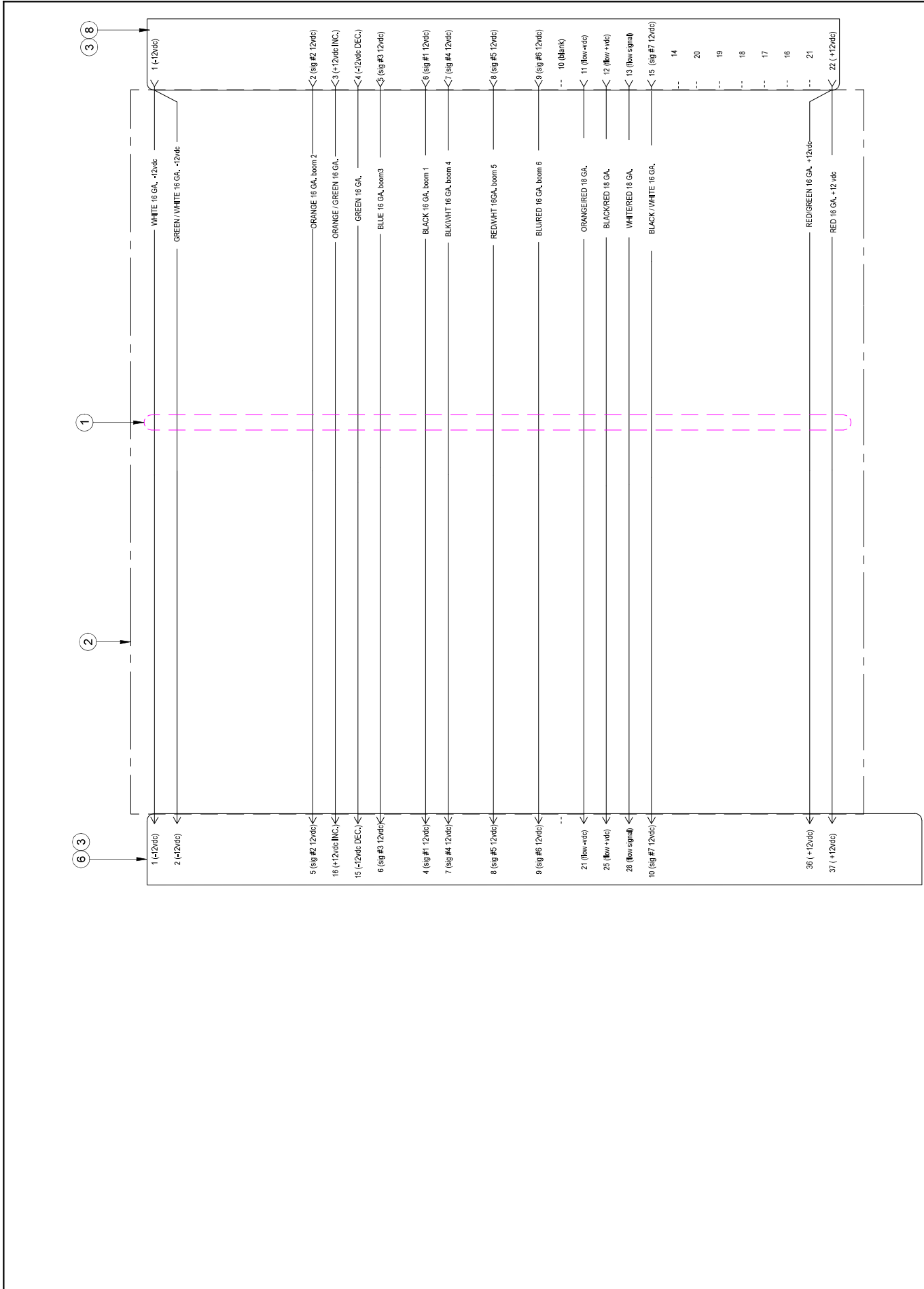

#	Ref.	Q.	"
1	AU-1291	1	7"
2	BE-1624PVC	1	8"

#	Ref.	Q.
1	AU-1291	1
2	BE-1624PVC	1
3	AU-A16037ND	1
4	AU-A16061ND	2
5	AU-A25124ND	13
6	AU-A25036ND	2
7	AU-A1356ND	1
8	AU-A25123ND	16

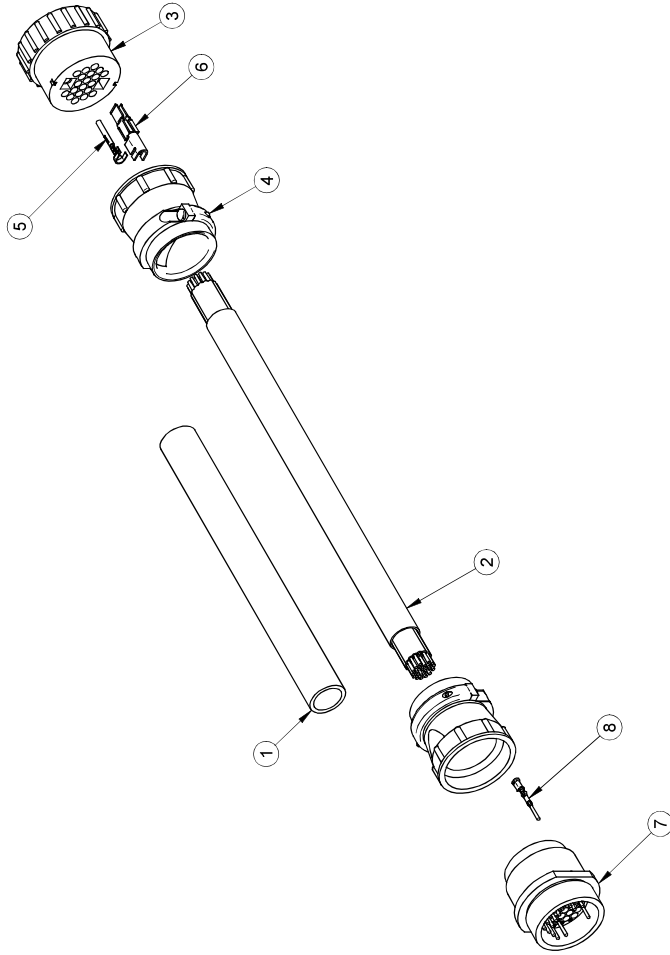

Plomb. hyd. sélecteur 4 fonct. rampe HV
4 fonct. hyd. plumbing for HV boom

RE-PHRHV4F

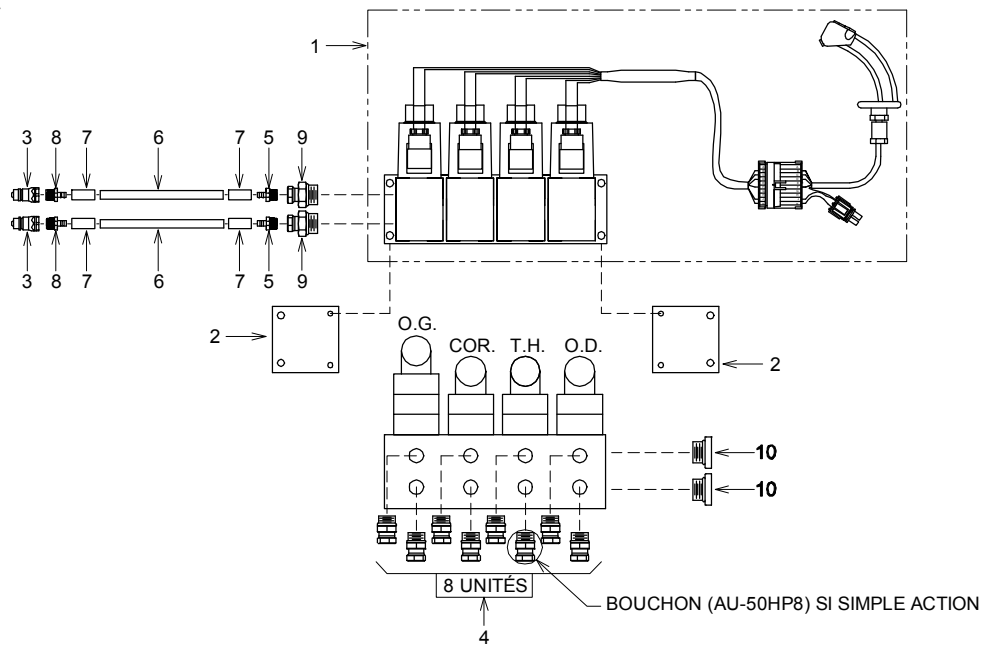

RE-PHRHV3F

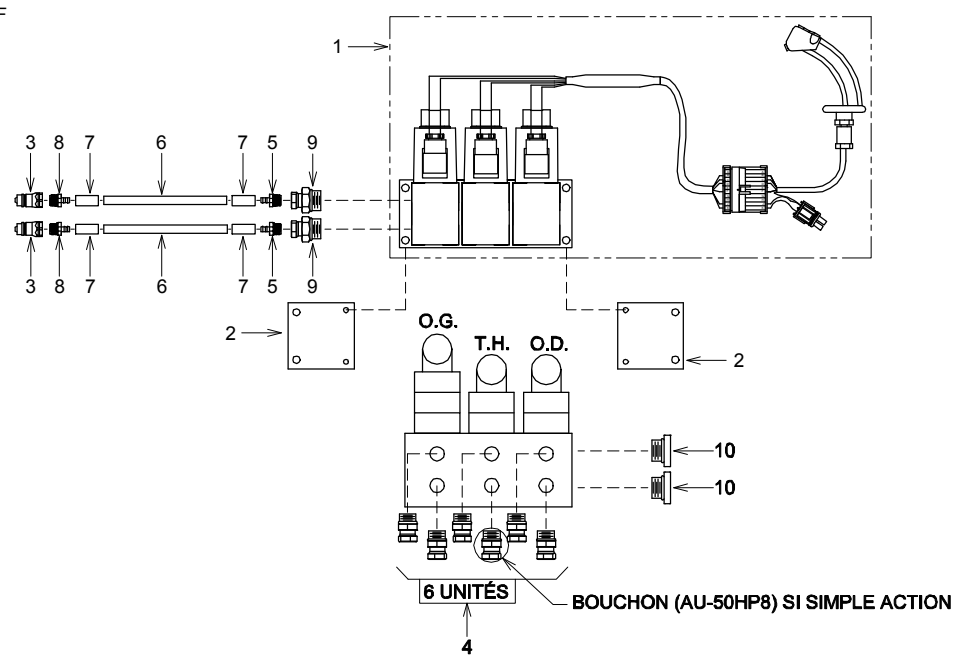

O.G. : OUVERTURE GAUCHE
COR. : CORRECTEUR DE NIVEAU
T.H. : TREUIL HYDRAULIQUE
O.D. : OUVERTURE DROITE



PULVÉRISATEUR MS Inc.
MS SPRAYER Inc.

\\PULVAG\RAMPE\PLOMB-HYD\PHRHV4F

DATE: 1997-03-27

PAR/ BY: G.L.

REV: 2003-08-25

PAR/ BY: E.L.

#REV: 1

REC.: RE-PHRHV4F

RE-PHRHV3F

APP:

APPROUVÉ LE: 2005-04-15 09:54:03 PAR: LANDIEG



MS Gregson Inc.

4300 rue Vachon, Drummondville QC J2B 6V4, Canada
Tél.: 819 474-1910 • Fax : 819 474-5317 • orders@msgregson.com

BOM

RE-PHRHV4F

REVISION

1

Desc. Française Plomb. h yd. sélecteur 4 fonct. rampe HV pour parallélogramme
English Desc. 4 fonct. h yd. plumbing for HV boom for parallelogram

Réf.	Quantité	Produit	Description française	English Description
2	2.00	MS-SEHYDR4	Support embase hydraulique	Hydraulic block brace
3	2.00	MO-80104	Qc à bille fermé hyd. mâle 1/2" x 1/2"fnpt pl***	Close ball coupler male 1/2" x 1/2"fnpt pl***
4	8.00	AU-705088	Raccord droit 3/4-16morb x 1/2"fpnpt	Straight adapt. 3/4-16morb x 1/2"fpnpt
5	2.00	AU-ISN1068HT	Raccord droit 3/8"mnpt x 1/2"hb pour FH-H12 et H122H	Straight fitt. 3/8"mnpt x 1/2"hb for FH-H12and H122H
6	60.00	FH-H122H	Boyau 1/2"x 2plis, noir 4000 lbs/po2, 275oF	Hose 1/2"x 2ply, black 4000 psi, 275oF
7	4.00	AU-IS8SCFHT	Ferrule 1/2"pour boyau FH-H122H	Ferrule 1/2" for hose FH-H122H
8	2.00	AU-ISN1088HT	Raccord droit 1/2"mnpt x 1/2"hb pour FH-H12 et H122H	Straight fitt. 1/2"mnpt x 1/2"hb for FH-H12and H122H
9	2.00	AU-7050106	Raccord pivotant 3/8"pfnpnt x 7/8-14morb pl	Swivel 3/8"pfnpnt x 7/8-14morb pl
10	2.00	AU-50HP10	Bouchon 7/8-14 joint torique boss, mâle tête allen hex	7/8-14 male orb allen hex head plug



MS Gregson Inc.

4300 rue Vachon, Drummondville QC J2B 6V4, Canada
Tél.: 819 474-1910 • Fax : 819 474-5317 • orders@msgregson.com

BOM

MS-ENSRUNHOLD8F

REVISION

0

Desc. Française Ens. de départ et arrêt automatique pour manette 8 fonction
English Desc. Run / hold kit for 8 fonction joystick

Réf.	Quantité	Produit	Description française	English Description
3	1.00	CA-JOYSTICK8S	Levier de commandes 8 inter.avec marche-arrêt (joystick)***	Joystick 8 switch w/on/off ***
21	1.00	MT-13232F	Ens.connecteur femele 3 pins m/p	Connector female kit 3 pins m/p
22	2.00	BE-222PVC	Câble 22/2 pvc 300 volts	Wire #22-2pvc (au pied)
23	1.00	JB-90361600I	O-ring	O-ring
24	6.00	AU-TUBERET38	Tube fondant 3/8" gris	Shrink tubing 3/8"(elec.wire)
26	1.00	AU-PLT2MM8	Attaches pour câbles minis grises	Tie rap mini gray
27	2.00	AU-PLT2MM100	Attaches pour câbles minis noires	Tie rap mini black

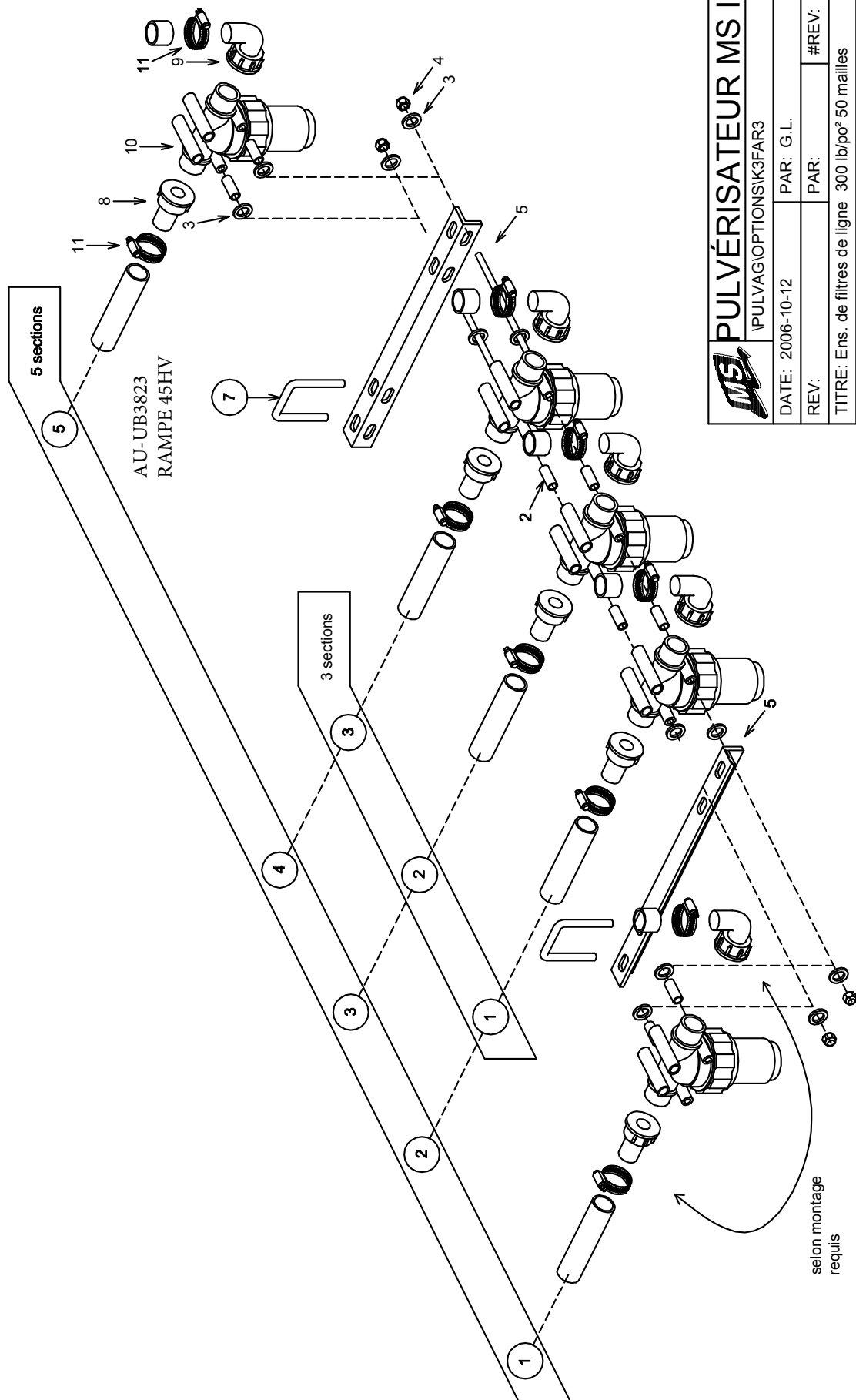

AU-UB3823
RAMPE 45HV

 PULVÉRISATEUR MS Inc. PULVAG OPTIONS K3FAR3	DATE: 2006-10-12	PAR: G.L.
	REV:	PAR:
TITRE: Ens. de filtres de ligne 300 lb/po ² 50 mailles		
# REC.:		
MS-K3F134AR3		
MS-K5F134AR3		
		APP:

selon montage
requis



PULVÉRISATEUR MS
 Div. de RAD Technologies Inc.
 4300 rue Vachon, Drummondville QC J2B 6V4, Canada
 Tél.: 819-474-1910 Fax: 819-474-5317 sales@msspray.com

BOM	MS-K3F134AR3
REVISION	0

Desc. Française **Ens. de 3 filtres 1" de ligne 50 mailles, 300 lb/po² 3/4"**
 English Desc. **3 in-line 1" filter kit, 50 MESH, 300 psi 3/4" hose**

Réf.	Quantité	Produit	Description française	English Description
1	2.00	MS-TF51613	Tige filetée 5/16" x 13"	13", 5/16" threaded rod
2	4.00	MS-BE38114	Bague espaceur 3/8" int x 1 1/4"	3/8" int x 1 1/4" spacer bushing
3	8.00	BT-FW516	Rondelle plate 5/16"	Flat washer 5/16
4	4.00	BT-LN516	Écrou freiné nylon 5/16 unc	Locknut nylon 5/16 unc
5	2.00	MS-BRHV50FJ	Fixation de bar de porte buse	Nozzles support brace
7	2.00	AU-UB38112212	Boulon en U, carré 3/8 x 1 1/2 x 2 1/2	Sq u-bolt 3/8 x 1 1/2 x 2 1/2
8	3.00	MP-1064191	Adapt. droit 1"fnpt x 3/4"hb céd.40 ny***	Straight adaptor 1"fnpt x 3/4"hb ced.40 ny***
9	3.00	MP-1164201	Adapt. coudé 90° 1"fnpt x 3/4"hb céd.40 ny	90° elbow adaptor 1"fnpt x 3/4"hb ced.40 ny
10	3.00	AU-8110009	Filtreur 1" mbsp x 1" mbsp, 290 lbs/po ² , 50 mailles	Strainer 1" mbsp x 1" mbsp, 290 psi, 50 mesh
11	6.00	DA-SHAS12	Collier de serrage en acier inox. 9/16" x 1 1/4"	Stainless steel collar 9/16" x 1 1/4"



MS Gregson Inc.

4300 rue Vachon, Drummondville QC J2B 6V4, Canada
Tél.: 819 474-1910 • Fax : 819 474-5317 • orders@msgregson.com

BOM

MS-K5F134AR3

REVISION

0



Desc. Française Ens. de 5 filtres 1" de ligne 50 mailles,300 lb/po² 3/4"

English Desc. 5 in-line 1" filter kit 300 psi 3/4" hose

Réf.	Quantité	Produit	Description française	English Description
1	2.00	MS-TF51621	Tige filetée 5/16" x 21"	21", 5/16" threaded rod
2	8.00	MS-BE38114	Bague espaceur 3/8" int x 1 1/4"	3/8" int x 1 1/4" spacer bushing
3	12.00	BT-FW516	Rondelle plate 5/16"	Flat washer 5/16"
4	4.00	BT-LN516	Écrou freiné nylon 5/16 unc	Locknut nylon 5/16 unc
5	2.00	MS-BRHV50FJ	Fixation de bar de porte buse	Nozzles support brace
6	4.00	BT-N38	Écrou 3/8" plaqué	Nut 3/8" plated
7	2.00	AU-UB38212312	Boulon en U, carré 3/8 x 2 1/2 x 3 1/2	Sq u-bolt 3/8 x 2 1/2 x 3 1/2
8	5.00	MP-1064191	Adapt. droit 1"fnpt x 3/4"hb céd.40 ny***	Straight adaptor 1"fnpt x 3/4"hb ced.40 ny***
9	5.00	MP-1164201	Adapt. coudé 90° 1"fnpt x 3/4"hb céd.40 ny	90° elbow adaptor 1"fnpt x 3/4"hb ced.40 ny
10	5.00	AU-8110009	Filtreur 1" mbsp x 1" mbsp, 290 lbs/po ² , 50 mailles	Strainer 1" mbsp x 1" mbsp, 290 psi, 50 mesh
11	10.00	DA-SHAS12	Collier de serrage en acier inox. 9/16" x 1 1/4"	Stainless steel collar 9/16" x 1 1/4"

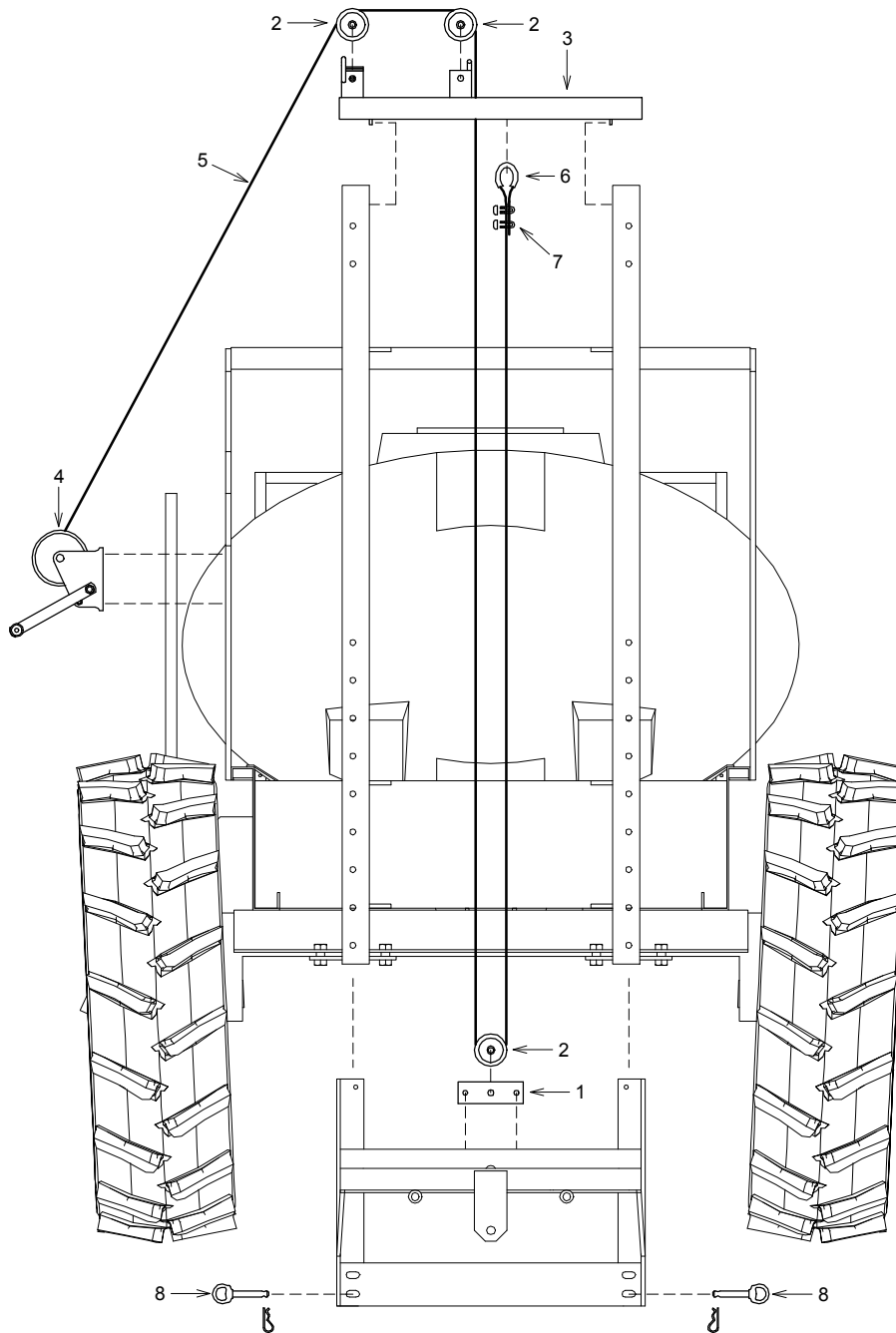
Rellevage manuel pulv. rem. R1915 / T500
 Manual lift kit with winch for R1915 / T500



 PULVÉRISATEUR MS Inc. MS SPRAYER Inc.		
DATE: 2003-11-19	PAR/ BY: E.L.	
REV: 2007-07-03	PAR/ BY: D.T.	#REV: 2
# REC.: MS-TMBR1915		
		APP: 

APPROUVÉ LE: 2007-07-18 08:29:54 PAR: LANDIEG



MS Gregson Inc.

4300 rue Vachon, Drummondville QC J2B 6V4, Canada
Tél.: 819 474-1910 • Fax : 819 474-5317 • orders@msgregson.com

BOM

MS-TMBR1915

REVISION

2

Desc. Française Relevage manuel pour T300 à R1915, P1135E- P1915

English Desc. Manual lift kit for T300 to R1915, P1135E- P1915

Réf.	Quantité	Produit	Description française	English Description
1	1.00	MS-BSAE	Bracket treuil manuel	Manuel winch bracket
2	3.00	AU-133103	Poulie 1/2 arbre x 3" pour	Pulley 1/2" shaft x 3" for
3	1.00	MS-TT1915R2	Tête de treuil manuel	Manual winch interface
4	1.00	CA-514	Treuil 1400 lbs	Winch 1400 pounds
5	1.00	MS-CA0010	Cable 1/4" x 240"	1/4" x 240" steel cable
6	1.00	MO-DD119606	Cosse cable acier 1/4	Thimble/steel cable 1/4
7	2.00	MO-DD119506	Clip pour cable 1/4	Clip/steel cable 1/4
8	2.00	AU-HP0814	Goupille 1/2"x3 1/2" anneau rond	Pin 1/2" x 3 1/2" round ring

Relevage hyd. par glissière 20" de course HYD LIFT KIT, 20" RAISE

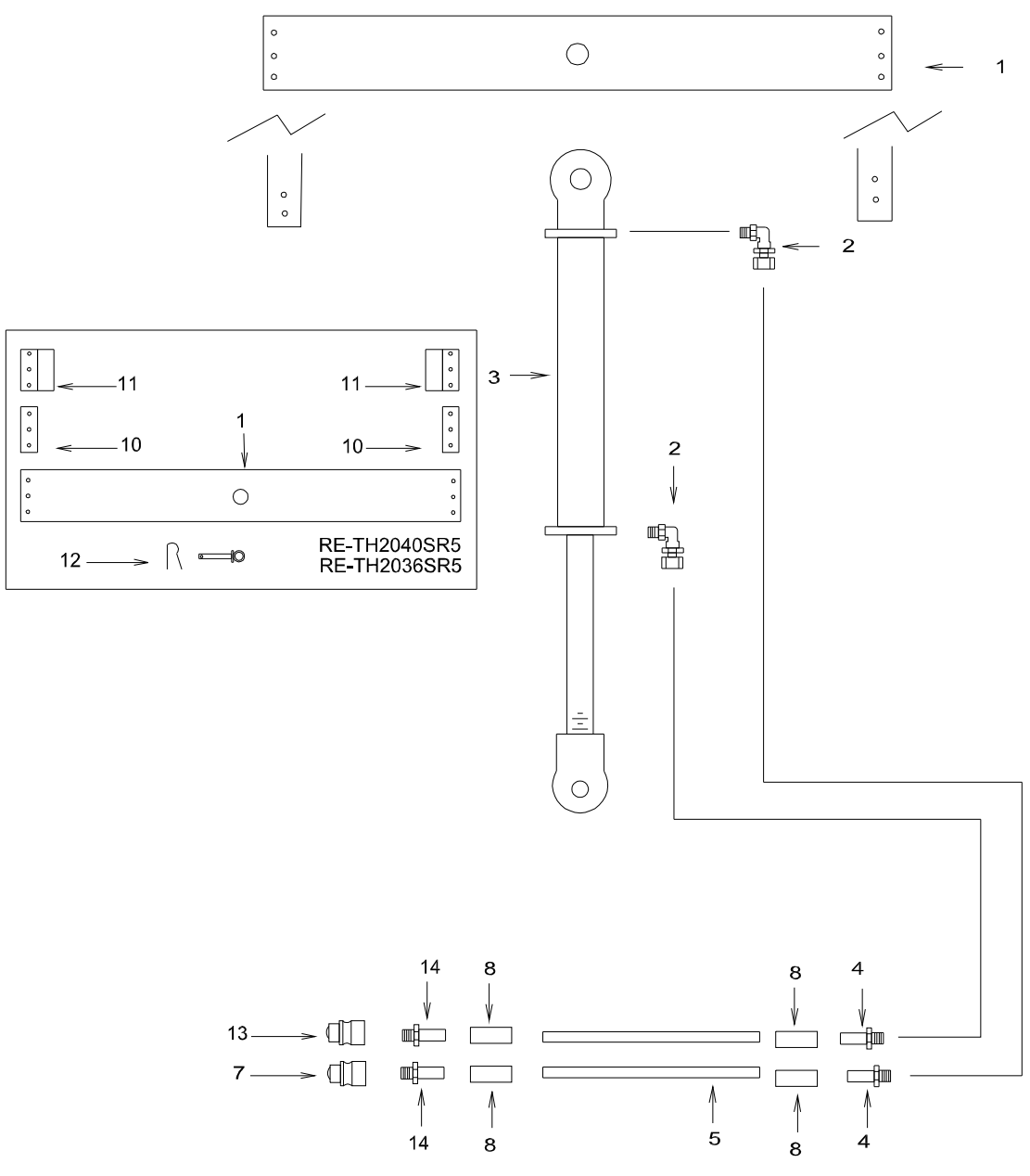

		PULVÉRISATEUR MS Inc.	
		MS SPRAYER Inc.	
I/PULVAGRAMPE/RELEVAGE/ITH2040R5			
DATE: 1996-04-09	PAR/ BY: G.L.		
REV: 2003-03-10	PAR/ BY: P.B.	#REV: 2	
# REC.: RE-TH2040R5 RE-TH2040SR5			
RE-TH2036R5 RE-TH2036SR5			
			APP:

APPROUVÉ LE: 2003-03-20 09:07 PAR: HOUEB



MS Gregson Inc.

4300 rue Vachon, Drummondville QC J2B 6V4, Canada
Tél.: 819 474-1910 • Fax : 819 474-5317 • orders@msgregson.com

BOM

MS-TH2040R5

REVISION

0

Desc. Française Relevage h yd. par glissière 20" de course

English Desc. Cyl. kit 20-40" / h yd. lift

Réf.	Quantité	Produit	Description française	English Description
1	1.00	MS-STH2040	Support treuil hyd 20 a 40 po	Hyd. winch support 20 to 40"
2	2.00	MO-951586	Adapt. coudé 3/4-16morb x 3/8"pfnpt céd.80 pl	Elbow adapt. 3/4-16morb x 3/8"pfnpt ced.80 pl
3	1.00	MI-648475R2	Cylindre soudé 2" x 20" x 1 1/8" nt, 3/4-16 forb, seal PSP	Cylinder welded 2" x 20" x 1 1/8" nt, 3/4-16 forb, PSP seal
4	2.00	AU-ISN1064	Raccord droit 3/8"mnpt x 1/4"hb céd.80 pl	Straight fitt. 3/8"mnpt x 1/4"hb ced.80 pl
5	49.00	FH-H14	Boyau hydraulique 1/4", 1pli, 3000 lbs/po2	Hyd. hose 1/4", 1 ply, 3000 psi
7	1.00	MO-80104	Qc à bille fermé hyd. mâle 1/2" x 1/2"fnpt pl***	Close ball coupler male 1/2" x 1/2"fnpt pl***
8	4.00	AU-IS4SCF	Ferrule 1/4" céd.80 pl.	Ferrule 1/4" ced.80 pl.
13	1.00	MO-80104EC	Coupleur hyd. 1/2" mâle, conn. pression	1/2" male hyd. coupl.poppet-con.under press.
14	2.00	AU-ISN1084	Raccord droit 1/2"mnpt x 1/4"hb céd.80 pl	Straight fitt. 1/2"mnpt x 1/4"hb ced.80 pl

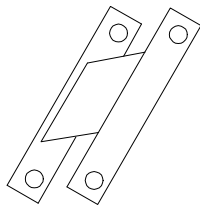
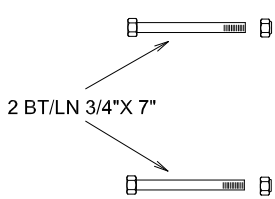
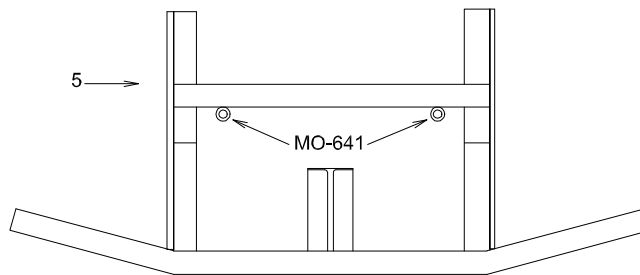

TREUIL ET OSCILLATEUR / RAMPE 50 ET 60 PI. HV
 SLIDER AND SELF LEVELLING DEVICE / 50 AND 60 F. HV BOOM

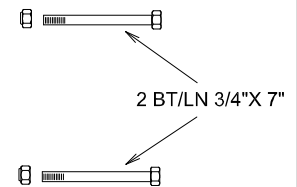
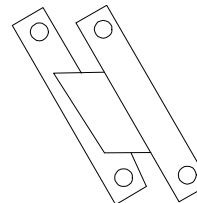

← 8 →



DECGR25H ← 4

		PULVÉRISATEUR MS Inc.	
		MS SPRAYER Inc.	
PULVAG RAMPE OSC-SUSP TROS60V6			
DATE: 1996-04-11	PAR/ BY: R.D.		
REV: 2004-02-09	PAR/ BY: E.L.	#REV: 2	
# REC.: RE-TROS60V6			
			APP: 

APPROUVÉ LE: 2004-02-11 13:50 PAR: LANOIEG



MS Gregson Inc.

4300 rue Vachon, Drummondville QC J2B 6V4, Canada

MS GREGSON Tél.: 819 474-1910 • Fax : 819 474-5317 • orders@msgregson.com

BOM

RE-TROS60V6

REVISION

0

Desc. Française Oscillateur et glissière rampe HV

English Desc. Slider and self level for HV boom

Réf.	Quantité	Produit	Description française	English Description
4	1.00	AU-DECGR25H	Autocollant graisser au 25 hres 1" x 2"	Decal "grease every 25h"
5	1.00	MS-OSC18VT	Treuil oscillateur r60' verti.	Oscillator winch / r60' vert.
8	2.00	MS-OSC07	Un bras d'oscillateur	One self levelling arm

AUTO-NIVELLANT SELF-LEVELLING

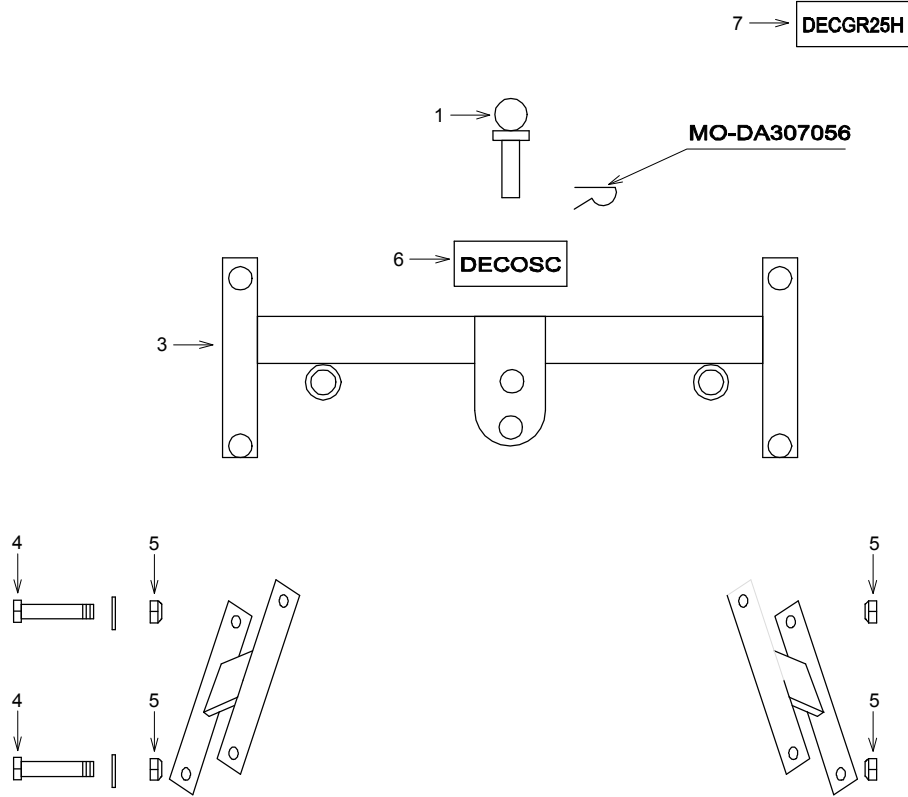

MS		PULVÉRISATEUR MS Inc.	
		MS SPRAYER Inc.	
\PULVAG\RAMPE\OSC-SUSP\OSCR5			
DATE: 1996-04-10	PAR/ BY: R.D.		
REV: 2004-08-25	PAR/ BY: E.L.	#REV: 1	
# REC.: MS-OSCR5			
			APP:

APPROUVÉ LE: 2008-09-23 16:31:15 PAR: LANDIEG



MS Gregson Inc.

4300 rue Vachon, Drummondville QC J2B 6V4, Canada

M S G R E G S O N Tél.: 819 474-1910 • Fax : 819 474-5317 • orders@msgregson.com

BOM

MS-OSCR5

REVISION

0

Desc. Française Oscillateur fixe boulonable

English Desc. Bolted frame kit/arms /self-l.

Réf.	Quantité	Produit	Description française	English Description
1	1.00	MS-OSC05	Pin oscillateur 3/4"x2 1/2"uti	Oscillator pin 3/4" x 2 1/2"
2	2.00	MS-OSC07	Un bras d'oscillateur	One self levelling arm
3	1.00	MS-OSC02	Bâti d'oscillateur	Oscillator frame
4	4.00	BT-347SP	Boulon 3/4" x 7" nc spécial 1 1/8" fileté	Bolt 3/4" x 7" nc spec 1 1/8" threaded
5	4.00	BT-LN34	Écrou freiné nylon 3/4 unc	Locknut nylon 3/4 unc
6	1.00	AU-DECOSC	Autocollant ne jamais verrouiller	Decal never lock
7	1.00	AU-DECGR25H	Autocollant graisser au 25 hres 1" x 2"	Decal "grease every 25h"

Correcteur de niveau hydraulique
Hydraulic level corrector

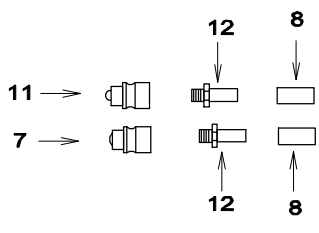
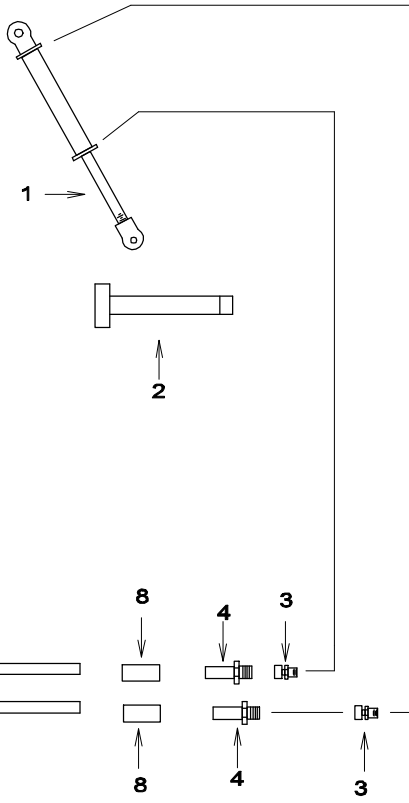
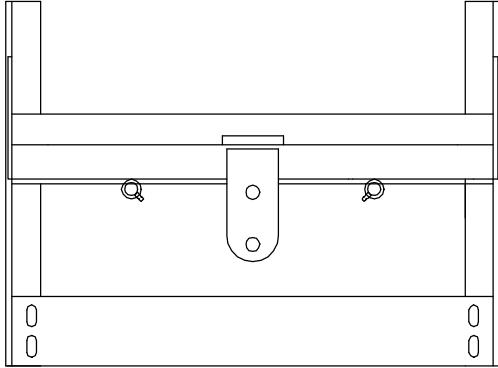

PULVÉRISATEUR MS Inc.
MS SPRAYER Inc.

PULVAGRAMPE\OSC-SUSP\CORNIVR5		
DATE: 1996-04-09	PAR/ BY: G.L.	
REV: 2004-02-09	PAR/ BY: E.L.	#REV: 2
# REC.: MS-CORNIVR5		
		APP:

APPROUVÉ LE: 2006-10-26 10:55:09 PAR: LANDIEG



MS Gregson Inc.

4300 rue Vachon, Drummondville QC J2B 6V4, Canada
Tél.: 819 474-1910 • Fax : 819 474-5317 • orders@msgregson.com

BOM

MS-CORNIVR5

REVISION

0



Desc. Française Ens. de correcteur de niveau pour rampe manuel / HV

English Desc. Hydraulic level corrector for manual and HV boom

Réf.	Quantité	Produit	Description française	English Description
1	1.00	AU-CYL2505	Cylindre 2 1/2" x 4"x 1 1/2" tige en chrome, 3/8 fnpt	Cylinder 2 1/2"x 4"x 1 1/2" cr 3/8 fnpt level cor.
3	2.00	MO-HSR6610400	Orifice 3/8"mnpt x 3/8"pnpt. perce à 0.0400", ID noir	Restrictor 3/8x3/8 drill .0520" black mark
4	2.00	AU-ISN1064	Raccord droit 3/8"mnpt x 1/4"hb céd.80 pl	Straight fitt. 3/8"mnpt x 1/4"hb ced.80 pl
5	60.00	FH-H14	Boyau hydraulique 1/4", 1pli, 3000 lbs/po2	Hyd. hose 1/4", 1 ply, 3000 psi
7	1.00	MO-80104	Qc à bille fermé hyd. mâle 1/2" x 1/2"fnpt pl***	Close ball coupler male 1/2" x 1/2"fnpt pl***
8	4.00	AU-IS4SCF	Ferrule 1/4" céd.80 pl.	Ferrule 1/4" ced.80 pl.
10	-1.00	MS-OSC07	Un bras d'oscillateur	One self levelling arm
11	1.00	MO-80104EC	Coupleur hyd. 1/2" mâle, conn. pression	1/2" male hyd. coupl.poppet-con.under press.
12	2.00	AU-ISN1084	Raccord droit 1/2"mnpt x 1/4"hb céd.80 pl	Straight fitt. 1/2"mnpt x 1/4"hb ced.80 pl

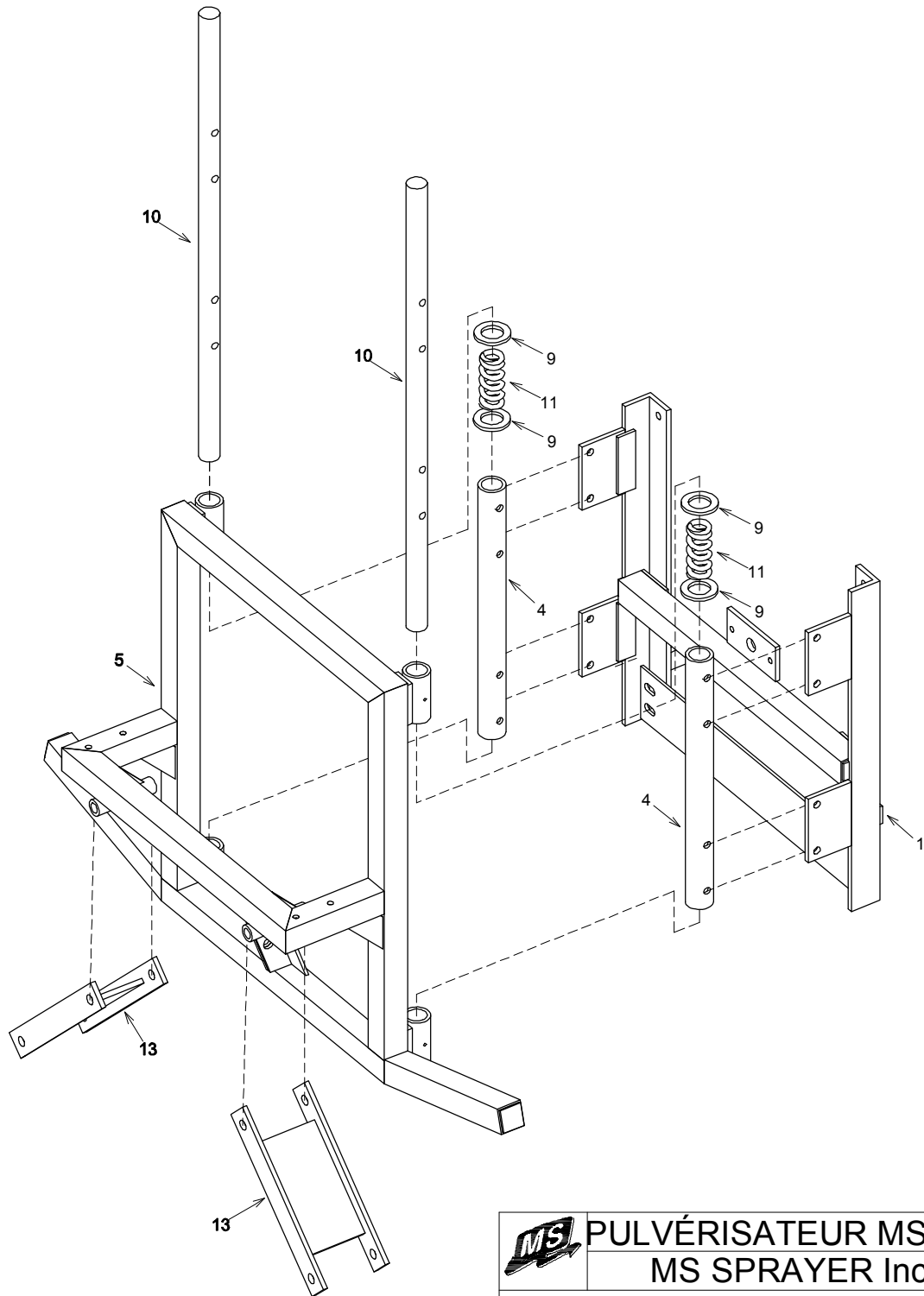
Suspension à ressort, bâti de relevage et oscillateur HV
 Spring suspension for R50/60HV



 PULVÉRISATEUR MS Inc. MS SPRAYER Inc.			
		\PULVAG\RAMPE\OSC-SUSP\SUSRESHVR1	
DATE: 2004-01-30	PAR/ BY: E.L.		
REV: 2004-03-24	PAR/ BY: E.L.	#REV: 0	
# REC.: MS-SUSRESHVR1			
			APP: 

APPROUVÉ LE: 2004-10-28 11:36:54 PAR: LANDIEG



MS Gregson Inc.

4300 rue Vachon, Drummondville QC J2B 6V4, Canada
Tél.: 819 474-1910 • Fax : 819 474-5317 • orders@msgregson.com

BOM

MS-SUSRESHVR1

REVISION

0

Desc. Française Suspension à ressort, bâti de relevage et oscillateur HV
English Desc. Spring suspension for R50/60HV

Réf.	Quantité	Produit	Description française	English Description
1	1.00	MS-BSRHVR	Glissière suspension ressort	Spring suspension slider
4	2.00	MS-TM0067	Bague 2" x 1.516" x 21 1/2", 4 trous	
5	1.00	MS-BSRHVA	Oscillation suspension r60hv	R60HV Suspension oscillator
9	4.00	MS-FW1916212	Rondelle 1 9/16" int. x 2 1/2" ext.	1 9/16" int. x 2 1/2" ext. flat washer
10	2.00	MS-FR0032	Glissière 1 1/2" x 36", 4 trous	1 1/2" x 36" Slider, 4 holes
11	2.00	MS-F04102	Ressort compression 4 1/8"	4 1/8" compression spring
13	2.00	MS-OSC07	Un bras d'oscillateur	One self levelling arm

Montage pour rampe RF
 Assembly for RF boom

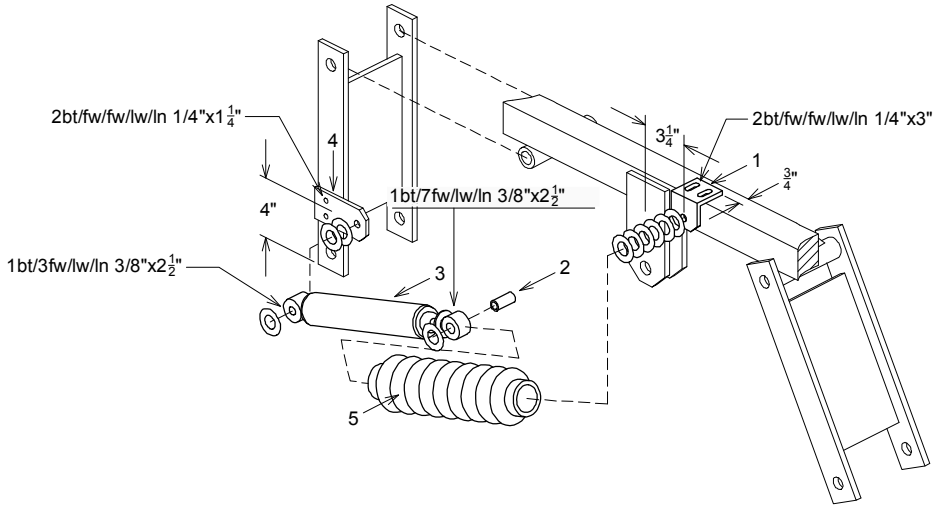

Montage pour rampe HV
 Assembly for HV boom

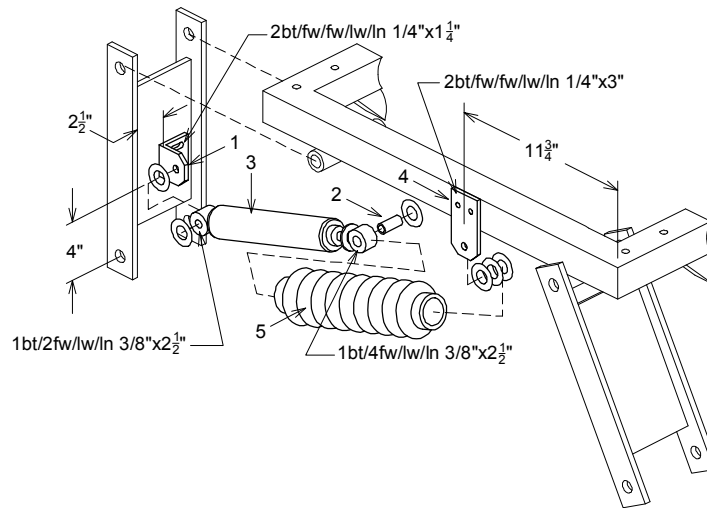

	PULVÉRISATEUR MS Inc.		
	PULVAGIRAMPEIOSC-SUSPAOMS		
DATE: 2004-08-19	PAR: E.L.		
REV: 2004-08-19	PAR: E.L.	#REV: 3	
TITRE: Amortisseur d'oscillation universelle			
# REC.: MS-AOMS			
			APP:

APPROUVE LE: 2004-08-19 13:46:34 PAR: SUTTONT



Desc. Française Ens. d'amortisseur d'oscillation universelle
English Desc. Universal oscillation shock absorber kit

Réf.	Quantité	Produit	Description française	English Description
1	1.00	MS-SAOSC	Sup. amortisseur oscillation	Oscillator shock support
2	1.00	MS-BAOSC	Bushing amorti. oscillateur	Oscillator shock bushing
3	1.00	AU-SC2942	Amortisseur sc2942 Monroe noir	Schock sc2942 Monroe black
4	1.00	MS-SAOSCCB	Sup. amort. oscill. rampe cb	Shock sup. for cb boom oscil.
5	1.00	AU-SA1997	Soufflet pour amortisseur	Boot for shock

#	REF.	Q.
1	BT-N14	4
2	BT-LW14	4
3	BT-FW14	8
4	BT-LN38	2
5	BT-FW38	10
6	MS-BAOSC	1
7	AU-SA1997	1
8	MS-SAOSCCB	1
9	BT-38212	2
10	BT-143	2
11	AU-SC2942	1
12	MS-SAOSC	1
13	BT-14114	2

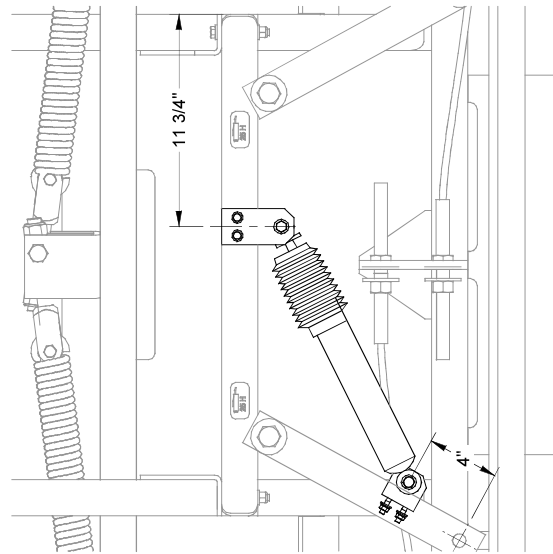
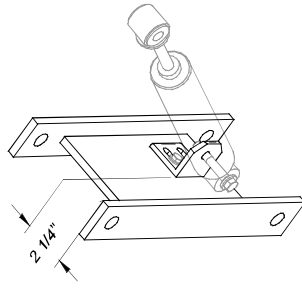

2010/02/04	Pg:1-1
ART20-0001	Rev: 0

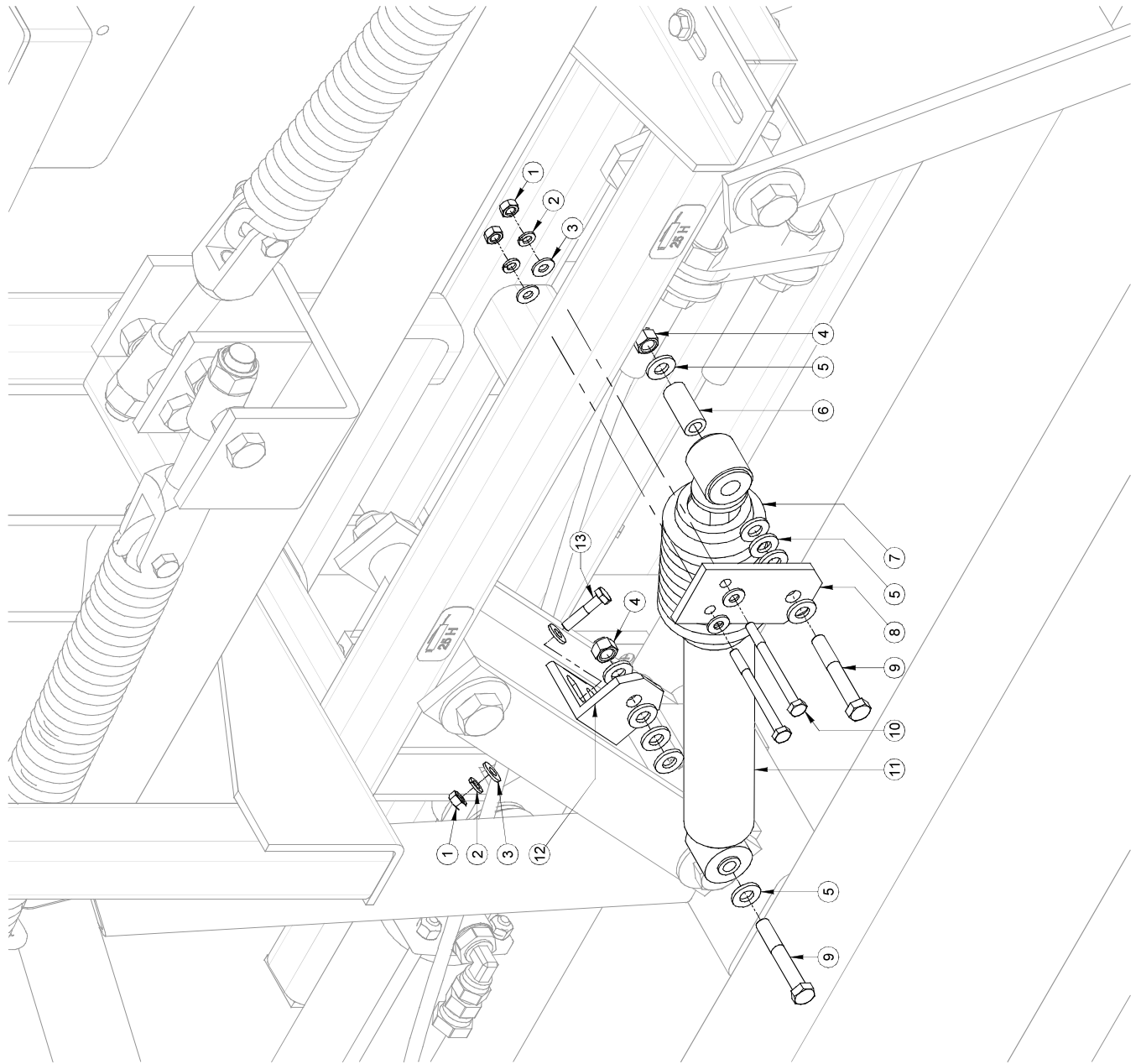

#	REF.	Q.	L"
23	FH-H14	2	22"
24	FH-H14	2	155"
25	FH-H14	2	165"

#	REF.	Q.
1	BT-34612SP	2
2	MO-641	6
3	MS-BR8ETR3	1
4	BT-FW34SAE	4
5	BT-LN34	2
6	AU-DECGR25H	6
7	MS-BR8ATR3	1
8	AU-DECAVER19	1
9	MS-BR8FTR3	1
10	AU-JBR1141182	4
11	DA-BV38FL	2
12	MO-HSR661	2
13	AU-HSN1064	8
14	AU-HS4SCF	12
15	BT-FW14	8
16	BT-LN14	8
17	AU-HSN1084	4
18	MO-951586	4
19	AU-L5305C	6
20	MO-80104	4
21	AU-L5304C	6
22	MI-648400	2

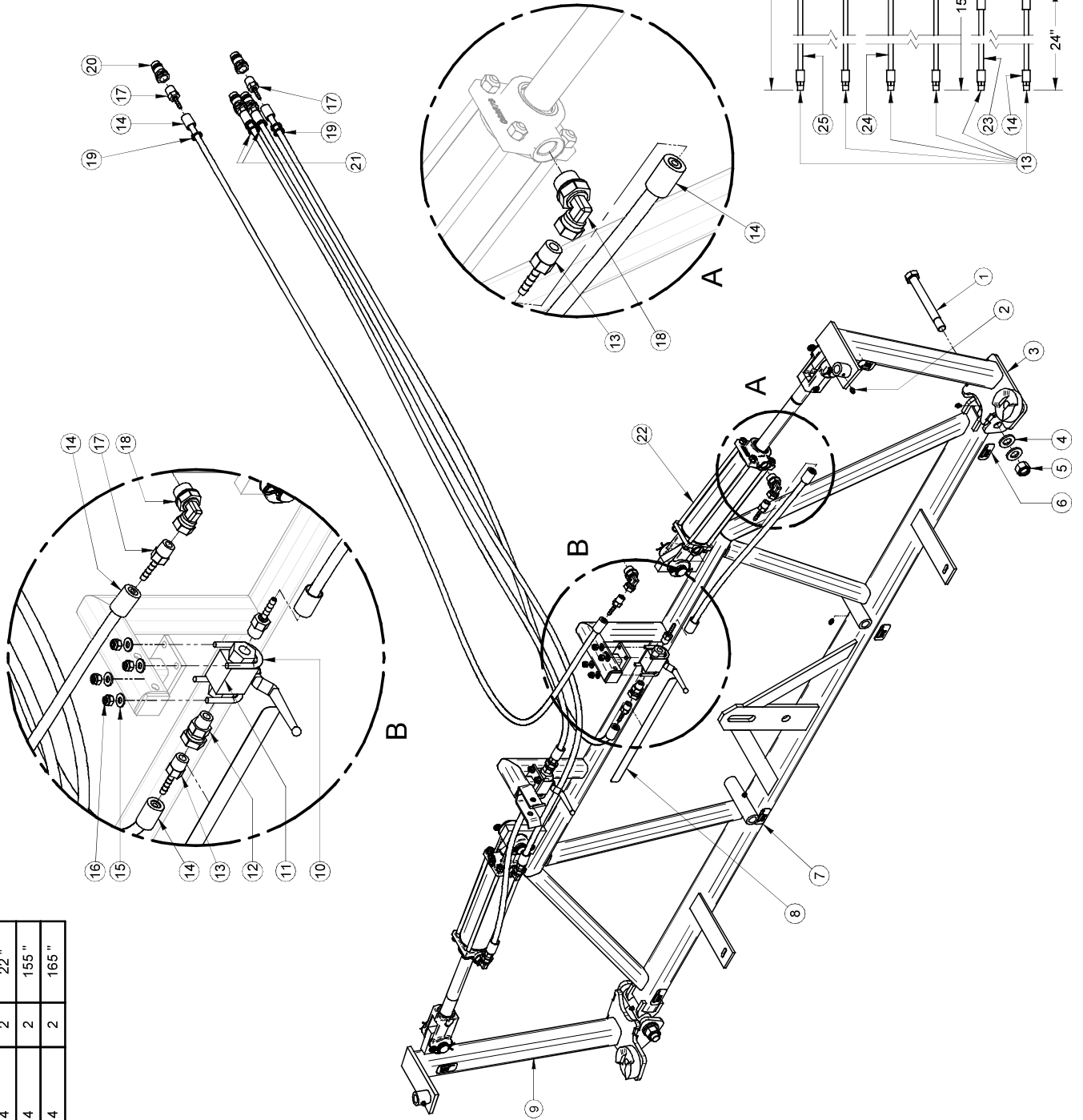

#	REF.	Q.
1	BT-LN12	2
2	BT-FW12	4
3	MS-BR8H	1
4	BT-12112	2
5	GHMUN-002	2
6	BT-14114TF	4
7	BT-FW14SS	4
8	BT-LN14SS	4

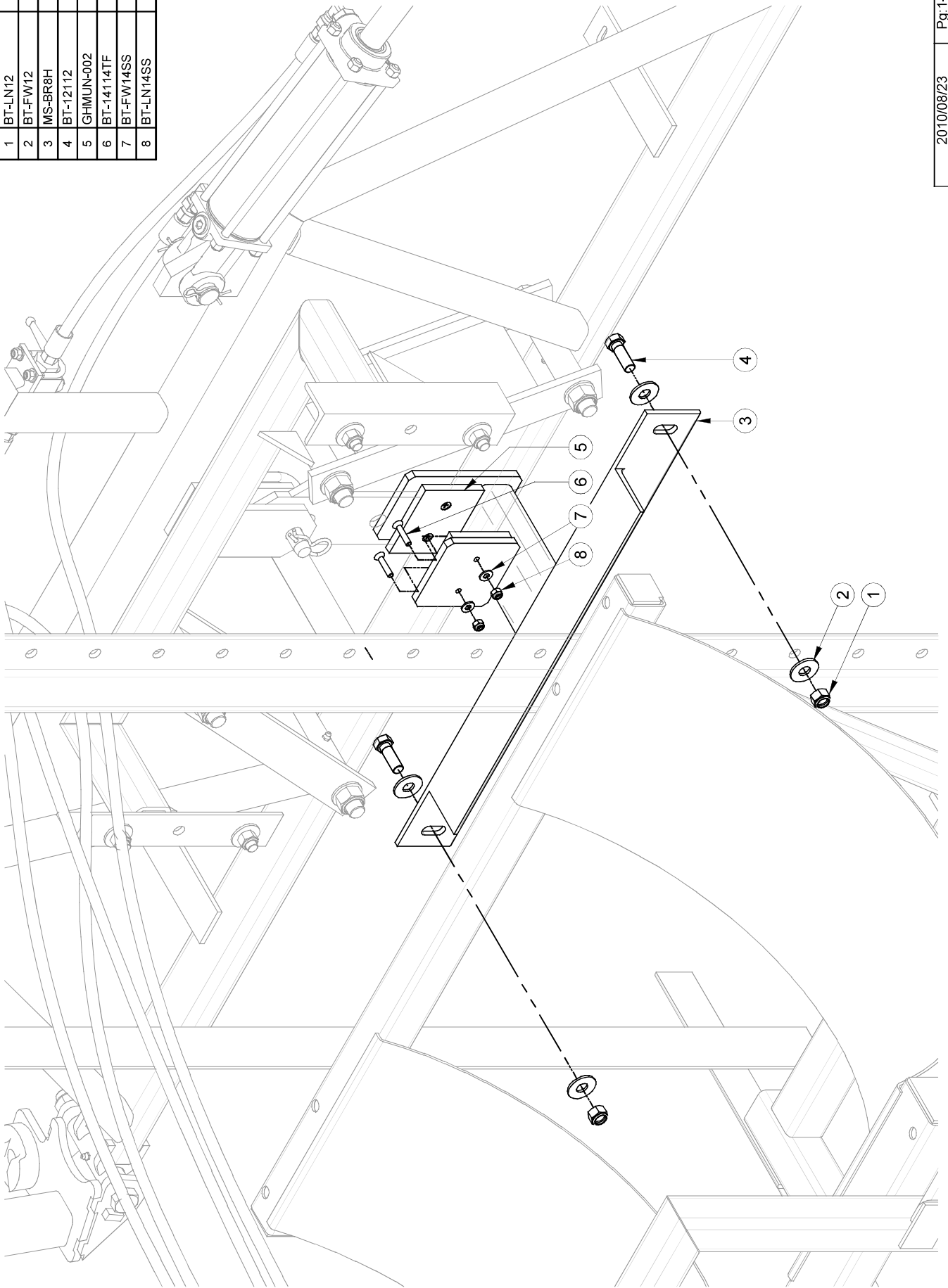

#	REF.	Q.
1	BT-LN12	2
2	MS-BR8HA	1
3	BT-FW12	4
4	BT-12112	2
5	BT-LN14SS	4
6	BT-FW14SS	4
7	BT-14114TF	4
8	GHMUN-002	2

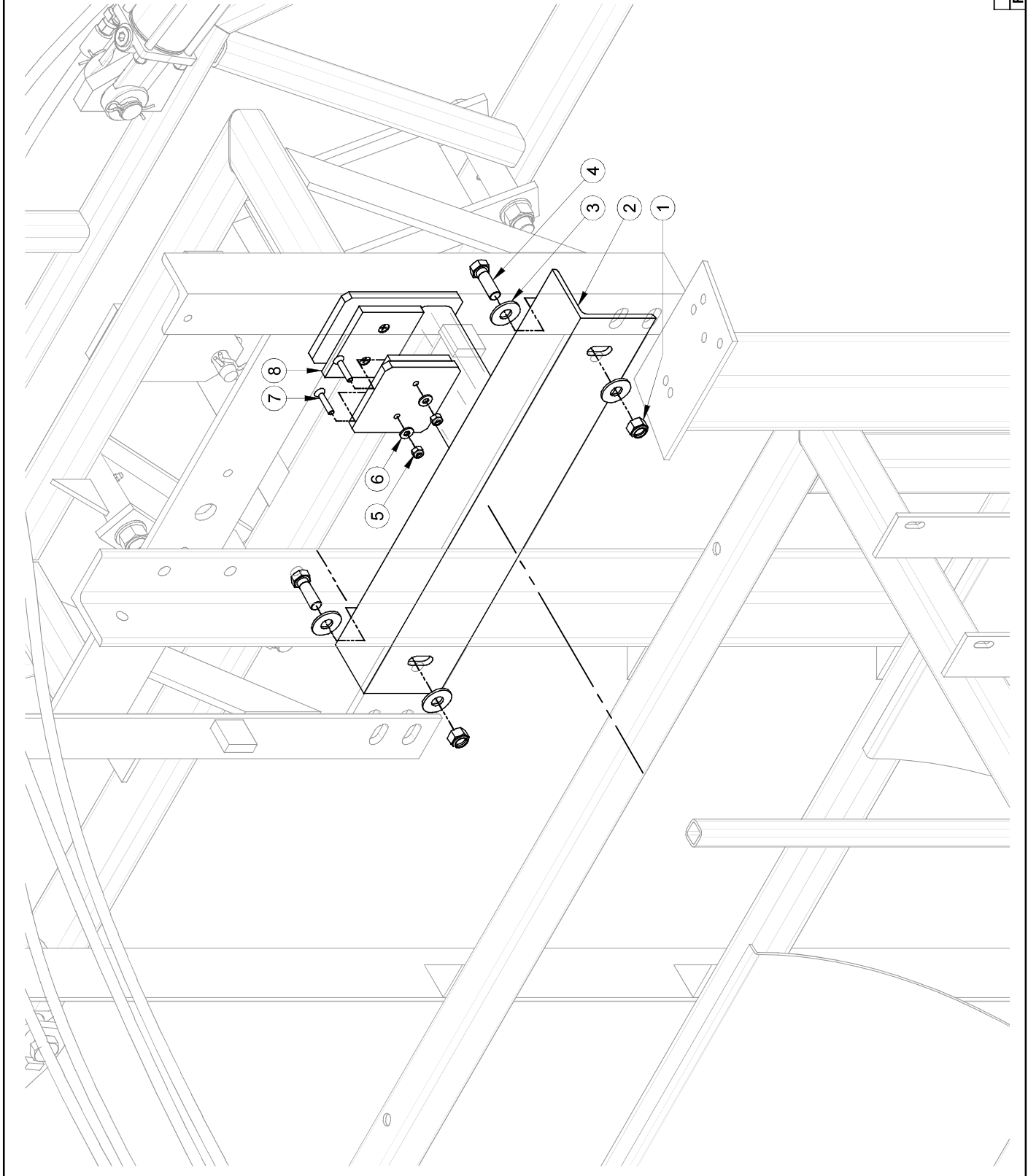

#	REF.	Q.
1	BT-FW38	16
2	A790-0013	1
3	BT-383	8
4	A790-0012	2
5	MS-BRH15S	2
6	AU-SBS612	2
7	BT-LN38	8

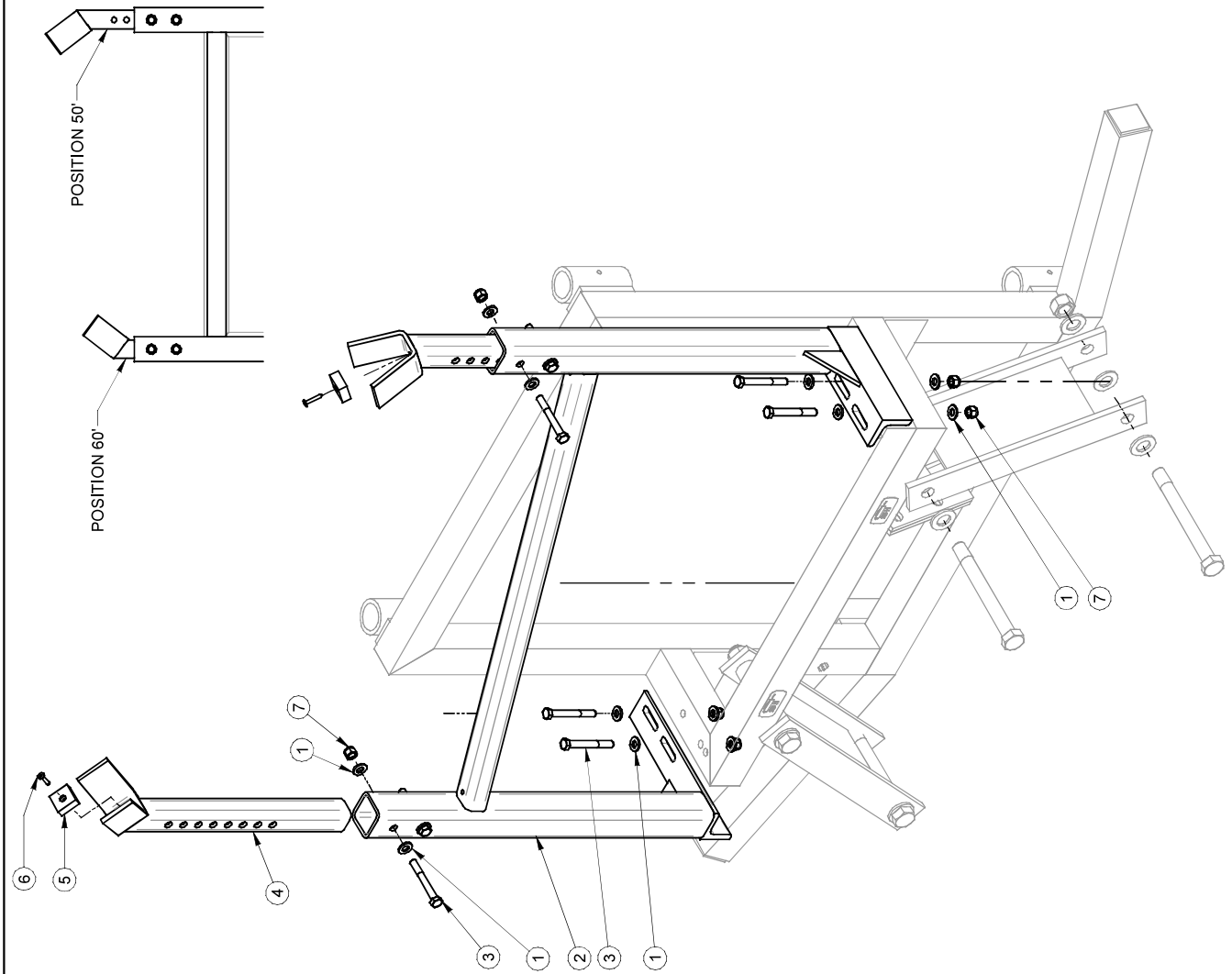

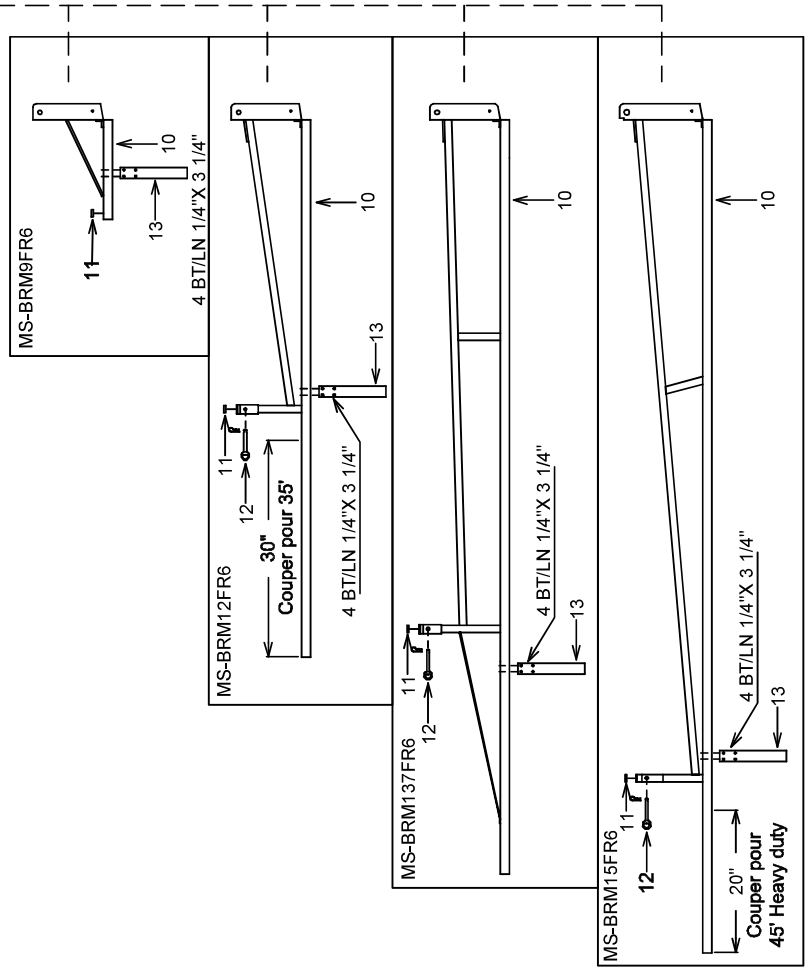
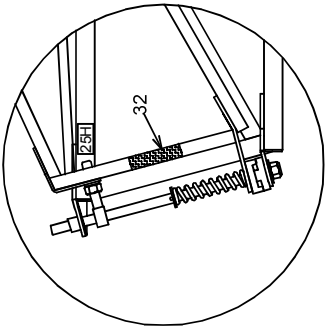
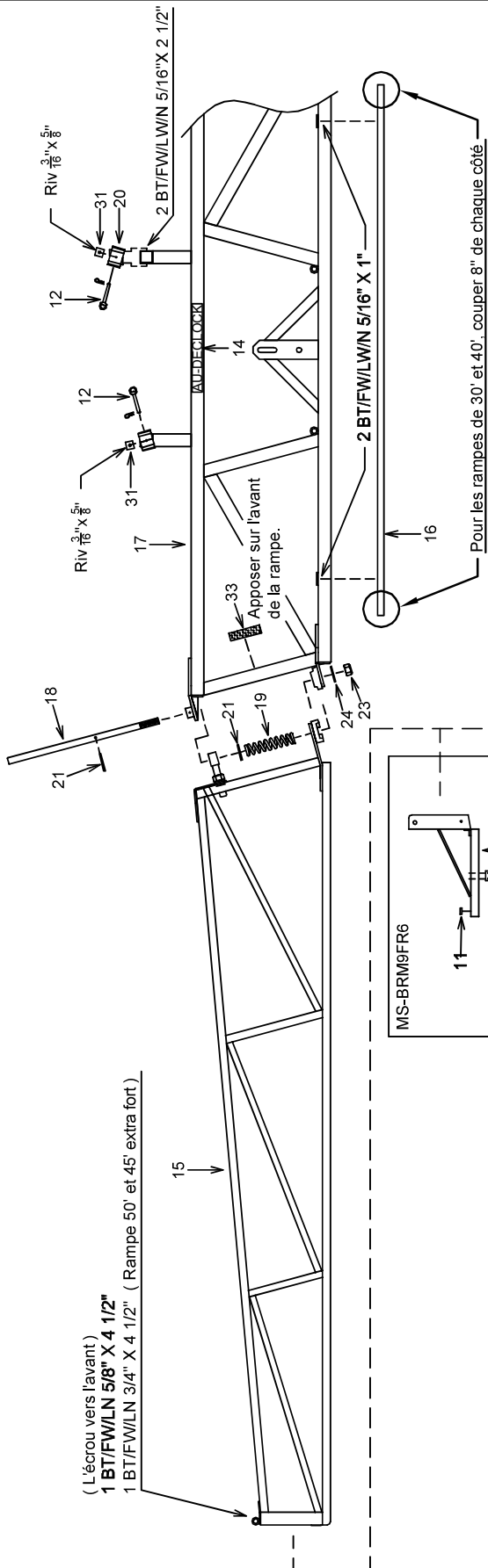

MS PULVÉRISATEUR MS Inc.	
IPULVAGIRAMPESTRUCTUREBRMFR6	
DATE: 2002-09-27	PAR: P.B.
REV: 2010-08-24	PAR: J.T.
#REV: 1	
TITRE: BATI DE RAMPE MANUEL 30',35',40',45',50'.	
# REC.: MS-BRM9FR6 / MS-BRM15FR6	
MS-BRM12FR6	
MS-BRM137FR6	
APP:	



MS Gregson Inc.

4300 rue Vachon, Drummondville QC J2B 6V4, Canada
Tél.: 819 474-1910 • Fax : 819 474-5317 • orders@msgregson.com

BOM

MS-BRM137FR6

REVISION

0

Desc. Française Bâti de rampe manuel 45', sans plomberie
English Desc. 45' manual boom frame without plumbing

Réf.	Quantité	Produit	Description française	English Description
10	2.00	MS-BE6J453R2	Extension rampe 6 jets 45'	Boom extension 6 noz. / 45'
11	2.00	SN-4055	Bumper rubber	Bumper rubber
12	4.00	AU-HP0612	Goupille 3/8" x 3" longueur utilisable	Pin 3/8" x 3"
13	2.00	MS-PAEXT01	Un patin d'ext./ r8.5f	One ext. skate /r8.5f
14	2.00	AU-DECLOCK	Autocollant " barrer extension"	Decal " lock extension"
15	2.00	MS-BR8BR3	Bâti 1ere extension 30-45'	1st extension frame 30-45'boom
16	1.00	MS-BR8DR3	Dalle de centre rampe 30-45'	Jet support center 30-45'boom
17	1.00	MS-BR8AR3	Bâti centre rampe 30-45'	Central boom frame 30-45'
18	2.00	MS-FR0027	Gond 3/4" x 24 7/8", filet et trou	Threaded and drilled 3/4" x 24 7/8" hinge
19	2.00	MS-F42790	Ressort 6" x 1 3/4" x 3/8"	6" x 1 3/4" x 3/8" spring
20	1.00	MS-BR8GR3	Attache fermeture rampe 30-45'	Boom closing attach. 30-45'
22	2.00	BT-FW34SP	Rondelle plate 3/4" ID, 2" OD	Flat washer 3/4"
23	2.00	BT-LN34	Écrou freiné nylon 3/4 unc	Locknut nylon 3/4 unc
29	2.00	BT-FW34	Rondelle plate 3/4"	Flat washer 3/4"
30	2.00	AU-DECGR25H	Autocollant graisser au 25 hres 1" x 2"	Decal "grease every 25h"
31	2.00	MS-BRH15S	Plaque de h.m.w. / fermeture	H.m.w. plate / boom closing
32	2.00	MS-AC2X3R	Autocollant bande réfléchissante rouge 2" x 3"	Red sticker 2" x 3"
33	2.00	MS-AC2X3J	Autocollant bande réfléchissante jaune 1" x 3"	Yellow sticker 1"x 3"

Desc. Française Bâti de rampe h yd. 50', HV
 English Desc. 50' hv frame h yd. boom

Réf.	Quantité	Produit	Description française	English Description
1	1.00	AR520-HV050B	Interface, trapeze, Rampe HV050 / HV060 avec glissière	Interface, trapeze, HV050 / HV060 Boom with slider
2	2.00	SN-RB115	Bumper rubber 5/8" x 1 1/2"	Rubber bumper 5/8" x 1 1/2"
3	2.00	MO-DD119509	Clip cable acier 3/8	Clip/steel cable 3/8
5	2.00	MS-F95715	Ressort 22" x 2" x 3/8"	22" x 2" x 3/8" spring
6	2.00	MS-BRH15L	Attache de tige filetée rh15m	Fastenning bushing / rod rh15m
7	6.00	BT-LN34	Écrou freiné nylon 3/4 unc	Locknut nylon 3/4 unc
9	2.00	MS-TF34578	Tige filete 3/4 nc 5 7/8" long	Threaded shaft 3/4 nc 5 7/8".
10	2.00	MS-BRH15F	Pivot 1ere extension rh15m	1st extension pin rh15m
11	2.00	MS-CA0003	Cable assemblé 3/8" x 157"	3/8" x 157" cable assembly
12	1.00	MS-BRH15A4	Centre rampe hyd. m-s 15m.	M-s hyd. boom center 50'
13	2.00	MS-BRH15CH28	Chaine retenue 28"/ressort r.v	Restraining chaine 28"
15	2.00	MS-BRH15B4R2	Bâti 1ere ext. rampe hyd. 50'	1st extention 15m hyd boom
16	2.00	MS-FR0033	Poulie 3" x 1 3/8" droite	3" x 1 3/8" straight pulley
17	2.00	MS-FR0034	Poulie 3" x 1 3/8", rainuré	3" x 1 3/8" grooved pulley
18	6.00	AU-DECGR25H	Autocollant graisser au 25 hres 1" x 2"	Decal "grease every 25h"
19	4.00	MS-BRH18Z	Plaque de h.m.w./stabilisation	Stabilisation plate (h.m.w.)
20	2.00	MS-BRH15V	Support derniere ext r50-60v	Last ext.support r50-60v
21	3.00	MO-HSR6610400	Orifice 3/8"mnpt x 3/8"pfnpt. perce à 0.0400", ID noir	Restrictor 3/8x3/8 drill .0520" black mark
22	4.00	AU-ISN1064	Raccord droit 3/8"mnpt x 1/4"hb céd.80 pl	Straight fitt. 3/8"mnpt x 1/4"hb ced.80 pl
23	146.00	FH-H14	Boyau hydraulique 1/4", 1pli, 3000 lbs/po2	Hyd. hose 1/4", 1 ply, 3000 psi
24	2.00	MI-645760R2	Cylindre 2 1/2" x 16" x 1 1/8" nt, 3/4-16 forb	Cylinder 2 1/2"x 16" x 1 1/8" nt, 3/4-16 f orb
26	4.00	MO-80104	Qc à bille fermé hyd. mâle 1/2" x 1/2"fnpt pl***	Close ball coupler male 1/2" x 1/2"fnpt pl***
27	2.00	MS-BRHV50FJ	Fixation de bar de porte buse	Nozzles support brace
28	1.00	MS-BRHV50BJ	Barre support de porte buse 1 1/2" x 115"	Nozzle supporting bar 1 1/2" x 115"
29	2.00	MS-F42790	Ressort 6" x 1 3/4" x 3/8"	6" x 1 3/4" x 3/8" spring
31	2.00	MS-BRH15C3	Bâti 1ere part. 2e ext. rampe hyd. 50'	1st part 2nd ext. 50'hyd. boom
32	2.00	MS-FR0017	Gond 3/4" x 15 1/2", filet	Threaded 3/4" x 15 1/2" hinge
33	2.00	MS-BRH15E5	2e part. 2e ext. r. verticale	2nd part 2nd ext. verti. boom
34	2.00	MS-PAEXT03	Patin d'ext. rampe hyd.	Hyd. boom ext. skate
35	4.00	MS-BRHV18H	Bague 1" x 5/8" x 3"	1" x 5/8" x 3" Bushing
36	2.00	MS-BRH18D	Emprise de stabilisation r18m	Stabilisation attachement r18m
37	8.00	AU-IS4SCF	Ferrule 1/4" céd.80 pl.	Ferrule 1/4" ced.80 pl.
38	4.00	AU-ISN1084	Raccord droit 1/2"mnpt x 1/4"hb céd.80 pl	Straight fitt. 1/2"mnpt x 1/4"hb ced.80 pl
41	2.00	MS-BRH15R	Bague 1" x 0.625" x 1 3/8"	1" x 0.625" x 1 3/8" Bushing
42	4.00	MS-FC0003	Attache 1 3/8" c x 3 1/8"	1 3/8" c x 3 1/8" cable tie
44	2.00	MS-CA0005	Cable assemblé 3/8" x 65"	3/8" x 65" cable assembly
47	2.00	BT-FW34	Rondelle plate 3/4"	Flat washer 3/4"
48	1.00	AU-S1022C	Mamelon court 3/8"mnpt x 3/8"mnpt céd.80 pl	Close nipple 3/8"mnpt x 3/8"mnpt ced.80 pl
49	4.00	MO-951586	Adapt. coudé 3/4-16morb x 3/8"pfnpt céd.80 pl	Elbow adapt. 3/4-16morb x 3/8"pfnpt ced.80 pl
50	1.00	CA-FT03NPT	Vanne à aiguille 2v 3/8"fnpt, plaqué	Needle valve 2v 3/8"fnpt, plated
51	2.00	MS-AC2X3R	Autocollant bande réfléchissante rouge 2" x 3"	Red sticker 2" x 3"
52	2.00	MS-AC2X3J	Autocollant bande réfléchissante jaune 1" x 3"	Yellow sticker 1"x 3"

Desc. Française Bâti de rampe h yd. 60', HV
 English Desc. 60' hv frame h yd. boom

Réf.	Quantité	Produit	Description française	English Description
1	1.00	AR520-HV050B	Interface, trapeze, Rampe HV050 / HV060 avec glissière	Interface, trapeze, HV050 / HV060 Boom with slider
2	2.00	SN-RB115	Bumper rubber 5/8" x 1 1/2"	Rubber bumper 5/8" x 1 1/2"
3	2.00	MO-DD119509	Clip cable acier 3/8	Clip/steel cable 3/8
5	2.00	MS-F95715	Ressort 22" x 2" x 3/8"	22" x 2" x 3/8" spring
6	2.00	MS-BRH15L	Attache de tige filetée rh15m	Fastenning bushing / rod rh15m
7	6.00	BT-LN34	Écrou freiné nylon 3/4 unc	Locknut nylon 3/4 unc
9	2.00	MS-TF34578	Tige filete 3/4 nc 5 7/8" long	Threaded shaft 3/4 nc 5 7/8".
10	2.00	MS-BRH15F	Pivot 1ere extension rh15m	1st extension pin rh15m
11	2.00	MS-CA0004	Cable assemblé 3/8" x 175"	3/8" x 175" cable assembly
12	1.00	MS-BRHV18A2R2	Bâti centre rampe 60'	60' Boom center frame
13	4.00	MS-FC0003	Attache 1 3/8" c x 3 1/8"	1 3/8" c x 3 1/8" cable tie
15	2.00	MS-BRHV18B3R2	Bâti 1e ext. rampe hyd. 60'	60' hyd. boom 1st extension
16	2.00	MS-FR0033	Poulie 3" x 1 3/8" droite	3" x 1 3/8" straight pulley
17	2.00	MS-FR0034	Poulie 3" x 1 3/8", rainuré	3" x 1 3/8" grooved pulley
18	7.00	AU-DECGR25H	Autocollant graisser au 25 hres 1" x 2"	Decal "grease every 25h"
19	4.00	MS-BRH18Z	Plaque de h.m.w./stabilisation	Stabilisation plate (h.m.w.)
20	2.00	MS-BRH15V	Support derniere ext r50-60v	Last ext.support r50-60v
21	3.00	MO-HSR6610400	Orifice 3/8"mnpt x 3/8"pfmpt. perce à 0.0400", ID noir	Restrictor 3/8x3/8 drill .0520" black mark
22	4.00	AU-ISN1064	Raccord droit 3/8"mnpt x 1/4"hb céd.80 pl	Straight fitt. 3/8"mnpt x 1/4"hb ced.80 pl
23	146.00	FH-H14	Boyau hydraulique 1/4", 1pli, 3000 lbs/po2	Hyd. hose 1/4", 1 ply, 3000 psi
24	2.00	MI-645298R2	Cylindre 2 1/2" x 20" x 1 1/8" nt, 3/4-16 forb.PSP seal ***	Cylinder 2 1/2" x 20" x 1 1/8" nt, 3/4-16 f orb.PSP seal
26	4.00	MO-80104	Qc à bille fermé hyd. mâle 1/2" x 1/2"fnpt pl***	Close ball coupler male 1/2" x 1/2"fnpt pl***
27	1.00	MS-BRHV60BJ	Barre support de porte buse 1 1/2" x 144"	Nozzle supporting bar
28	2.00	MS-BRHV50FJ	Fixation de bar de porte buse	Nozzles support brace
29	2.00	MS-F42790	Ressort 6" x 1 3/4" x 3/8"	6" x 1 3/4" x 3/8" spring
30	2.00	MS-BRHV18CH29	Chaine retenue 29"/ressort r.v	Restraining chaine 29"
31	2.00	MS-BRHV18C3	1e partie 2e ext. 60' vertical	1st part 2nd ext. 60' vertical
32	2.00	MS-FR0017	Gond 3/4" x 15 1/2", filet	Threaded 3/4" x 15 1/2" hinge
33	2.00	MS-BRH15E5	2e part. 2e ext. r. verticale	2nd part 2nd ext. verti. boom
34	2.00	MS-PAEXT03	Patin d'ext. rampe hyd.	Hyd. boom ext. skate
35	4.00	MS-BRHV18H	Bague 1" x 5/8" x 3"	1" x 5/8" x 3" Bushing
36	2.00	MS-BRH18D	Emprise de stabilisation r18m	Stabilisation attachment r18m
37	8.00	AU-IS4SCF	Ferrule 1/4" céd.80 pl.	Ferrule 1/4" ced.80 pl.
38	4.00	AU-ISN1084	Raccord droit 1/2"mnpt x 1/4"hb céd.80 pl	Straight fitt. 1/2"mnpt x 1/4"hb ced.80 pl
40	2.00	MS-BRH15S	Plaque de h.m.w. / fermeture	H.m.w. plate / boom closing
41	2.00	MS-BRH15R	Bague 1" x 0.625" x 1 3/8"	1" x 0.625" x 1 3/8" Bushing
44	2.00	MS-CA0007	Cable assemblé 3/8" x 80"	3/8" x 80" cable assembly
47	2.00	BT-FW34	Rondelle plate 3/4"	Flat washer 3/4"
48	1.00	AU-S1022C	Mamelon court 3/8"mnpt x 3/8"mnpt céd.80 pl	Close nipple 3/8"mnpt x 3/8"mnpt ced.80 pl
49	4.00	MO-951586	Adapt. coudé 3/4-16morb x 3/8"pfmpt céd.80 pl	Elbow adapt. 3/4-16morb x 3/8"pfmpt ced.80 pl
50	1.00	CA-FT03NPT	Vanne à aiguille 2v 3/8"fnpt, plaqué	Needle valve 2v 3/8"fnpt, plated
51	2.00	MS-AC2X3J	Autocollant bande réfléchissante jaune 1" x 3"	Yellow sticker 1"x 3"
52	2.00	MS-AC2X3R	Autocollant bande réfléchissante rouge 2" x 3"	Red sticker 2" x 3"

Plomb. 3 et 5 sect., 27 buses aux 20" pour RF13.7
 Water plumb. 3 and 5 sect., 27 nozzles at 20" for RF137

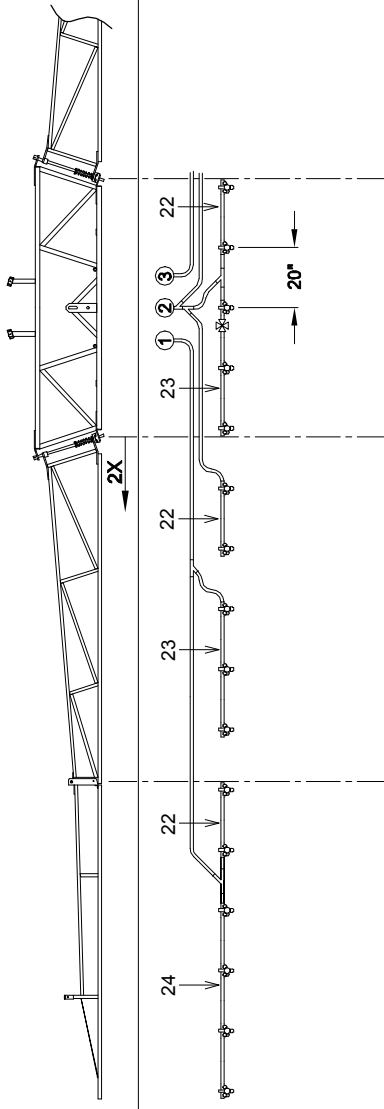

RE-PE3R137FR1
 3 Sections
 27: (9-9-9)

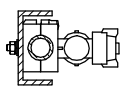

<p>Légende Legend</p>	<p>Support de jet (déporté) Nozzle support (offset)</p>	<p>No. de section de rampe Boom section number</p> <p>Exemple de montage d'un support de jet. Nozzle holder assembly exemple.</p> <p>Jets multiples Multiple nozzles</p> <p>Jets simple Single nozzles</p> <p>Bâti de rampe Boom frame</p>	<p>Parts List:</p> <ul style="list-style-type: none"> AU-BOYAU4MM MP-466350070 Trou Ø3/8" Hole Ø3/8" 4mm 1/8" AU-BOYAU18 JB-21736NY 	<p>MS</p> <p>PULVÉRISATEUR MS Inc. MS SPRAYER Inc.</p> <p>PULVAGIRAMPEPLOMB-EAUPER137FR1</p> <p>DATE: 2004-10-13 PAR/By: E.L.</p> <p>REV: 2004-10-13 PAR/By: E.L. #REV: 0</p> <p># REC.: RE-PE3R137FR1</p> <p>APP: </p>
----------------------------------	--	---	---	--



MS Gregson Inc.

4300 rue Vachon, Drummondville QC J2B 6V4, Canada
Tél.: 819 474-1910 • Fax : 819 474-5317 • orders@msgregson.com

BOM

RE-PE3R137FR1

REVISION

1

Desc. Française Plomb. eau 3 sect., 45' MA 27 buses aux 20"

English Desc. 3 sect. water plumb., 45' MA 27 noz. at 20"

Réf.	Quantité	Produit	Description française	English Description
1	34.00	DA-SHAS12	Collier de serrage en acier inox. 9/16" x 1 1/4"	Stainless steel collar 9/16" x 1 1/4"
2	110.00	LV-342N	Boyau noir, 3/4", 150 lb/po2, caoutchouc 1 pli	Black hose 3/4", 1 ply, 150 psi
4	10.00	MP-402909	Bouchon 1/4 tour avec gasket	Black cap plug / gasket
4	10.00	AU-8294022	Adaptateur 3/4"fbsp x capuchon vissé mâle	Adapt.3/4"fbsp x male twist cap
5	7.00	AU-Y34	Raccord-union en Y 3/4"hb poly.bleu	Poly.y-3/4" hb,bleu
6	10.00	JB-IMB0606FNY	Adapt. droit 3/4"fnpt x 3/4"hb céd.80 ny.	Straight adapt. 3/4"fnpt x 3/4"hb ced.80 ny.
11	27.00	JB-QJ1756034	Support de buse simple 3/4"	Nylon jet support 3/4"
22	5.00	MS-TU220	Tube poly. 3/4" x 22 1/2", 2 trous 20"	Poly. tube 3/4" x 24", 2 holes 20"
23	3.00	MS-TU320	Tube poly. 3/4" x 42 1/2", 3 trous 20"	Poly. tube 3/4" x 42 1/2", 3 holes 20"
24	2.00	MS-TU420	Tube poly. 3/4" x 62 1/2", 4 trous 20"	Poly. tube 3/4" x 64", 4 holes 20"



MS Gregson Inc.
 4300 rue Vachon, Drummondville QC J2B 6V4, Canada
 Tél.: 819 474-1910 • Fax : 819 474-5317 • orders@msgregson.com

BOM	RE-PE3R137FTQ
REVISION	1

Desc. Française	Plomb. eau 3 sect., 45' MA 27 buses mult. 20"
English Desc.	3 sect. water plumb., 45' MA 27 mult. noz. at 20"

Réf.	Quantité	Produit	Description française	English Description
11	27.00	JB-QJ36334NYB	Support de buse triple pour tuyau 3/4"	Triple nozzle body for 3/4" pipe

Plomb. 3 et 5 sect., 27 buses aux 20" pour rampe HV45
 Water plumb. 3 and 5 sect., 27 nozzles at 20" for 45'HV

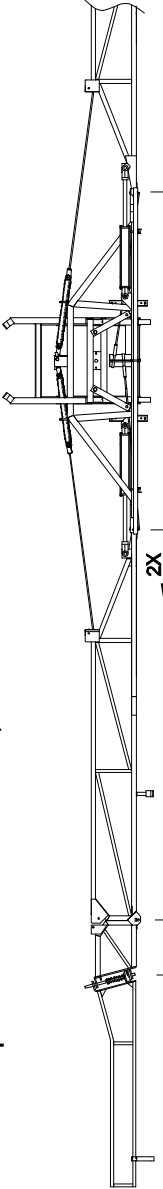

RE-PE3R45V8
 3 Sections
 27: (9-9-9)

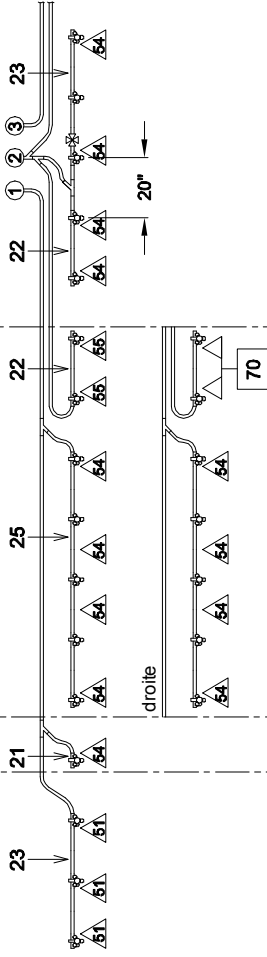

RE-PE5R45V8
 5 Sections
 27: (4-7-5-7-4)

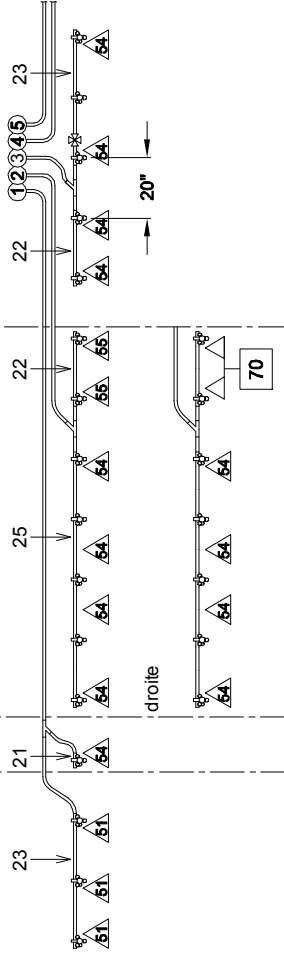

<p>Légende Legend</p>	<p>Support de jet (déporté) Nozzle support (offset)</p>	<p>No. de section de rampe Boom section number</p> <p>Lecture de pression Pressure reading</p> <p>Détails Details</p> <p>Exemple de montage d'un support de jet. Nozzle holder assembly exemplaire.</p> <p>Jets multiples Multiples nozzles</p> <p>Jets simple Single nozzles</p> <p>Bâti de rampe Boom frame</p>	<p>AU-BOYAU4MM MP-466350070</p> <p>4mm 1/8"</p> <p>AU-BOYAU18 JB-21736NY</p> <p>Trou Ø3/8" Hole Ø3/8"</p> <p>31</p> <p>33</p>	<p>PULVÉRISATEUR MS Inc. MS SPRAYER Inc.</p> <p>PULVAGIRAMPEPLOMB-EAUPER45V8</p> <p>DATE: 2004-10-12</p> <p>REV: 2004-10-12</p> <p># REC.: RE-PE3R45V8</p> <p>RE-PE5R45V8</p> <p>APP: </p>
---	---	---	--	---

Desc. Française Plomb. eau 3 sect., 45' HV 27 buses aux 20"

English Desc. 3 sect. water plumb., 45' HV 27 noz. at 20"

Réf.	Quantité	Produit	Description française	English Description
1	34.00	DA-SHAS12	Collier de serrage en acier inox. 9/16" x 1 1/4"	Stainless steel collar 9/16" x 1 1/4"
2	120.00	LV-342N	Boyau noir, 3/4", 150 lb/po2, caoutchouc 1 pli	Black hose 3/4", 1 ply, 150 psi
4	10.00	MP-402909	Bouchon 1/4 tour avec gasket	Black cap plug / gasket
4	10.00	AU-8294022	Adaptateur 3/4"fbsp x capuchon vissé mâle	Adapt.3/4"fbsp x male twist cap
5	7.00	AU-Y34	Raccord-union en Y 3/4"hb poly.bleu	Poly.y-3/4" hb,bleu
6	10.00	JB-IMB0606FNY	Adapt. droit 3/4"fnpt x 3/4"hb céd.80 ny.	Straight adapt. 3/4"fnpt x 3/4"hb ced.80 ny.
11	27.00	JB-QJ1756034	Support de buse simple 3/4"	Nylon jet support 3/4"
12	24.00	AU-3254PP	Support de tuyau (la paire) 3/4", 1"od. poly noir	Poly.clamp 3/4", 1"t (pair) Black
21	2.00	MS-TU1	Tube poly. 3/4" x 5 1/4", 1 trou	Poly tube 3/4" x 6", 1 hole
22	3.00	MS-TU220	Tube poly. 3/4" x 22 1/2", 2 trous 20"	Poly. tube 3/4" x 24", 2 holes 20"
23	3.00	MS-TU320	Tube poly. 3/4" x 42 1/2", 3 trous 20"	Poly. tube 3/4" x 42 1/2", 3 holes 20"
25	2.00	MS-TU520	Tube poly. 3/4" x 82 1/2", 5 trous 20"	Poly. tube 3/4" x 84", 5 holes 20"
51	6.00	BT-14212	Boulon 1/4 x 2 1/2" nc plaqué	Bolt 1/4 x 2 1/2" nc plated
51	6.00	BT-FW14	Rondelle plate 1/4"	Flat washer 1/4"
51	6.00	BT-LN14	Écrou freiné nylon 1/4 unc	Nylon 1/4" lock nut unc
51	6.00	MS-SJT151	Sup. jet tube 1 1/2" x 1"	Jet support for 1.5" x 1" tube
51	6.00	BT-FW14	Rondelle plate 1/4"	Flat washer 1/4"
54	14.00	MS-SJT15C	Sup. jet tube 1 1/2" x 1 1/2"	Jet support for 1 1/2" squ. tu.
54	14.00	BT-14212	Boulon 1/4 x 2 1/2" nc plaqué	Bolt 1/4 x 2 1/2" nc plated
54	14.00	BT-FW14	Rondelle plate 1/4"	Flat washer 1/4"
54	14.00	BT-FW14	Rondelle plate 1/4"	Flat washer 1/4"
54	14.00	BT-LN14	Écrou freiné nylon 1/4 unc	Nylon 1/4" lock nut unc
55	2.00	BT-LN14	Écrou freiné nylon 1/4 unc	Nylon 1/4" lock nut unc
55	2.00	MS-SJT15CL	Sup. jet tube long 1 1/2" x 1 1/2"	Long jet sup. for 1.5" squa.tu
55	2.00	BT-FW14	Rondelle plate 1/4"	Flat washer 1/4"
55	2.00	BT-14212	Boulon 1/4 x 2 1/2" nc plaqué	Bolt 1/4 x 2 1/2" nc plated
55	2.00	BT-FW14	Rondelle plate 1/4"	Flat washer 1/4"
70	2.00	MS-SBECRA	Support sur rampe pour porte buse	Boom bracket for nozzle bodies
70	1.00	MS-SBEE	Support boyau elargie extension	Boom extension bracket
70	1.00	AU-UB38112212	Boulon en U, carré 3/8 x 1 1/2 x 2 1/2	Sq u-bolt 3/8 x 1 1/2 x 2 1/2
70	1.00	BT-LN38	Écrou freiné nylon 3/8 unc	Locknut nylon 3/8 unc

Desc. Française Plomb. eau 5 sect., 45' HV 27 buses aux 20"

English Desc. 5 sect. water plumb., 45' HV 27 noz. at 20"

Réf.	Quantité	Produit	Description française	English Description
1	30.00	DA-SHAS12	Collier de serrage en acier inox. 9/16" x 1 1/4"	Stainless steel collar 9/16" x 1 1/4"
2	120.00	LV-342N	Boyau noir, 3/4", 150 lb/po2, caoutchouc 1 pli	Black hose 3/4", 1 ply, 150 psi
4	10.00	MP-402909	Bouchon 1/4 tour avec gasket	Black cap plug / gasket
4	10.00	AU-8294022	Adaptateur 3/4"fbsp x capuchon vissé mâle	Adapt.3/4"fbsp x male twist cap
5	5.00	AU-Y34	Raccord-union en Y 3/4"hb poly.bleu	Poly.y-3/4" hb,bleu
6	10.00	JB-IMB0606FNY	Adapt. droit 3/4"fnpt x 3/4"hb céd.80 ny.	Straight adapt. 3/4"fnpt x 3/4"hb ced.80 ny.
11	27.00	JB-QJ1756034	Support de buse simple 3/4"	Nylon jet support 3/4"
12	24.00	AU-3254PP	Support de tuyau (la paire) 3/4", 1"od. poly noir	Poly.clamp 3/4", 1"t (pair) Black
21	2.00	MS-TU1	Tube poly. 3/4" x 5 1/4", 1 trou	Poly tube 3/4" x 6", 1 hole
22	3.00	MS-TU220	Tube poly. 3/4" x 22 1/2", 2 trous 20"	Poly. tube 3/4" x 24", 2 holes 20"
23	3.00	MS-TU320	Tube poly. 3/4" x 42 1/2", 3 trous 20"	Poly. tube 3/4" x 42 1/2", 3 holes 20"
25	2.00	MS-TU520	Tube poly. 3/4" x 82 1/2", 5 trous 20"	Poly. tube 3/4" x 84", 5 holes 20"
51	6.00	BT-14212	Boulon 1/4 x 2 1/2" nc plaqué	Bolt 1/4 x 2 1/2" nc plated
51	6.00	BT-FW14	Rondelle plate 1/4"	Flat washer 1/4"
51	6.00	BT-LN14	Écrou freiné nylon 1/4 unc	Nylon 1/4" lock nut unc
51	6.00	MS-SJT151	Sup. jet tube 1 1/2" x 1"	Jet support for 1.5" x 1" tube
51	6.00	BT-FW14	Rondelle plate 1/4"	Flat washer 1/4"
54	14.00	MS-SJT15C	Sup. jet tube 1 1/2" x 1 1/2"	Jet support for 1 1/2" squ. tu.
54	14.00	BT-14212	Boulon 1/4 x 2 1/2" nc plaqué	Bolt 1/4 x 2 1/2" nc plated
54	14.00	BT-FW14	Rondelle plate 1/4"	Flat washer 1/4"
54	14.00	BT-FW14	Rondelle plate 1/4"	Flat washer 1/4"
54	14.00	BT-LN14	Écrou freiné nylon 1/4 unc	Nylon 1/4" lock nut unc
55	2.00	BT-LN14	Écrou freiné nylon 1/4 unc	Nylon 1/4" lock nut unc
55	2.00	MS-SJT15CL	Sup. jet tube long 1 1/2" x 1 1/2"	Long jet sup. for 1.5" squa.tu
55	2.00	BT-14212	Boulon 1/4 x 2 1/2" nc plaqué	Bolt 1/4 x 2 1/2" nc plated
55	2.00	BT-FW14	Rondelle plate 1/4"	Flat washer 1/4"
55	2.00	BT-FW14	Rondelle plate 1/4"	Flat washer 1/4"
70	2.00	MS-SBECRA	Support sur rampe pour porte buse	Boom bracket for nozzle bodies
70	1.00	MS-SBEE	Support boyau elargie extension	Boom extension bracket
70	1.00	AU-UB38112212	Boulon en U, carré 3/8 x 1 1/2 x 2 1/2	Sq u-bolt 3/8 x 1 1/2 x 2 1/2
70	1.00	BT-LN38	Écrou freiné nylon 3/8 unc	Locknut nylon 3/8 unc

RAMPE 45' HV, PLOMBERIE EAU 3 SECTIONS 45' HV BOOM, WATER PLUMBING 3 SECTION

45' HYDRAULIQUE
VERTICALE.
9-9-8

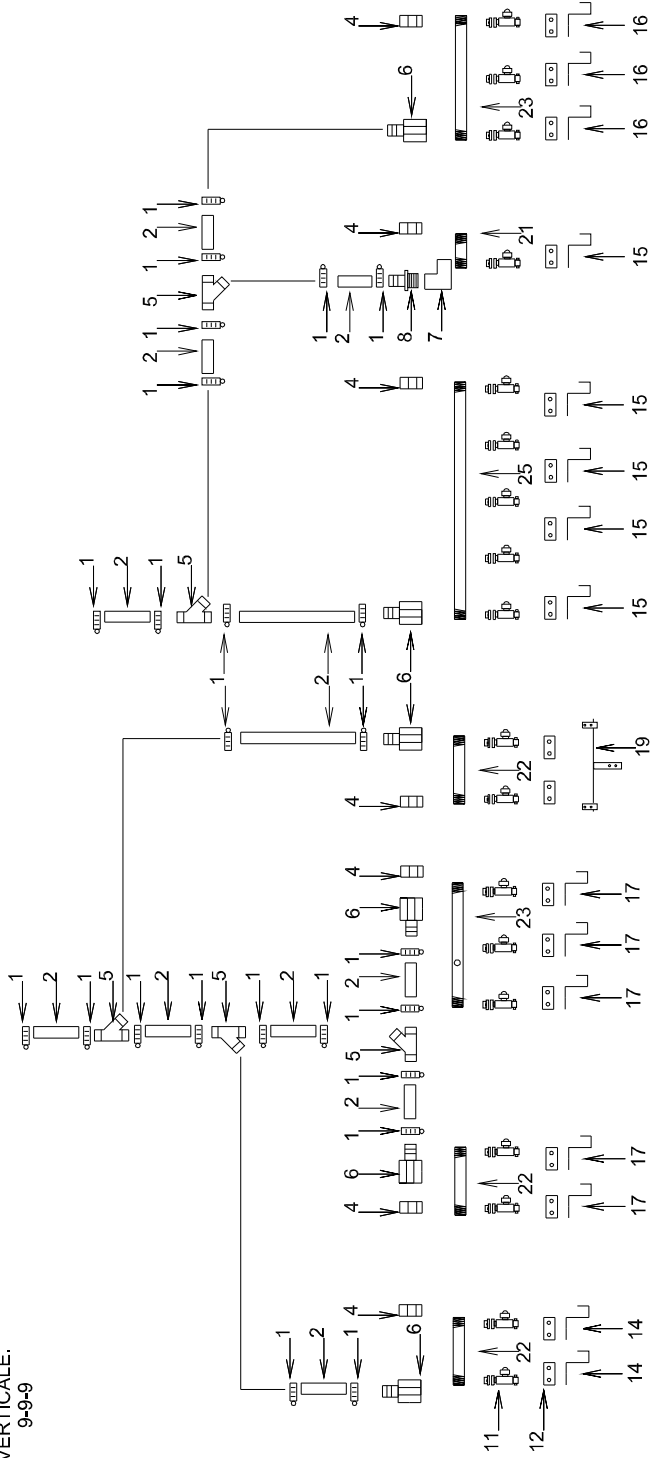

SUPPORTS DE TUBES

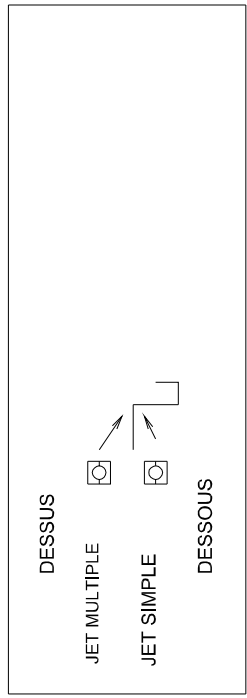

* POUR LECTURE DE PRESSION

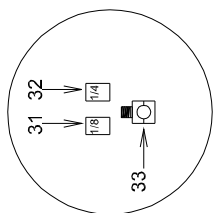

PULVÉRISATEUR MS Inc. MS SPRAYER Inc.
IPULVAGIRAMPEPLOMB-EAU/PE3R45V8
DATE: 1998-09-09 PAR _{By} : G.L.
REV: 2003-01-13 PAR _{By} : P.B. #REV: 3
REC.: RE-PE3R45V8
RE-PE3R45QV8
APP:



MS Gregson Inc.

4300 rue Vachon, Drummondville QC J2B 6V4, Canada
Tél.: 819 474-1910 • Fax : 819 474-5317 • orders@msgregson.com

BOM	RE-PE3R45QV8
REVISION	1

Desc. Française Plomb. eau 3 sect., 45' HV 27 buses mult. 20"
 English Desc. 3 sect. water plumb., 45' HV 27 mult. noz. at 20"

Réf.	Quantité	Produit	Description française	English Description
11	27.00	JB-QJ36334NYB	Support de buse triple pour tuyau 3/4"	Triple nozzle body for 3/4" pipe

Plomb. 3 et 5 sect., 30 buses aux 20" pour rampe HV50
 Water plumb. 3 and 5 sect., 30 nozzles at 20" for 50'HV

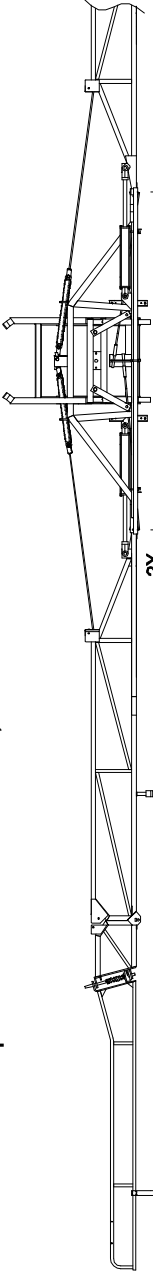

RE-PE3R50V8
 3 Sections
 30: (10-10-10)

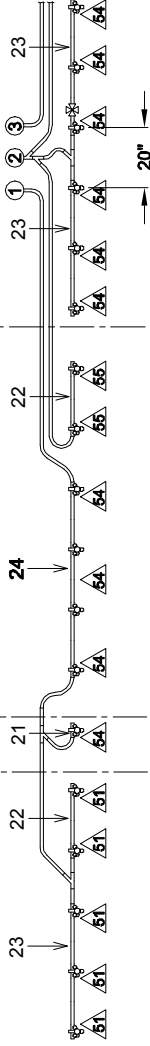

RE-PE5R50V8
 5 Sections
 30: (6-6-6-6-6)

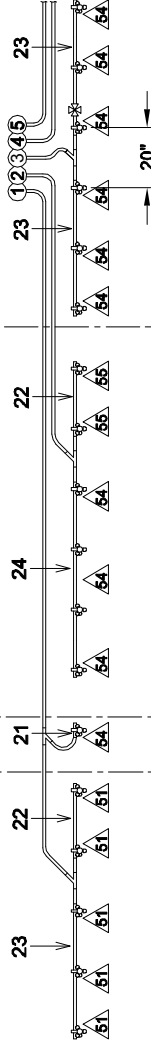

Légende
 Legend

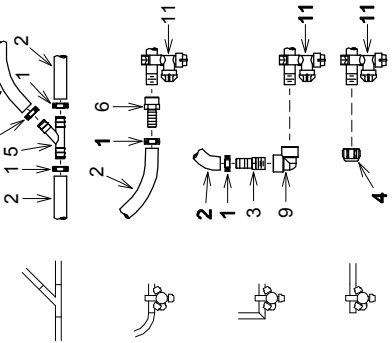

No. de section de rampe
 Boom section number

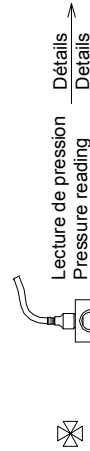

Exemple de montage d'un support de jet.
 Nozzle holder assembly example.



Lecture de pression
 Pressure reading

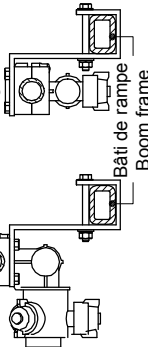

AU-BOYAU4MM
 MP-466350070
 4mm 1/8"
 AU-BOYAU18
 JB-21736NY
 Trou Ø3/8"
 Hole Ø3/8"

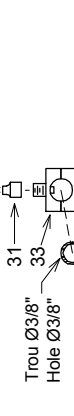

PULVÉRISATEUR MS Inc.
MS SPRAYER Inc.

PULVAGIRAMPEPLOMB-EAUPER50V8
 DATE: 2004-10-12
 REV: 2004-10-18
 # REC.: RE-PE3R50V8
 RE-PE5R50V8

APP:



MS Gregson Inc.

4300 rue Vachon, Drummondville QC J2B 6V4, Canada
Tél.: 819 474-1910 • Fax : 819 474-5317 • orders@msgregson.com

BOM

RE-PE3R50V8

REVISION

4

Desc. Française Plomb. eau 3 sect., 50' HV 30 buses aux 20"

English Desc. 3 sect. water plumb., 50' HV 30 noz. at 20"

Réf.	Quantité	Produit	Description française	English Description
1	38.00	DA-SHAS12	Collier de serrage en acier inox. 9/16" x 1 1/4"	Stainless steel collar 9/16" x 1 1/4"
2	120.00	LV-342N	Boyau noir, 3/4", 150 lb/po2, caoutchouc 1 pli	Black hose 3/4", 1 ply, 150 psi
4	10.00	MP-402909	Bouchon 1/4 tour avec gasket	Black cap plug / gasket
4	10.00	AU-8294022	Adaptateur 3/4"fbsp x capuchon vissé mâle	Adapt.3/4"fbsp x male twist cap
5	7.00	AU-Y34	Raccord-union en Y 3/4"hb poly.bleu	Poly.y-3/4" hb,bleu
6	14.00	JB-IMB0606FNY	Adapt. droit 3/4"fnpt x 3/4"hb céd.80 ny.	Straight adapt. 3/4"fnpt x 3/4"hb ced.80 ny.
11	30.00	JB-QJ1756034	Support de buse simple 3/4"	Nylon jet support 3/4"
12	28.00	AU-3254PP	Support de tuyau (la paire) 3/4", 1"od. poly noir	Poly.clamp 3/4", 1"t (pair) Black
21	2.00	MS-TU1	Tube poly. 3/4" x 5 1/4", 1 trou	Poly tube 3/4" x 6", 1 hole
22	4.00	MS-TU220	Tube poly. 3/4" x 22 1/2", 2 trous 20"	Poly. tube 3/4" x 24", 2 holes 20"
23	4.00	MS-TU320	Tube poly. 3/4" x 42 1/2", 3 trous 20"	Poly. tube 3/4" x 42 1/2", 3 holes 20"
24	2.00	MS-TU420	Tube poly. 3/4" x 62 1/2", 4 trous 20"	Poly. tube 3/4" x 64", 4 holes 20"
51	10.00	BT-LN14	Écrou freiné nylon 1/4 unc	Nylon 1/4" lock nut unc
51	10.00	MS-SJT151	Sup. jet tube 1 1/2" x 1"	Jet support for 1.5" x 1" tube
51	20.00	BT-FW14	Rondelle plate 1/4"	Flat washer 1/4"
51	10.00	BT-14212	Boulon 1/4 x 2 1/2" nc plaqué	Bolt 1/4 x 2 1/2" nc plated
54	28.00	BT-FW14	Rondelle plate 1/4"	Flat washer 1/4"
54	14.00	MS-SJT15C	Sup. jet tube 1 1/2" x 1 1/2"	Jet support for 1 1/2" squ. tu.
54	14.00	BT-14212	Boulon 1/4 x 2 1/2" nc plaqué	Bolt 1/4 x 2 1/2" nc plated
54	14.00	BT-LN14	Écrou freiné nylon 1/4 unc	Nylon 1/4" lock nut unc
55	4.00	BT-14212	Boulon 1/4 x 2 1/2" nc plaqué	Bolt 1/4 x 2 1/2" nc plated
55	4.00	MS-SJT15CL	Sup. jet tube long 1 1/2" x 1 1/2"	Long jet sup. for 1.5" squa.tu
55	8.00	BT-FW14	Rondelle plate 1/4"	Flat washer 1/4"
55	4.00	BT-LN14	Écrou freiné nylon 1/4 unc	Nylon 1/4" lock nut unc

Desc. Française Plomb. eau 5 sect., 50' HV 30 buses aux 20"

English Desc. 5 sect. water plumb., 50' HV 30 noz. at 20"

Réf.	Quantité	Produit	Description française	English Description
1	38.00	DA-SHAS12	Collier de serrage en acier inox. 9/16" x 1 1/4"	Stainless steel collar 9/16" x 1 1/4"
2	120.00	LV-342N	Boyau noir, 3/4", 150 lb/po2, caoutchouc 1 pli	Black hose 3/4", 1 ply, 150 psi
4	12.00	MP-402909	Bouchon 1/4 tour avec gasket	Black cap plug / gasket
4	12.00	AU-8294022	Adaptateur 3/4"fbsp x capuchon vissé mâle	Adapt.3/4"fbsp x male twist cap
5	7.00	AU-Y34	Raccord-union en Y 3/4"hb poly.bleu	Poly.y-3/4" hb,bleu
6	12.00	JB-IMB0606FNY	Adapt. droit 3/4"fnpt x 3/4"hb céd.80 ny.	Straight adapt. 3/4"fnpt x 3/4"hb ced.80 ny.
11	30.00	JB-QJ1756034	Support de buse simple 3/4"	Nylon jet support 3/4"
12	28.00	AU-3254PP	Support de tuyau (la paire) 3/4", 1"od. poly noir	Poly.clamp 3/4", 1"t (pair) Black
21	2.00	MS-TU1	Tube poly. 3/4" x 5 1/4", 1 trou	Poly tube 3/4" x 6", 1 hole
22	4.00	MS-TU220	Tube poly. 3/4" x 22 1/2", 2 trous 20"	Poly. tube 3/4" x 24", 2 holes 20"
23	4.00	MS-TU320	Tube poly. 3/4" x 42 1/2", 3 trous 20"	Poly. tube 3/4" x 42 1/2", 3 holes 20"
24	2.00	MS-TU420	Tube poly. 3/4" x 62 1/2", 4 trous 20"	Poly. tube 3/4" x 64", 4 holes 20"
51	10.00	MS-SJT151	Sup. jet tube 1 1/2" x 1"	Jet support for 1.5" x 1" tube
51	10.00	BT-FW14	Rondelle plate 1/4"	Flat washer 1/4"
51	10.00	BT-14212	Boulon 1/4 x 2 1/2" nc plaqué	Bolt 1/4 x 2 1/2" nc plated
51	10.00	BT-FW14	Rondelle plate 1/4"	Flat washer 1/4"
51	10.00	BT-LN14	Écrou freiné nylon 1/4 unc	Nylon 1/4" lock nut unc
54	14.00	MS-SJT15C	Sup. jet tube 1 1/2" x 1 1/2"	Jet support for 1 1/2" squ. tu.
54	14.00	BT-14212	Boulon 1/4 x 2 1/2" nc plaqué	Bolt 1/4 x 2 1/2" nc plated
54	14.00	BT-FW14	Rondelle plate 1/4"	Flat washer 1/4"
54	14.00	BT-LN14	Écrou freiné nylon 1/4 unc	Nylon 1/4" lock nut unc
54	14.00	BT-FW14	Rondelle plate 1/4"	Flat washer 1/4"
55	4.00	MS-SJT15CL	Sup. jet tube long 1 1/2" x 1 1/2"	Long jet sup. for 1.5" squa.tu
55	4.00	BT-14212	Boulon 1/4 x 2 1/2" nc plaqué	Bolt 1/4 x 2 1/2" nc plated
55	4.00	BT-FW14	Rondelle plate 1/4"	Flat washer 1/4"
55	4.00	BT-FW14	Rondelle plate 1/4"	Flat washer 1/4"
55	4.00	BT-LN14	Écrou freiné nylon 1/4 unc	Nylon 1/4" lock nut unc



MS Gregson Inc.

4300 rue Vachon, Drummondville QC J2B 6V4, Canada
Tél.: 819 474-1910 • Fax : 819 474-5317 • orders@msgregson.com

BOM	RE-PE3R50QV8
REVISION	1

Desc. Française Plomb. eau 3 sect., 50' HV 30 buses mult. 20"
 English Desc. 3 sect. water plumb., 50' HV 30 mult. noz. at 20"

Réf.	Quantité	Produit	Description française	English Description
11	30.00	JB-QJ36334NYB	Support de buse triple pour tuyau 3/4"	Triple nozzle body for 3/4" pipe

Plomb. 3 et 5 sect., 36 buses aux 20" pour rampe HV60
 Water plumb. 3 and 5 sect., 36 nozzles at 20" for 60'HV

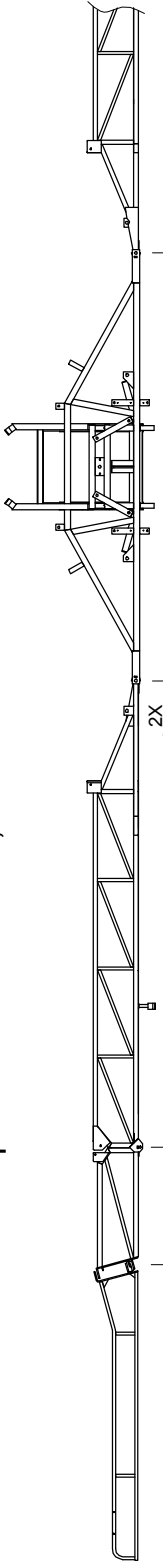

<p>RE-PE3R60V8 3 Sections 36: (12-12-12)</p>	<p>RE-PE5R60V8 5 Sections 36: (7-7-8-7-7)</p>	<p>Partie droite Right side</p>	<p>Partie droite Right side</p>
<p>RE-PE3R60V8 3 Sections 36: (12-12-12)</p>	<p>RE-PE5R60V8 5 Sections 36: (7-7-8-7-7)</p>	<p>Partie droite Right side</p>	<p>Partie droite Right side</p>
<p>Légende Legend</p>	<p>Support de jet (déporté) Nozzle support (offset)</p>	<p>Support de jet (déporté) Nozzle support (offset)</p>	<p>Support de jet (déporté) Nozzle support (offset)</p>
<p>No. de section de rampe Boom section number</p>	<p>Lecture de pression Pressure reading</p>	<p>Jets multiples Multiple nozzles</p>	<p>Jets simple Single nozzles</p>
<p>Exemple de montage d'un support de jet. Nozzle holder assembly exemple.</p>	<p>Exemple de montage d'un support de jet. Nozzle holder assembly exemple.</p>	<p>Exemple de montage d'un support de jet. Nozzle holder assembly exemple.</p>	<p>Exemple de montage d'un support de jet. Nozzle holder assembly exemple.</p>
<p>AU-BOYAU4MM MP-466350070</p>	<p>AU-BOYAU18 MP-466350070</p>	<p>Trou Ø3/8" Hole Ø3/8"</p>	<p>4mm 1/8" AU-BOYAU18 MP-466350070</p>
<p>PULVÉRISATEUR MS Inc. MS SPRAYER Inc.</p> <p>PULVAGIRAMPEPLOMB-EAUPER60V8 DATE: 2004-06-09 PAR: E. L. REV: 2004-10-18 PAR: E. L. #REV: 1 # REC.: RE-PE3R60V8 RE-PE5R60V8</p> <p>APP: </p>			

Desc. Française Plomb. eau 3 sect., 60' HV 36 buses aux 20"

English Desc. 3 sect. water plumb., 60' HV 36 noz. at 20"

Réf.	Quantité	Produit	Description française	English Description
1	38.00	DA-SHAS12	Collier de serrage en acier inox. 9/16" x 1 1/4"	Stainless steel collar 9/16" x 1 1/4"
2	130.00	LV-342N	Boyau noir, 3/4", 150 lb/po2, caoutchouc 1 pli	Black hose 3/4", 1 ply, 150 psi
4	10.00	AU-8294022	Adaptateur 3/4"fbsp x capuchon vissé mâle	Adapt.3/4"fbsp x male twist cap
4	10.00	MP-402909	Bouchon 1/4 tour avec gasket	Black cap plug / gasket
5	7.00	AU-Y34	Raccord-union en Y 3/4"hb poly.bleu	Poly.y-3/4" hb,bleu
6	14.00	JB-IMB0606FNY	Adapt. droit 3/4"fnpt x 3/4"hb céd.80 ny.	Straight adapt. 3/4"fnpt x 3/4"hb ced.80 ny.
11	36.00	JB-QJ1756034	Support de buse simple 3/4"	Nylon jet support 3/4"
12	32.00	AU-3254PP	Support de tuyau (la paire) 3/4", 1"od. poly noir	Poly.clamp 3/4", 1"t (pair) Black
22	6.00	MS-TU220	Tube poly. 3/4" x 22 1/2", 2 trous 20"	Poly. tube 3/4" x 24", 2 holes 20"
23	2.00	MS-TU320	Tube poly. 3/4" x 42 1/2", 3 trous 20"	Poly. tube 3/4" x 42 1/2", 3 holes 20"
24	2.00	MS-TU420	Tube poly. 3/4" x 62 1/2", 4 trous 20"	Poly. tube 3/4" x 64", 4 holes 20"
25	2.00	MS-TU520	Tube poly. 3/4" x 82 1/2", 5 trous 20"	Poly. tube 3/4" x 84", 5 holes 20"
51	10.00	BT-LN14	Écrou freiné nylon 1/4 unc	Nylon 1/4" lock nut unc
51	10.00	BT-14212	Boulon 1/4 x 2 1/2" nc plaqué	Bolt 1/4 x 2 1/2" nc plated
51	10.00	BT-FW14	Rondelle plate 1/4"	Flat washer 1/4"
51	10.00	MS-SJT151	Sup. jet tube 1 1/2" x 1"	Jet support for 1.5" x 1" tube
51	10.00	BT-FW14	Rondelle plate 1/4"	Flat washer 1/4"
54	18.00	MS-SJT15C	Sup. jet tube 1 1/2" x 1 1/2"	Jet support for 1 1/2" squ. tu.
54	18.00	BT-14212	Boulon 1/4 x 2 1/2" nc plaqué	Bolt 1/4 x 2 1/2" nc plated
54	18.00	BT-FW14	Rondelle plate 1/4"	Flat washer 1/4"
54	18.00	BT-FW14	Rondelle plate 1/4"	Flat washer 1/4"
54	18.00	BT-LN14	Écrou freiné nylon 1/4 unc	Nylon 1/4" lock nut unc
55	2.00	MS-SJT15CL	Sup. jet tube long 1 1/2" x 1 1/2"	Long jet sup. for 1.5" squa.tu
55	2.00	BT-14212	Boulon 1/4 x 2 1/2" nc plaqué	Bolt 1/4 x 2 1/2" nc plated
55	2.00	BT-FW14	Rondelle plate 1/4"	Flat washer 1/4"
55	2.00	BT-FW14	Rondelle plate 1/4"	Flat washer 1/4"
55	2.00	BT-LN14	Écrou freiné nylon 1/4 unc	Nylon 1/4" lock nut unc
70	1.00	AU-UB14112214	Boulon en U, carré 1/4 x 1 1/2 x 2 1/4	Sq u-bolt 1/4 x 1 1/2
70	1.00	MS-SBEE	Support boyau elargie extension	Boom extension bracket
70	2.00	MS-SBECRA	Support sur rampe pour porte buse	Boom bracket for nozzle bodies
70	2.00	BT-FW14	Rondelle plate 1/4"	Flat washer 1/4"
70	2.00	BT-LN14	Écrou freiné nylon 1/4 unc	Nylon 1/4" lock nut unc
70	2.00	BT-1434	Boulon 1/4 x 3/4" nc	Bolt 1/4 x 3/4" nc
70	2.00	BT-LN14	Écrou freiné nylon 1/4 unc	Nylon 1/4" lock nut unc

Desc. Française Plomb. eau 5 sect., 60' HV 36 buses aux 20"

English Desc. 5 sect. water plumb., 60' HV 36 noz. at 20"

Réf.	Quantité	Produit	Description française	English Description
1	38.00	DA-SHAS12	Collier de serrage en acier inox. 9/16" x 1 1/4"	Stainless steel collar 9/16" x 1 1/4"
2	173.00	LV-342N	Boyau noir, 3/4", 150 lb/po2, caoutchouc 1 pli	Black hose 3/4", 1 ply, 150 psi
4	12.00	MP-402909	Bouchon 1/4 tour avec gasket	Black cap plug / gasket
4	12.00	AU-8294022	Adaptateur 3/4"fbsp x capuchon vissé mâle	Adapt.3/4"fbsp x male twist cap
5	7.00	AU-Y34	Raccord-union en Y 3/4"hb poly.bleu	Poly.y-3/4" hb,bleu
6	12.00	JB-IMB0606FNY	Adapt. droit 3/4"fnpt x 3/4"hb céd.80 ny.	Straight adapt. 3/4"fnpt x 3/4"hb ced.80 ny.
11	36.00	JB-QJ1756034	Support de buse simple 3/4"	Nylon jet support 3/4"
12	32.00	AU-3254PP	Support de tuyau (la paire) 3/4", 1"od. poly noir	Poly.clamp 3/4", 1"t (pair) Black
22	6.00	MS-TU220	Tube poly. 3/4" x 22 1/2", 2 trous 20"	Poly. tube 3/4" x 24", 2 holes 20"
23	2.00	MS-TU320	Tube poly. 3/4" x 42 1/2", 3 trous 20"	Poly. tube 3/4" x 42 1/2", 3 holes 20"
24	2.00	MS-TU420	Tube poly. 3/4" x 62 1/2", 4 trous 20"	Poly. tube 3/4" x 64", 4 holes 20"
25	2.00	MS-TU520	Tube poly. 3/4" x 82 1/2", 5 trous 20"	Poly. tube 3/4" x 84", 5 holes 20"
51	10.00	BT-LN14	Écrou freiné nylon 1/4 unc	Nylon 1/4" lock nut unc
51	10.00	BT-14212	Boulon 1/4 x 2 1/2" nc plaqué	Bolt 1/4 x 2 1/2" nc plated
51	10.00	BT-FW14	Rondelle plate 1/4"	Flat washer 1/4"
51	10.00	MS-SJT151	Sup. jet tube 1 1/2" x 1"	Jet support for 1.5" x 1" tube
51	10.00	BT-FW14	Rondelle plate 1/4"	Flat washer 1/4"
54	18.00	MS-SJT15C	Sup. jet tube 1 1/2" x 1 1/2"	Jet support for 1 1/2" squ. tu.
54	18.00	BT-14212	Boulon 1/4 x 2 1/2" nc plaqué	Bolt 1/4 x 2 1/2" nc plated
54	18.00	BT-LN14	Écrou freiné nylon 1/4 unc	Nylon 1/4" lock nut unc
54	18.00	BT-FW14	Rondelle plate 1/4"	Flat washer 1/4"
54	18.00	BT-FW14	Rondelle plate 1/4"	Flat washer 1/4"
55	2.00	BT-14212	Boulon 1/4 x 2 1/2" nc plaqué	Bolt 1/4 x 2 1/2" nc plated
55	2.00	BT-FW14	Rondelle plate 1/4"	Flat washer 1/4"
55	2.00	BT-FW14	Rondelle plate 1/4"	Flat washer 1/4"
55	2.00	BT-LN14	Écrou freiné nylon 1/4 unc	Nylon 1/4" lock nut unc
55	2.00	MS-SJT15CL	Sup. jet tube long 1 1/2" x 1 1/2"	Long jet sup. for 1.5" squa.tu
70	2.00	AU-UB14112214	Boulon en U, carré 1/4 x 1 1/2 x 2 1/4	Sq u-bolt 1/4 x 1 1/2
70	2.00	BT-LN14	Écrou freiné nylon 1/4 unc	Nylon 1/4" lock nut unc
70	2.00	BT-1434	Boulon 1/4 x 3/4" nc	Bolt 1/4 x 3/4" nc
70	2.00	BT-LN14	Écrou freiné nylon 1/4 unc	Nylon 1/4" lock nut unc
70	1.00	MS-SBEE	Support boyau elargie extension	Boom extension bracket
70	2.00	MS-SBECRA	Support sur rampe pour porte buse	Boom bracket for nozzle bodies
70	2.00	BT-FW14	Rondelle plate 1/4"	Flat washer 1/4"



MS Gregson Inc.

4300 rue Vachon, Drummondville QC J2B 6V4, Canada
Tél.: 819 474-1910 • Fax : 819 474-5317 • orders@msgregson.com

BOM	RE-PE3R60QV8
REVISION	1

Desc. Française Plomb. eau 3 sect., 60' HV 36 buses mult. 20"
 English Desc. 3 sect. water plumb., 60' HV 36 mult. noz. at 20"

Réf.	Quantité	Produit	Description française	English Description
11	36.00	JB-QJ36334NYB	Support de buse triple pour tuyau 3/4"	Triple nozzle body for 3/4" pipe

#	Ref.	Q.
1	JB-2267414NYB	1
2	JB-4193APP50	1
3	JB-CP19438EPR	1
4	JB-CP256075NY	1
5	JB-OC16	1
6	MP-S301250PP	1
7	JB-RB3414NY40	1

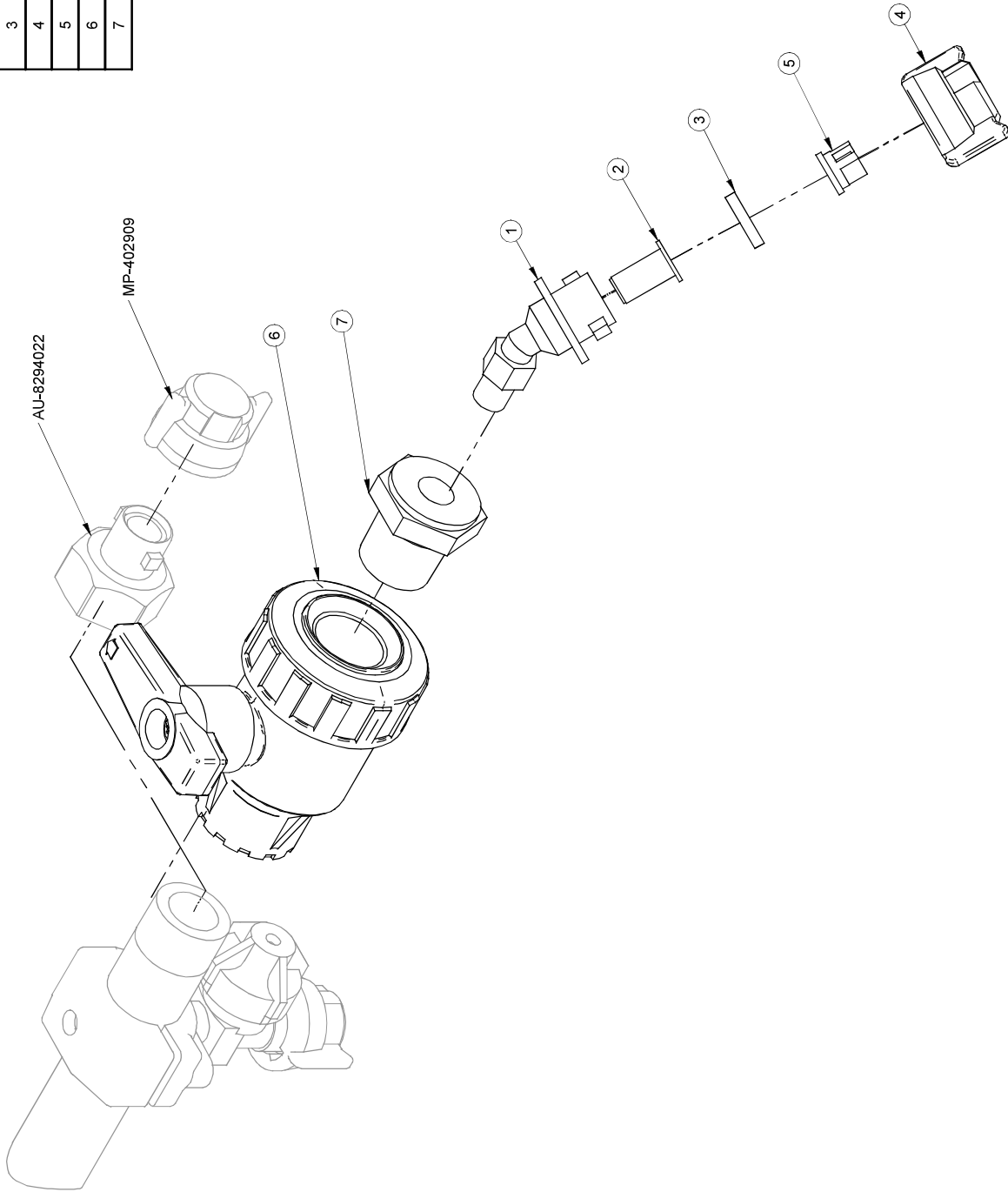

2008/12/10	AR800-0004.asm	Rev. 0	Pg:1-1
	AR800-0004.dft		AR800-0004

#	REF.	Q.	L"
8	AU-1271	1	40"

#	REF.	Q.
1	GF-RS02Z39	2
2	AU-UB14112214	4
3	BT-FW14SS	16
4	BT-LN14SS	12
5	BT-14114	4
6	AU-54003040	1
7	A800-0019	2

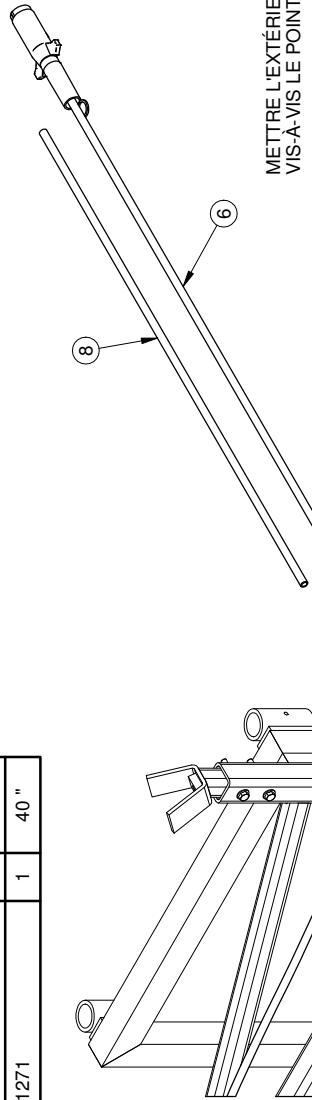

METTRE L'EXTÉRIEUR DE LA LUMIÈRE.
VIS-À-VIS LE POINT LE PLUS LARGE DE LA RAMPE

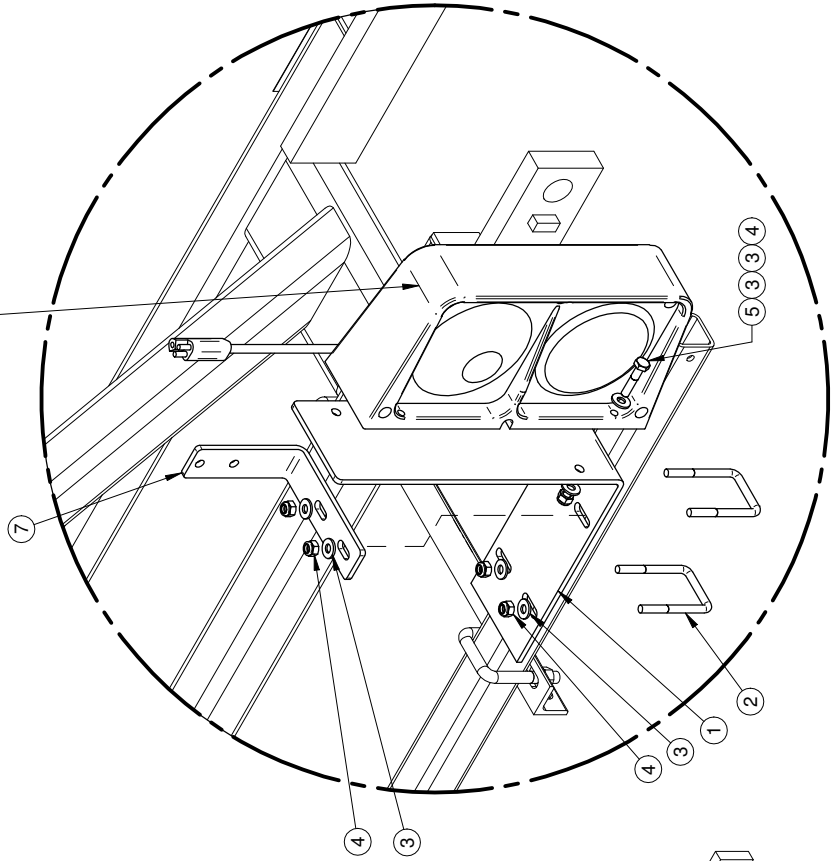

DETAIL A
1:6

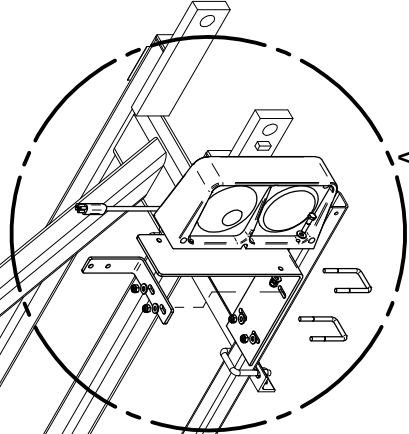

1- LES VALEURS SONT EN POUCES SAUF SI SPECIFIÉ UNITS ARE IN INCHES UNLESS OTHERWISE SPECIFIED 2- TOLERANCES GÉNÉRALES GENERAL TOLERANCES Frac.: ± 1/16" X.X: ± 0.01" X.XX: ± 0.1" X.XXX: ± 0.005"		# FEUILLE / SHEET # AR830-0013	DATE CREATION 2014-08-26	CRÉATEUR / CREATOR cyrennep	REVISION PAR / BY allardrp	PAGE 1 of 1
		DESCRIPTION ENSEMBLE DE LUMIÈRES POUR RAMPES HV #DESSIN / DRAWING # AR830-0013	REVISION	ECHELLE / SCALE 1:12	REVISION	3
AVIS: l'information ci-incluse a été fournie par MSG GREGGSON en vertu des droits de propriété, licence, commercialisation, fabrication et/ou droits de reproduction. Toute réimpression sans autorisation écrite de MSG GREGGSON, qui conserve all patent rights thereon, est interdite.						
Rev	Description	Date	Approbation			

#	REF.	Q.	L"
1	A830-0014	2	
2	AU-UB14112214	4	
3	BT-FW14	16	
4	BT-LN14	12	
5	BT-14114	4	
6	AU-54003040	1	
7	AU-1271	1	40"

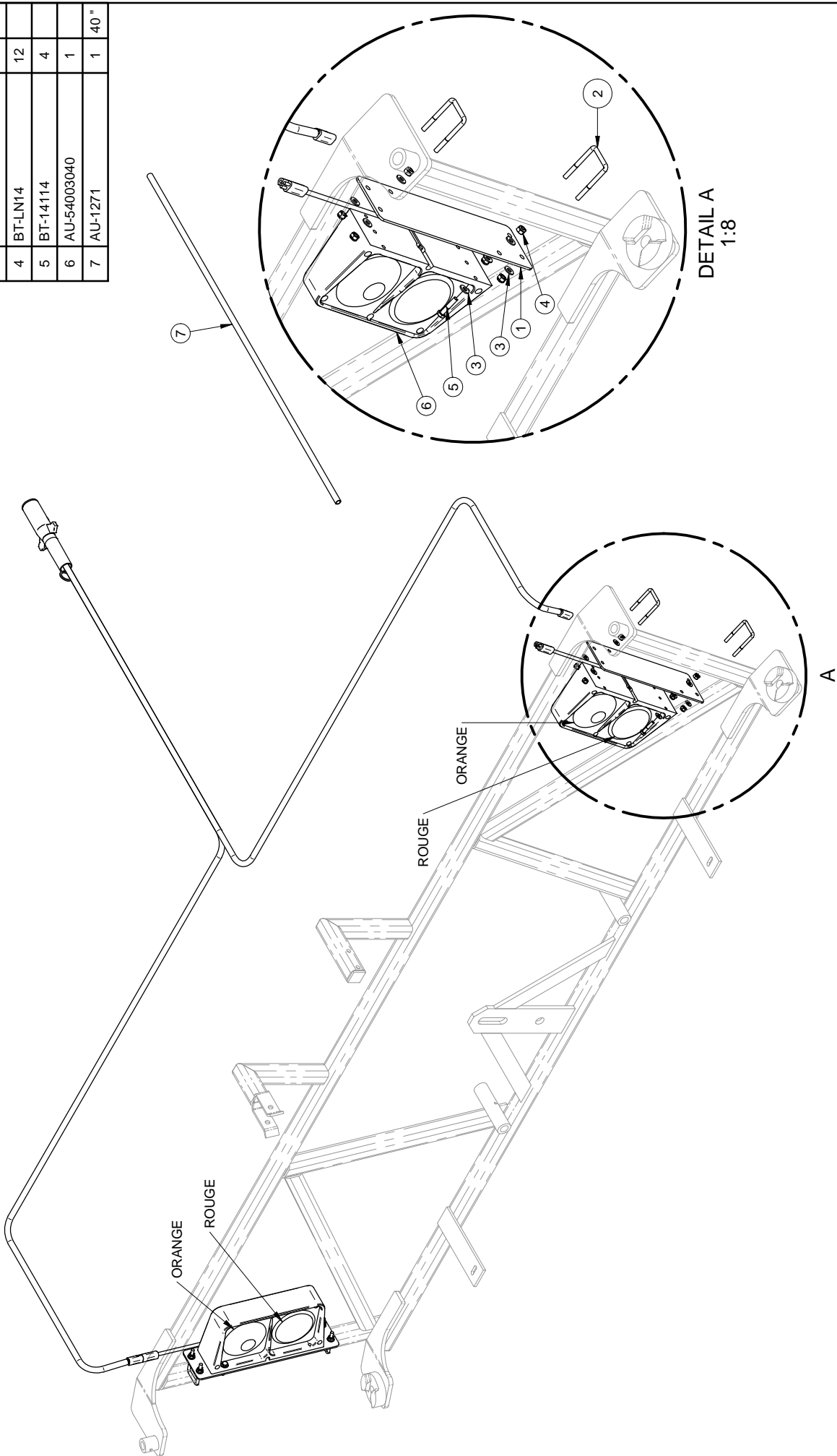

Rev	Description	Date	Approbation

AVIS / Information c-incluse à 46	# FEUILLE / SHEET #	DATE CREATION	CREATEUR / CREATOR	REVISION DATE	PAGE
de M S G R E S S O N et qui ne peuvent être	AR830-0014	2014/08/26	roya	2017/01/11	1 of 1
utilisés sans autorisation écrite de M S G R E S S O N	DESCRIPTION			REVISION PAR / BY	
pour les droits de propriété, licence,	ENSEMBLE DE LUMIERES POUR RAMPES MANUEL			allardp	
commercialisation, fabrication et/ou tout	#DESSIN / DRAWING #			ECHELLE / SCALE	
droit de reproduction. Toute réimpression	AR830-0014			1:12	
ou utilisation non autorisée sans la permission				REVISION	1
écrite de M S G R E S S O N, qui réserve all patent					
rights thereof.					

#	Ref.	Q.
1	4200029	1
2	MS-BRHV50FJ	1
3	AU-UB3823	1
4	BT-14114	2
5	BT-FW14	4
6	BT-FW38	2
7	BT-LN38	2
8	BT-N14	2
9	BT-AP1234	2

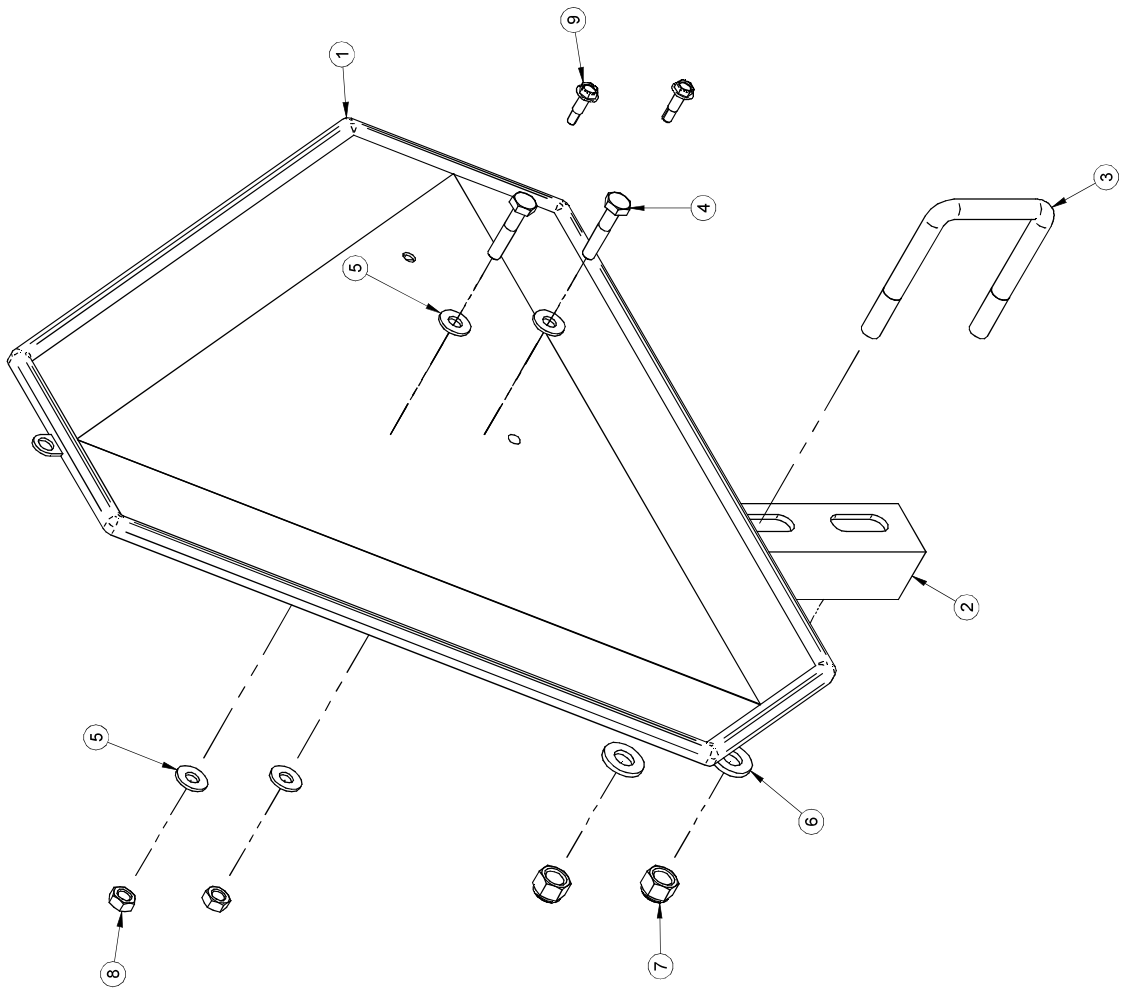

2011/11/24	RE-ENSSMV.asm	Pg:1-1
	Rev. 2	
	RE-ENSSMV.dft	sheet

#	REF.	Q.	L"
1	A840-0001	1	
2	4200029	1	
3	BT-FW14	4	
4	BT-141	2	
5	BT-LN14	2	
6	BT-FW516	2	
7	BT-5161	1	
8	BT-LN516	1	

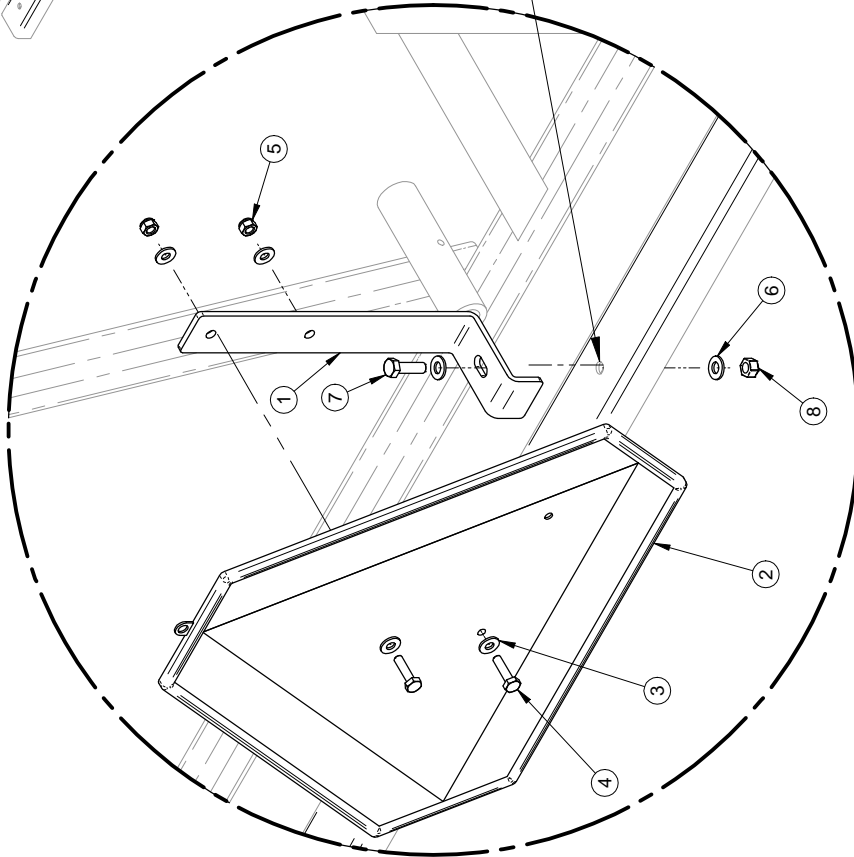
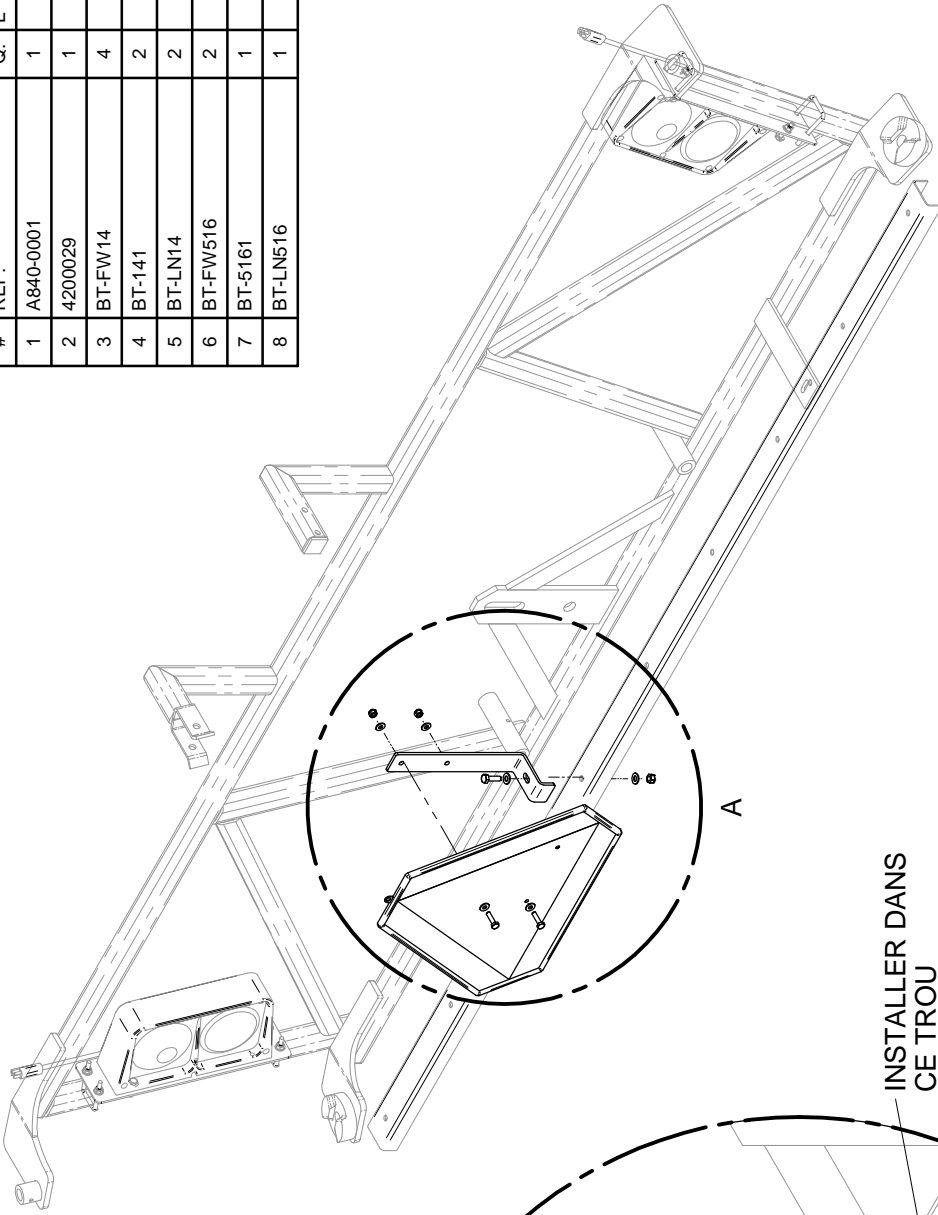

INSTALLER DANS
CE TROU

DETAIL A
1:5.56

1- LES VALEURS SONT EN
POUCE SAUF SI SPECIFIE
UNITS ARE IN INCHES
UNLESS OTHERWISE NOTED
2- TOLERANCES GENERALES
Frac.: ± 1/16"
Dec.: ± 0.01"
X.X: ± 0.1"
X.XX: ± 0.005"
X.XXX: ± 0.0005"



AVIS: L'information contenue a été
fournie par RAD TECHNOLOGIES INC. qui se
réserve tous les droits de propriété,
intellectuelle, commerciale, industrielle et
droits de reproduction. Toute réimpression
sans autorisation écrite de RAD
TECHNOLOGIES INC. est interdite.
#Dessin / Drawing #
AR840-0001

# FEUILLE / SHEET #	DATE CREATION	CREATEUR / CREATOR	REVISION DATE	PAGE
AR840-0001	2015/03/31	roya	2015/04/01	1 of 1
DESCRIPTION		REVISION PAR / BY	REVISION DATE	REVISION
Ensemble d'identification « véhicule lent »		roya		0
			ECHELLE / SCALE	1:12

Rev	Description	Date	Approbation

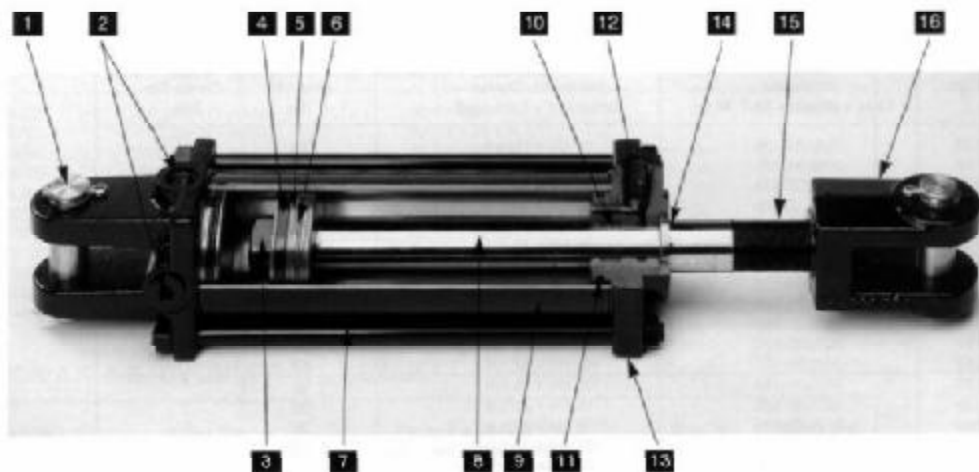

REF	DESCRIPTION
1	Pins and retainers
2	Ports
3	Piston nut
4	Piston wear ring
5	Piston
6	Piston seal
7	Tie-rods
8	Cylinder shaft
9	Tube
10	Rod wear ring
11	Tube seal
12	Rod seal
13	Rod cap & clevis cap
14	Rod wiper
15	Threaded shaft (on ASAE cylinders)
16	Rod clevis

No	DESCRIPTION	SÉRIE	PRESSION MAX. (LB/PO ²)	BORE (PO)	LONGUEUR (PO) RÉTRACTÉ x ÉTENDU	PORT	REPAIR KIT
MI-639704	Cylindre 2 3/4" x 8" double action	TP	3000	2.75	20.25 x 28.25	3/4-16 FORB	MI-639557
MI-639703	Cylindre 2 1/2" x 8" double action	TP	3000	2.5	20.25 x 28.25	3/4-16 FORB	MI-639555
MI-639280	Voir MI-643449	TD	3000	2	20.25 x 28.25	3/4-16 FORB	MI-639542
MI-643276	Cylindre 2" dia. x 3" (gauche)	TH	3000	2.0 x 3.0	11.75 x 14.75	3/4-16 FORB	MI-639542
MI-643433	Cylindre TL 2" x 20" x 1 1/8" tige tige NT, 3/8 FNPT	TL	2500	2.0 x 20	30.25 x 50.25	3/8" FNPT	MI-637529
MI-643434	Cylindre TH 2 1/2" x 8" x 1 1/8" tige tige NT, 3/4-16 FORB	TH	3000	2.5 x 8	20.25 x 28.25	3/4-16 FORB	MI-639555
MI-643444	Cylindre TL 2 1/2" x 16" x 1 1/8" tige tige NT, 3/8" FNPT	TL	2500	2.5 x 16	26.50 x 42.50	3/8" FNPT	MI-643658
MI-643445	Cylindre TH 2 1/2" x 20" x 1 1/8" tige tige NT, 3/4-16 FORB	TH	3000	2.5 x 20	30.50 x 50.50	3/4-16 FORB	MI-643658
MI-643449	Cylindre TH 2" x 8" x 1 1/8" tige tige NT, 3/4-16 FORB	TH	3000	2.0 x 8	20.25 x 28.25	3/4-16 FORB	MI-639555
MI-643645	Cylindre TH 2 1/2" x 10" x 1 1/8" tige tige NT, 3/4-16 FORB	TH	3000	2.5 x 10	20.50 x 30.50	3/4-16 FORB	MI-639555
MI-643658	Voir 639573						
MI-643661	Cylindre 2 1/2" x 12", 3/4 - 16 forb PULL	TD	3000	2.5 x 12	22.25 x 34.25	3/4-16 FORB	MI-637696
MI-643662	Cylindre 2 1/2" x 20" PULL	TD	3000	2.5 x 20	30.25 x 50.25	3/4-16 FORB	MI-637697
MI-643666	Cylindre 2 1/2" x 18" PULL	TD	3000	2.5 x 18	28.25 x 46.25	3/4-16 FORB	MI-637697
MI-643668	Cylindre 2" x 10" double action			2.0 x 10			MI-639572
MI-643741	Cylindre TH 3 1/2" x 8" x 1 1/4" tige tige NT, 3/4-16 FORB	TH	3000	3.5 x 8	20.25 x 28.25	3/4-16 FORB	MI-639561
MI-643831	Cylindre 2 1/2" x 14" Push nitrosteel	TD	3000	2.5 x 14	24.25 x 38.25	3/4-16 FORB	MI-637696
MI-643910	Cylindre 2 1/2" x 8" double action			2.5 x 8			MI-639555
MI-643911	Cylindre 2 3/4" x 8" double action			2.75 x 8			MI-639557
MI-644358	Cylindre 2" x 8" x 1 1/8" tige tige NT, soudé 7/8-14 FORB	TH	3000	2.0 x 8	22.25 x 30.25	7/8-14 FORB	MI-644373
MI-644359	Cylindre 2 1/2" x 8" x 1 1/8" tige tige NT, soudé 7/8-14 FORB Voir MI-644500	TH	3000	2.5 x 8	22.25 x 30.25	7/8-14 FORB	MI-644373
MI-644499	Cylindre 2" x 8" x 1 1/8" tige tige NT, soudé 1 1/16 FORB	TH	3000	2.0 x 8	22.25 x 30.25	1 1/16-12 FORB	MI-644373
MI-644500	Cylindre 2 1/2" x 8" x 1 1/8" tige tige NT, soudé 1 1/16 FORB Voir MI-644500R1	TH	3000	2.5 x 8	22.25 x 30.25	1 1/16-12 FORB	MI-644373
MI-644500R1	Cylindre 2 1/2" x 8" x 1 1/8" nt, soudé 1 1/16 forb.			2.5 x 8		1 1/16 FORB	
MI-645162	Cylindre TH 2 1/2" x 16" x 1 1/8" tige tige NT, 3/4-16 FORB	TH	3000	2.5 x 16	27.15 x 43.15	3/4-16 FORB	MI-649573
MI-645296	Cylindre TH 2" x 20" x 1 1/8" tige tige NT, 3/4-16 FORB	TH	3000	2.0 x 20	30.25 x 50.25	3/4-16 FORB	MI-639542
MI-645297	Cylindre TH 2 1/2" x 16" x 1 1/8" tige tige NT, 3/4-16 FORB Voir MI-645760	TH	3000	2.5 x 16	26.50 x 42.50	3/4-16 FORB	MI-639555
MI-645298	Cylindre TH 2 1/2" x 20" x 1 1/8" tige tige NT, 3/4-16 FORB	TH	3000	2.5 x 20	30.50 x 50.50	3/4-16 FORB	MI-639555
MI-645298R1	Cylindre TH 2 1/2" x 20" x 1 1/8" tige tige NT, 3/4-16 FORB	TH	3000	2.5 x 20	30.50 x 50.50	3/4-16 FORB	MI-SKTR325001125
MI-645346	Cylindre TH 2 1/2" x 10" x 1 1/8" tige tige NT, 3/4-16 FORB	TH	3000	2.5 x 10	18.15 x 28.15	3/4-16 FORB	MI-645004
MI-645347	Cylindre TH 3" x 20" x 1 1/2" tige tige NT, 3/4-16 FORB	TH	3000	3.0 x 20	30.25 x 50.25	3/4-16 FORB	MI-645599
MI-645374	Cylindre 2" dia. x 24" double action	TD	3000	2.0 x 24	34.25 x 58.25	3/4-16 FORB	MI-639542
MI-645375	Cylindre 2 1/2" x 8" tige nitro-steel, seal PTFE	TD	3000	2.5 x 8	18.25 x 26.25	3/4-16 FORB	MI-639555
MI-645376	Cylindre 2 1/2" dia. x 10" double action	TD	3000	2.5 x 10	20.25 x 30.25	3/4-16 FORB	MI-639555
MI-645377	Cylindre 2 1/2" dia. x 30" double action	TD	3000	2.5 x 30	40.25 x 70.25	3/4-16 FORB	MI-639556
MI-645488	Cylindre 2" dia. x 12" double action	TD	3000	2.0 x 12	22.25 x 34.25	3/4-16 FORB	MI-639542
MI-645489	Cylindre 2 1/2" dia. x 12" double action	TD	3000	2.5 x 12	22.25 x 34.25	3/4-16 FORB	MI-639555

No	DESCRIPTION	SÉRIE	PRESSION MAX. (LB/PO ²)	BORE (PO)	LONGUEUR (PO) RÉTRACTÉ x ÉTENDU	PORT	REPAIR KIT
MI-645505	Cylindre TH 2 1/2" x 14" x 1 1/8" tige tige NT, 3/4-16 FORB	TH	3000	2.5 x 14	24.25 x 38.25	3/4-16 FORB	MI-645004
MI-645625	Cylindre 2" x 20" Push	TD	3000	2.0 x 20	20.25 x 50.25	3/4-16 FORB	MI-645724
MI-645626	Cylindre 2 1/2" x 12" double action	TD	3000	2.5x 12	22.25 x 34.25	3/4-16 FORB	MI-639555
MI-646027	Cylindre 3" x 12" double action	TD	3000	3.0 x 12	22.25 x 34.25	3/4-16 FORB	MI-639558
MI-645628	Cylindre 3" x 14" simple double action pull	TD	3000	3.0 x 14	24.25 x 38.25	3/4-16 FORB	MI-645765
MI-645760	Cylindre TH 2 1/2" x 16" x 1 1/8" tige tige NT, 3/4-16 FORB	TH	3000	2.5 x 16	26.50 x 42.50	3/4-16 FORB	MI-645004
MI-645761	Cylindre TH 3" x 14" x 1 1/4" tige tige NT, 3/4-16 FORB	TH	3000	3.0 x 14	24.25 x 38.25	3/4-16 FORB	MI-645599
MI-645762	Cylindre TH 2 1/2" x 30" x 1 1/4" tige tige NT, 3/4-16 FORB	TH	3000	2.5 x 30	26.50 x 56.50	3/4-16 FORB	MI-639556
MI-645782	Cylindre 3" x 14" simple action push	TD	3000	3 X 14	24.25 x 38.25	3/4-16 FORB	MI-645765
MI-645861	Cylindre TH 3" x 18" x 1 1/2" tige tige NT, 3/4-16 FORB	TH	3000	3.0 x 18	26.50 x 44.50	3/4-16 FORB	MI-645589
MI-646400	Cylindre ASAE 2 1/2" x 8" x 1 1/8"nt, 3/4 - 16 forb, PSP seal	TD	3000	2.5 x 8	20.25 x 28.25	3/4-16 FORB	MI-639555
MI-646475	Cylindre 2" x 20" x 1 1/8"nt, seal PSP	TD	3000	2.0 x 20	30.25 x 50.25	3/4-16 FORB	MI-639542
MI-646475R1	Cylindre 2" x 20" x 1 1/8"nt, seal PSP	TD	3000	2.0 x 20	30.25 x 50.25	3/4-16 FORB	MI-SKTCL2020N0176
MI-646476	Cylindre ASAE 2 1/2" x 10" c 1 1/8"nt, 3/4 - 16 forb, PSP seal	TD	3000	2.5 x 10	22.25 x 32.25	3/4-16 FORB	MI-639555
MI-646476R1	Cylindre ASAE 2 1/2" x 10" c 1 1/8"nt, 3/4 - 16 forb, PSP seal	TD	3000	2.5 x 10	22.25 x 32.25	3/4-16 FORB	MI-SKTCL2510N0177
MI-646477	Cylindre ASAE 2 1/2" x 12" c 1 1/8"nt, 3/4 - 16 forb, PSP seal	TD	3000	2.5 x 12	24.25 x 36.25	3/4-16 FORB	MI-637696
MI-646477R1	Cylindre ASAE 2 1/2" x 12" c 1 1/8"nt, 3/4 - 16 forb, PSP seal	TD	3000	2.5 x 12	24.25 x 36.25	3/4-16 FORB	MI-SKTR325001125

No	DESCRIPTION	SÉRIE	PRESSION MAX. (LB/PO ²)	BORE (PO)	LONGUEUR (PO) RÉTRACTÉ x ÉTENDU	PORT
AU-CYL2530	Cylindre 2 1/2" x 30" x 1 1/4" tige niturer, 3/8" FNPT	-	3000	2.5 x 30	-	3/8" FNPT
AU-CYL2048	Cylindre 2" x 40" x 1 1/2" tige chromé, 3/8" FNPT	-	3000	2.0 x 40	-	3/8" FNPT
AU-CYL2080	Cylindre 2" x 80" x 1 1/4" tige chromé, 3/8" FNPT	-	3000	2.0 x 80	-	3/8" FNPT
AU-CYL2505	Cylindre 2 1/2" x 4" x 1 1/2" tige chromé, 3/8 FNPT	-	3000	2.5 x 4	-	3/8" FNPT
ENSEMBLE DE RÉPARATION						
AU-CYL2048KC	Ensemble réparation pour AU-CYL2048 2000 et plus					
AU-CYL2048K	Ensemble réparation pour AU-CYL2048 2000 et moins					
AU-CYL2505K	Ensemble réparation pour cylindre AU-CYL2505					

ACCESSOIRES

NO	DESCRIPTION
MS-BRH18P	Limiteur de course vissé, 1-1/8"
MS-BRH18P2	Limiteur de course vissé, 1-1/4"
MS-BRH180	Man avec attache pour écrou
MO-437393	Man de cylindre, tige 1-1/8"
MO-419396	Pin 1"
AU-91105	Stoppeur de course 2-1/2" avec clip plaqué

JET AGITATOR and VOLUME BOOSTER MODEL 3371-0019

The versatile Hypro, venturi type, 3371-0019 Jet Agitator adapts to your installation, fits directly into 3/4" NPT tank opening. Mounts vertically or horizontally. (For horizontal mounting, just remove end cap from agitator. The full flow is then directed across the tank.) The overlapping 4-port side outlet provides full 360° agitation for thorough mixing in the vertical position. Molded polypropylene construction provides rigidity and strength. Choice of four nozzles assures proper agitation for your spraying.



ASSEMBLY INSTRUCTIONS

1. Agitator is packaged for shipment disassembled in a see-through plastic envelope. Select your nozzle size and assemble as shown on the sectional drawing. Insert small diameter of nozzle into tank adapter. Thread parts together in order shown. Note that body section end with vertical slots screws into tank adapter (other end is for cap).
2. Wrap teflon tape on the inside 3/4" NPT thread on agitator before installing to tank. This assures a tight seal and will prevent agitator from loosening because of vibration.
3. Apply teflon tape on the outside 3/4" NPT thread for agitator line and install a metal coupling. This will assure a tight seal and prevent breakage of agitator.

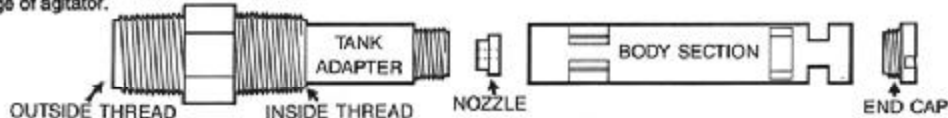

SELECTING THE PROPER NOZZLE FOR SPRAY TANK AGITATION

The right nozzle is the one which provides ample agitation to keep the wettable powders in suspension, but not too much as to cause foaming of spray material.

PERFORMANCE TABLE MODEL 3371-0019

Nozzle Diameter	Input to Agitator in GPM	Input to Agitator in L/min.	Agitator Pressure in PSI	Agitator Pressure in KPa	Agitator Output in GPM	Agitator Output in L/min.
1/8"	2.1	7.9	25	172.4	6	22.7
1/8"	2.9	11	50	344.7	8.8	33.3
1/8"	4.1	15.5	100	689.4	13.9	52.6
5/32"	3.1	11.7	25	172.4	7	26.5
5/32"	4.5	17	50	344.7	11.5	43.5
5/32"	5.8	22	100	689.4	16.2	61.3
3/16"	3.8	14.4	25	172.4	8.5	32.2
3/16"	5.9	22.3	50	344.7	12.8	48.4
3/16"	8.2	31	100	689.4	17.2	65.1
1/4"	5.9	22.3	25	172.4	11.9	45
1/4"	9.8	37.1	50	344.7	17.1	64.7
1/4"	13.5	51.1	100	689.4	20	75.7

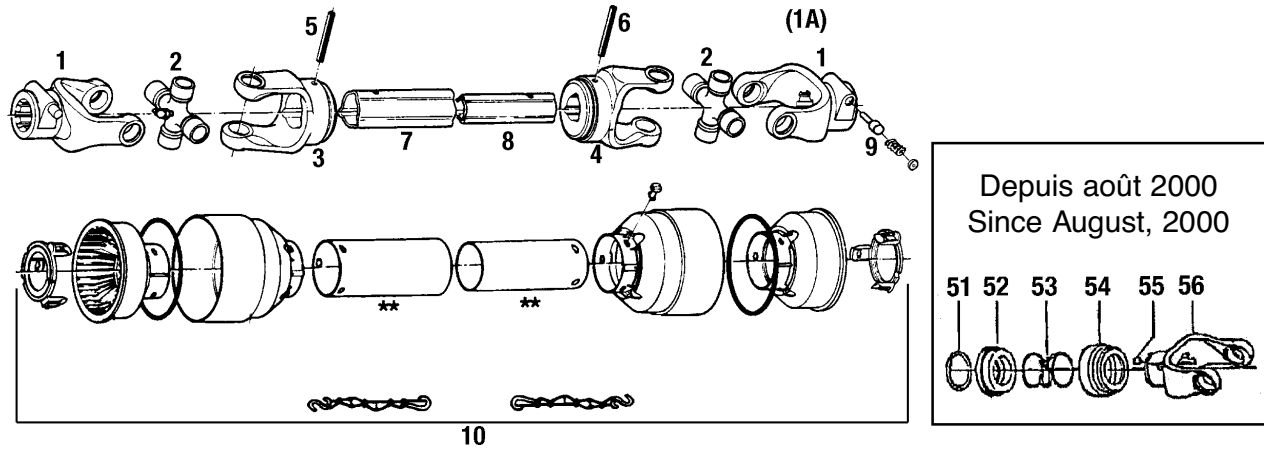

Series	T20	T20	T20	T50	T60		
**	26-1/2"	47-1/2"	26-1/2"	26-1/2"	26-1/2"		
REF	CA-PT001	CA-PT002	CA-PT003	CA-PT005	CA-PT006	DESCRIPTION	Q
1	CA-022001	CA-022001				Yoke, 1-3/8" x 6 splines	1
			CA-022001	CA-141025001	CA-141026544	Yoke, 1-3/8 x 6 splines	2
1A	CA-012304					Yoke, 1"	1
		CA-022108				Yoke, 1-1/4"	1
2	CA-41202	CA-41202	CA-41202	CA-180015130	CA-180016130	Cross	2
3	CA-012003	CA-012003	CA-012003	CA-151015011	CA-151016028	Outer yoke	1
4	CA-012002	CA-012002	CA-012002	CA-151015012	CA-151016029	Inner yoke	1
5	CA-190000014	CA-190000014	CA-190000014	CA-190000016	CA-190000018	Pin	1
6	CA-190000012	CA-190000012	CA-190000012	CA-190000394	CA-190000016	Pin	1
7	CA-191120200300	CA-191120200300	CA-191120200300	CA-191150200	CA-191160200	Outer tube	1
8	CA-191120100300	CA-191120100300	CA-191120100300	CA-191150100	CA-191150100	Inner tube	1
9	CA-166026004	CA-166026004	CA-166026004	CA-166026004	CA-166026004	Spring and pin	1
10	CA-220209	CA-220214	CA-220209	CA-142250209	CA-142260030	Guard assy	1
51	CA-190000451	CA-190000451	CA-190000451		CA-190000451	Outer clip	1
52	CA-151016486	CA-151016486	CA-151016486		CA-151016486	Sliding sleeve collar	1
53	CA-180016487	CA-180016487	CA-180016487		CA-180016487	Spring	1
54	CA-180016483	CA-180016483	CA-180016483		CA-180016483	Fixed sleeve	1
55	CA-190000078	CA-190000078	CA-190000078		CA-190000078	Ball ø 1/2"	1
56	CA-151012324	CA-151012324	CA-151012324			Yoke C12	1

** Cross CC length

Series	T20	T40	T40	T40	T20		
**	36"	19"	48"	SIMPLE	SIMPLE		
REF	CA-PT007	CA-PT008	CA-PT00448	CA-PT009	CA-PT010	DESCRIPTION	Q
1	CA-022001	CA-141024430		CA-141024430	CA-022001	Yoke, 1-3/8" x 6 splines	1
			CA-141024430			Yoke, 1-3/8 x 6 splines	2
1A					CA-151014303	Yoke, 1"	1
	CA-022108	CA-151014302		CA-151014302		Yoke, 1-1/4"	1
2	CA-41202	CA-180014130	CA-180014130	—	CA-41202	Cross	2
3	CA-012003	CA-151014006	CA-151014006	—	—	Outer yoke	1
4	CA-012002	CA-151014007	CA-151014007	—	—	Inner yoke	1
5	CA-190000014	CA-190000014	CA-190000014	—	—	Pin	1
6	CA-190000012	CA-190000012	CA-190000012	—	—	Pin	1
7	CA-191120200300	CA-191130200	CA-191130200	—	—	Outer tube	1
8	CA-191120100300	CA-191140100	CA-191140100	—	—	Inner tube	1
9	CA-166026004	CA-166026004	CA-166026004	—	—	Spring and pin	1
10	CA-220214	CA-142240209	CA-142240209	—	—	Guard assy	1
51	CA-190000451	CA-190000451	CA-190000451	—	—	Outer clip	1
52	CA-151016486	CA-151016486	CA-151016486	—	—	Sliding sleeve collar	1
53	CA-180016487	CA-180016487	CA-180016487	—	—	Spring	1
54	CA-180016483	CA-180016483	CA-180016483	—	—	Fixed sleeve	1
55	CA-190000078	CA-190000078	CA-190000078	—	—	Ball ø 1/2"	1
56	CA-151012324			—	—	Yoke C12	1

** Cross CC length

Series	T20	T20	T40	T40	T20		
**	19"	19"	19"	26-1/2"	36"		
REF	CA-PT00119	CA-PT00319	CA-PT00419	CA-PT00426	CA-PT00758	DESCRIPTION	Q
1	CA-022001					Yoke, 1-3/8" x 6 splines	1
		CA-022001	CA-141024430	CA-141024430	CA-022001	Yoke, 1-3/8 x 6 splines	2
1A	CA-012304					Yoke, 1"	1
					CA-01230458	Yoke, 5/8"	1
2	CA-41202	CA-41202	CA-180014130	CA-180014130	CA-41202	Cross	2
3	CA-012003	CA-012003	CA-151014006	CA-151014006	CA-151015011	Outer yoke	1
4	CA-012002	CA-012002	CA-151014007	CA-151014007	CA-151015012	Inner yoke	1
5	CA-190000014	CA-190000014	CA-190000014	CA-190000014	CA-190000016	Pin	1
6	CA-190000012	CA-190000012	CA-190000012	CA-190000012	CA-190000394	Pin	1
7	CA-191120200300	CA-191120200300	CA-191130200	CA-191130200	CA-191150200	Outer tube	1
8	CA-191120100300	CA-191120100300	CA-191140100	CA-191140100	CA-191150100	Inner tube	1
9	CA-166026004	CA-166026004	CA-166026004	CA-166026004	CA-166026004	Spring and pin	1
10	CA-220209	CA-220209	CA-142240209	CA-142240209	CA-142220211	Guard assy	1
51	CA-190000451	CA-190000451	CA-190000451	CA-190000451	CA-190000451	Outer clip	1
52	CA-151016486	CA-151016486	CA-151016486	CA-151016486	CA-151016486	Sliding sleeve collar	1
53	CA-180016487	CA-180016487	CA-180016487	CA-180016487	CA-180016487	Spring	1
54	CA-180016483	CA-180016483	CA-180016483	CA-180016483	CA-180016483	Fixed sleeve	1
55	CA-190000078	CA-190000078	CA-190000078	CA-190000078	CA-190000078	Ball ø 1/2"	1
56	CA-151012324	CA-151012324			CA-151012324	Yoke C12	1

** Cross CC lenght

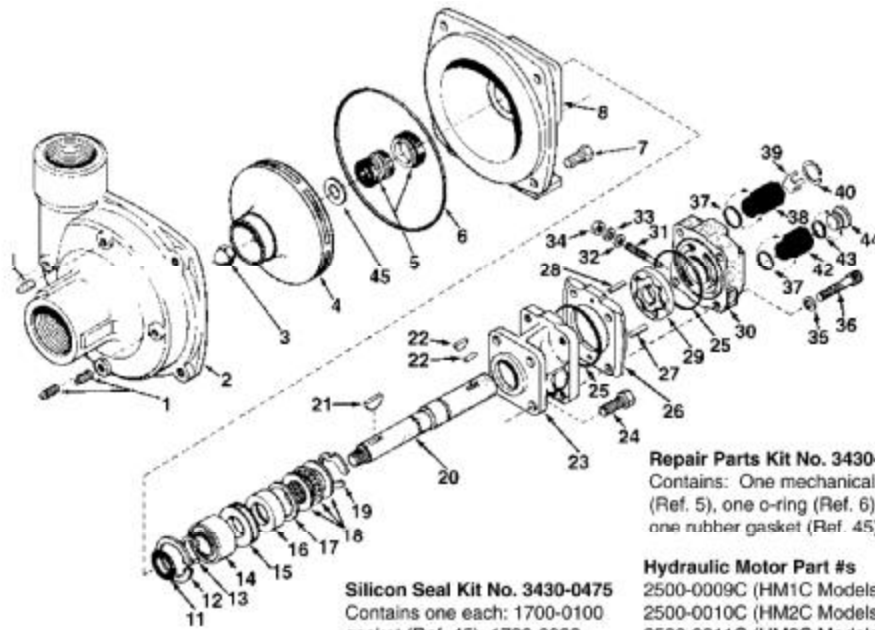

NOTE: When ordering parts, give QUANTITY, PART NUMBER, DESCRIPTION, and COMPLETE MODEL NUMBER. Reference numbers are used ONLY to identify parts in the drawing and are NOT to be used as order numbers.

Parts Kit No. 3430-0178
 Contains: One each ball bearing (Ref. 14), motor shaft seal (Ref. 16), thread seal gasket (Ref. 32), and washer (Ref. 33), two each motor housing o-rings (Ref. 25), and port adapter o-rings (Ref. 37).

Repair Parts Kit No. 3430-0332
 Contains: One mechanical seal (Ref. 5), one o-ring (Ref. 6) and one rubber gasket (Ref. 45).

Silicon Seal Kit No. 3430-0475
 Contains one each: 1700-0100 gasket (Ref. 45), 1720-0083 o-ring (Ref. 6) and 2120-0032 seal (silicon carbide) (Ref. 5).

Hydraulic Motor Part #s
 2500-0009C (HM1C Models)
 2500-0010C (HM2C Models)
 2500-0011C (HM3C Models)
 2500-0012C (HM4C Models)
 2500-0018C (HM5C Models)
 2500-0033 (CTGM1 Models)

Adapter Kit No. 3430-0187 (HM4 Models Only):
 Includes one each Ref. 37, Ref. 42, and Ref. 44, three Ref. 43, three metering orifices one No. 3373-0020 (Size #1), one No. 3373-0021 (Size #2) and one No. 3373-0022 (Size #3).

REF N°	DESCRIPTION	Q	REF N°	DESCRIPTION	Q
1	JB-24060007 Drain/Vent Plug	4	24	JB-22100005 Hex Head Cap Screw	4
2	JB-01509000C Pump Casing (Volute) (Includes a stainless steel wear ring) (Model 9303C)	1	25	JB-17200110 O-ring	2
2	JB-01509000S Pump Casing (Model 9303S)	1	26	JB-07012500C Gerotor Housing (HM2C Models) 1/4" Wide	1
2	JB-01509200C Pump Casing (Model 9302C)	1	26	JB-07002500C Gerotor Housing (HM1C Models) 1/2" Wide	1
2	JB-01509200S Pump Casing (Model 9302S)	1	26	JB-07032500C Gerotor Housing (HM4C Models) 5/16" Wide	1
3	JB-22530002 Impeller Nut	1	26	JB-07022500C Gerotor Housing (HM3C Models) 1" Wide	1
3	JB-22530002 Impeller Nut (Model 9302S & 9303S)	1	26	JB-07042500C Gerotor Housing (HM5C Models) 5/8" Wide	1
4	JB-04019100P Impeller (Nyglass, std.)	1	27	JB-16000045 Dowel Pin (HM2C & HM4C Models)	1
4	JB-04029100P Impeller (Optional Polypropylene) (Std 9302S & 9303S)	1	27	JB-16000044 Dowel Pin (HM1C & HM5C Models)	1
5	JB-21200008 Mechanical Seal (Buna-N) (9301C & 9302S)	1	27	JB-16000052 Dowel Pin (HM3C Models)	1
5	JB-21200009 Mechanical Seal (Viton) (9302C & 9303C)	1	28	JB-16000042 Dowel Pin (HM2C & HM4C Models)	1
5	JB-21200032 Mechanical Seal (Silicon Carbide) (9302S & 9303S)	1	28	JB-16000037 Dowel Pin (HM1C & HM5C Models)	1
6	JB-17200083 O-ring	1	28	JB-16000068 Dowel Pin (HM3C Models)	1
7	JB-22100020 Hex Head Cap Screw	7	29	JB-39000022 Gerotor (HM1C Models)	1
7	JB-22100125 Hex Head Cap Screw (Model 9302S & 9303S)	7	29	JB-39000023 Gerotor (HM2C Models)	1
8	JB-07509300C Mounting Flange	1	29	JB-39000024 Gerotor (HM3C Models)	1
8	JB-07509300S Mounting Flange (Model 9302S & 9303S)	1	29	JB-39000025 Gerotor (HM4C Models)	1
11	JB-14100056 Slinger Ring	1	29	JB-39000048 Gerotor (HM5C Models)	1
12	JB-18200013 Retaining Ring	1	30	JB-02512500C Motor End Plate (Includes Main Bearing)	1
13	JB-18100014 Snap Ring	1	31	JB-32200029 Bypass Adjusting Screw	1
14	JB-20000010 Ball Bearing	1	32	JB-17000047 Gasket	1
15	JB-14100073 Spacer	1	33	JB-22700027 Washer	1
16	JB-21040005 Shaft Seal	1	34	JB-22500038 Lock Nut	1
17	JB-14100074 Seal Spacer	1	35	JB-22700039 Washer	4
18	JB-20290014 Thrust Bearing Assembly—Consists of: (1) Thrust Bearing & (2) Thrust Brg. Races	1	36	JB-22200045 Cap Screw (HM2C & HM4C Models)	4
19	JB-18100026 Snap Ring	1	36	JB-22200021 Cap Screw (HM1C & HM5C Models)	4
20	JB-05092500 Shaft (HM2C & HM4C Models) 6 3/4" Long	1	36	JB-22200044 Cap Screw (HM3C Models)	4
20	JB-05112501 Shaft (HM1C & HM5C Models) 7" Long	1	37	JB-17200108 O-ring	2
20	JB-05102500 Shaft (HM3C Models) 7 1/2" Long	1	38	JB-33200016 Tank Port Adapter	1
21	JB-16100012 Woodruff Key	1	39	JB-32600039 Poppet	1
21	JB-04432 S.S. Woodruff Key (Model 9302S & 9303S)	1	40	JB-18200023 Retaining Ring	1
22	JB-16100032 Roll Pin (HM2C & HM4C Models)	1	42	JB-33600021 Pressure Port Adapter	1
22	JB-16100031 Roll Pin (HM1C & HM5C Models)	1	43	JB-17200105 Orifice O-ring (HM2C & HM4C Models Only)	1
22	JB-16100030 Woodruff Key (HM3C Models)	1	44	JB-33730020 Metering Orifice (HM2C & HM4C Models Only)	1
23	JB-01512500C Motor Body (Includes Main Bearing)	1	45	JB-17000100 Rubber Gasket	1

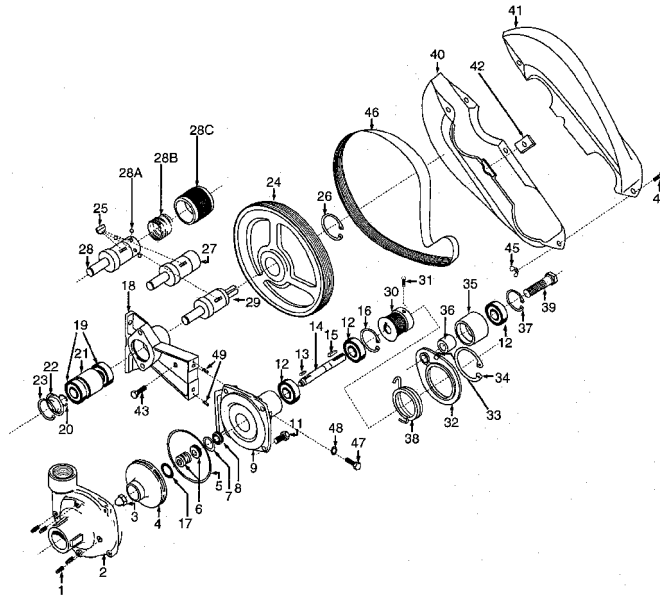

REF NO	DESCRIPTION	Q	REF NO	DESCRIPTION	Q
1	JB-24060007 Drain plug	4	27	JB-05559400F Shaft (540 rpm) (JB-34300207 kit used on JB-5559400F and JB-5569400F shafts)	1
2	JB-01509000C Pump casing (Models 9403C)	1		JB-05569400F Shaft (1000 rpm) (JB-34300207 kit used on JB-5559400F and JB-5569400F shafts)	1
3	JB-22530002 Impeller nut	1	27	JB-05579400F Shaft (1 3/4", 1000 rpm) (JB-34300207 kit used on JB-5559400F and JB-5569400F shafts)	1
4	JB-04019100P Impeller, nylon	1	28	JB-05559400F1 Shaft (540 quick coupler)	1
	JB-04029100P Impeller, nylon	1	28A	JB-32500004 Locking ball	3
5	JB-17200083 O-ring	1	28B	JB-19000115 Collar spring	1
6	JB-21200008 Mechanical seal (opt. buna-n)	1	28C	JB-14000021 Collar	1
	JB-21200009 Mechanical seal (std viton)	1	29	JB-05039400 Shaft (1" solid)	1
	JB-21200032 Mechanical seal (opt. silicone carbide)	1	30	JB-31150034 Driven pulley (5/8" dia. bore)	1
7	JB-18300040 Seal retainer	1	31	JB-22300003 Set screw for driven pulley	2
8	JB-14100056 Slinger ring	1	32	JB-07069400C Idler bracket (cast iron pumps)	1
9	JB-07509200C Mounting flange	1	33	JB-24050003 Grease Zerk fitting	1
10	JB-60310252 Nameplate (specify model number)	1	34	JB-18100036 Retaining ring (idler bracket, cast iron)	1
11	JB-22100020 Bolt	4	35	JB-31150036 Idler pulley	1
12	JB-20000010 Ball bearing	3	36	JB-14100095 Spacer (idler pulley)	1
13	JB-16100015 Key	1	37	JB-18200013 Retaining ring (idler pulley)	1
14	JB-05019200 Pump shaft	1	38	JB-19000156 Torsion spring (idler for cast iron)	1
15	JB-16100004 Key	1	39	JB-22100111 Idler bolt / shaft	1
16	JB-18200013 Bearing retainer	1	40	JB-28400075 Belt shield	1
17	JB-17000100 Gasket	1	41	JB-28400076 Belt shield	1
18	JB-07039400D Pedestal bracket	1	42	JB-15200062 Bracket for belt shield	1
19	JB-20010006 Driver shaft bearings	2	43	JB-22100021 Attachment bolt for shield	1
20	JB-18100012 Driver shaft bearing retainer ring	1	44	JB-22400017 Assembly bolts for shield	4
21	JB-14100094 Bearing spacer	1	45	JB-22520002 Assembly nuts for shield	4
22	JB-28400053 End cap (label)	1	46	JB-31000006 Poly V-belt (540 rpm)	1
23	JB-18200032 Bearing bore retaining ring	1		JB-31000005 Poly V-belt (1000 rpm)	1
24	JB-31150031 Driver pulley (540 rpm)	1	47	JB-2210-0055 Bolts for pump to bracket	2
24	JB-31150032 Driver pulley (1000 rpm)	1	48	JB-2260-0006 Lock washers for bracket bolts	2
24	JB-31150033 Driver pulley (540 rpm, 1 3/4" shaft)	1	49	JB-16000070 Roll pin	2
25	JB-16100033 Key (driver pulley)	1			
	JB-16100034 Key (driver pulley, 1 3/4" shaft)	1			
26	JB-18100031 Retaining ring (driver pulley)	1			
	JB-18100032 Retaining ring (driver pulley, 1 3/4" shaft)	1			

REPAIR KIT N° JB-34300477 FOR 1000 RPM DRIVES

REF NO	DESCRIPTION	Q
46	JB-31000005 Poly V-belt (1000 rpm)	1
5	JB-17200083 O-ring	1
6	JB-21200009 Mechanical seal (standard viton)	1
17	JB-17000100 Gasket	1

REPAIR KIT N° JB-34300332 FOR SEAL, O-RING

REF NO	DESCRIPTION	Q
6	JB-21200009 Mechanical seal (standard viton)	1
5	JB-17200083 O-ring	1
17	JB-17000100 Gasket	1

REPAIR KIT N° JB-34300476 FOR 540 RPM DRIVES

REF NO	DESCRIPTION	Q
46	JB-31000006 Poly V-belt (540 rpm)	1
5	JB-17200083 O-ring	1
6	JB-21200009 Mechanical seal (standard viton)	1
17	JB-17000100 Gasket	1

SILICONE CARBIDE REPAIR KIT N° JB-34300589 FOR SEAL, O-RING

REF NO	DESCRIPTION	Q
6	JB-21200032 Mechanical seal (opt. silicone carbide)	1
5	JB-17200083 O-ring	1
17	JB-17000100 Gasket	1

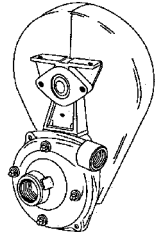

SERIES 9403C
Cast Iron Belt-Driven
Centrifugal Pump

Max. Flow rate: 84-140 GPM
 Max. Pressure: 95-104 PSI
 Max. speed: 600 and 1000 rpm
 Ports: 1 1/4" or 1 1/2" NPT inlet
 1" or 1 1/4" NPT outlet

Performance data for cast iron, self priming models									
RPM	GPM at 10 PSI	GPM at 20 PSI	GPM at 30 PSI	GPM at 40 PSI	GPM at 50 PSI	GPM at 60 PSI	GPM at 70 PSI	GPM at 80 PSI	GPM at 90 PSI
500	114	113	101	83	60	27			
540	120	119	116	102	85	62	32		
600	121	121	120	119	110	97	78	54	24

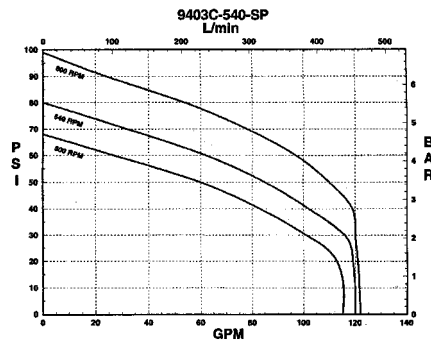

Performance data for cast iron and Poly, belt driven models • JB-9403C 1000 RPM									
RPM	GPM at 20 PSI	GPM at 30 PSI	GPM at 40 PSI	GPM at 50 PSI	GPM at 60 PSI	GPM at 70 PSI	GPM at 80 PSI	GPM at 90 PSI	GPM at 100 PSI
800	115	106	96	80	56				
900	129	127	120	111	98	80	50		
1000	140	139	137	133	128	119	100	76	46

Performance data for cast iron and Poly, belt driven models • JB-9403C 540 RPM									
RPM	GPM at 20 PSI	GPM at 30 PSI	GPM at 40 PSI	GPM at 50 PSI	GPM at 60 PSI	GPM at 70 PSI	GPM at 80 PSI	GPM at 90 PSI	GPM at 100 PSI
450	107	99	86	50					
500	121	116	106	93	76	42			
540	129	127	120	111	98	80	50		
600	140	138	135	130	121	112	94	73	40

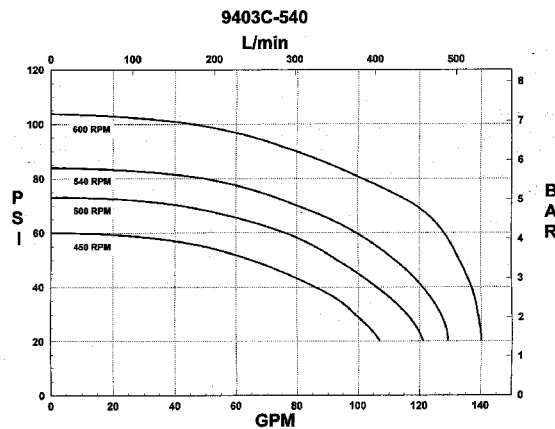

Débit : 32 gal/min
 Pression : 290 lb/po²
 Rotation : 550 r/min
 Flow rate : 32 GPM
 Pressure : 290 PSI
 Rotation: 550 RPM

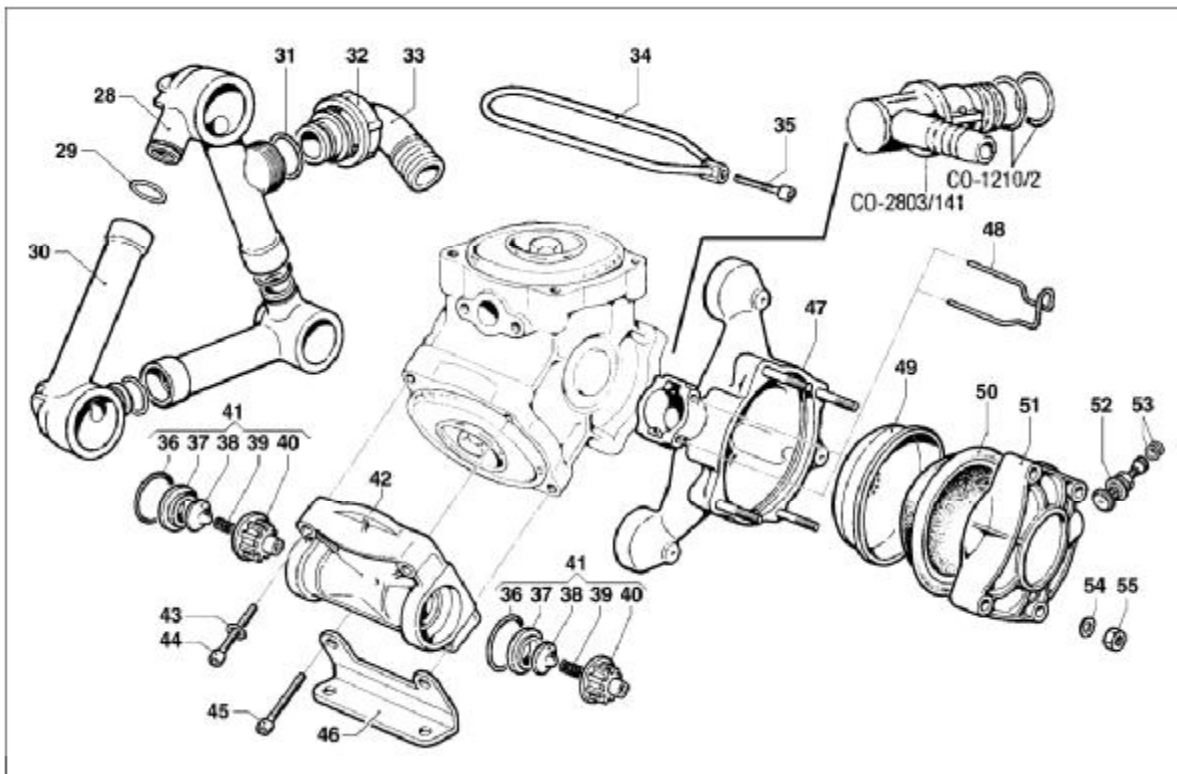
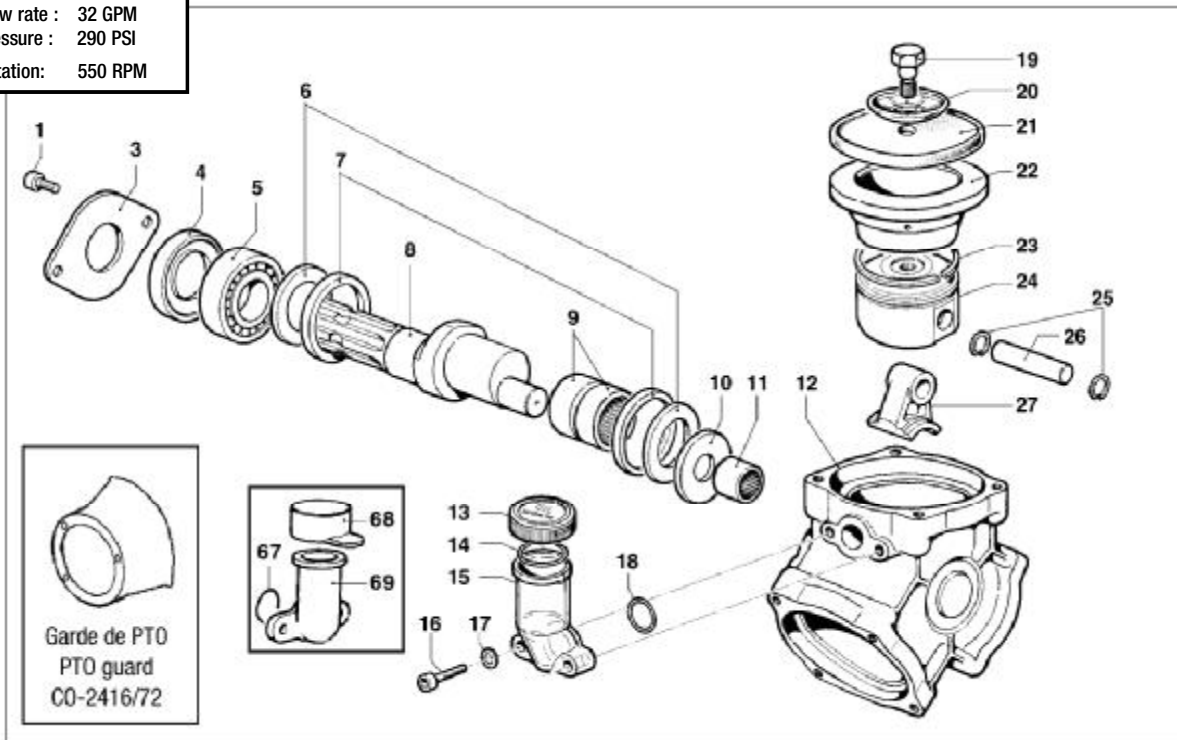

Ref	No MS	No Comet	Description	Note	Qty
1	CO-3609/171	3609 0171	Screw	M10x16	2
3	CO-1004/13	1004 0013	Flange		1
4	CO-19/10	0019 0010	Oil Seal	Ø35x62x10	1
5	CO-438/15	0438 0015	Ball Bearing	Ø35x62x14	1
6	CO-2813/19	2813 0019	Connecting Rod Washer	Ø63x40x2,8	2
7	CO-10/8	0010 0008	Connecting Rod Ring	Ø68x55x6	2
8	CO-1/382	0001 0382	NON-Throughshaft	1"3/8 M	1
9	CO-437/45	0437 0045	Bearing	Ø40x47x16	2
10	CO-2813/24	2813 0024	Connecting Rod Washer	Ø20x50x3	1
11	CO-437/33	0437 0033	Roller Bearing	Ø20x28x23	1
12	CO-403/133	0403 0133	Pump Crankcase		1
13	CO-402/141	0402 0141	Volum. Compensator Cover		1
14	CO-1210/122	1210 0122	O-Ring Ø2,62x44,12		1
15	CO-421/20	0421 0020	Volumetric Compensator		1
16	CO-3609/165	3609 0165	Screw	M8x35	2
17	CO-2811/99	2811 0099	Washer	Ø8,4x15x1,6	2
18	CO-1210/37	1210 0037	O-Ring	Ø2,5x25	1
19	CO-3605/5	3605 0005	Diaphragm Holder Screw		3
20	CO-602/45	0602 0045	Disc		3
21	CO-1800/2	1800 0002	Diaphragm Buna	Ø112	3
	CO-1800/176	1800 0176	Diaphragm Desmo		3
22	CO-400/77	0400 0077	Piston Sleeve	Ø75	3
23	CO-20/9	0020 0009	Compression Ring		3
24	CO-2409/81	2409 0081	Piston	Ø75	3
25	CO-3020/1	3020 0001	Inner Seeger	Ø15	6
26	CO-3011/1	3011 0001	Gudgeon Pin	Ø15x53	3
27	CO-205/34	0205 0034	Connecting Rod Assembly		1
28	CO-3212/23	3212 0023	Suction Hose		1
29	CO-1210/47	1210 0047	O-Ring	Ø2,62x22,22	3

Ref	No MS	No Comet	Description	Note	Qty
30	CO-3212/12	3213 0012	Suction Pipe		2
31	CO-1210/34	1210 0034	O-Ring	Ø3,53x28,17	1
32	CO-1200/11	1200 0011	Wing Nut		1
33	CO-2801/63	2801 0063	Suction Elbow Tail	Ø25x40	1
34	CO-418/41	0418 0041	U-Bolt		3
35	CO-3609/160	3609 0160	Screw	M10x30	3
36	CO-1210/419	1210 0419	O-Ring	Ø6x37x49	6
37	CO-3009/22	3009 0022	Suction/Delivery Valve Seat		6
38	CO-3604/9	3604 0009	Suction/Delivery Valve		6
39	CO-1802/15	1802 0015	Spring (Wire Ø0,8)	Øe11x17	6
40	CO-1205/4	1205 0004	Suct./Delivery Valve Cage		6
41	CO-1220/6	1220 0006	Suct./Delivery Valve Ass.y Kit		6
42	CO-3218/123	3218 0123	Pump Manifold		3
43	CO-2811/98	2811 0098	Washer	Ø10,5x18x2	7
44	CO-3609/161	3609 0161	Screw	M10x45	8
45	CO-3609/161	3609 0161	Screw	M10x45	4
46	CO-2400/87	2400 0087	Pump Mounting Bracket		2
47	CO-2/21	0002 0021	Pressure Accumulator		1
48	CO-1202/17	1202 0017	Delivery Hook		1
49	CO-460/5	0460 0005	Diaphragm Support Cap		1
50	CO-1800/34	1800 0034	Diaphragm		1
51	CO-3/30	0003 0030	Pressure Accumulator		1
52	CO-3610/3	3610 0003	Air Valve		1
53	CO-1209/3	1209 0003	Gasket	Ø14x7,5x2	2
54	CO-2811/98	2811 0098	Washer	Ø10,5x18x2	4
55	CO-604/105	0604 0105	Nut		4
67	CO-1210/37	1210 0037	O-Ring	Ø2,5x25	1
68	CO-1800/24	1800 0024	Volum. Comp. Diaphragm		1
69	CO-421/6	0421 0006	Volumetric Compensator		1

- CO-6100/3

1"3/8 Quick Coupling Torque Arm and Chain

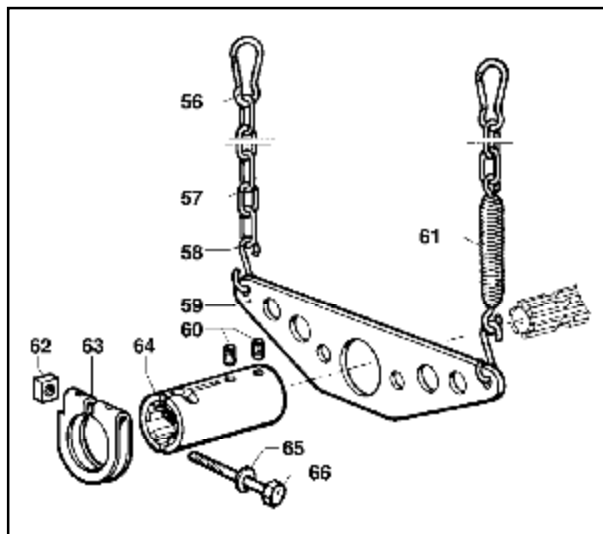

Ref	No MS	No Comet	Description	Note	Qty
56	CO-1202/9	1202 0009	Hook		2
57	CO-465/1	0465 0001	Chain	500 mm	2
58	CO-1202/6	1202 0006	Hook	Ø6	2
59	CO-3221/1	3221 0001	Torque Arm for Quick Coupling		1
60	CO-3622/11	3622 0011	Screw	M8x10	2
61	CO-1802/40	1802 0040	Spring (Wire Ø2,5) + Hook	Øe20x100	1
62	CO-600/37	0600 0037	Special Bolt	M12x6	1
63	CO-417/5	0417 0005	Collar		1
64	CO-1407/6	1407 0006	Quick Coupling	Ø1"3/8	1
65	CO-2811/25	2811 0025	Washer	Ø13x20x2,5	1
66	CO-3607/115	3607 0115	Hexagonal Screw	M12x75	1

CO-BP125GB

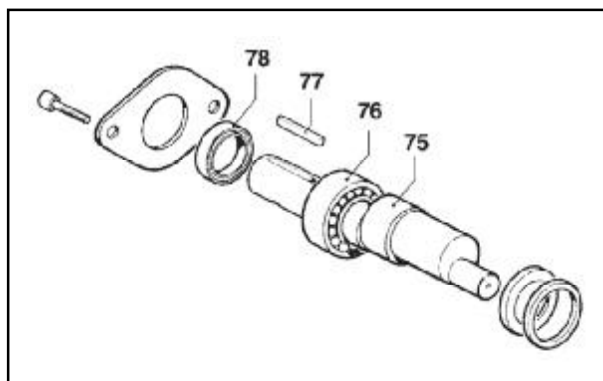

Ref	No MS	No Comet	Description	Note	Qty
75	CO-1/394	0001 0394	Non-Throughshaft	Ø30	1
76	CO-438/16	0438 0016	Ball bearing	Ø30x62x16	1
77	CO-1602/18	1602 0018	Key	8x7x40	1
78	CO-19/101	0019 0101	Oil seal	Ø30x62x7	1

Débit : 44.4 gal/min
 Pression : 290 lb/po²
 Rotation : 550 r/min
 Flow rate : 44.4 GPM
 Pressure : 290 PSI
 Rotation : 550 RPM

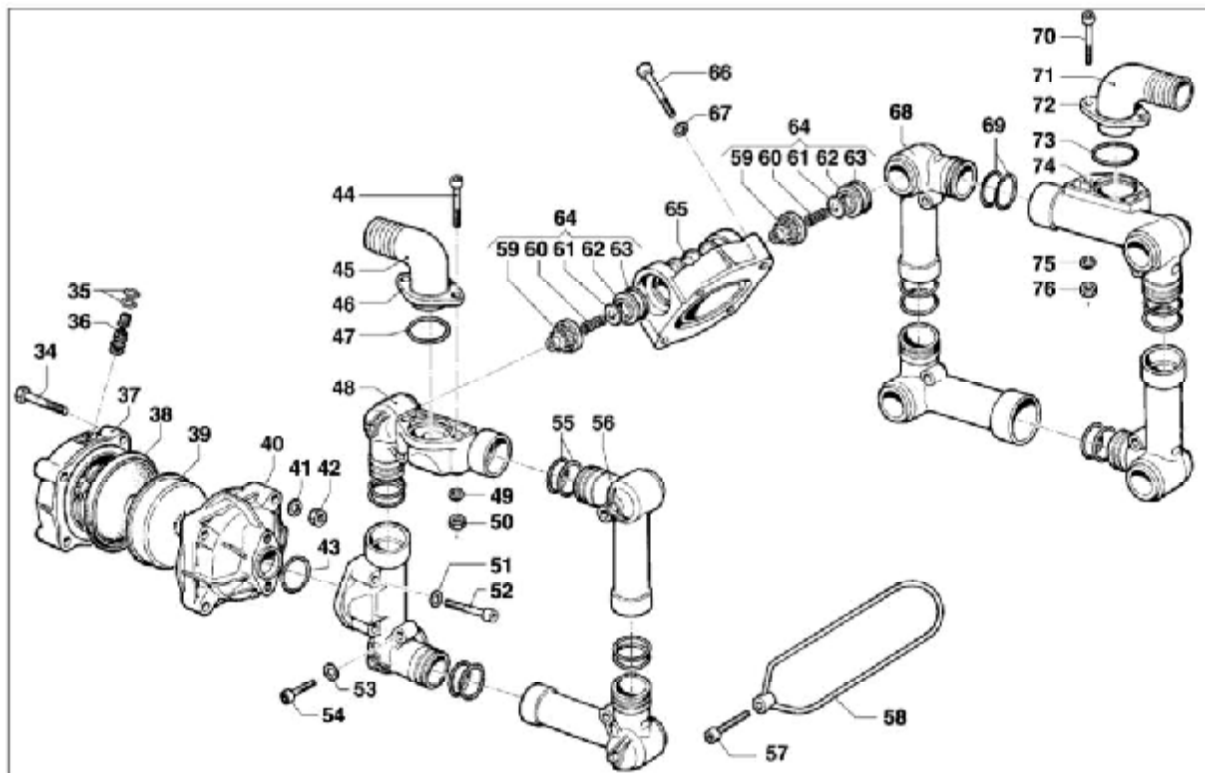
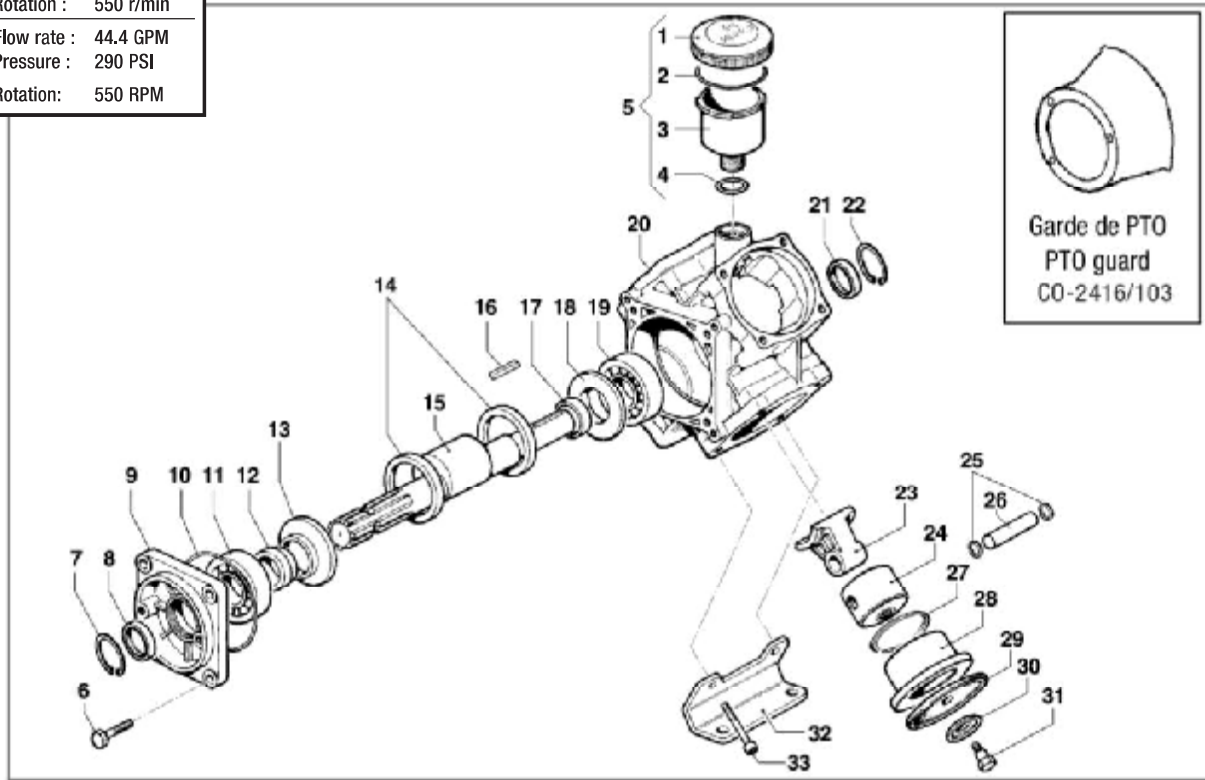

Ref	No MS	No Comet	Description	Note	Qty	Ref	No MS	No Comet	Description	Note	Qty
1	CO-402/143	0402 0143	Volum. Compensator Cover		1	39	CO-460/5	0460 0005	Diaphragm Support Cap		1
2	CO-1210/3/3	1210 0373	O-Ring	Ø3,53x73,03	1	40	CO-2/24	0002 0024	Pressure Accumulator		1
3	CO-421/12	0421 0012	Volumetric Compensator		1	41	CO-2811/98	2811 0098	Washer	Ø10,5x18x2	4
4	CO-1210/2	1210 0002	O-Ring	Ø2,62x20,7	1	42	CO-604/105	0604 0105	Nut	M10	4
5	CO-1208/15	1208 0015	Volumetric Compensator		1	43	CO-1210/185	1210 0185	O-Ring	Ø4,0x38	1
6	CO-3607/220	3607 0220	Hexagonal Screw	M10x30	4	44	CO-3609/156	3609 0156	Screw	M8x55	2
7	CO-3020/9	3020 0009	Inner Seeger	Ø47	1	45	CO-2801/32	2801 0032	Elbow Coupling	Ø25	1
8	CO-19/83	0019 0083	Oil Seal	Ø35x47x7	1	46	CO-2404/108	2404 0108	Hose Tail Fixing Plate	1	1
9	CO-405/67	0405 0067	Support Cover		1	47	CO-1210/180	1210 0180	OR O-Ring	Ø3x29	1
10	CO-1210/345	1210 0345	O-Ring	Ø1,78x101,32	1	48	CO-3214/39	3214 0039	Delivery Hose		2
11	CO-438/12	0438 0012	Ball Bearing	Ø35x80x21	1	49	CO-2811/99	2811 0099	Washer	Ø8,4x15x1,6	4
12	CO-601/132	0601 0132	Spacer	Ø35xØ48x18	1	50	CO-604/107	0604 0107	Nut	M8	2
13	CO-2813/36	2813 0036	Connecting Rod Washer		1	51	CO-2811/99	2811 0099	Washer	Ø8,4x15x1,6	1
14	CO-10/20	0010 0020	Connecting Rod Ring	Ø80x68	2	52	CO-3609/156	3609 0156	Screw	M8x55	2
15	CO-1/402	0001 0402	Throughshaft	1"3/8-Ø30 Cil.	1	53	CO-2811/99	2811 0099	Washer	Ø8,4x15x1,6	1
16	CO-1602/18	1602 0018	Key	8x7x40	1	54	CO-3609/162	3609 0162	Screw	M8x40	4
17	CO-601/134	0601 0134	Spacer	Ø35xØ44x10	1	55	CO-1210/11	1210 0011	O-Ring	Ø3,0x36	8
18	CO-2813/36	2813 0036	Connecting Rod Washer		1	56	CO-3214/38	3214 0038	Delivery Hose		2
19	CO-438/12	0438 0012	Ball Bearing	Ø35x80x21	1	57	CO-3609/163	3609 0163	Screw	M10x40	4
20	CO-403/118	0403 0118	Pump Crankcase		1	58	CO-418/40	0418 0040	U-Bolt		4
21	CO-19/83	0019 0083	Oil Seal	Ø35x47x7	1	59	CO-1205/34	1205 0034	Suction/Delivery Valve Cage		8
22	CO-3020/9	3020 0009	Inner Seeger	Ø47	1	60	CO-1802/71	1802 0071	Spring (Wire Ø1)	Øe21x22	8
23	CO-205/38	0205 0038	Connecting Rod Assembly		1	61	CO-3604/9	3604 0009	Suction/Delivery Valve		8
24	CO-2409/81	2409 0081	Piston	Ø75	4	62	CO-3009/22	3009 0022	Suction/Delivery Valve Seat		8
25	CO-3020/1	3020 0001	Inner Seeger	Ø15	8	63	CO-1210/419	1210 0419	O-Ring	Ø6x37x49	8
26	CO-20/9	0020 0009	Compression Ring		4	64	CO-1220/46	1220 0046	Suct./Delivery Valve Ass.y kit		8
27	CO-3011/1	3011 0001	Gudgeon Pin	Ø15x53	4	65	CO-3218/123	3218 0123	Pump Manifold		4
28	CO-400/77	0400 0077	Piston Sleeve	Ø75	4	66	CO-3609/161	3609 0161	Screw	M10x45	12
29	CO-1800/2	1800 0002	Diaphragm Buna	Ø112	4	67	CO-2811/98	2811 0098	Washer	Ø10,5x18x2	11
	CO-1800/176	1800 0176	Diaphragm Desmo		4	68	CO-3214/38	3214 0038	Delivery Hose		3
30	CO-602/45	0602 0045	Disc		4	69	CO-1210/11	1210 0011	O-Ring	Ø3,0x36	8
31	CO-3605/5	3605 0005	Diaphragm Holder Screw	M12x1,5	4	70	CO-3609/156	3609 0156	Screw	M8x55	2
32	CO-2400/64	2400 0064	Pump Mounting Bracket		2	71	CO-2801/55	2801 0055	Elbow Coupling	Ø40	1
33	CO-3609/161	3609 0161	Screw	M10x45	4	72	CO-2404/108	2404 0108	Hose Tail Fixing Plate		1
34	CO-3607/223	3607 0223	Hexagonal Screw	M10x65	4	73	CO-1210/180	1210 0180	O-Ring	Ø3x29	1
35	CO-1209/33	1209 0033	Gasket	Ø14x7,5x2	2	74	CO-3214/39	3214 0039	Delivery Hose		1
36	CO-3610/3	3610 0003	Air Valve		1	75	CO-2811/99	2811 0099	Washer	Ø8,4x15x1,6	4
37	CO-3/30	0003 0030	Pressure Accumulator		1	76	CO-604/107	0604 0107	Nut	M8	2
38	CO-1800/34	1800 0034	Diaphragm Buna		1						

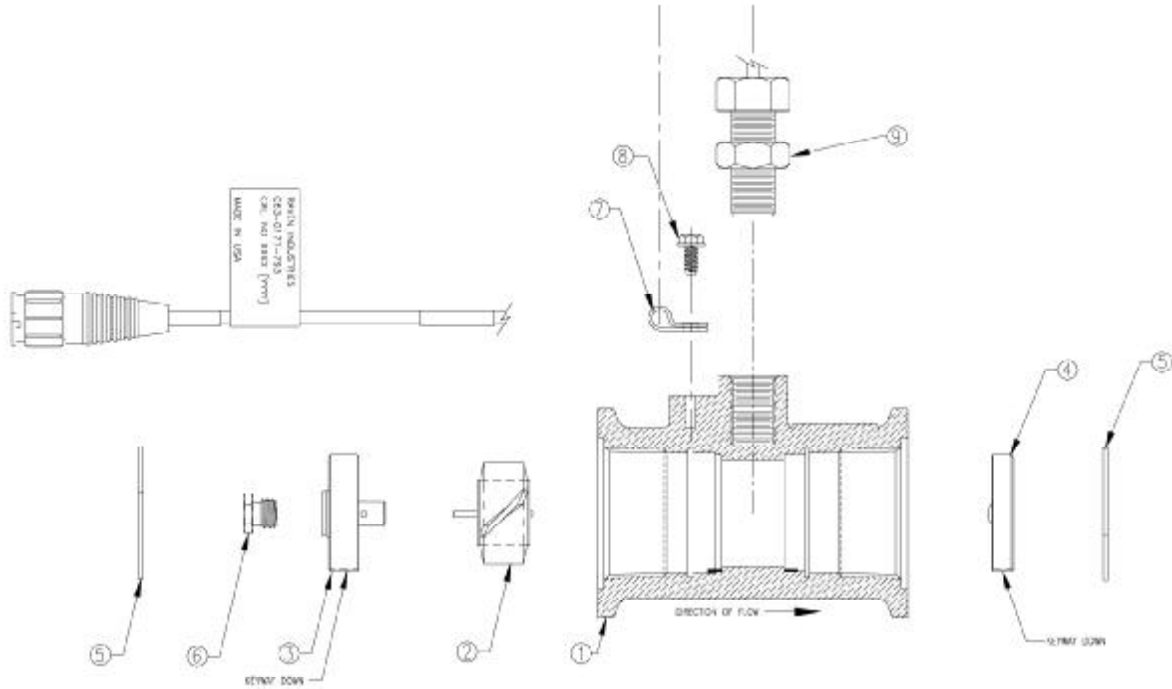

REF N°	DESCRIPTION
1	RA-1060159514 Body RFM 60s Flow Meter
2	RA-0630171673 Rotor/Magnet Assembly
3	RA-0630171674 Hub/Bearing Assembly, Upstream
4	RA-0630171769 Hub, Assembly, Downstream
5	RA-3350000278 Ring, Retaining internal
6	RA-0630159570 Stud Bearing
7	RA-4353302017 Clamp Cable
8	RA-3100002137 Screw, Thread Forming
9	RA-0630171669 Sensor, assembly, External

Ensemble de contrôles électriques • Electrical switch boxes assembly **MP-46625...**

Ajouter le préfixe "MP" avant le # de pièce, ex : MP-V2B26G
 Add the "MP" prefix before the part #, ex : MP-V2B26G

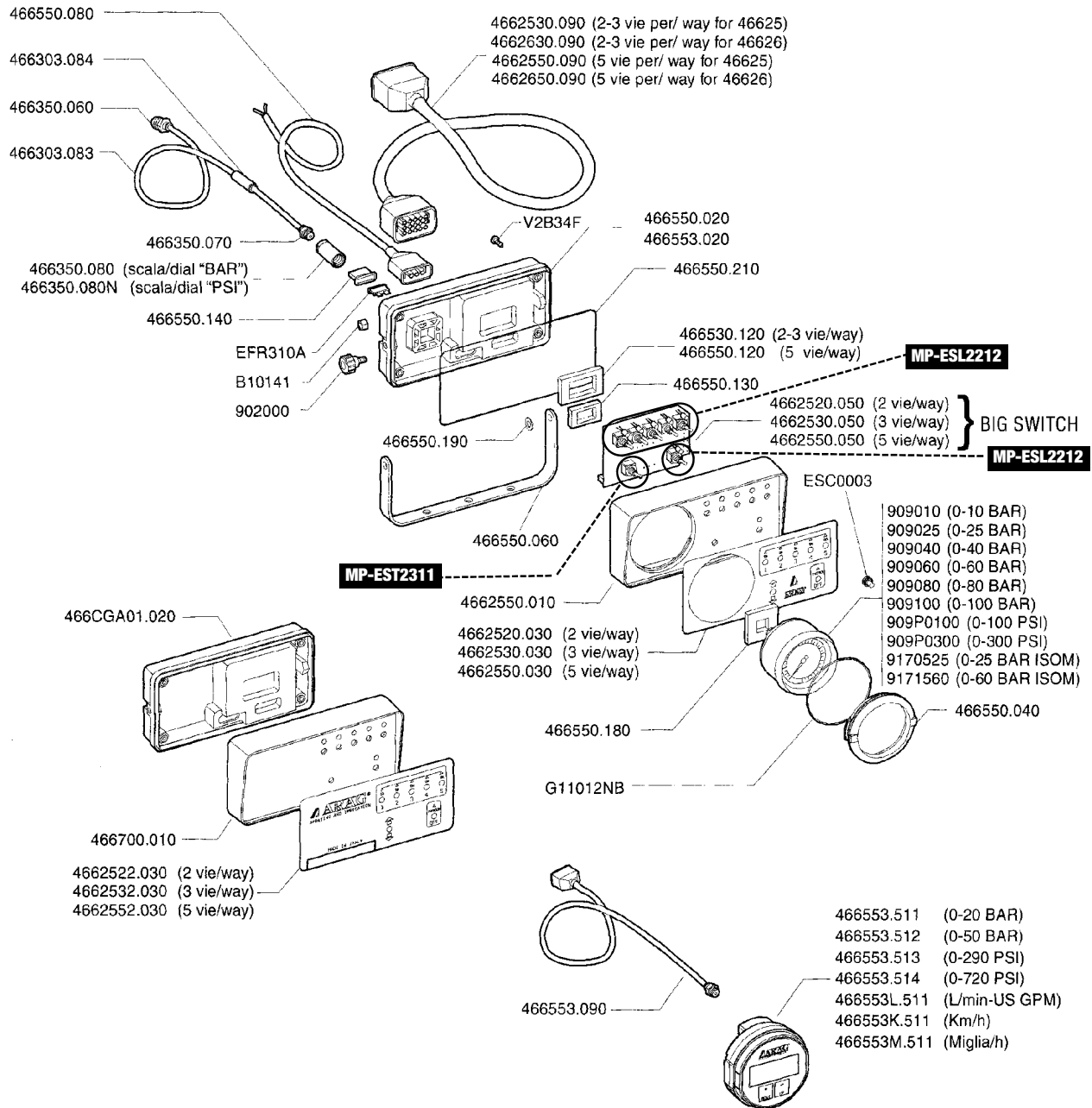

**ELECTRICAL SWITCH BOX
BOÎTE DE COMMANDES ÉLECTRIQUES**

Cod. 466520 - 466521

Cod. 466530 - 466531

Cod. 466550 - 466551

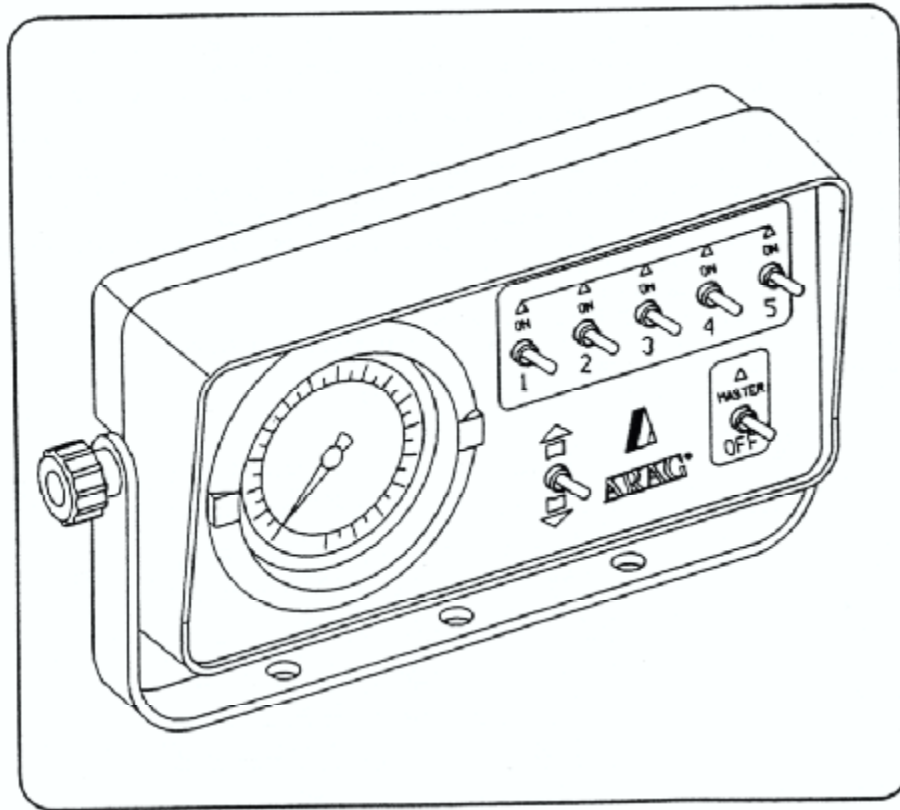

MISURE D'INGOMBRO - SIZES

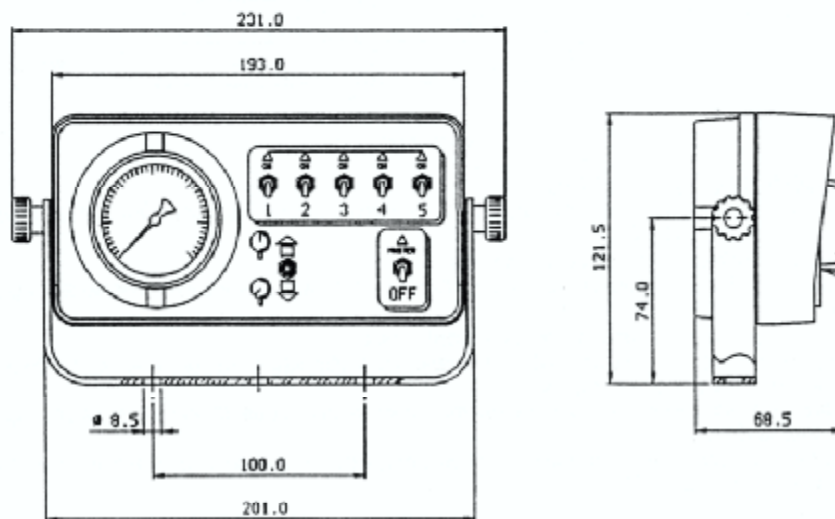

FRANÇAIS**CABLAGE**

- Raccordez le fil marron du câble d'alimentation (A) à un point du circuit ayant une tension de 12V, si possible en aval de l'interrupteur à clé, qui est en mesure de débiter un courant d'au moins 8 A.
- Raccordez le fil bleu du câble d'alimentation au châssis; assurez-vous que le point d'ancrage choisi ait une bonne continuité électrique avec le pôle négatif de la batterie.
- Effectuez toutes les connexions comme indiqué dans la figure, en utilisant des bômes à vis ou des cosses; vérifiez que les raccordements sont stables pour éviter que les vibrations provoquent de faux contacts.
- Protégez les connexions entre le câble de la boîte de commande et les fils des électrovannes par un boîtier de dérivation (code 466010, comprenant aussi les bômes et les serre-câbles).
- Enduisez le filet du manomètre, sortant à l'arrière du boîtier, d'une mince couche de colle en faisant attention à ne pas boucher l'orifice d'entrée du manomètre
- Vissez la réduction (F) sur le filet du manomètre
- Vissez le raccord rapide fileté 1/8" (E) sur la réduction
- Vissez le raccord rapide 1/4" (C) à l'endroit où vous désirez, contrôler la pression
- Introduisez le, tuyau (D) dans les deux raccords
- Coupez le tuyau à la bonne distance et introduisez le joint (B)

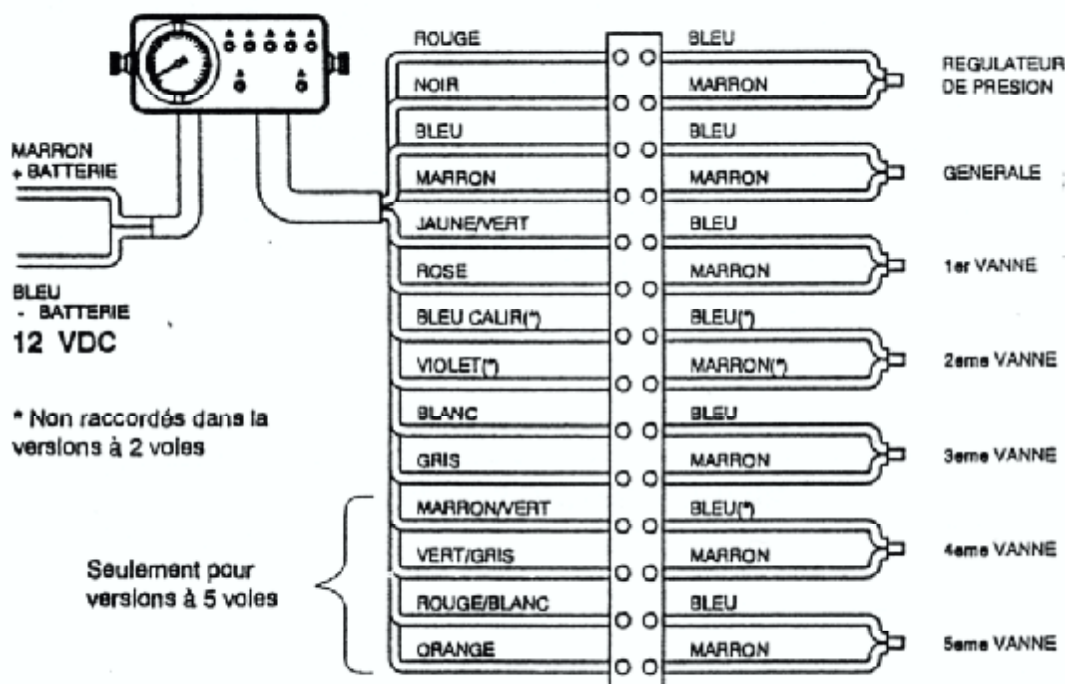
**ENTRETIEN****REPLACEMENT DU MANOMETRE**

- Débranchez le tube de liaison du manomètre (D) du raccord à branchement rapide 1/8" (E) en maintenant appuyé l'anneau de ce dernier.
- Dévissez la réduction (F) du filet du manomètre.
- Appuyez et simultanément tournez l'anneau de fixation (L) de 90° dans le sens renverse aux aiguilles d'une montre.
- Enlevez le manomètre en appuyant sur le raccord arrière.
- Otez le joint (I) placé dans la partie arrière du manomètre démonté et montez-le sur le manomètre neuf.
- Introduisez le manomètre neuf dans le boîtier
- Introduisez l'anneau de fixation, appuyez et simultanément tournez de 90° dans le sens des aiguilles d'une montre pour le fixer.
- Revissez la réduction sur le filet du manomètre en utilisant de la colle et en faisant attention à ne pas boucher l'orifice d'entrée du manomètre.

REPLACEMENT DU FUSIBLE

- Enlevez le capuchon du fusible (G)
- Enlevez le fusible (H)
- Introduisez le fusible neuf en exerçant une légère pression, jusqu'à ce qu'il arrive en fin de course
- Remettez le capuchon du fusible

REPLACEMENT D'UN OU DE PLUSIEURS INTERRUPTEURS

- Enlevez le capuchon du fusible (G)
- Découvrez les connecteurs en faisant glisser les capuchons des 2 câbles de liaison
- Débranchez les câbles en maintenant les ailettes d'ancrage enfoncées.
- Dévissez les 4 vis de fixation (O) qui se trouvent sur la partie arrière du boîtier
- Dévissez les écrous de tous les interrupteurs et enlevez le circuit (N)
- Enlevez les interrupteurs en tenant le circuit.
- Montez les nouveaux interrupteurs en appuyant sur le fillet mais pas sur les leviers d'actionnement.
- Remontez tout en suivant la procédure inverse

MODIFICATION DU TYPE DE FONCTIONNEMENT DU BOITIER DES COMMANDES

Le boîtier électrique a deux types de fonctionnement:

- **Type M (standard):** quand l'interrupteur de la vanne générale est commuté en position OFF, la soupape d'échappement est actionnée et automatiquement toutes les sections sont fermées, tandis que sur la position ON, chaque section est fermée ou ouverte suivant la position des interrupteurs correspondants.
- **Type P (sur demande):** chaque section est indépendante de la position de l'interrupteur général qui actionne seulement la vanne générale.

Pour changer le fonctionnement du Type M au Type P:

- enlevez le capuchon du fusible (G)
- découvrez les connecteurs en faisant glisser les capuchons des 2 câbles de liaison
- débranchez les câbles en maintenant les ailettes d'ancrage enfoncées
- dévissez les 4 vis de fixation (O) qui se trouvent à l'arrière du boîtier
- déplacez le câble, repéré sur le circuit par le chiffre 1, de la position M1 à la position P1
- déplacez le câble, repéré sur le circuit par le chiffre 2, de la position M2 à la position P2
- remontez l'ensemble en suivant la procédure inverse

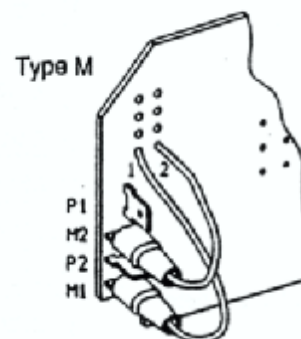
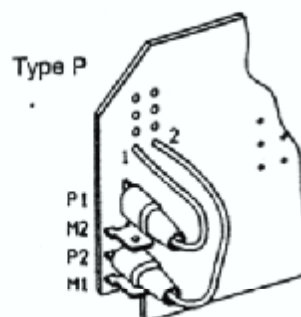

INCONVENIENTS ET REMEDES

INCONVENIENT	CAUSE	REMEDE
Les leds s'allument mais les motoréducteurs ne fonctionnent pas	Fils débranchés	Contrôlez les raccordements électriques
Les leds sont éteints et les motoréducteurs ne fonctionnent pas	Fusible brûlé Pas d'alimentation	Contrôlez le fusible (H) Contrôlez l'alimentation
Quand les interrupteurs sont sur la position OFF les leds sont allumés	Fils d'alimentation inversés	Contrôlez le raccordement des fils d'alimentation
Fuite d'eau entre réduction (F) et le fillet	La réduction n'est pas vissée correctement ou sans colle	Vissez de nouveau réduction en utilisant de la colle.
Le manomètre indique toujours une pression 0	L'orifice d'entrée du manomètre est bouché par de la colle. Manomètre défectueux	Contrôlez l'orifice d'entrée du manomètre et nettoyez-le Vérifiez le manomètre

ENGLISH

CONNECTION

- Connect the power cord's brown wire (A) to a 12 V power outlet possibly downstream from the keylock switch and able to supply current at 8 A minimum
- connect the power cord's blue wire to the chassis making sure that the fastening point chosen has excellent electric continuity with the battery's negative pole
- make all the connections as shown the Figure using the screw or terminal end terminals. Ensure that the connections are securely tightened to avoid false contacts caused by vibration
- protect the connections between the control box cable and the electrovalves wires with a junction box (Ordering code N° 466010 including terminals and wire pass throughs)
- cover the gauge's threaded section (rear side) with a light coating of sealant but be careful not to clog the gauge inlet hole
- screw the reduction fitting (F) onto the gauge's threaded section
- screw the 1/8" threaded quick coupling (E) onto the reduction fitting
- screw the 1/4" threaded quick coupling (C) at the point where you want to check the pressure
- insert the hose (D) into the two fittings
- cut this hose at the correct place and insert the coupling (B)

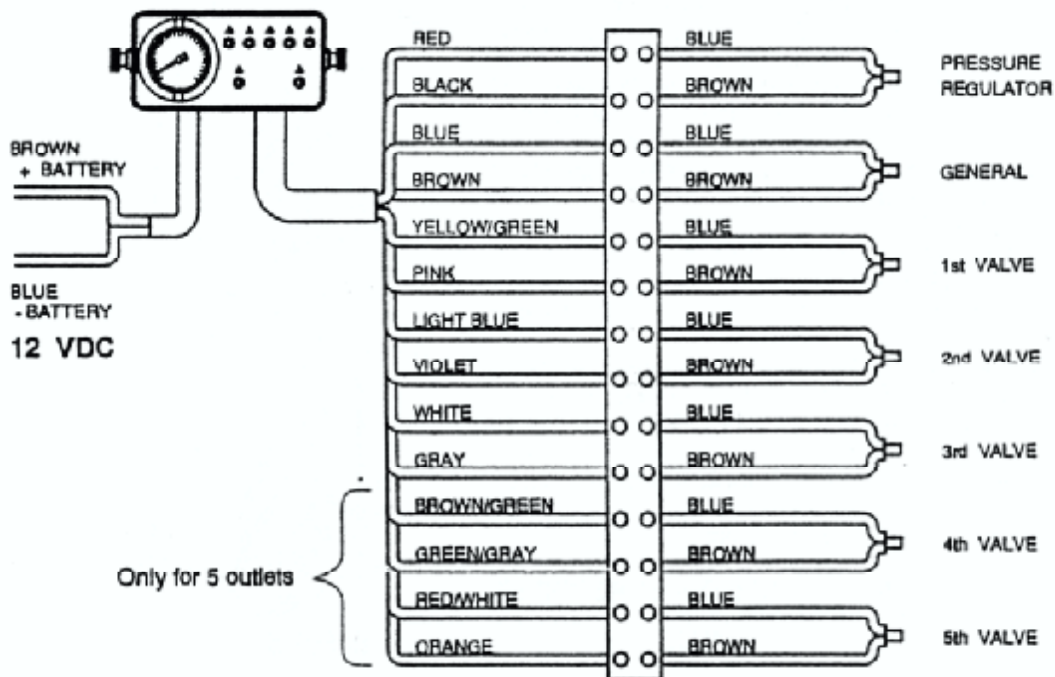

* Non connected in the 2-way version

REPAIR INSTRUCTIONS

CHANGING THE GAUGE

- Remove the gauge connecting pipe (D) from the 1/8" threaded quick coupling (E). Hold down the release button on this latter
- unscrew the reduction section (F) from the gauge's threaded section
- press down on and, at the same time, turn the fastening ring (L) 90° counter clockwise
- remove the gauge itself by pushing down on the rear coupling
- remove the gasket (I) at the back of the gauge you have just removed and push it on the new gauge
- Insert the new gauge in the box
- insert the fixing ring; push it down and at the same time turn it 90° clockwise to fasten the gauge
- screw the reduction back on the gauge's threaded section with a light coating of sealant and make sure the hole is not clogged

CHANGING THE FUSE

- Remove the fuse cap (G)
- remove the blown fuse (H)
- insert the new fuse and push gently down on it until it is all the way in
- replace the fuse cap

CHANGING ONE OR MORE SWITCHES

- Remove the fuse cap (G)
- uncover the connectors by pulling back the caps from the two connecting wires
- remove the wires by pinching back the fastening fins
- remove the 4 fastening screws (O) at the rear of the electric box
- remove the nuts from all the switches and remove the circuit board (N)
- hold the circuit board steady and remove the switches
- insert the new switches by pushing on the threaded section and not on the actuating levers
- re-assemble in reverse order

CHANGING CONTROL BOX OPERATING MODE

The electric control box has two kinds of operation:

Type M (standard): when the main switch is moved to OFF, any drain valves are actuated and all the sections are automatically closed. When the switch is on ON, the individual sections are open or closed depending on the positions of their switches

Type P (optional): the position of the individual sections is independent from that of the master switch which is therefore just the main switch

To change the operational mode from Type M to Type P:

- remove the fuse cap (G)
- uncover the connectors by pulling back the caps from the two connecting wires
- remove the wires by pinching back the fastening fins
- remove the 4 fastening screws (O) at the rear of the electric box
- move wire marked 1 on the circuit board from position M1 to P1
- move wire marked 2 on the circuit board from position M2 to P2
- re-assemble in reverse order

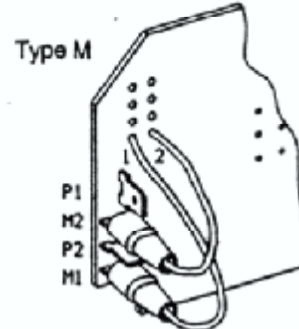
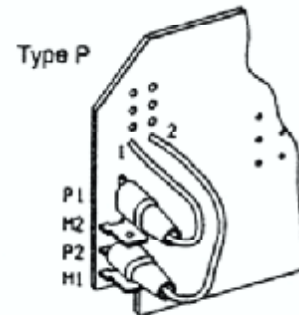

TROUBLE SHOOTING

<u>PROBLEM</u>	<u>TYPICAL CAUSE</u>	<u>REMEDY</u>
The LEDs light but geared motors do not run	Wires disconnected	Check electric connections
LEDs are out and geared motors do not run	Fuse (H) blown No power supply	Check fuse Check power supply
When switches are OFF the LEDs are lit	Supply wires switched around	Check power supply wires
Water leaks between reduction (F) and gauge threaded section	Reduction incorrectly screwed in or without sealant	Screw reduction in correctly using sealant
The gauge always reads a pressure of "0"	Gauge inlet hole is clogged by the sealant Defective gauge	Check inlet hole and clean it Check gauge

PARTS LIST			
NO	PART NUMBER	QTY	PART DESCRIPTION
1	230-056	1	BAG POLY 9 X 12 3MIL W/LOGO
2	230-095	2	CAP #3
3	232-050	2	DECL S/N (SILVER)
4	232-054	1	DECL 12V NEG WARNING
5	232-055	1	DECL GOLD/BLK 2.25 X 3.75
6	232-059	1	DECL GOLD/BLK 1.5 X .5
7	253-003	2	COIL 6354012 DD
8	270-058	1	BLOCK M10937-1 151/BP
9	273-004	2	CART SV10-41-0-N-00

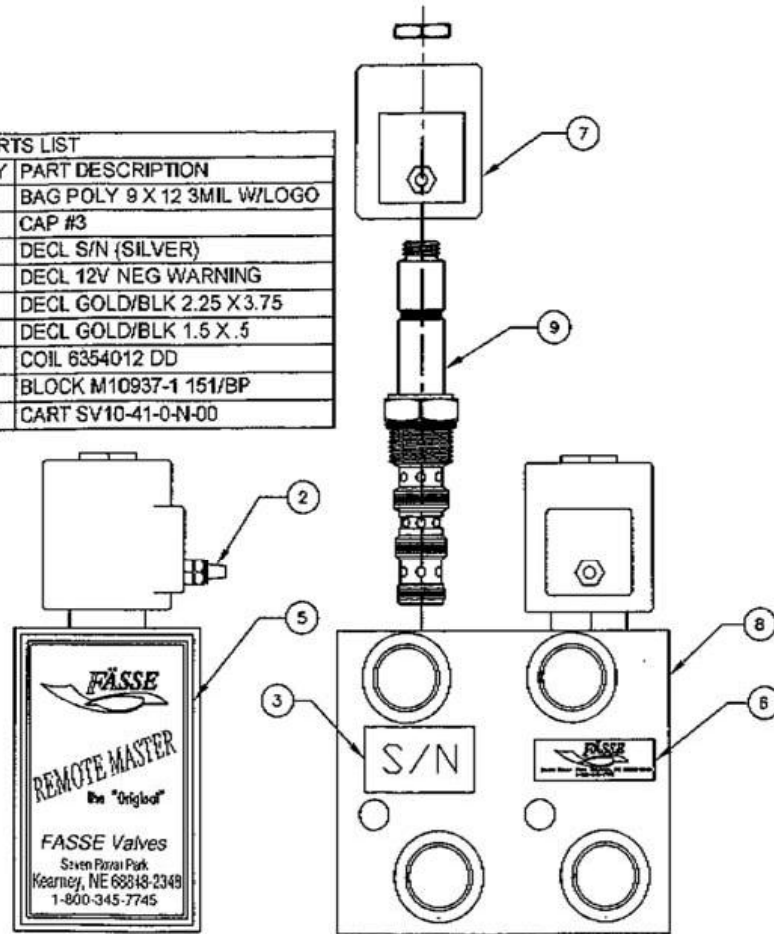

PARTS LIST

N°	PART NUMBER	QTY	PART DESCRIPTION
1	210-180	2	FTG FASSE ORBIT ECCENTRIC
2	230-080	1	BAG 6 X 8 6MIL
3	272-018	4	CPLNG FASSE ISO POPPET FEMALE
4	272-019	2	CPLNG FASSE ISO POPPET MALE TIP

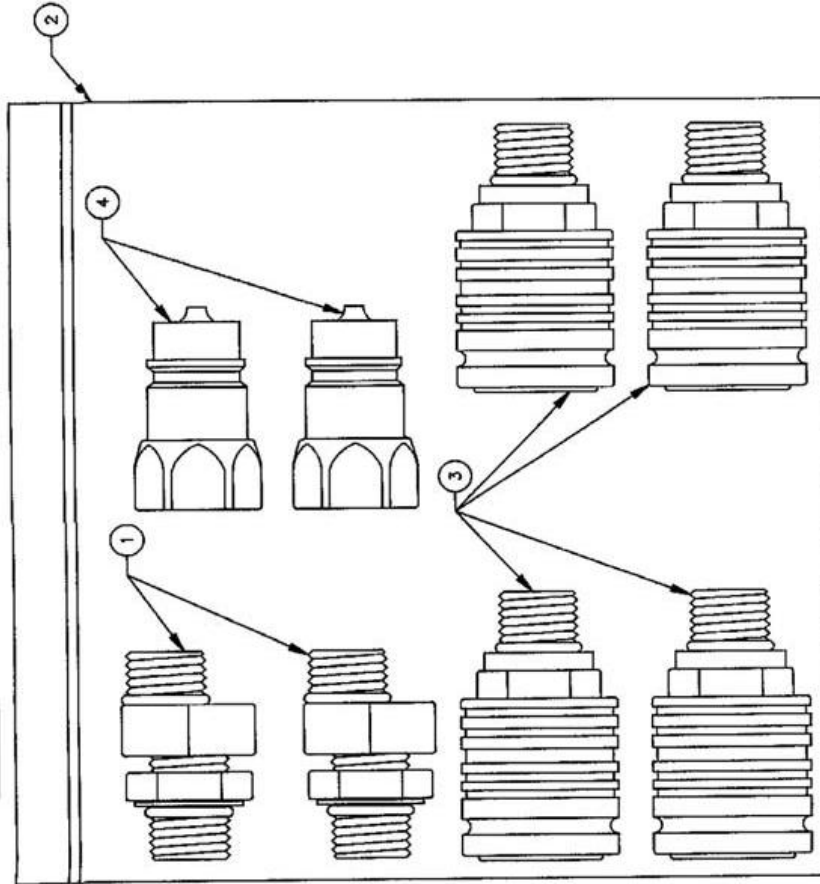

PARTS LIST

N°	PART NUMBER	QTY	PART DESCRIPTION
1	211-010	1	DUST PLUG GREEN
2	211-011	1	DUST PLUG RED
3	211-012	1	DUST PLUG YELLOW
4	211-014	1	DUST PLUG BLUE
5	211-016	1	DUST CAP GREEN
6	211-017	1	DUST CAP RED
7	211-018	1	DUST CAP YELLOW
8	211-020	1	DUST CAP BLUE
9	214-002	1	CABLE TIE BLACK 7"

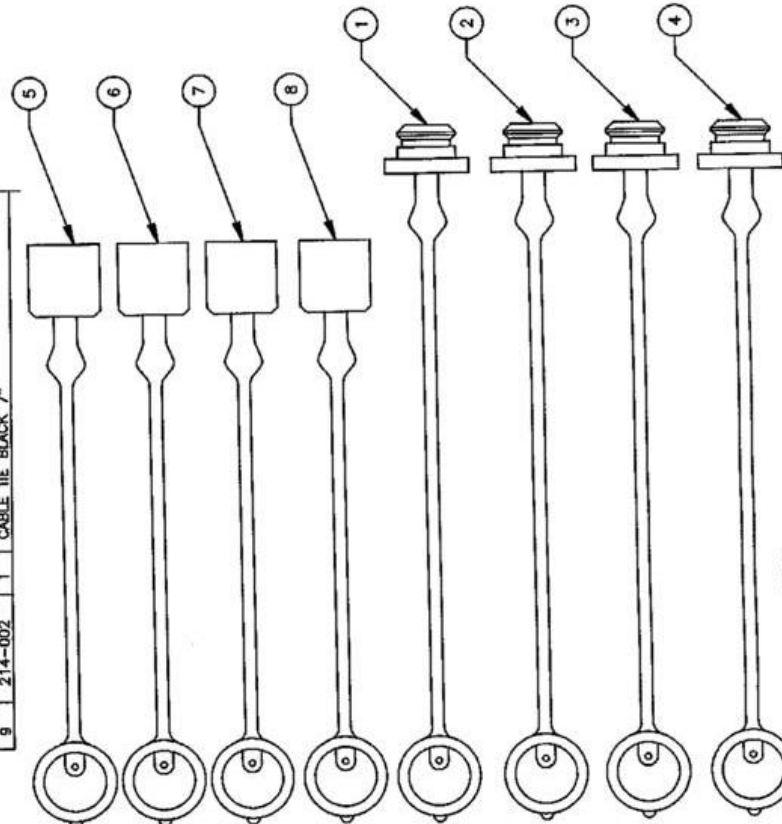

NOTE: 1. (9) NOT SHOWN.

PARTS LIST			
NR	PART NUMBER	QTY	PART DESCRIPTION
1	213-005	2	WASHER RUBBER 1"ODx1/40x1/16TK
2	214-002	13	CABLE TIE BLACK 7"
3	219-007	2	SCREW THUMB BLK 1/4-20X1/2
4	219-008	1	BRKT ALM 3.34" #1591L
5	230-055	1	BAG POLY 9 X 12 3MIL W/LOGO
6	232-050	2	DECL S/N (SILVER)
7	232-056	1	DECL GOLD/BLK 3 X 1.875
8	250-011	1	SW PB BOOT CLR
9	250-022	1	SW PB SPST STAT
10	250-023	1	SW TOG BOOT OPN GRY
11	250-043	1	SW TOG SPDT 3P STAT LONG
12	251-003	2	LAMP 12V 1/2" SNAP RED
13	255-030	1	TRM SPLICE CLOSED END
14	255-119	3	TRM PO F INS 16-14GA
15	259-001	1	GROMMET 5000D SNAP
16	259-004	1	SW TOG GRIP VNTL WHIT .187
17	300-009	1	HARNESS 2CON TB2 /13"
18	300-010	1	FUSE KIT 10 AMP
19	300-271	1	HARNESS R/B WIRE /6"
20	301-002	1	TRM KIT #1 /2BULLET
21	304-513	1	ENCL DRL 1591LEK-1X1/2S1X3/8PESK1/2

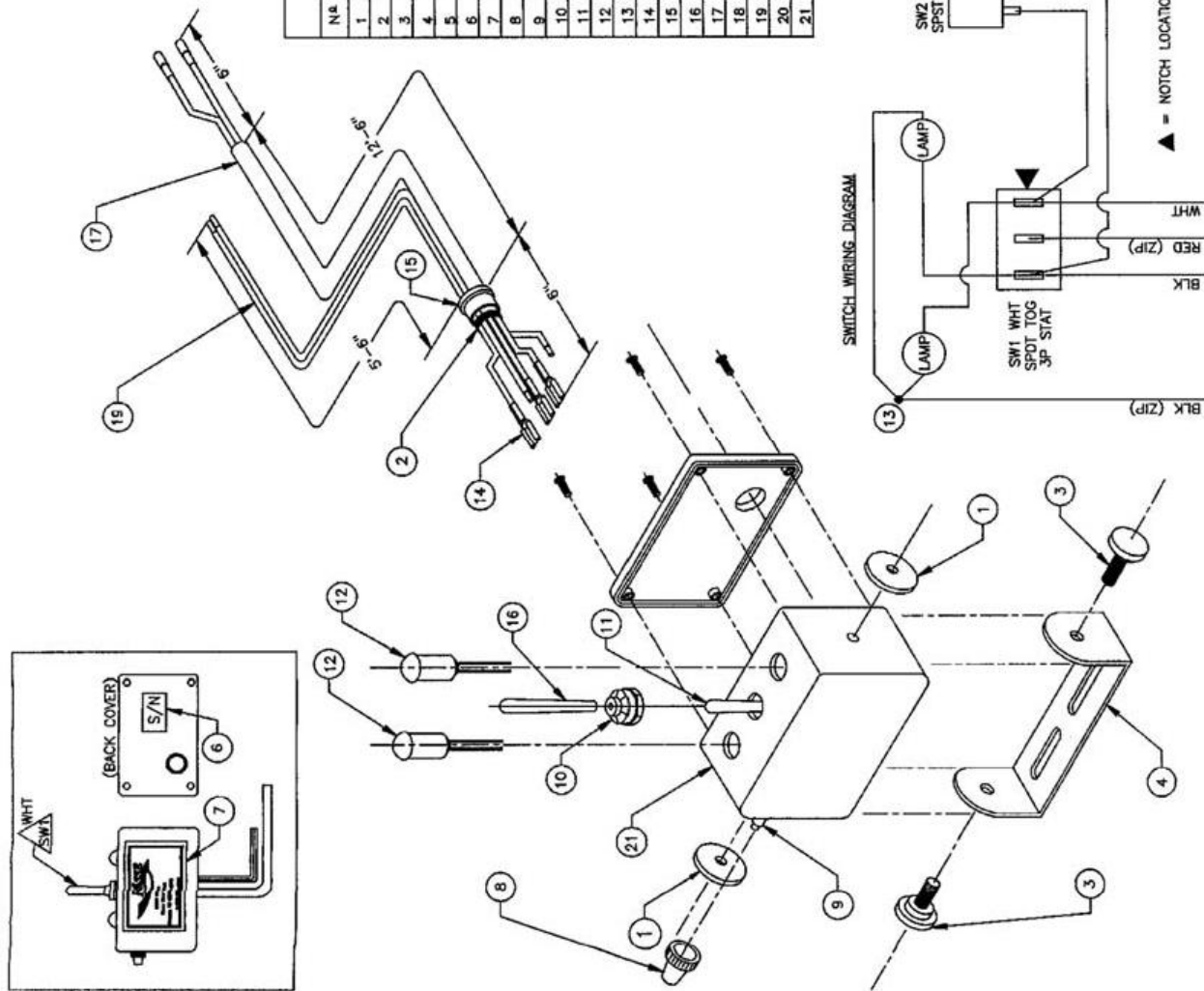

Pièces • Parts

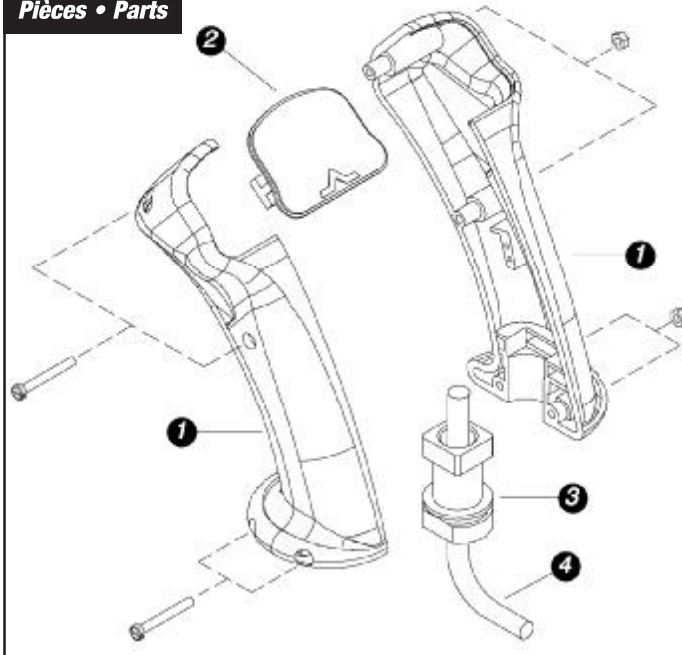

REF N°	DESCRIPTION	Q
1	HB000 Half-shell	2
2	HB000 Holder plate	1
3	ME JOINT Mounting joint	1
4	N/D Cable	

Interrupteurs • Switches

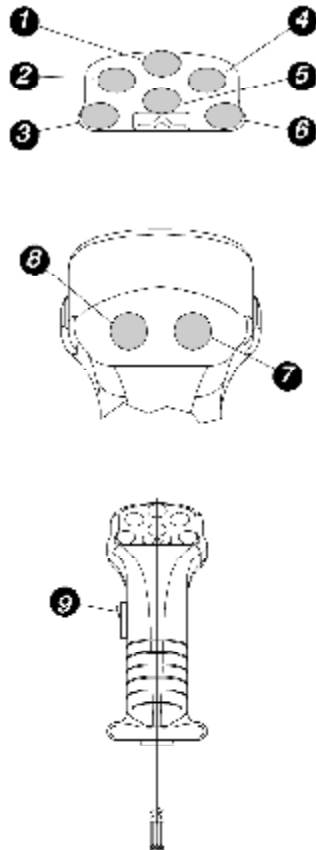

REF N°	DESCRIPTION	Q
1	B.R.H. (RED)	
2	B.B.H. (BLUE)	
3	B.V.H. (GREEN)	
4	B.B.H. (BLUE)	
5	B.Y.H. (YELLOW)	
6	B.V.H. (GREEN)	
7	B.G.H. (GRAY)	
8	B.G.H. (GRAY)	
9	CA-JOYSTSWITCH ROCKER SWITCH	

ASSEMBLY
DSG-3C4-Y-01-D24

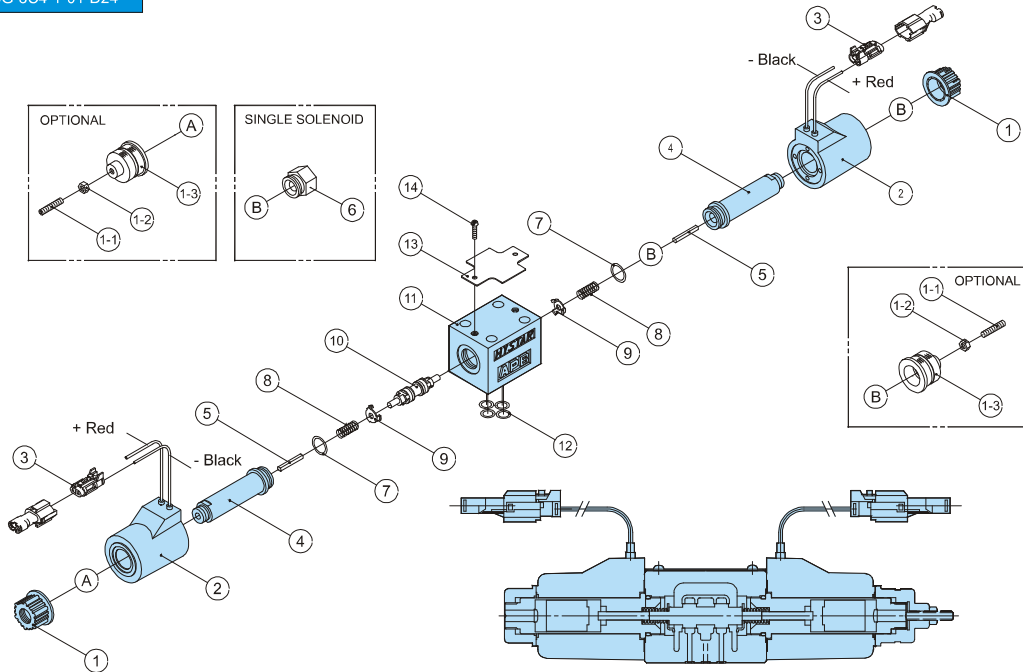

ASSEMBLY
DSG-3C2-N-01-D24

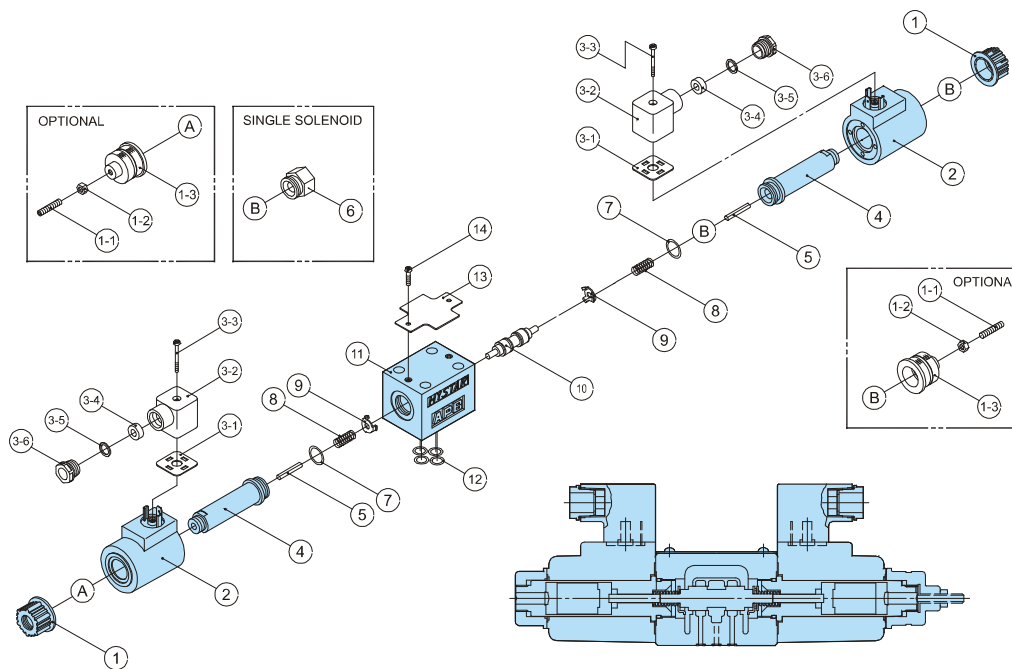



A

PARTSLIST OF "DSG-01/03-(N)" SERIES

NO	PART NAME	DSGX-01	DSG-01-AC	DSG-01-DC	DSG-03-AC	DSG-03-DC
1	Lock Nut	GX01001	G01001	G01001	G03001	G03001
2	Coil	GX01002(★)	G01002(★)	G01002(★)	G03002(★)	G03002(★)
4	Solenoid Core	GX01004	G01004A	G01004D	G03004A	G03004D
5	Push Pin	GX01005	G01005	G01005	G03005	G03005
6/B	Back Cover	GX01006	G01006	G01006	G03006	G03006
7	O-Ring	P18 x 2pcs	P18 x 2pcs	P18 x 2pcs	P21 x 2pcs	P21 x 2pcs
8	Spring	GX01008	G01008	G01008	G03008(◆)	G03008(◆)
9	Retainer	G01009	G01009	G01009	G03009	G03009
9-1	Spring stop	-----	-----	-----	G03009-1	G03009-1
10	Spool	G01010(※)	G01010(※)	G01010(※)	G03010(※)	G03010(※)
11	Body	G01011	G01011	G01011	G03011	G03011
12	O-Ring	P9 x 4pcs	P9 x 4pcs	P9 x 4pcs	P12 x 5pcs	P12 x 5pcs
16	Detent Guide	G01016	G01016	G01016	G03016	G03016
17	Detent Kit	G01017	G01017	G01017	G03017	G03017
18	Detent Hold	-----	-----	-----	G03018	G03018
A	Stroke Limiter	GX01SLA	G01SLA	G01SLA	G03SLA	G03SLA
1-1	Fixing Screw	GX01SL1	G01SL1	G01SL1	G03SL1	G03SL1
1-2	Steel Nut	GX01SL2	G01SL2	G01SL2	G03SL2	G03SL2
1-3	Lock Nut	GX01SL3	G01SL3	G01SL3	G03SL3	G03SL3

DIN CONNECTOR TYPE 'DIN 43650'

NO	PART NAME	DSGX-N-01	DSG-N-01-AC	DSG-N-01-DC	DSG-N-03-AC	DSG-N-03-DC
3	DIN Connector	43650 AC/DC	43650 AC	43650 DC	43650 AC	43650 DC
13	Nameplate	G01013(※)	G01013(※)	G01013(※)	G03013(※)	G03013(※)
14	Fixing Screw	G01014	G01014	G01014	G03014	G03014
3-1	Gasket	43650-1	43650-1	43650-1	43650-1	43650-1
3-2	Housing	43650-2	43650-2	43650-2	43650-2	43650-2
3-3	Fixing Screw	43650-3	43650-3	43650-3	43650-3	43650-3
3-4	Grommet	43650-4	43650-4	43650-4	43650-4	43650-4
3-5	Washer	43650-5	43650-5	43650-5	43650-5	43650-5
3-6	Gland Nut	43650-6	43650-6	43650-6	43650-6	43650-6

LEAD-WIRE TYPE 'SWP CONNECTOR'

NO	PART NAME	DSGX-01	DSG-01-AC	DSG-01-DC	DSG-03-AC	DSG-03-DC
3	SWP Connector	ST 730496-3	ST 730496-3	ST 730496-3	ST 730496-3	ST 730496-3
13	Nameplate	G01013(※)	G01013(※)	G01013(※)	G03013(※)	G03013(※)
14	Fixing Screw	G01014	G01014	G01014	G03014	G03014

TERMINAL BOX TYPE

NO	PART NAME	DSGX-01	DSG-01-AC	DSG-01-DC	DSG-03-AC	DSG-03-DC
3	Terminal Box	Ele TB ACT	Ele TB ACT	Ele TB DCT	Ele TB ACT	Ele TB DCT
13	Nameplate	G01013E(※)	G01013E(※)	G01013E(※)	G03013E(※)	G03013E(※)
14	Fixing Screw	G01014P	G01014P	G01014P	G03014P	G03014P
15	O-Ring	P4 x 2 pcs	P4 x 2 pcs	P4 x 2 pcs	P4 x 2 pcs	P4 x 2 pcs
3A	Terminal Box	Ele TB AC	Ele TB AC	Ele TB DC	Ele TB AC	Ele TB DC
3B	Plastic Cover	GPC96	GPC96	GPC96	GPC96	GPC96
3C	Fixing Screw	GPC96S	GPC96S	GPC96S	GPC96S	GPC96S

※: Spool Type: 2B2,2B3,3C2,3C3,3C4.....

★: Coil Voltages:A110,A220.,D12,D24.,RAC110,RAC220.....

◆: Spring: The spool between 3C2-03 & 3C6-03 is different.

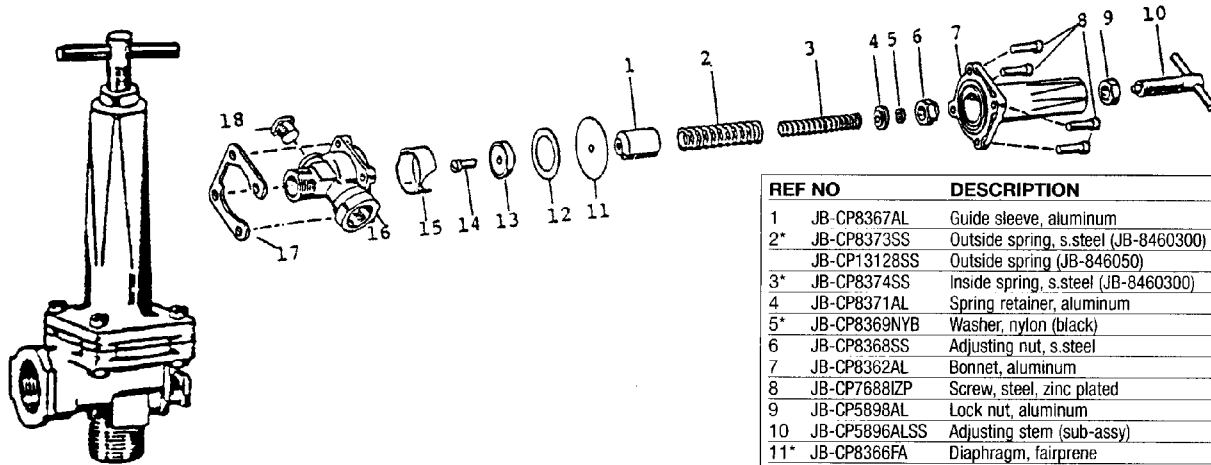

Ce régulateur raccordé au sélecteur 17Y permet d'augmenter ou de réduire la pression du système en tournant la poignée sur le dessus du régulateur. Avec une pompe centrifuge, ce régulateur est remplacé par une valve à billes.

This regulator hooked-up with the 17Y selector allows the operator to increase or decrease the pressure by turning the handle on this regulator. This is replaced by a ball-valve on centrifugal pump.

REF NO	DESCRIPTION	Q
1	JB-CP8367AL Guide sleeve, aluminum	1
2*	JB-CP8373SS Outside spring, s.steel (JB-8460300)	1
	JB-CP13128SS Outside spring (JB-846050)	1
3*	JB-CP8374SS Inside spring, s.steel (JB-8460300)	1
4	JB-CP8371AL Spring retainer, aluminum	1
5*	JB-CP8369NYB Washer, nylon (black)	1
6	JB-CP8368SS Adjusting nut, s.steel	1
7	JB-CP8362AL Bonnet, aluminum	1
8	JB-CP7688IZP Screw, steel, zinc plated	4
9	JB-CP5898AL Lock nut, aluminum	1
10	JB-CP5896ALSS Adjusting stem (sub-assy)	1
11*	JB-CP8366FA Diaphragm, fairprene	1
12	JB-CP8365304SS Stop ring, type 304, s.steel	1
13*	JB-CP8364NYB Back-up seat, nylon (black)	1
14	JB-CP8477SS Screw, s.steel	1
15	JB-CP8389304SS Chamber insert, type 304, s.steel	1
16	JB-CP836112NYB Body, nylon (black) (JB-846012)	1
	JB-CP836134NYB Body, nylon (black) (JB-846034)	1
17	JB-CP9017IZP Clamp plate, steel, zinc plated	1
18	JB-840014PPB Pipe plug, polypropylene (black)	1
	JB-AB8460 Repair kit, incl. all items marked with *	

Vanne régulatrice de pression manuelle • Manual pressure relief valve MP-463080

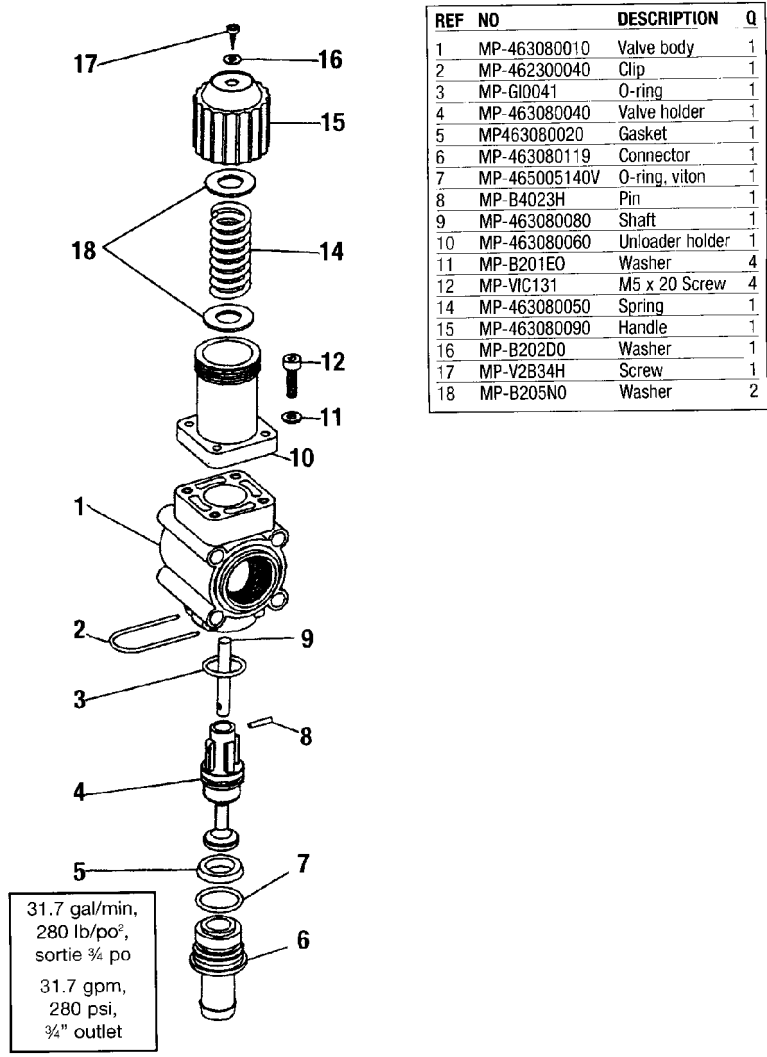

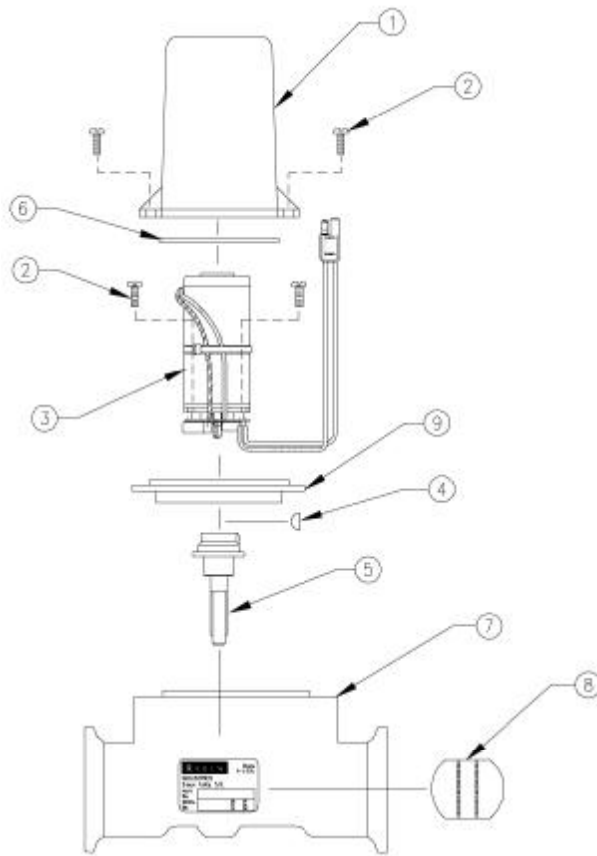

When servicing Valve :

Replace valve body with iso-body kit (item 10) if valve has been leaking internally.

Replace motor assembly if the motor will not run.

Before reassembling valve, remove the coupler shaft from the valve body. Apply Loctite (item 12) to coupler shaft and woodruff key (tem 4) onto the motor shaft. Plug motor into the valve connector coming from Sprayer Control Console. Check that the motor rotates in both directions. Motor must stop when coupler shaft CAM releases printed circuit board button.

When reassembling valve, grease both sealing surfaces of coupler shaft. Insert coupler shaft into iso-flange and be sure seal properly seats on shaft. Install motor on valve body and apply silicon sealant to mounting holes. Reassemble remaining items as shown in parts diagram.

REF N°	DESCRIPTION
1	RA-1060159407 Valve Cover
2	RA-3210000256 #6-32 X3/4' Lg. Screw
3	RA-0630159409 Motor Assembly
4	RA-3210000062 Woodruff Key
5	RA-0630171893 Coupler Shaft Ass. (1 1/2" valve)
6	RA-2190000020 Seal Tetraseal
7	RA-0630171892 Valve Body Ass. (1 1/2" valve)
8	RA-1060159414 Butterfly (1 1/2" valve)
9	RA-0630159457 Isolation Flange Assembly
10	RA-1150159415 *Iso-Body Kit (1 1/2" Valve) (Not shown)
11	RA-1150159415 *Polarity Reversal Jumper (Not shown)
12	RA-2221001050 Loctite RC-609 (Not Finished)
*NOT SUPPLIED WITH STANDARD UNIT	

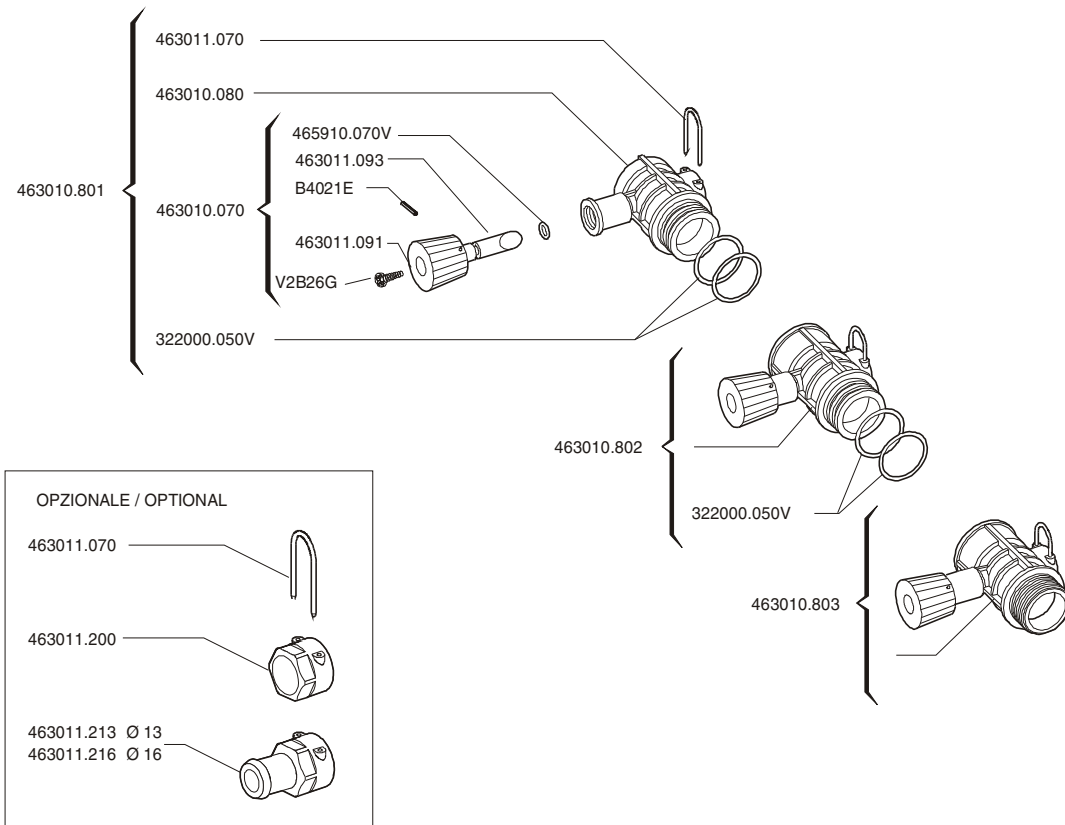

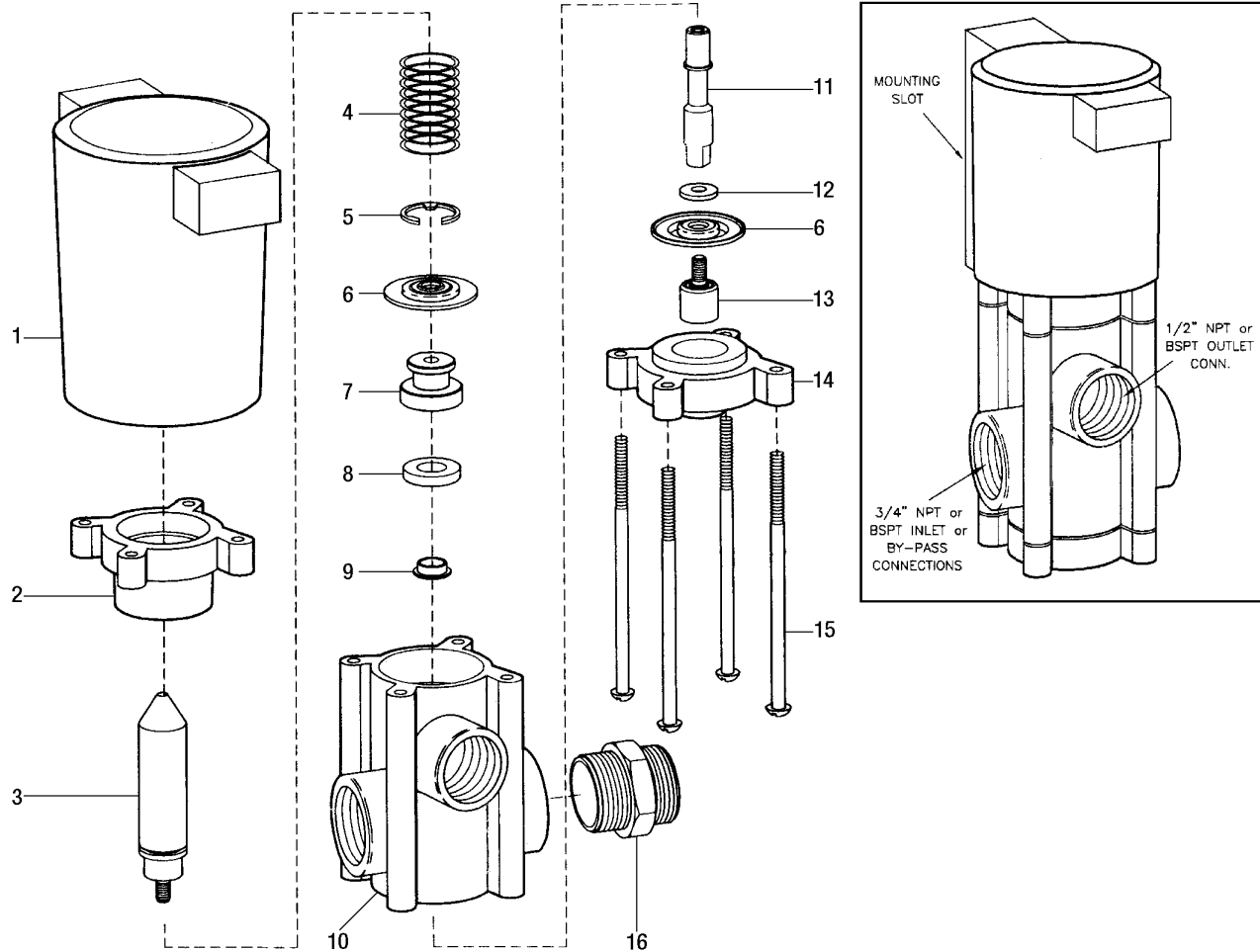

REF NO	DESCRIPTION	Q
1	JB-CP45632 Coil assy, nylon encapsulated (black), aluminum	1
2	JB-CP15164NYB Upper diaphragm housing, nylon, glass filled (black)	1
3	JB-CP45634430FRS Armature, type 430FR s. steel	1
4*	JB-CP45637SS Spring, type 302, s. steel	1
5	JB-CP148132IENP Retaining ring, steel, electroless nickel plated	1
6*	JB-CP36101VI Diaphragm, viton rubber	2
7	JB-14807SS Seat washer retainer, s. steel	1
8*	JB-14802VI Seat washer, viton rubber	1
9	JB-14811SS Spacer, s. steel	1
10	JB-CP14801PP Body, polypropylene (black)	1
11	JB-14812SS Stem, s. steel	1
12	JB-14806SS Washer, s. steel	1
13	JB-CP15162SS Lower diaphragm piston, s. steel	1
14	JB-CP15165NYB Lower diaphragm housing, glass filled nylon (black)	1
15	JB-14819SS Screw, s. steel	4
16	JB-M3400NY40 Connecting nipple, nylon (black)	1
	Use only for multiple units	
JB-AA144P1	One unit DirectoValve, complete	
JB-AA144P2	Two unit DirectoValve, complete	
JB-AA144P3	Three unit DirectoValve, complete	
JB-AB144P1	Spare parts kit (incl. one set of items marked with *)	

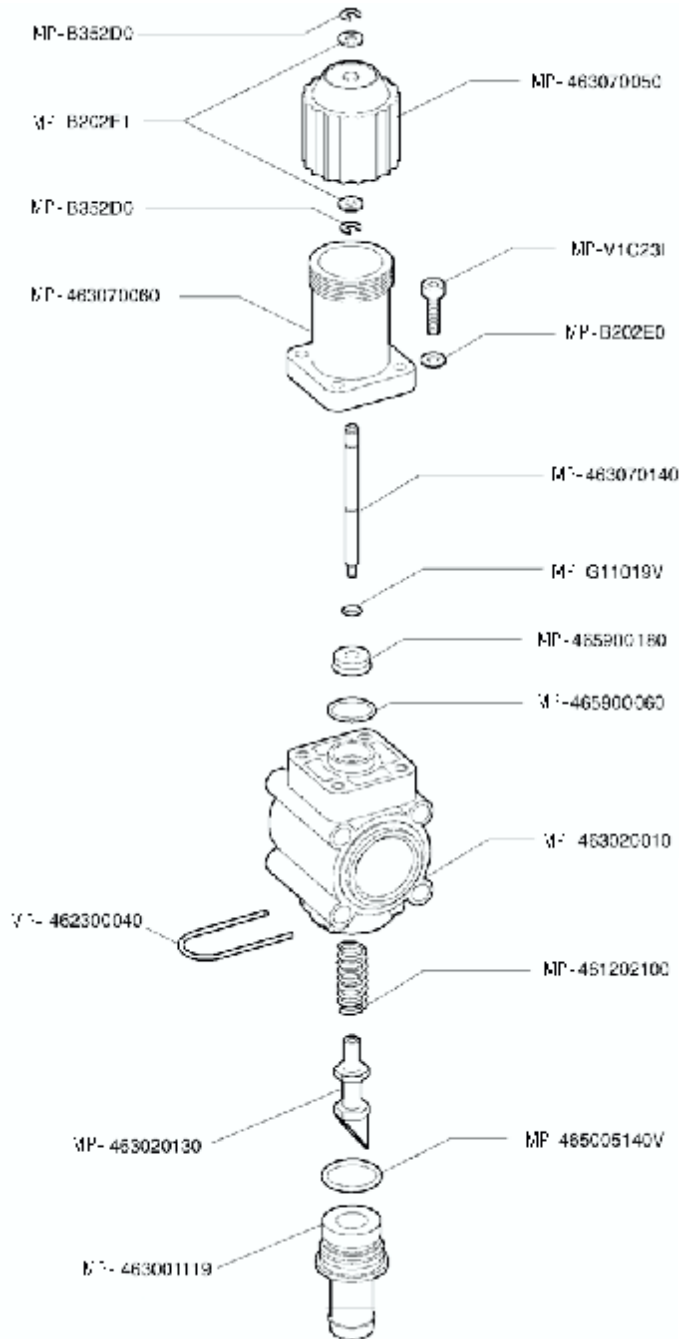

- Adjusts the flow in the control units in which treatments vary in proportion with engine rpm (DPM)
- Fibreglass-reinforced Nylon body
- Internal parts in Delrin® and AISI 303 stainless steel
- Gaskets made of Viton®
- Internal resettable fuse (disconnecting power for 20 seconds)

Manual proportional control valve

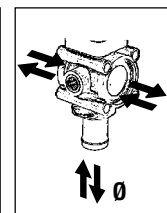
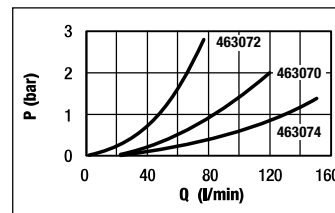

COD.	Pressure		Flow		Ø	
	BAR	PSI	l/1'	US GPM	mm	inches
463072	40	580	60	16	13	1/2"
463070			100	26	19	3/4"
463074			150	40	25	1"

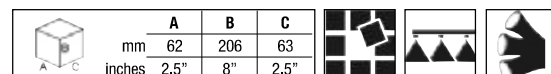

Manually controlled boom section valve

- Fibreglass-reinforced Nylon body
- Internal parts in Delrin® and AISI 303 stainless steel
- Gaskets made of Viton®

COD.	Pressure		Symbol	Ø OUT	
	BAR	PSI		mm	inches
463051	20	290	(♦)	10-13-16	3/8"-1/2"-5/8"
				19-25	3/4"-1"

A C	A	B	C	Icons
	mm	62	214	
inches	2.5"	8.4"	4"	

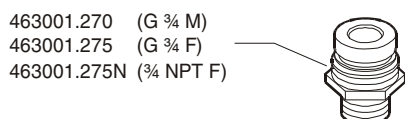
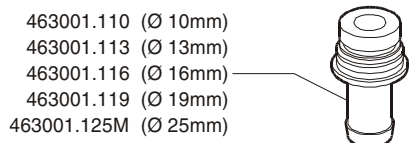
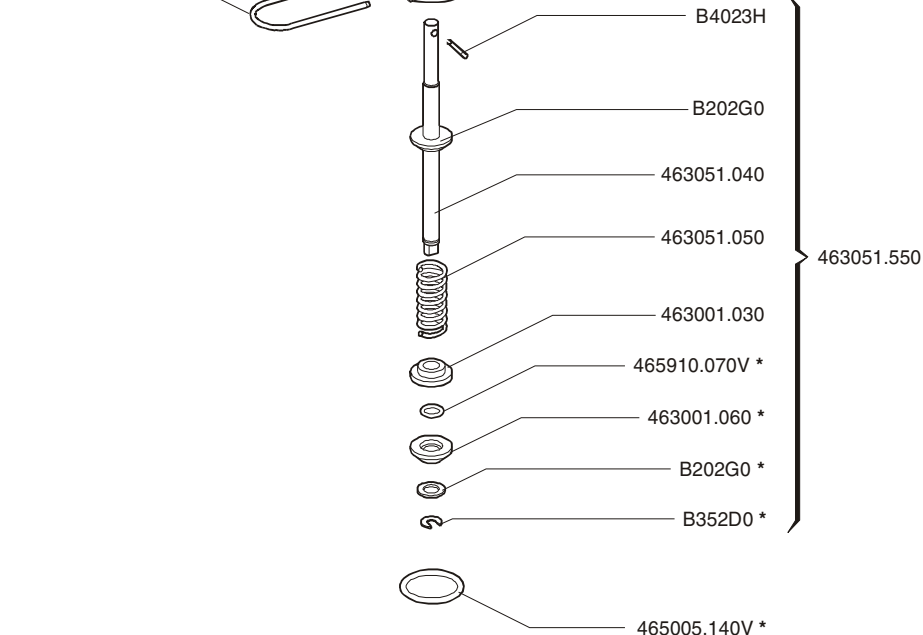
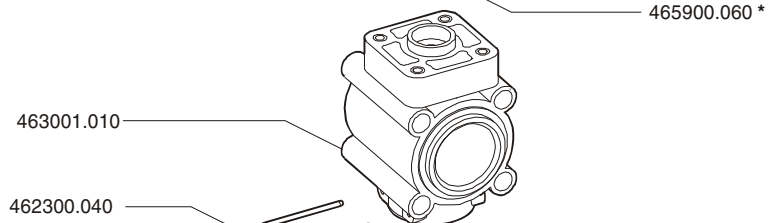
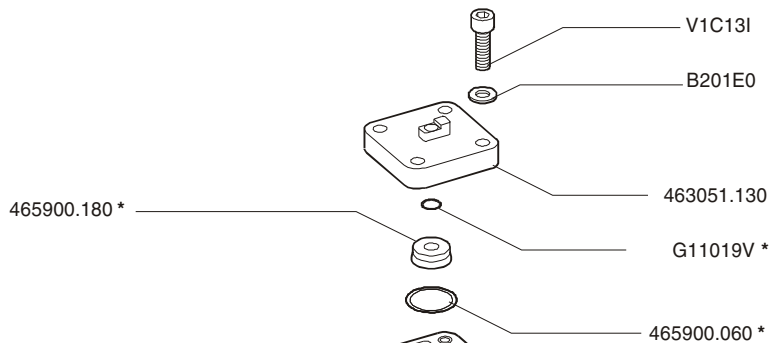
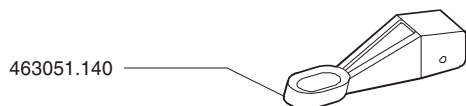

* = 463051.500 Serie guarnizioni
Gasket-set

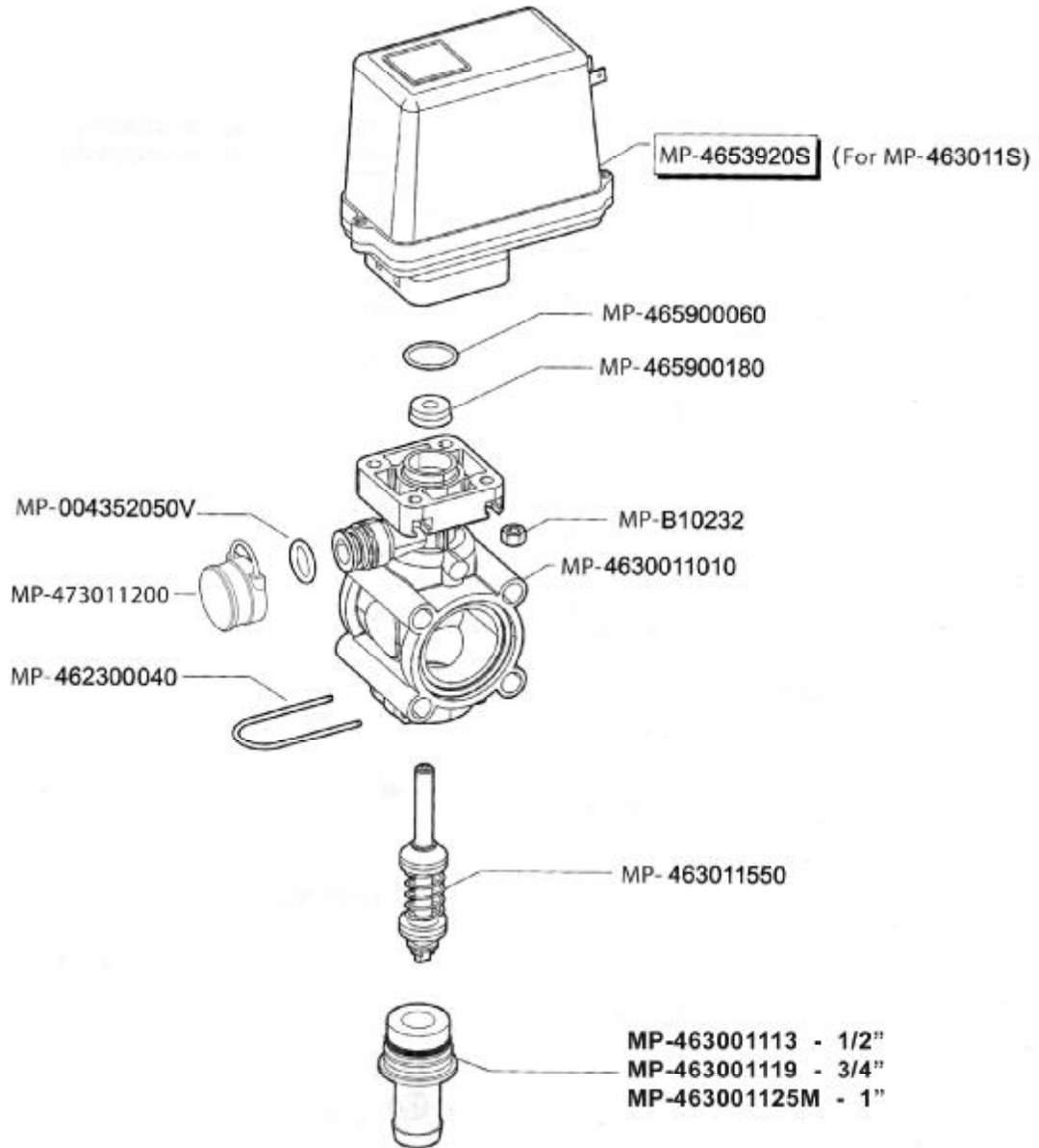

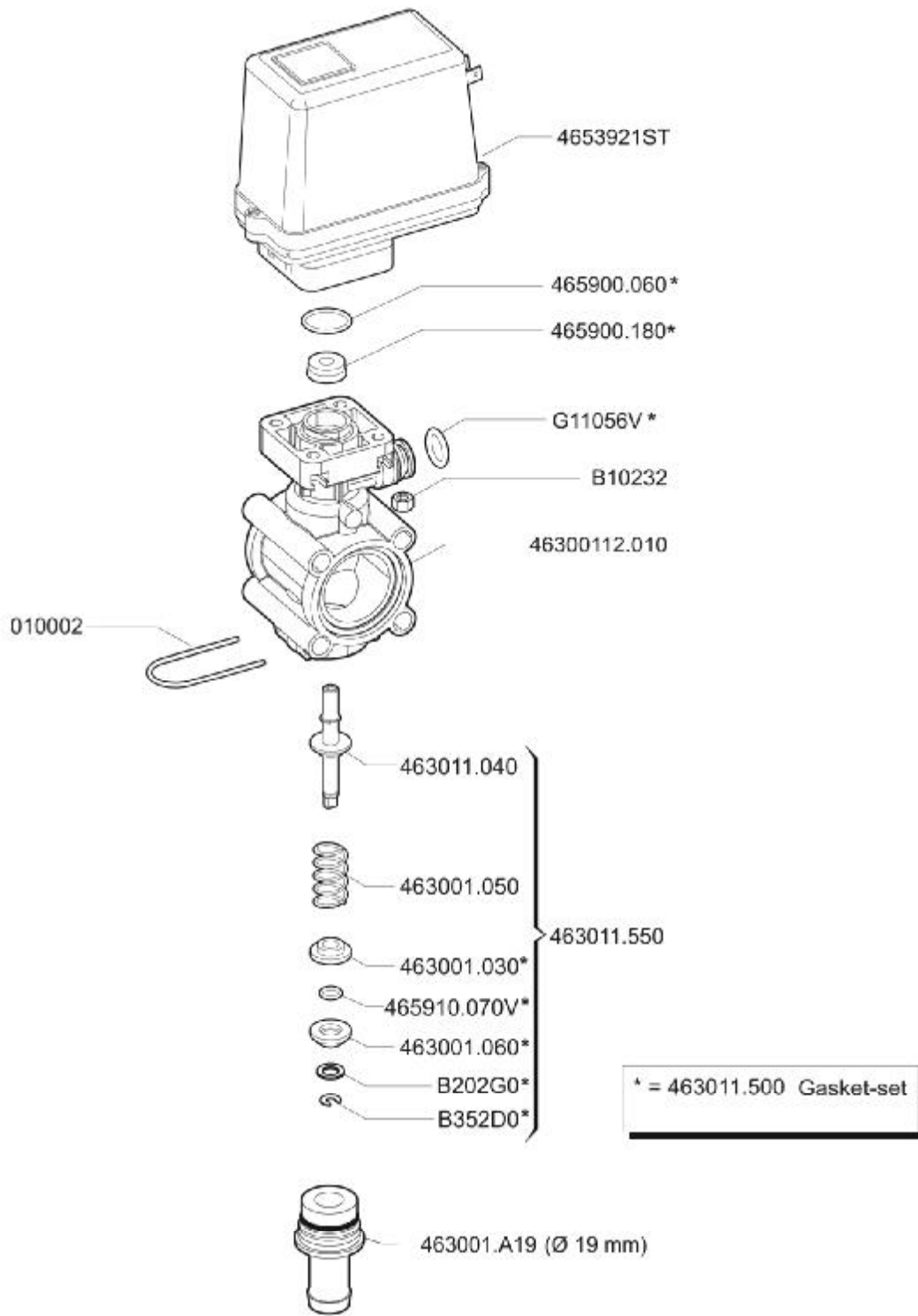

Vanne de réglage proportionnelle • Proportional control valve

MP-473020S

Electric proportional control valve

- Internal resettable fuse (disconnecting power for 20 seconds)

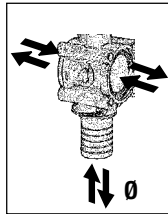
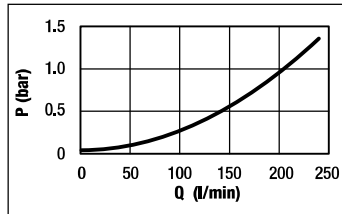

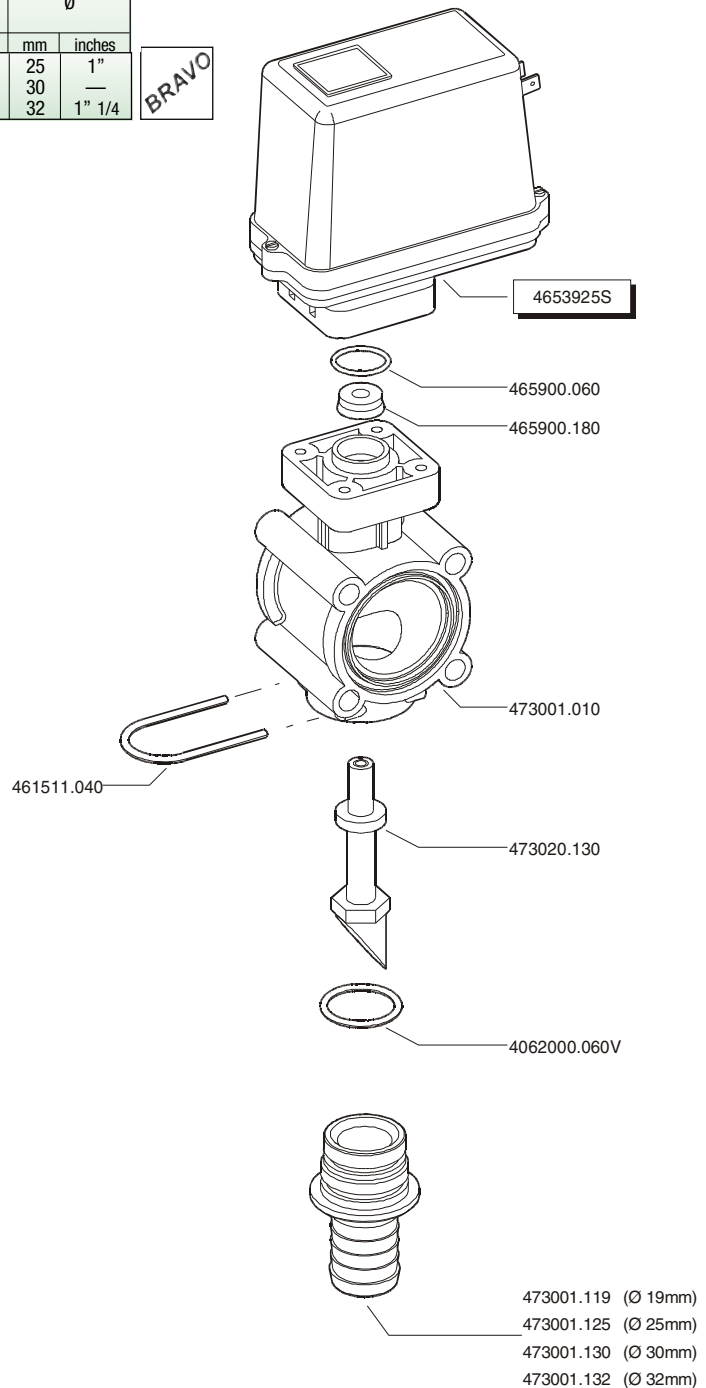

COD.	Pressure		Response time	Voltage	Current	Flow rate		Dimensions	
	BAR	PSI				l/min	US GPM	mm	inches
473020S	20	290	7 sec.	12Vdc 0.5 A	240	63	25 30 32	1" — 1" 1/4	BRAVO

	A	B	C
mm	62	240	111
inches	2.5"	9.5"	4.5"



Manual diaphragm pressure relief control valve with flanged coupling

COD.					Ø BY-PASS (BSP)
	BAR	PSI	lt/1'	US GPM	
▶ 465513	30	460	200	53	G3/4 F
▶ 465514	40	580			
▶ 465521	10	460	200	53	G1 M
▶ 465522	20	580			

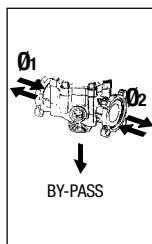

	A	B	C
	mm	120	213
inches	4.5"	8"	3.5"

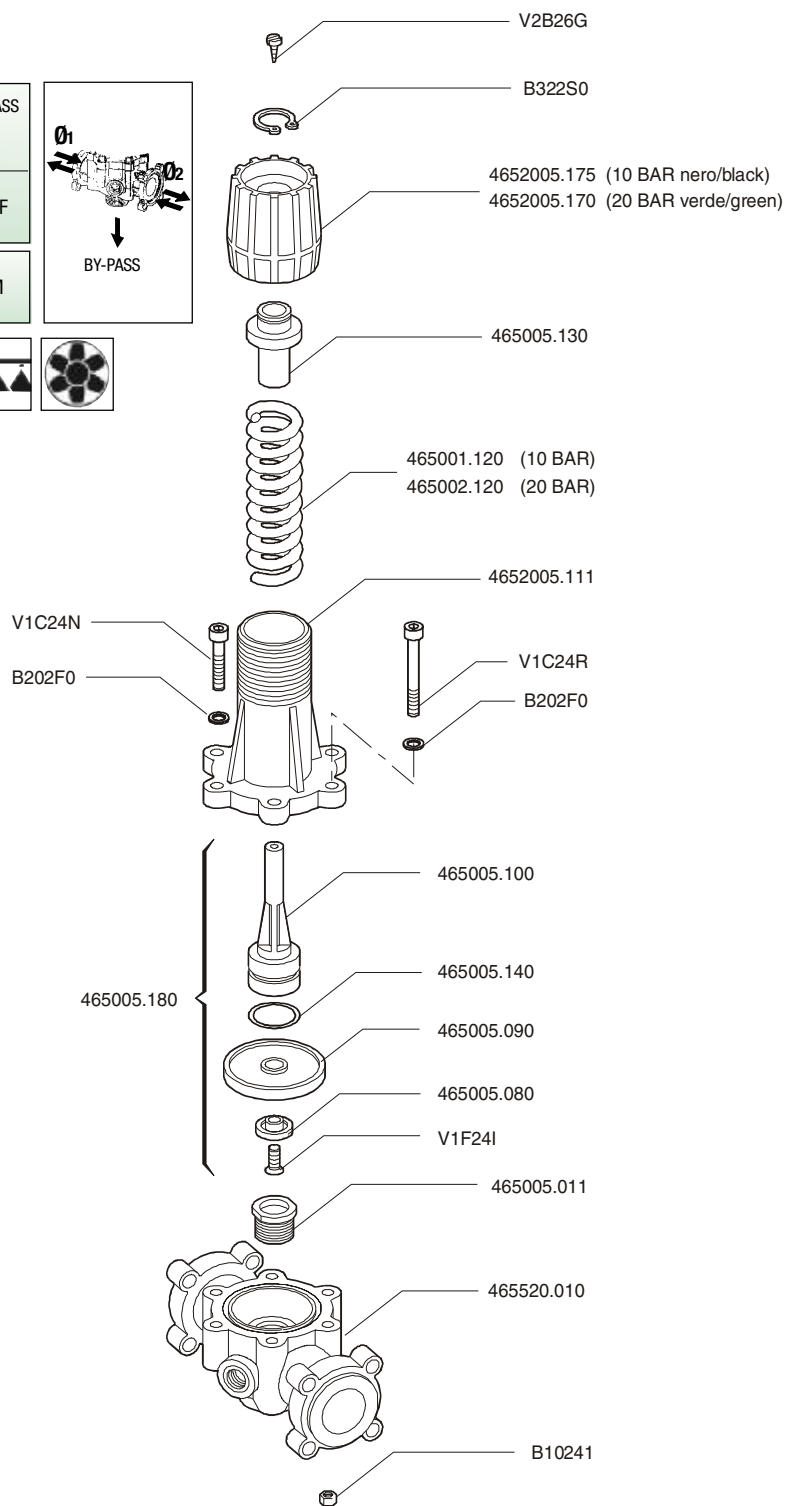

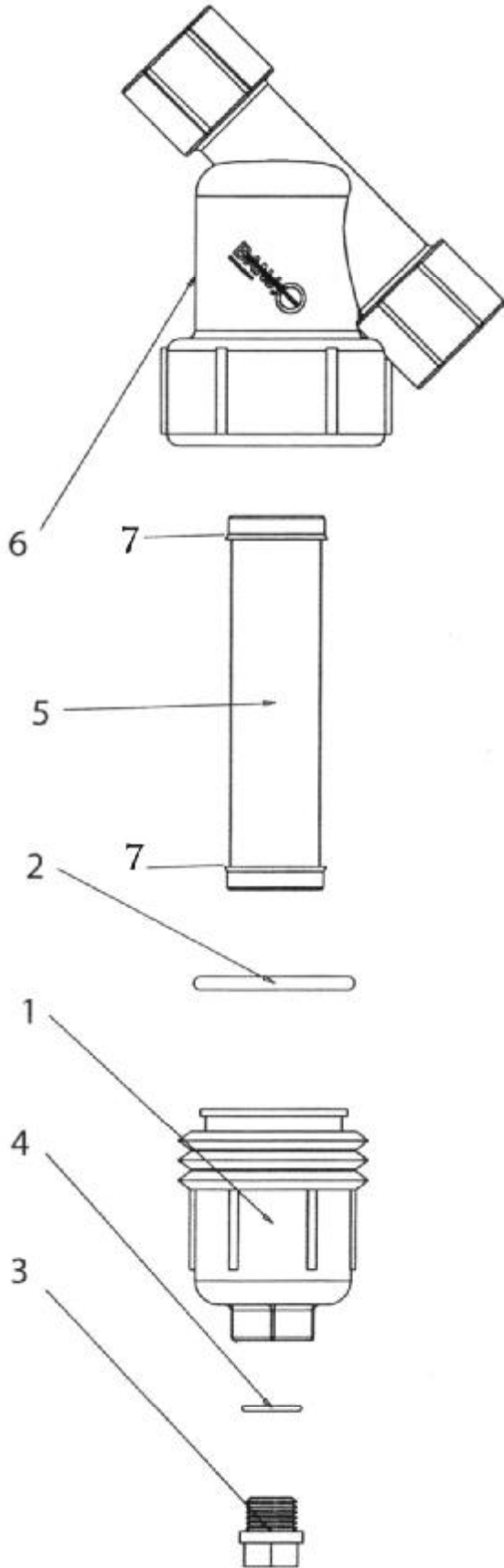

BJ-LS125...

REF	N°	DESCRIPTION	Q
1	BJ-LS100C1	End cap	1
2	BJ-LS100G	Gasket, std	1
	BJ-LS100GV	Gasket-FKM (viton type), opt	1
3	BJ-12777	1/2" drain plug	1
4	BJ-UV15163	EPDM O-ring for drain plug std	1
	BJ-UV15163V	FKM (viton type) O-ring for drain plug, opt	1
5	BJ-LS120	20 mesh screen	1
	BJ-LS140	40 mesh screen	1
	BJ-LS180	80 mesh screen	1
6	N/A	"Y" body 1 1/4"	N/A
7	BJ-LS125G	O-ring	2
KIT	BJ-LS125BC1	"Y" body, cap & gasket, 1 1/4" (includes #1,2,3,4 & 6)	1

BJ-LS150...

REF	N°	DESCRIPTION	Q
1	BJ-LS150C	End cap	1
2	BJ-LS150G	Gasket, std	1
	BJ-LS150GV	Gasket-FKM (viton type), opt	1
3	BJ-LSQ200PL	1" drain plug	1
4	BJ-LSQ200R	EPDM O-ring for drain plug std	1
	BJ-LSQ200RV	FKM (viton type) O-ring for drain plug, opt	1
5	BJ-LS206	6 mesh screen	1
	BJ-LS212	12 mesh screen	1
	BJ-LS220	20 mesh screen	1
	BJ-LS230	30 mesh screen	1
	BJ-LS250	50 mesh screen	1
	BJ-LS280	80 mesh screen	1
	BJ-LS2120	120 mesh screen	1
6	BJ-LS150B	"Y" body 1 1/2"	1
7	BJ-LS141G	O-ring	2
KIT	BJ-LS150BC	"Y" body, cap & gasket, 1 1/2" (includes #1,2,3,4 & 6)	1

BJ-LS200...

REF	N°	DESCRIPTION	Q
1	BJ-LS150C	End cap	1
2	BJ-LS150G	Gasket, std	1
	BJ-LS150GV	Gasket-FKM (viton type), opt	1
3	BJ-LSQ200PL	1" drain plug	1
4	BJ-LSQ200R	EPDM O-ring for drain plug std	1
	BJ-LSQ200RV	FKM (viton type) O-ring for drain plug, opt	1
5	BJ-LS206	6 mesh screen	1
	BJ-LS212	12 mesh screen	1
	BJ-LS220	20 mesh screen	1
	BJ-LS230	30 mesh screen	1
	BJ-LS250	50 mesh screen	1
	BJ-LS280	80 mesh screen	1
	BJ-LS2120	120 mesh screen	1
6	BJ-LS200B	"Y" body 2"	1
7	BJ-LS141G	O-ring	2
KIT	BJ-LS200BC	"Y" body, cap & gasket, 2" (includes #1,2,3,4 & 6)	1

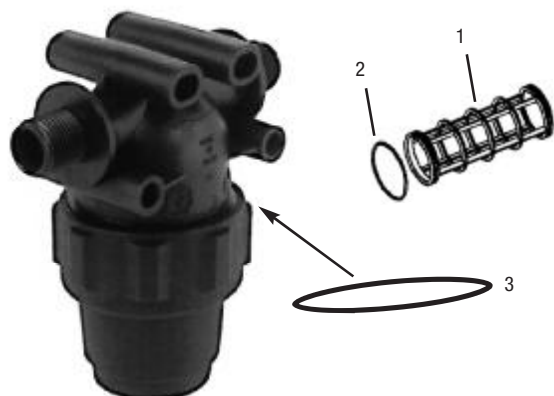

AU-8110009 (1" x 50M), AU-8110011 (1"x100M)

REF N°	DESCRIPTION	Q	
1	MP-323002030	White cartridge, inox 32 mesh	1
	MP-323003030	Blue cartridge, inox 50 mesh	1
	MP-323004030	Red cartridge, inox 100 mesh	1
	MP-323006030	Orange cartridge, inox 150 mesh	1
2	MP-G10051	O'ring	2
3	AU-227	O-ring, buna (standard)	1
	AU-227V	O-ring, viton (optional)	1

Options



Parts List

ITEM	QTY	NAME	DESCRIPTION
1	1	MLST150H	1 1/2 MANIFOLD HEAD
2	1	LST150B	T-STRAINER BOWL
3	1	LST150G	BOWL O'RING
4	1	LST1550	50 MESH SCREEN
5	1	LST100-D	DECAL (N/S)

*NOTE:
ADDITIONAL CLEARANCE REQ'D
FOR SCREEN REMOVAL: 8"

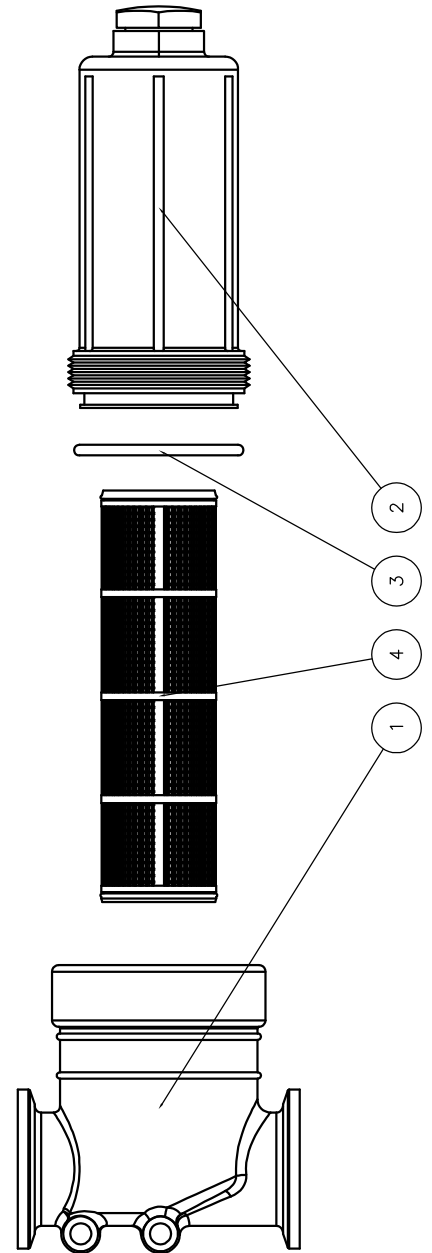
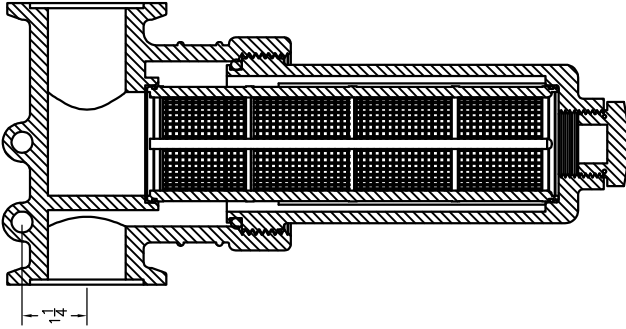
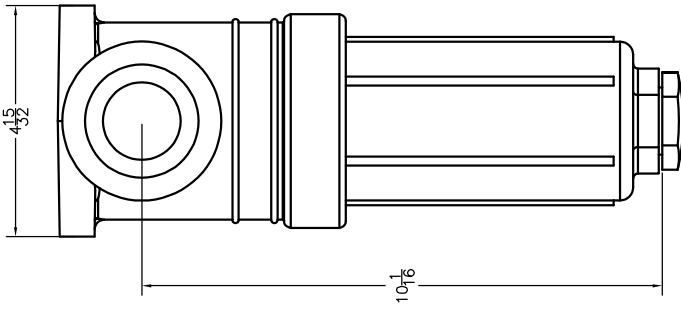
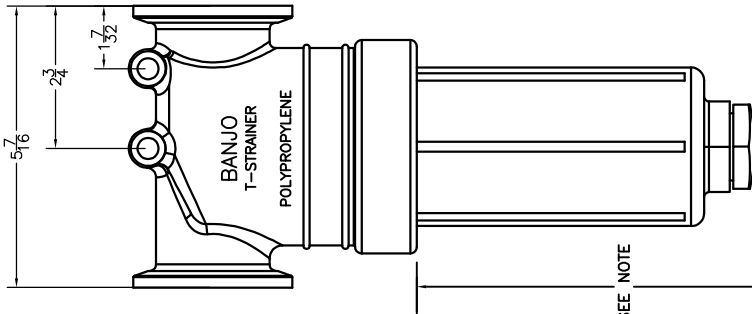
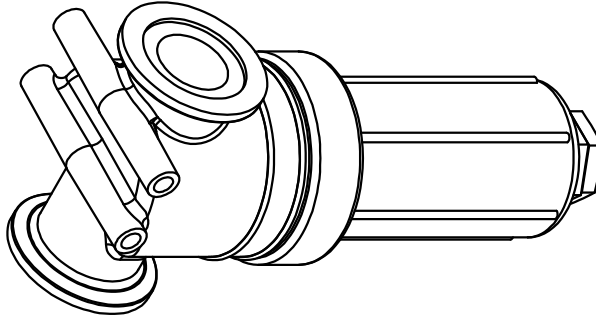

BANJO
LIQUID HANDLING PRODUCTS

BANJO CORPORATION
150 BANJO DR. • CUMBERLAND, IN 47933

PART NO. MLST150-50

TITLE
MANIFOLD T-STRAINER

FOR REMOVAL OF SCREEN, THE
MANIFOLD HEAD MUST BE
DISASSEMBLED TO PROVIDE A MINIMUM
CLEARANCE OF 8" BETWEEN THE
MANIFOLD HEAD AND THE STRAINER
BOWL. THIS CLEARANCE IS REQUIRED
FOR THE SCREEN TO BE REMOVED
AT ANY TIME.

Ajouter le préfixe "JB" avant le # de pièce,
ex : JB-18645
Add the "JB" prefix before the part #,
ex : JB-18645

ITEM	PART NO.	DESCRIPTION
1	CF48223-NYB	Upper Clamp, 1/2", Nylon (Black)
	CF48221-NYB	Upper Clamp, 3/4", Nylon (Black)
	CF48222-NYB	Upper Clamp, 1", Nylon (Black)
	CF48220-NYB	Upper Clamp, 20mm, Nylon (Black)
	CF48224-NYB	Upper Clamp, 25mm, Nylon (Black)
2	CF48256-SS	Pivot Pin, Stainless Steel
	CF48496-NYB	Body, 1/2", Nylon (Black)
3	CF48498-NYB	Body, 3/4", Nylon (Black) (for 3/4" and 25mm versions)
	CF48499-NYB	Body, 1", Nylon (Black)
4	CF48497-NYB	Body, 20mm, Nylon (Black)
	CF7717-2/110-BU	O-Ring, Buna-N
5	CF7717-2/110-VI	O-Ring, Viton (Optional)
	CF48255-1 1/4-302SS	Screw, Stainless Steel
6	CF21953-EPR	Diaphragm, EPDM
	CF21953-VI	Diaphragm, Viton (Optional)
7	21950-10-NYB	End Cap Sub-Ass'y, Nylon (Black)
No. QJ17560A-1/2-NYB(-VI) - Hinged Nozzle Body Assembly		
No. QJ17560A-3/4-NYB(-VI) - Hinged Nozzle Body Assembly		
No. QJ17560A-1-NYB(-VI) - Hinged Nozzle Body Assembly		
No. QJ17560A-20mm-NYB(-VI) - Hinged Nozzle Body Assembly		
No. QJ17560A-25mm-NYB(-VI) - Hinged Nozzle Body Assembly		
Note: -VI in part number specifies Viton material for parts #4 and 6		

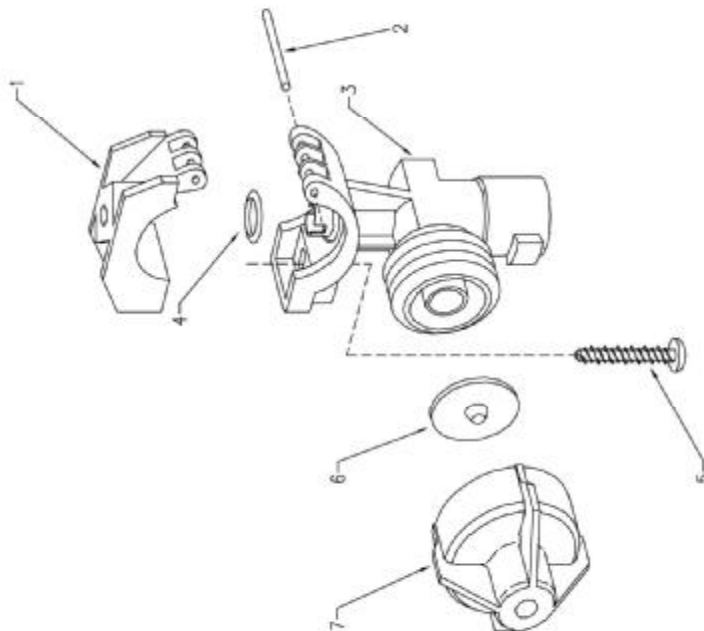

DESCRIPTION:
QJ17560A HINGED CLAMP
WET BOOM DIAPHRAGM
CHECK VALVE QUICK TEE-JET
NOZZLE BODY ASSEMBLY
1 1/2", 3/4", 1", 20mm, & 25mm



Spraying Systems Co.
Spray Nozzles and Accessories
P.O. Box 7900 • Wheaton, IL 60189-7900

Parts List No.
PL QJ17560A
SHEET OF

Rev. No.
Ref.

ITEM	PART NO.	DESCRIPTION
	58445	EC MOTOR, 22-RPM (0.7-SEC), DIN CONNECTION, POSITIVELY SWITCHED
1	58446	E MOTOR, 22-RPM (0.7-SEC), DIN CONNECTION, POSITIVELY SWITCHED
	58447	EC MOTOR, 22-RPM (0.7-SEC), DIN CONNECTION, NEGATIVELY SWITCHED
2	CF58436-302SS	FLAT WASHER, 302 STAINLESS STEEL
3	CF7717-14.8X1.8-VI	O-RING, VITON
4	CF58435-SS	STEM, 303 STAINLESS STEEL
5	CF58469-SS	E-CLIP RETAINING RING, 17PH STAINLESS STEEL
6	CF58450-302SS	MOTOR RETAINING CLIP, 302 STAINLESS STEEL
7	CF58431-PP	VALVE BODY, POLYPROPYLENE (BLACK)
8	CF50507-304SS	MOUNTING PLATE, 304 STAINLESS STEEL
9	CF7717-2-115-VI	O-RING, VITON (2 REQ'D)
10	CF58434-TEF	SEAL, TEFLON (2 REQ'D)
11	CF58433-SS	2-WAY BALL 303 STAINLESS STEEL
12	CF58465-302SS	SCREW, 302 STAINLESS STEEL (2 REQ'D)
13	CF7717-2-120-VI	O-RING, VITON
14	CF58432-PP	END CAP, POLYPROPYLENE (BLACK)
	CF58468-1-SS	ONE BANK MANIFOLD CONNECTING ROD, 303 STAINLESS STEEL
	CF58468-2-SS	TWO BANK MANIFOLD CONNECTING ROD, 303 STAINLESS STEEL
	CF58468-3-SS	THREE BANK MANIFOLD CONNECTING ROD, 303 STAINLESS STEEL
	CF58468-4-SS	FOUR BANK MANIFOLD CONNECTING ROD, 303 STAINLESS STEEL
15	CF58468-5-SS	FIVE BANK MANIFOLD CONNECTING ROD, 303 STAINLESS STEEL
	CF58468-6-SS	SIX BANK MANIFOLD CONNECTING ROD, 303 STAINLESS STEEL
	CF58468-7-SS	SEVEN BANK MANIFOLD CONNECTING ROD, 303 STAINLESS STEEL
	CF58468-8-SS	EIGHT BANK MANIFOLD CONNECTING ROD, 303 STAINLESS STEEL
	CF58468-9-SS	NINE BANK MANIFOLD CONNECTING ROD, 303 STAINLESS STEEL
16	CF58555-SS	M8 SPLIT LOCK WASHER (2 REQ'D)
17	CF46074-302SS	M8X1.25 HEX NUT, 302 STAINLESS STEEL (2 REQ'D)
18	CF58437-PP	MALE INLET ADAPTER, POLYPROPYLENE (BLACK)
19	CF58438-PP	FEMALE INLET ADAPTER, POLYPROPYLENE (BLACK)
20	CF7717-2-225-VI	O-RING, VITON (2 REQ'D)
58470		VALVE BODY SUB-ASSY, INCLUDES ITEMS 2-5, 7-14
	AB430-KIT	SPARE PARTS KIT (INCLUDES ITEMS 3,9,10)
	58561	430 TWO WAY BALL & STEM KIT (INCLUDES ITEMS 2,3,4,5,11)
	58563	INLET ADAPTER KIT (INCLUDES ITEMS 18,19,20)
	58564-3	THREE VALVE MANIFOLD ASSEMBLY KIT (INCLUDES ITEMS 15-20)
	58564-5	FIVE VALVE MANIFOLD ASSEMBLY KIT (INCLUDES ITEMS 15-20)
	58564-7	SEVEN VALVE MANIFOLD ASSEMBLY KIT (INCLUDES ITEMS 15-20)
	58564-9	NINE VALVE MANIFOLD ASSEMBLY KIT (INCLUDES ITEMS 15-20)

NOTE: ALL MANIFOLD ASSEMBLY KITS (58564-*) INCLUDE THE CORRECT ROD (ITEM 15) AND TWO PIECES OF ITEMS 16, 17, & 20.

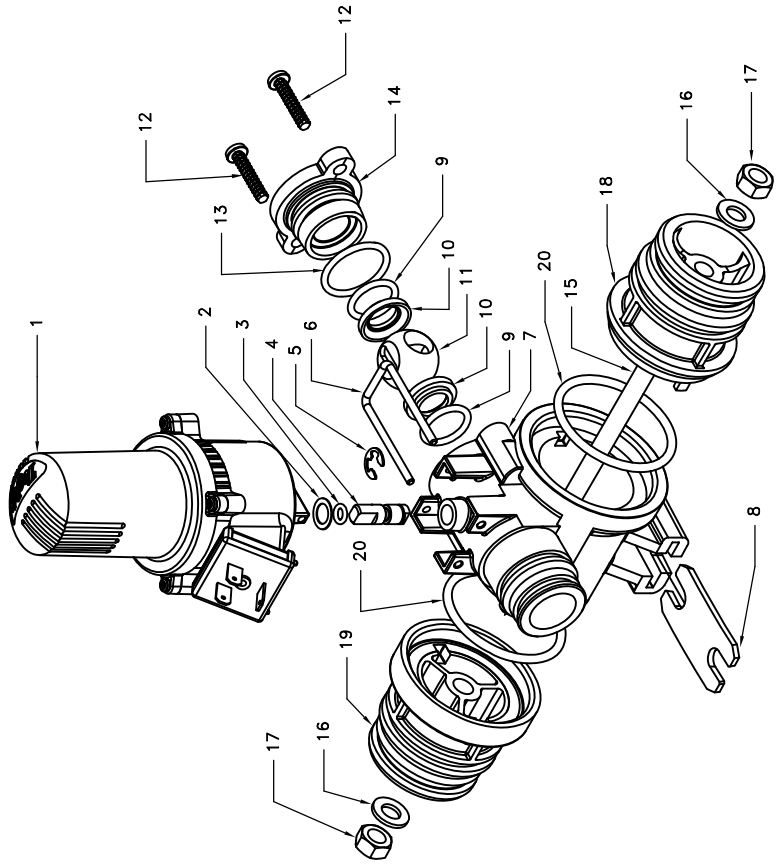

ASSEMBLY NOTE: WHEN ASSEMBLING MANIFOLD, CENTER THE CONNECTING ROD (ITEM 15) BEFORE TIGHTENING HEX NUTS (ITEM 17).

DESCRIPTION:
430EC AND 430E
DIRECTVALVE®
ELECTRIC SHUT-OFF
BALL VALVE MANIFOLD



Spraying Systems Co.
 Spray Nozzles and Accessories
 P.O. Box 7900 - Wheaton, IL 60189-7900

Rev. No. 2
 Ref.

PARTS LIST
PL430EC-2
 SHEET OF

REF N°	DESCRIPTION	Q
1	JB-CP48255114430SS Screw, 430 s. steel	1
2	JB-CP48221NYB 3/4" upper clamp, nylon, black	1
3	JB-CP77172110BU* O-ring, buna-n	1
	JB-CP77172110VI** O-ring, viton (opt.)	1
4	JB-CP38925NYB 20mm split eyelet body, nylon, black	1
5	JB-CP21953EPR* Diaphragm, EPDM rubber	1
	JB-CP21953VI** Diaphragm, viton (opt.)	1
6	JB-2195010NYB ChamSaver end cap assy, nylon, black	1
7	JB-CP389431VI** Seal, viton (B series)	1
7A	JB-CP56726VITFE Seal, viton-Teflon filled (C series)	1
7B	JB-CP77172111V O-ring, viton (C series)	1
8A	JB-CP38921NYB #363 Turret, nylon, black	1
8B	JB-CP38922NYB #364 Turret, nylon, black	1
8C	JB-CP38923NYB #365 Turret, nylon, black	1
9	JB-CP38931NYB E-clip, nylon, black	1
10	JB-CP77172113EPR* O-ring, EPDM rubber (std)	1
	JB-CP77172113VI** O-ring, viton (opt.)	1
11	JB-CP77172216EPR* O-ring, EPDM rubber (std)	1
	JB-CP77172216VI** O-ring, viton (opt.)	1
12	JB-CP38930NYB Plug, nylon, black	1
13	JB-CP38936NYB 1/2" single hose shank, nylon, black	1
	JB-CP38938NYB 3/4" single hose shank, nylon, black	1
	JB-CP38940NYB 1" single hose shank, nylon, black	1
14	JB-CP38937NYB 1/2" double hose shank, nylon, black	1
	JB-CP38939NYB 3/4" double hose shank, nylon, black	1
	JB-CP38941NYB 1" double hose shank, nylon, black	1
15	JB-CP38948NYB 1/2" NPTx3/4" hose shank, nylon, black	1
16	JB-CP48256SS Pivot pin, 303 s. steel	1
17	JB-CP77172129EPR* O-ring dust seal, EPR rubber (std)	1
	JB-CP77172129VI** O-ring dust seal, viton rubber (opt.)	1

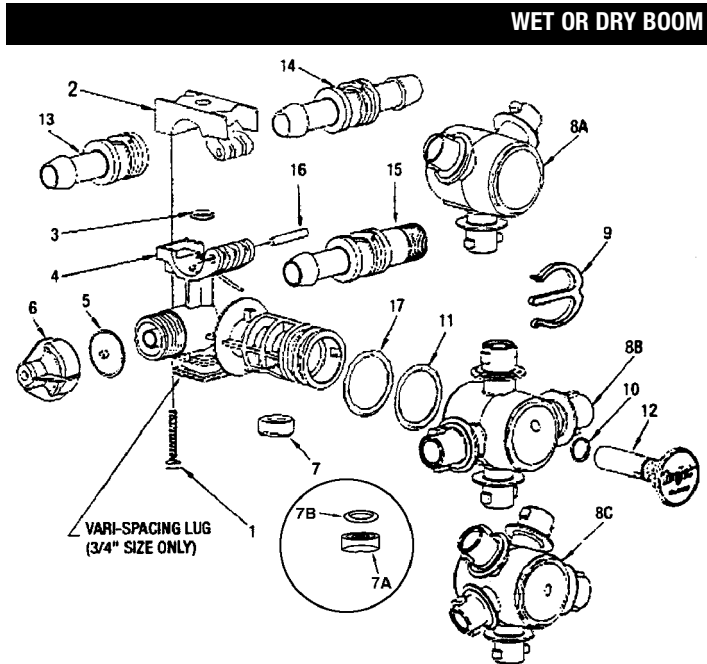

Ensemble de supports de buses multiples / Multiple nozzle bodies & assemblies

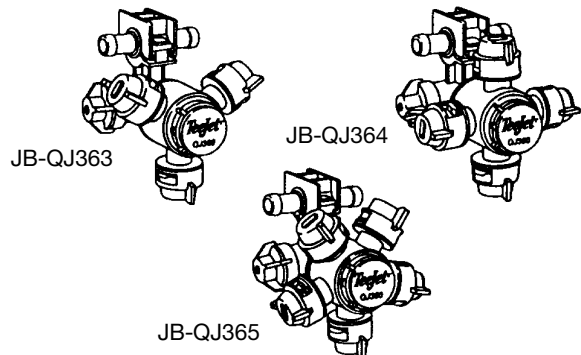

360 Nozzle Body Series for Wet or Dry Booms

- Disponible avec 3, 4 ou 5 positions de pulvérisation pour changement rapide de buse ou vidange de la rampe.
- Fermeture complète entre chaque position de pulvérisation.
- Pression maximale d'opération de 300 lb/po².
- Disponible avec des corps de buse (boyau) de 20mm, 1/2, 3/4 ou 1 po.
- Valve anti-retour ChemSaver® incluse pour fermeture sans gouttage.
- Membrane EPDM standard et membrane en viton disponible en option.
- Available with either 3, 4 or 5 spray positions for easy change of spray tips or quick boom flushing.
- Positive shut-off between each spray position.
- Maximum operating pressure of 300 psi.
- Available in 1/2", 3/4" or 1" single or double hose shanks.
- Includes ChemSaver® diaphragm check valve for drip-free shutoff.
- Standard EPDM diaphragm with Viton available as an option.

WET BOOM

PART N°	NUMBER OF SPRAY OUTLETS	TO CLAMP ON
JB-QJ36312NYB	3	1/2" Pipe
JB-QJ36334NYB	3	3/4" Pipe
JB-QJ3631NYB	3	1" Pipe
JB-QJ36412NYB	4	1/2" Pipe
JB-QJ36434NYB	4	3/4" Pipe
JB-QJ3631NYB	4	1" Pipe
JB-QJ3652012NYB	5	1/2" Pipe
JB-QJ36534NYB	5	3/4" Pipe
JB-QJ3651NYB	5	1" Pipe

DRY BOOM

PART N°	Single	Double	To Fit	
			Spray Outlets	Hose I.D.
JB-QJ3635001NYB		JB-QJ3635002NYB	3	1/2"
JB-QJ3637501NYB		JB-QJ3637502NYB	3	3/4"
JB-QJ36310001NYB		JB-QJ36310002NYB	3	1"
JB-QJ3645001NYB		JB-QJ3645002NYB	4	1/2"
JB-QJ3647501NYB		JB-QJ3647502NYB	4	3/4"
JB-QJ36410001NYB		JB-QJ36410002NYB	4	1"
JB-QJ3655001NYB		JB-QJ3655002NYB	5	1/2"
JB-QJ3657501NYB		JB-QJ3657502NYB	5	3/4"
JB-QJ36510001NYB		JB-QJ36510002NYB	5	1/2"

JB-5500

Le corps de la buse cannelé tourne d'un demi-tour pour permettre le passage de l'atomisation avec jet conique grand angle à un jet rectiligne. Les positions "A" et "B" de la buse sont les deux points extrêmes de rotation pour le réglage de la buse. D'autres tailles sont également disponibles.

Knurled body of tip rotates through a half turn to provide spray selection from wide angle, finely atomized cone spray to a straight stream spray. Tip settings "A" and "B" represent two extreme points of rotation in tip adjustment. Other sizes available.

For Capacities from 0.017 to 1.9 GPM

JB-5500-PP

La buse orientable ConeJet JB-5500 est disponible également en polypropylène. La buse en polypropylène a les mêmes caractéristiques que la buse en laiton et est très résistante aux produits chimiques. Son faible poids convient pour l'emploi sur des pulvérisateurs manuels à dos.

The JB-5500 Adjustable ConeJet tip is also available in a polypropylene version. The polypropylene tip has the same performance characteristics as the brass tip and provides excellent chemical resistance. This tip's light weight makes it well-suited for use on hand held and backpack type sprayers.

ADJUSTABLE CONEJET TIP No.	PERFORMANCE	LIQUID PRESSURE IN PSI											
		20 psi Setting		30 psi Setting		40 psi Setting		60 psi Setting		100 psi Setting		150 psi Setting	
		A	B	A	B	A	B	A	B	A	B	A	B
JB-5500X1	Capacity-GPM	—	.049	.015	.061	.017	.07	.02	.086	.025	.11	.028	.14
	Spray angle	—	—	38°	—	54°	—	71°	—	80°	—	83°	—
	Max. Throw-Ft.	—	19	1	22	1.5	24	1.5	26	1.5	26	1.5	26
JB-5500X2	Capacity-GPM	.025	.091	.03	.11	.033	.13	.04	.16	.05	.20	.058	.25
	Spray angle	40°	—	60°	—	68°	—	75°	—	80°	—	83°	—
	Max. Throw-Ft.	1.5	23	1.5	26	2	27	2	28	2	28	2	28
JB-5500X3 JB-5500PPBX3	Capacity-GPM	.037	.13	.045	.17	.05	.19	.058	.23	.073	.30	.088	.37
	Spray angle	57°	—	68°	—	72°	—	76°	—	80°	—	82°	—
	Max. Throw-Ft.	2	27	2	30	2	31	2	31	3	31	3	31
JB-5500X4	Capacity-GPM	.05	.18	.058	.22	.067	.25	.08	.31	.10	.40	.12	.49
	Spray angle	61°	—	70°	—	73°	—	77°	—	80°	—	81°	—
	Max. Throw-Ft.	2.5	30	2.5	33	3	34	3	34	3	34	3	34
JB-5500X5 JB-5500PPBX5	Capacity-GPM	.061	.21	.076	.26	.082	.30	.10	.37	.13	.48	.15	.58
	Spray angle	61°	—	70°	—	74°	—	77°	—	80°	—	81°	—
	Max. Throw-Ft.	2.5	31	2.5	34	3	35	3	35	3	35	3	35
JB-5500X6 JB-5500PPBX6	Capacity-GPM	.073	.26	.087	.32	.10	.37	.12	.45	.15	.58	.19	.71
	Spray angle	65°	—	71°	—	74°	—	77°	—	80°	—	80°	—
	Max. Throw-Ft.	2.5	32	3	35	3	36	3.5	36	3.5	36	3.4	36
JB-5500X8 JB-5500PPBX8	Capacity-GPM	.097	.33	.12	.40	.13	.47	.16	.57	.21	.74	.25	.90
	Spray angle	66°	—	71°	—	74°	—	77°	—	80°	—	80°	—
	Max. Throw-Ft.	3	34	3	37	3	38	3	38	4	38	4	38
JB-5500X10	Capacity-GPM	.12	.42	.15	.52	.17	.60	.21	.73	.26	.94	.31	1.2
	Spray angle	68°	—	72°	—	75°	—	78°	—	80°	—	80°	—
	Max. Throw-Ft.	3	35	3.5	38	3.5	39	4	40	4	40	4	40
JB-5500X12 JB-5500PPBX12	Capacity-GPM	.15	.49	.18	.60	.20	.69	.24	.84	.31	1.1	.38	1.3
	Spray angle	69°	—	73°	—	76°	—	78°	—	80°	—	80°	—
	Max. Throw-Ft.	3.5	36	4	39	4	40	4	41	4	41	4	41
JB-5500X14	Capacity-GPM	.17	.55	.20	.67	.23	.78	.29	.95	.37	1.2	.45	1.5
	Spray angle	70°	—	74°	—	76°	—	78°	—	80°	—	80°	—
	Max. Throw-Ft.	3.5	37	4	40	4	41	4	41	4.5	41	4.5	41
JB-5500X18 JB-5500PPBX18	Capacity-GPM	.21	.69	.26	.84	.30	.97	.37	1.2	.47	1.5	.58	1.9
	Spray angle	71°	—	75°	—	77°	—	78°	—	80°	—	79°	—
	Max. Throw-Ft.	4	38	4	41	4	42	4	42	5	42	5	42
JB-5500X22	Capacity-GPM	.26	.83	.32	1.0	.37	1.2	.45	1.4	.58	1.9	.70	2.3
	Spray angle	71°	—	75°	—	78°	—	79°	—	80°	—	78°	—
	Max. Throw-Ft.	4	39	4.5	41	5	42	5	42	5	42	5	42
JB-5500X26	Capacity-GPM	.31	.98	.37	1.2	.43	1.4	.53	1.7	.68	2.2	.83	2.7
	Spray angle	72°	—	76°	—	78°	—	79°	—	80°	—	78°	—
	Max. Throw-Ft.	4.5	40	5	42	5	43	5.5	43	5.5	43	5.5	43

Above data is based on spraying water from a height of about 2-1/2 feet with tip tilted about as shown at left for each setting

TIP SETTING "A"
CONE SPRAY PATTERN



TIP SETTING "B"
STRAIGHT STREAM SPRAY PATTERN

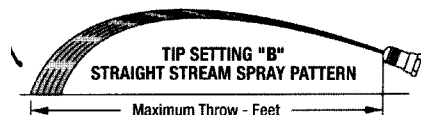

TeeJet® Off-Center Flat Spray Tips — Smaller Capacities

TeeJet Off-Center spray tips are commonly installed in double and single swivel nozzle bodies. Because these bodies are adjustable for angular position, a wide spray swath is easily obtained.

See page 59 for swivels and hose drops.

How to order:
Specify tip number and material.
Example: OC-02 Brass



Tip	Capacity One Nozzle IN l/min	HEIGHT = 45 cm							HEIGHT = 60 cm			
		W* cm	l/ha				W* cm	l/ha				
			4 km/h	6 km/h	8 km/h	10 km/h		4 km/h	6 km/h	8 km/h	10 km/h	
OC-01 (100)	2.0	147	32.7	21.8	16.3	11.1	165	29.1	19.4	14.5	11.6	
	3.0	152	38.5	25.7	19.2	15.4	170	34.4	22.9	17.2	13.8	
	4.0	157	43.0	28.7	21.5	17.2	175	38.6	25.7	19.3	15.4	
OC-02 (50)	2.0	172	56.7	37.8	28.3	22.7	190	51.3	34.2	25.7	20.5	
	3.0	177	66.9	44.6	33.5	26.8	195	60.8	40.5	30.4	24.3	
	4.0	182	75.0	50.0	37.5	30.0	198	68.9	46.0	34.5	27.6	
OC-03 (50)	2.0	195	73.8	49.2	36.9	29.5	203	70.9	47.3	35.5	28.4	
	3.0	198	87.2	58.1	43.6	34.9	210	84.3	56.2	42.1	33.7	
	4.0	208	98.1	65.4	49.0	39.2	215	94.9	63.3	47.4	38.0	
OC-04 (50)	2.0	231	83.8	55.8	41.9	33.5	236	82.0	54.7	41.0	32.8	
	3.0	236	100	66.9	50.2	40.2	238	99.6	66.4	49.8	39.8	
	4.0	238	115	76.5	57.4	45.9	241	113	75.5	56.6	45.3	
OC-06 (50)	2.0	251	116	77.3	58.0	46.4	274	106	70.8	53.1	42.5	
	3.0	256	139	92.6	69.4	55.5	279	127	84.9	63.7	51.0	
	4.0	259	159	106	79.3	63.5	281	146	97.5	73.1	58.5	
OC-08 (50)	2.0	254	152	102	76.2	60.9	279	139	92.5	69.4	55.5	
	3.0	259	183	122	91.5	73.2	284	167	111	83.5	66.8	
	4.0	264	207	136	104	83.0	287	191	127	95.4	76.3	
OC-12	2.0	259	224	149	112	89.7	287	202	135	101	80.9	
	3.0	264	269	180	135	108	292	243	162	122	97.4	
	4.0	266	308	206	154	123	294	279	186	140	112	
OC-16	2.0	335	231	154	116	92.4	360	215	143	108	86.0	
	3.0	350	271	181	135	108	370	256	171	128	102	
	4.0	363	302	201	151	121	375	292	195	146	117	

Note: Always double check your application rates. See pages 149-163 for useful formulas and information.

Tip	Capacity One Nozzle IN GPM	HEIGHT = 18'							HEIGHT = 24'			
		W* IN INCHES	GPA				W* IN INCHES	GPA				
			3 MPH	4 MPH	5 MPH	6 MPH		3 MPH	4 MPH	5 MPH	6 MPH	
OC-01 (100)	30	58	3.0	2.2	1.8	1.5	65	2.7	2.0	1.6	1.3	
	40	60	3.3	2.5	2.0	1.7	67	3.0	2.2	1.8	1.5	
	60	62	3.8	2.9	2.3	1.9	69	3.4	2.6	2.1	1.7	
OC-02 (50)	30	68	5.0	3.7	3.0	2.5	75	4.5	3.4	2.7	2.2	
	40	70	5.7	4.2	3.4	2.8	77	5.1	3.9	3.1	2.6	
	60	72	6.6	5.0	4.0	3.3	78	6.1	4.6	3.7	3.0	
OC-03 (50)	30	77	6.7	5.0	4.0	3.3	80	6.4	4.8	3.9	3.2	
	40	80	7.4	5.6	4.5	3.7	83	7.2	5.4	4.3	3.6	
	60	82	8.9	6.7	5.4	4.5	85	8.6	6.5	5.2	4.3	
OC-04 (50)	30	91	7.6	5.7	4.6	3.8	93	7.5	5.6	4.5	3.7	
	40	93	8.5	6.4	5.1	4.3	94	8.4	6.3	5.1	4.2	
	60	94	10.3	7.7	6.2	5.2	95	10.2	7.7	6.1	5.1	
OC-06 (50)	30	99	10.4	7.8	6.2	5.2	108	9.5	7.2	5.7	4.8	
	40	101	11.8	8.8	7.1	5.9	110	10.8	8.1	6.5	5.4	
	60	102	14.2	10.6	8.5	7.1	111	13.0	9.8	7.8	6.5	
OC-08 (50)	30	100	13.7	10.2	8.2	6.8	110	12.4	9.3	7.5	6.2	
	40	102	15.5	11.6	9.3	7.8	112	14.1	10.6	8.5	7.1	
	60	104	18.7	14.0	11.2	9.3	113	17.2	12.9	10.3	8.6	
OC-12	30	102	20	15.1	12.1	10.1	113	18.2	13.7	10.9	9.1	
	40	104	23	17.1	13.7	11.4	115	21	15.5	12.4	10.3	
	60	105	28	21	16.6	13.9	116	25	18.8	15.1	12.5	
OC-16	30	132	21	15.6	12.5	10.4	142	19.4	14.5	11.6	9.7	
	40	138	23	17.2	13.8	11.5	146	22	16.3	13.0	10.8	
	60	143	27	20	16.3	13.6	148	26	19.7	15.7	13.1	

Note: Always double check your application rates. See pages 149-163 for useful formulas and information.

