

Manuel de l'utilisateur / Operator's manual
Manuel de pièce / Parts manual



Série C

Pulvérisateur - Traitement / arrosage
Sprayer - Treatment / watering



LISTE DES RUBRIQUES • LIST OF CONTENTS

INTRODUCTION

POLITIQUE DE GARANTIE

ENTRETIEN / REMISAGE

MÉTHODE DE CALIBRATION

SCHÉMA D'ASSEMBLAGE

VUES EXPLOSÉES DES COMPOSANTES

INTRODUCTION

WARRANTY POLICY

MAINTENANCE / STORAGE

CALIBRATION METHOD

DRAWING ASSEMBLY

PARTS BREAK DOWN

INTRODUCTION

Merci d'avoir choisi un produit de qualité de MS Gregson inc. Nous sommes heureux de vous compter parmi les propriétaires satisfaits de nos pulvérisateurs.

Plusieurs années de recherche ont mené au développement de cette série de modèles et seulement des pièces et matériaux de qualité sont utilisés. Chaque machine est soigneusement testée et inspectée avant de quitter notre usine pour vous assurer des années de performance.

Pour une performance continue, souvenez-vous que cette machine représente un important investissement de votre part mais, bien entretenue, elle vous retournera votre investissement plus d'une fois. Comme pour tous les équipements mécaniques, votre machine requiert une installation adéquate, une bonne opération et l'entretien spécifié dans ce manuel.

Veuillez lire ce manuel très attentivement et au complet avant d'installer et d'opérer votre machine. Examinez votre machine, ses accessoires et la caisse d'emballage pour noter tout dommage ou pièce manquante. Rapportez rapidement au transporteur toute réclamation pour perte ou dommage.

Thank you for having selected a quality MS Gregson Inc. product. We are pleased to have you included among the many satisfied owners of our sprayers.

Years of research have brought into the development of these fine products and only top quality components and materials are used throughout. Every machine is carefully tested and inspected before leaving our plant to ensure you years of performance.

For a continuous performance, remember that this washer is a substantial investment for you, but properly cared and maintained it will return this investment many times. As with all mechanical equipment, your washer requires proper installation, proper operation and maintenance as specified in this manual.

Please read carefully the entire manual before installing and operating this machine. Examine machine, accessories and crate carefully for shipping damage or missing parts. Report promptly any shortages or damage claims to freight carrier.

POLITIQUE DE GARANTIE • WARRANTY POLICY

GARANTIE LIMITÉE

Les machines fabriqués par MS Gregson inc. sont garantis, à l'acheteur initial au détail, comme étant exempts de vices de matériaux ou de fabrication pour les délais spécifiés ci-dessous. Les conditions d'utilisation normale conformes aux instructions décrites dans le manuel de l'utilisateur s'appliquent. Cette garantie limitée est sujette aux exclusions ci-dessous énumérées. Elle est calculée à partir de la date de livraison à l'acheteur initial et s'applique aux composantes originales seulement. Les pièces remplacées sous cette garantie jouissent du délai restant de la garantie pour les composantes correspondantes.

GARANTIE DE 1 AN SUR LES PIÈCES, 1 AN SUR LA MAIN-D'OEUVRE

Les composantes, excluant les accessoires mentionnés ci-dessous et les items d'entretien courant mentionnés ci-dessous, sont couvertes par une garantie de 1 an sur les pièces et la main-d'oeuvre.

GARANTIE OFFERTE PAR D'AUTRES MANUFACTURIERS

Les moteurs électriques ou à essence, batteries, pneus, jantes, contrôleur de taux ou autres items dont le fabricant offre directement une garantie, sont réparés dans un centre de service autorisé du fabricant correspondant. MS Gregson inc. ne peut offrir de garantie sur ces items.

EXCLUSIONS DE LA GARANTIE

- Ajustement de routine et articles d'entretien courant tels que lubrifiants, courroies, boyaux, joints toriques, tamis de filtre, fusibles, systèmes d'étanchéité de pistolets.
- Réparation requise suite à une collision, un accident, un choc, un abus, des modifications apportées à l'équipement sans autorisation, une installation inadéquate, un mauvais entretien, une utilisation contraire aux directives fournies dans ce manuel ou au bon sens commun.
- Réparation requise suite au gel ou à l'exposition à des produits corrosifs.
- Réparation requise suite à des fluctuations de tension électrique d'alimentation.
- Réparation requise suite à une alimentation insuffisante en eau ou à une eau de mauvaise qualité.
- Dommages aux cultures dû à un mauvais calibrage ou usage de l'équipement.
- Dommages aux cultures ou déversement dû à un bris de composante et/ou un accident.
- Frais résultant de l'arrêt de l'unité durant une réparation ou pour toute autre raison.
- Frais de transport et/ou déplacement

LIMITED WARRANTY

The machines manufactured by MS Gregson inc. are warranted, to the original purchaser, to be free from defects in materials and workmanship for the periods specified below. Normal use conditions, according to the instructions in the operator's manual, apply. This limited warranty is subject to the exclusions listed below, is calculated from the date of delivery to the original purchaser, and applies to the original components only. Parts replaced under this warranty will assume the remainder of the corresponding part's warranty period.

1 YEAR PARTS, 1 YEAR LABOUR WARRANTY

The components, excluding accessories listed below and normal wear items listed below, are warranted for 1 year on parts and labour.

WARRANTY PROVIDED BY OTHER MANUFACTURERS

Motors, engines, batteries, wheels, rims, rate controller or other items which are warranted by their respective manufacturers, are serviced through these manufacturer's local authorized service centres. MS Gregson inc. cannot provide warranty on these items.

EXCLUSIONS OF WARRANTY

- Routine adjustments and normal maintenance items such as lubricants, belts, hoses, O-rings, filter screens, fuses, gun seal kits.
- Repairs required as a result of collision, accident bumping, misuse, modifications made to the equipment without authorization, incorrect installation, lack of required maintenance, use contrary to the instructions included in this manual or to the common sense.
- Repairs required as a result of freezing or exposition to corrosive products.
- Repairs required as a result of voltage fluctuations of the electric supply.
- Repairs required as a result of insufficient water supply or poor quality water.
- Damage to crop due to wrong calibration or incorrect use of the equipment.
- Damage to crop or spill due to components failure and/or accident.
- Additional charge resulting from paralyzation and repair of the equipment.
- Transportation and/or traveling.

POLITIQUE DE GARANTIE • WARRANTY POLICY

EXÉCUTION DE RÉPARATION PENDANT LA PÉRIODE DE GARANTIE

Pour obtenir le service de garantie sur des pièces garanties par MS Gregson inc. pendant la période de garantie, vous devez montrer à votre concessionnaire une preuve d'achat de votre équipement. Si l'équipement est installé de façon permanente, les réparations seront effectuées sur place par le concessionnaire. Pour obtenir le service de garantie sur les composantes garanties par d'autres fabricants, votre concessionnaire peut vous aider à obtenir ces services dans un centre local de service autorisé.

Le concessionnaire a la responsabilité d'effectuer les réparations couvertes pendant la durée de la garantie.

Ces réparations se feront à l'atelier du concessionnaire pour les équipements mobiles ou chez le client au choix du concessionnaire ; le client au détail a la responsabilité d'apporter son équipement chez son concessionnaire.

Les pièces changées sous garantie deviennent la propriété de MS Gregson inc.

LIMITE DE LA RESPONSABILITÉ

La responsabilité de MS Gregson inc. pour les dommages particuliers, accidentels ou consécutifs est expressément déniée. En aucun temps, la responsabilité de MS Gregson inc. ne peut excéder le prix d'achat du produit en question. LA PRÉSENTE GARANTIE TIENT LIEU DE TOUTE AUTRE GARANTIE, EXPLICITE OU IMPLICITE, Y COMPRIS TOUTE GARANTIE IMPLICITE D'ADAPTATION POUR UNE UTILISATION PARTICULIÈRE. MS Gregson inc. n'autorise aucune autre partie, incluant les concessionnaires MS Gregson autorisés, à faire toute représentation ou promesse au nom de MS Gregson inc. ou à modifier les termes, conditions ou limitations d'aucune façon. Il est de la responsabilité de l'acheteur de s'assurer que l'installation et l'utilisation des produits MS Gregson respectent les codes locaux. Bien que MS Gregson inc. tente de s'assurer que ses produits rencontrent les codes nationaux, elle ne peut être responsable de la façon dont le client choisit d'installer ou d'utiliser le produit.

EXECUTION OF REPAIRS WITHIN THE WARRANTY PERIOD

In order to obtain warranty service on items warranted by MS Gregson inc. within the warranty period, you must show to your dealer a proof of purchase. If the equipment is permanently installed, repairs will be carried out on the spot by the dealer. For warranty service on components warranted by other manufacturers, your authorized MS dealer can help you obtain warranty service through these manufacturers' local authorized service centres.

The dealer has the responsibility to carry out repairs within the warranty period.

Repairs will be done at the dealer's repair-shop for mobile equipments (or at your site upon dealer choice); the purchaser has the responsibility to bring his equipment to his dealer's repair-shop.

The parts changed under warranty become the property of MS Gregson inc.

LIMITATION OF LIABILITY

MS Gregson inc. liability for special, incidental, or consequential damages is expressly disclaimed. In no event shall MS Gregson inc. liability exceed the purchase price of the product in question. THE WARRANTY CONTAINED HEREIN IS IN LIEU OF ALL OTHER WARRANTIES, EXPRESSED OR IMPLIED, INCLUDING ANY IMPLIED WARRANTY OF FITNESS FOR A PARTICULAR PURPOSE. MS Gregson inc. does not authorize any other party, including authorized MS Gregson dealers, to make any representation or promise on behalf of MS Gregson inc. or to modify the terms, conditions, or limitations in any way. It is the buyer's responsibility to ensure that the installation and use of MS Gregson products conforms to local codes. While MS Gregson inc. attempts to assure that its products meet national codes, it cannot be responsible for how the customer chooses to use or install the product.

ENTRETIEN / REMISAGE • MAINTENANCE / STORAGE

IMPORTANT :

Rincer le réservoir de l'unité et la plomberie avec de l'eau claire après chaque utilisation (voir ENTRETIEN / REMISAGE).

REMISAGE

Rincer et drainer le réservoir, la rampe, les tubes, les boyaux ainsi que la pompe.

Faire fonctionner l'unité en aspirant une solution d'antigel (prestone) de façon à ce qu'elle en soit complètement rempli (boyaux et pompe).

NOTE : ne pas utiliser de liquide lave vitre.

Enlever la base et le tamis du filtre.

Enlever le cadran à pression et remiser au chaud (ne supporte pas le gel).

S'assurer qu'il ne reste plus de liquide dans les filtres.

Avant de mettre à nouveau l'unité en marche, bien vider et laver le réservoir, les boyaux et la pompe.

IMPORTANT :

Rinse the unit tank and the plumbing with clear water after each use (see MAINTENANCE / STORAGE).

STORAGE

Rinse and drain the tank, the boom, the tubes, the hoses and the pump.

Operate the system by sucking an anti-freeze (prestone) solution through the hoses and the pump.

NOTE: Do not use windshield washer fluid.

Take-off base and filter screen.

Take-off pressure gage and put it in a warm place (it does not support freezing).

Make sure that no liquid is left into the filters.

Before starting the unit again, be sure that the tank, hoses and pump are well emptied and washed.

ENTRETIEN / REMISAGE

Pompe :

Rincer avec de l'eau claire après chaque utilisation spécialement après une pulvérisation avec de l'engrais liquide, un insecticide ou un fongicide. Toujours porter un équipement de protection.

Filtre d'alimentation :

Vérifier et nettoyer régulièrement le filtre d'alimentation d'eau dans le réservoir.

Buses :

Vérifier et nettoyer régulièrement les buses pour éviter tout colmatage ou diminution de débit.

Nettoyage :

Nettoyer tous les filtres avant de commencer cette étape. Laver et rincer avec un produit neutralisant tous les équipements ayant été en contact direct ou indirect tel que l'embrun pour éviter tout risque de contamination lors de la manutention et l'entreposage.

Consulter le fournisseur de produits sanitaire pour les produits de nettoyage et de neutralisation pour pulvérisateur. Nettoyer tous les filtres à nouveau.

Toujours nettoyer les équipements de pulvérisation dans un endroit bien aéré et non-cultivé et loin des sources d'eau potable. Consulter les instances agricoles locales pour les moyens à prendre et les règles à suivre pour éviter toute contamination des sources d'eau potable, enfants et animaux domestiques.

MAINTENANCE / STORAGE

Pump:

Rinse after each use with clear water especially if you use a liquid fertilizer, an insecticide or a fungicide. Always wear protective clothing.

Suction filter:

Regularly check and clean the suction water filter in the tank.

Nozzles:

Regularly check and clean nozzles to avoid plugging and lower flow rate.

Cleaning:

Clean all filters before starting this operation. Clean and wash with neutralizing product all the equipment that has been in direct or indirect contact with drift to avoid contamination in handling or storage.

Consult your product suppliers to obtain cleaning and neutralizing product for sprayer. Clean all the filters again.

Always clean the sprayer equipment in a ventilated area and non-cultivated area away from water source. Contact local agricultural authorities for advice on disposal and laws to avoid contamination of water source, kids and pets.

MÉTHODE DE CALIBRATION • CALIBRATION METHOD

Méthode de calibration pour fertilisation de gazon

Une bonne méthode de calibration pour la fertilisation des pelouses doit tenir compte de ces 3 facteurs :

- 1- Superficie couverte en 60 secondes.
- 2- Vitesse d'avancement.
- 3- Débit du pistolet pendant 60 secondes.

L'utilisateur doit traiter une superficie fixe durant 60 secondes, habituellement 100 m² or 1000 pi².

Avec le fusil Lesco ou TeeJet, on couvre habituellement 8 pi de largeur ou 2.44 mètres. Il faut donc parcourir 41 mètres (134') en 60 secondes pour couvrir 100 m²/min ou 125 pi (38 m) en 60 secondes pour couvrir 1000 pi²/min.

Avec le fusil à gazon MS, on couvre habituellement 6 pi de largeur ou 1.83 mètres. Il faut donc parcourir 54.6 mètres (179') en 60 secondes pour couvrir 100m²/min. ou 167 pi (51 m) en 60 secondes pour couvrir 1000 pi²/min.

Débit du pistolet pendant 60 secondes :

Ajuster votre pression à la pompe afin d'avoir le débit désiré à la buse. Vous recueillez le produit de la buse dans un récipient calibré, pendant 60 secondes d'écoulement.
(ex : 12L/min.)

Lawn spraying calibration method

A good calibration method for lawn spraying must keep track of these 3 facts :

- 1- Area covered during 60 seconds
- 2- Walking speed
- 3- Gun rate during 60 seconds

The operator must spray a fixed area during 60 seconds, usually 100 m² or 1000 ft².

With the Lesco or TeeJet gun, you usually spray a swath of 8 ft or 2.44 m. The distance is 41 meters (134') in 60 seconds to cover 100 m²/min. or 125 ft (38 m) in 60 seconds to cover 1000 ft² / min.

With the MS lawn gun, you usually spray a swath of 6 ft or 1.83 m. The distance is 54.6 meters (179') in 60 seconds to cover 100 m²/min. or 167 ft (51 m) in 60 seconds to cover 1000 ft² / min.

Gun rate during 60 seconds:

Adjust your pump pressure to get your desired rate at the gun. Collect the liquid from the nozzle during 60 seconds into a calibration jar. (ex : 4 GPM)

Chartes de buses / gazon Buse - Nozzles	Lawn nozzles chart Débit - Rate
MS, laiton/brass, # LE-006328	10 L/min. == 2.65 GPM
Teejet, grise – gray, # JB-2567015NY	5.6-13L/min. == 1.5 – 3.4 GPM
Teejet, noire – black, # JB-2567030NY	7.5-18L/min. == 2 – 4.7 GPM
Teejet, rouge – red, # JB-2567040NY	9 – 21L/min. == 2.4 – 5.5 GPM
Lesco, jaune – yellow, # LE-009510	5.6-13L/min. == 1.5 – 3.4 GPM
Lesco, verte – green, # LE-007668	7.5-18L/min. == 2 – 4.7 GPM
Lesco, blanche – white, # LE-007655	9 – 21L/min. == 2.4 – 5.5 GPM

Note : GPM = gal (US)/min.

CALIBRATION PELOUSE 4 gal/min/1000 pi ²				
Système	Débit buse	Taux	Vitesse	Largeur d'application
US :	4 gal/min	4 gal/1000 pi ²	125 pi/min	8 pi
Métrique :	15 L/min	15 L/100 m ²	41 m/min	2,44 m

LAWN-CARE APPLICATION RATE - 4 GPM/1000 ft ²				
System	Nozzle rate	Rate	Speed	Width band
US :	4 gpm	4 gal/1000 ft ²	125 ft/min	8 ft
Metric :	15 L/min	15 L/100 m ²	41 m/min	2,44 m

SCHEMA D'ASSEMBLAGE • DRAWING ASSEMBLY

#	REF.	Q.	L"
10	SN-TS198	1	216 in

#	REF.	Q.
1	C010-RY00300A	1
2	C010-0006	2
3	BT-381	4
4	BT-FW38	8
5	BT-LN38	4
6	BT-124FL	4
7	MS-AC01	4
8	BT-FW12	4
9	BT-LN12	4
10	SN-TS198	1

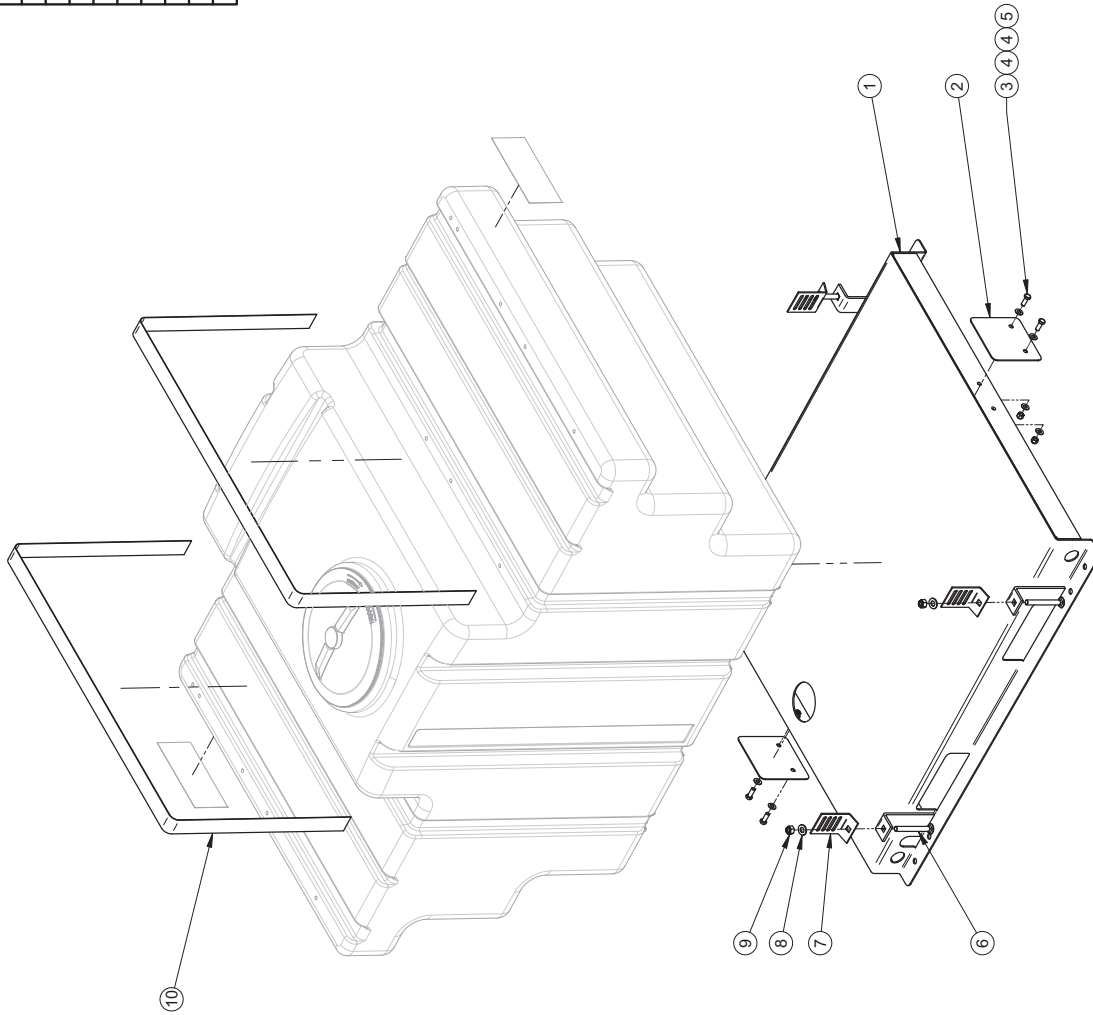

Rev	Description	Date	Approbation
Rev 1	Réservoir et châssis en référence seulement (option châssis série C)	2020-02-19 (trudej)	
Rev			

<p>Tous les valeurs sont en unités métriques sauf indication contraire.</p> <p>ALL VALUES ARE IN METRIC UNITS UNLESS OTHERWISE SPECIFIED.</p> <p>GENERAL TOLERANCES: Angles: 1° ± 0.1°; XX: ± 0.1"; XXX: ± 0.005"</p>	<p>MSG M S G R E G S O N</p>	<p>AVB: l'information technique à été conçue par et/ou propriété exclusive de la société MSG. Toute réimpression, utilisation, copie ou reproduction sans autorisation écrite est formellement interdite.</p> <p>MSG reserves the right to change specifications without notice. All rights reserved. No part of this publication may be reproduced, stored in a retrieval system, or transmitted in any form or by any means, electronic, mechanical, photocopying, recording, or by any information storage and retrieval system, without the prior written permission of MSG.</p>	<p># FEUILLE / SHEET # CR040-RY00300A</p> <p>DESCRIPTION Ensemble châssis pour réservoir 300 gal série C300</p> <p>#DESSIN / DRAWING # CR040-RY00300A</p>	<p>DATE CREATION 2018-11-02</p> <p>CREATEUR / CREATOR trudej</p>	<p>REVISION DATE 2020-02-19</p> <p>REVISION PAR / BY trudej</p> <p>ECHELLE / SCALE 1:16.67</p>	<p>PAGE 1 of 1</p> <p>REVISION 1</p>
---	------------------------------	--	---	--	--	--------------------------------------

SCHEMA D'ASSEMBLAGE • DRAWING ASSEMBLY

#	REF.	Q.	L"
1	SN-TS198	1	204 in

#	REF.	Q.
2	BT-LN12	4
3	BT-FW12	4
4	MS-AC01	4
5	BT-124FL	4
6	C010-RY00400D	1
7	BT-383	8
8	BT-FW38	16
9	BT-LN38	8
10	C010-RY00400C	1
11	C010-RY00400E	1

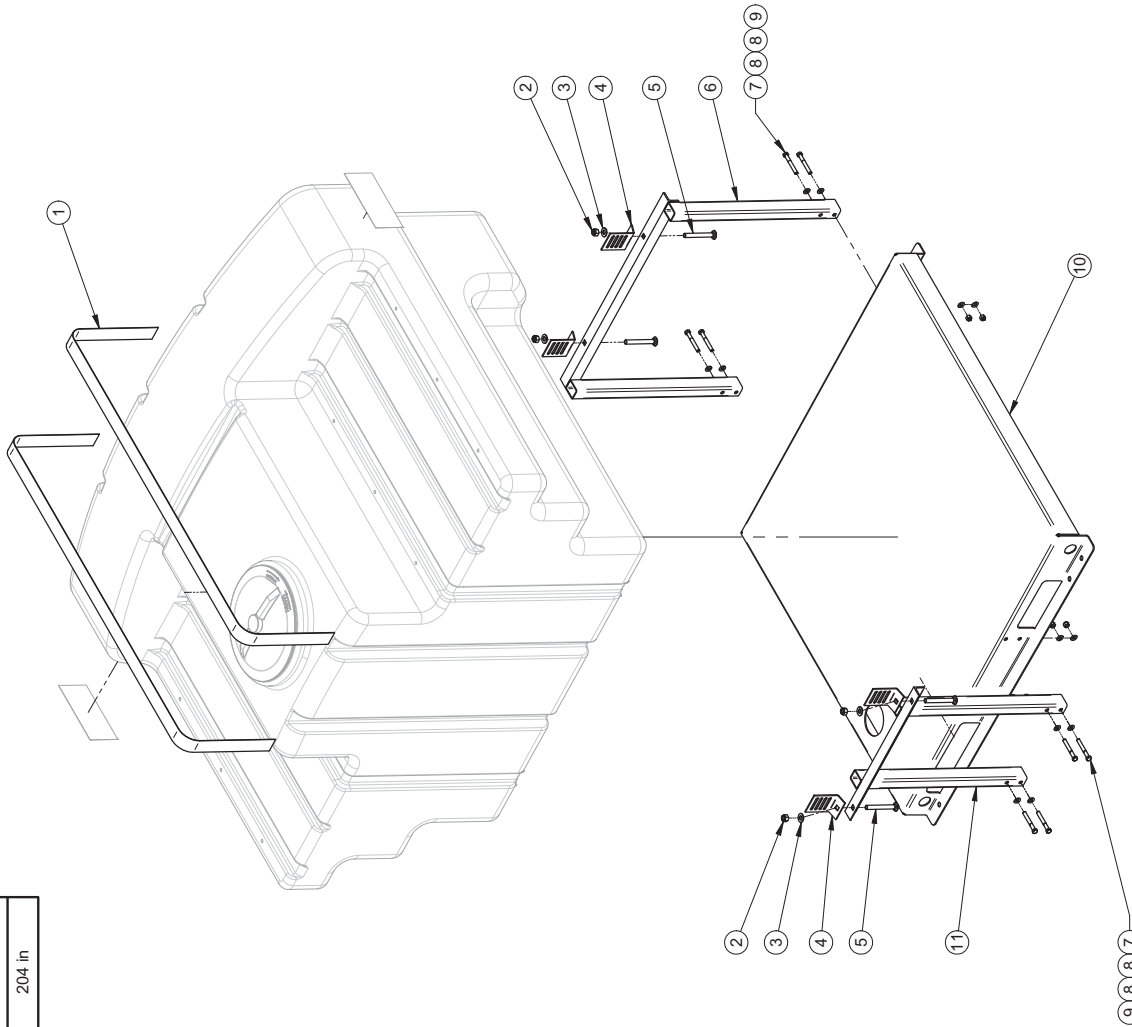

<p>1- LES VALEURS SONT EN POUCE SAUF SI SPECIFIE UNITS ARE IN INCHES 2- TOLERANCES GENERALES GEN. TOL. : Angles: ± 1° XXX ± 0.01" XXXX ± 0.005"</p>		<p># FEUILLE / SHEET # CR040-RY00400B</p>	<p>DATE CREATION 2020-03-10</p>	<p>CREATEUR / CREATOR trudej</p>	<p>REVISION DATE 2020-03-11</p>	<p>PAGE 1 of 1</p>								
<p>AVIS: Information d'origine AMB de MS GREGGON. Tous les droits de propriété, licence, commercialisation, fabrication et tout autre sont réservés. NOTICE: Information disclosed herein is the property of MS GREGGON. All rights reserved. All other rights reserved.</p>		<p>DESCRIPTION Ensemble châssis pour réservoir 400 gal série C400 - version inclinée</p>	<p>REVISION PAR / BY trudej</p>	<p>ECHELLE / SCALE 1:20</p>	<p>REVISION 0</p>									
<p>MS GREGGON</p>		<p>#DESSIN / DRAWING # CR040-RY00400B</p>	<table border="1"> <thead> <tr> <th>Rev</th> <th>Description</th> <th>Date</th> <th>Approbation</th> </tr> </thead> <tbody> <tr> <td> </td> <td> </td> <td> </td> <td> </td> </tr> </tbody> </table>				Rev	Description	Date	Approbation				
Rev	Description	Date	Approbation											

SCHEMA D'ASSEMBLAGE • DRAWING ASSEMBLY

#	REF.	Q.
1	MP-2200301	1
2	MP-1163201	1
3	DA-SHAS12	2
4	JB-IMB0606NY	1
5	DA-WASHER	1
6	MP-210030	1

#	REF.	Q.	L"
7	LV-342N	1	96 in

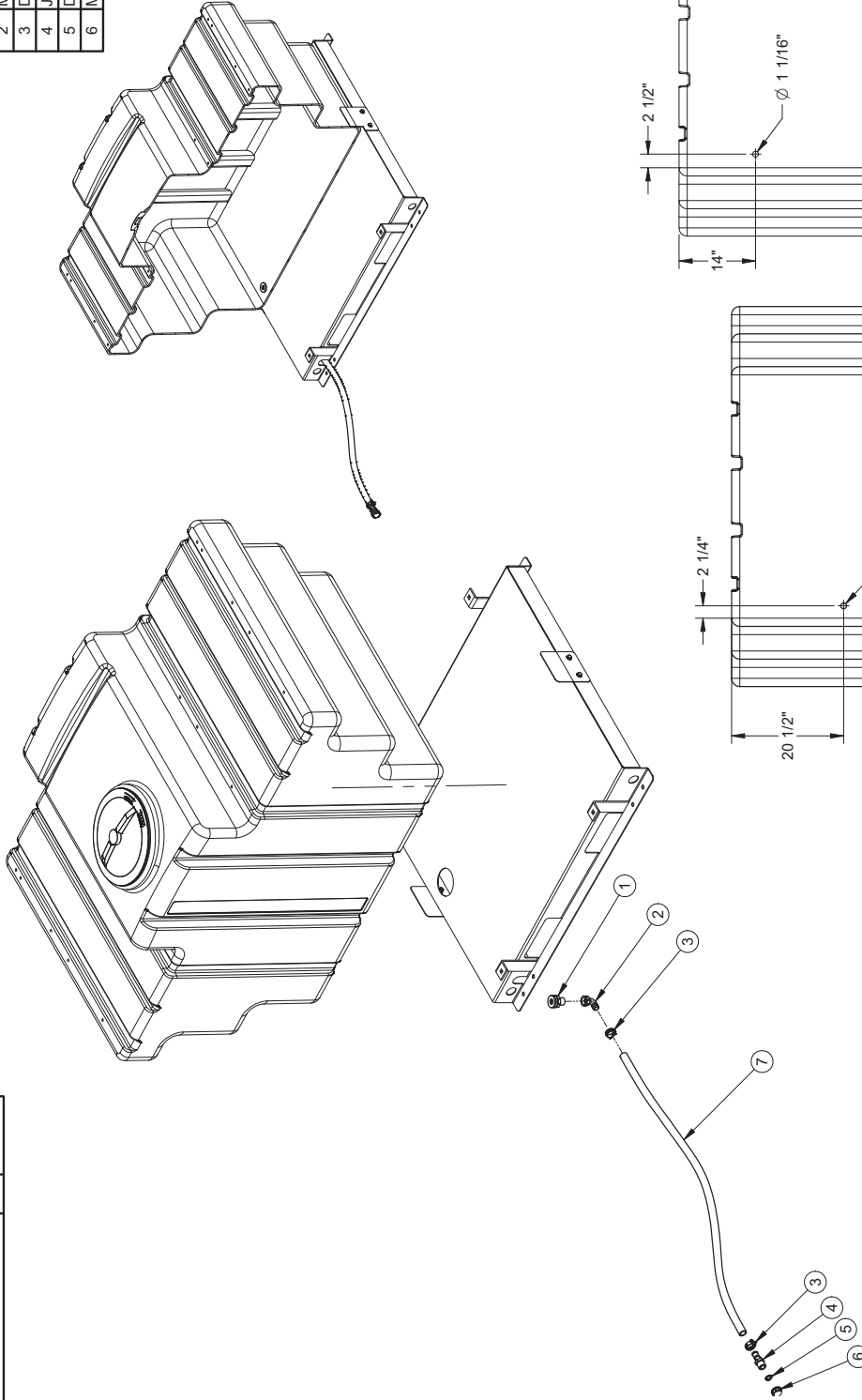

C400 - PERÇAGE DU RÉSERVOIR

C300 - PERÇAGE DU RÉSERVOIR

Rev	Description	Date	Approbation
1	Ajouter perçage drain pour réservoir C400	2-03-2020 (trudej)	

# FEUILLE / SHEET #	DATE CREATION	CREATEUR / CREATOR	REVISION DATE	PAGE
CR370-0010	2018-11-08	trudej	2020-03-26	1 of 1

DESCRIPTION	REVISION PAR / BY	REVISION
Ensemble de drainage 3/4" pour C300 et C400	trudej	

#DESSIN / DRAWING #	ECHELLE / SCALE
CR370-0010	1:22.22

AVIS	REVISION
Tous droits réservés. Toute réimpression ou utilisation non autorisée sans la permission écrite de la société est formellement interdite. Toute réimpression ou utilisation non autorisée sans la permission écrite de la société est formellement interdite.	1 1:22.22

SCHEMA D'ASSEMBLAGE • DRAWING ASSEMBLY

#	REF.	Q.
1	AU-DECC200	2
2	AU-PNS3-G	1
3	C360-0043	1
4	BT-3834	6
5	BT-LW38	12
6	BT-FW38	30
7	AC-SSPU0200-70	1
8	MP-210040	1
9	MP-G40002	1
10	MP-2200401	1
11	C350-0019	1
12	BT-381	6
13	BT-CAR516114	4
14	BT-FW516	8
15	BT-N516	4
16	BT-LW516	4

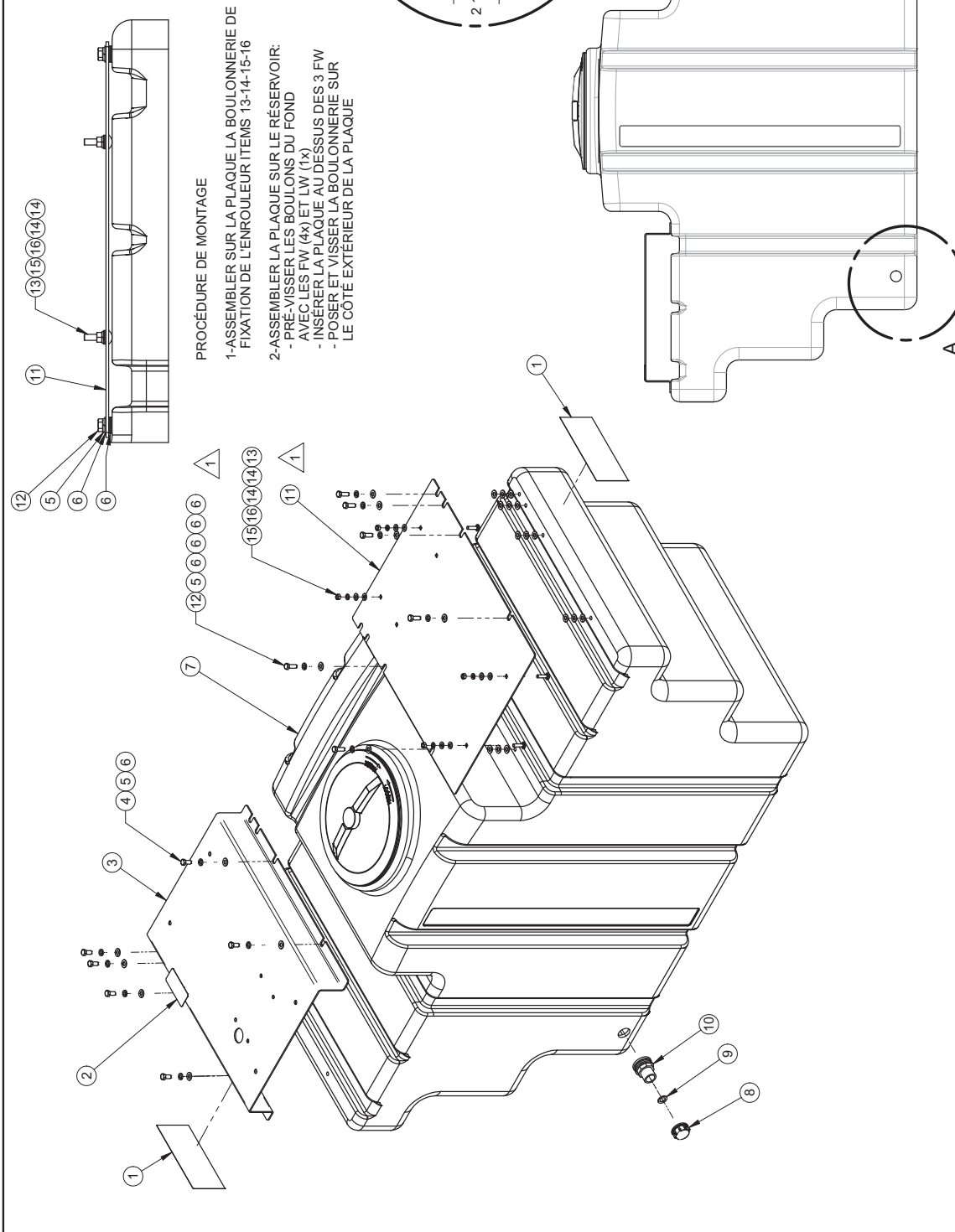

PROCÉDURE DE MONTAGE

1-ASSEMBLER SUR LA PLAQUE LA BOULONNERIE DE FIXATION DE L'ENROULEUR ITEMS 13-14-15-16

2-ASSEMBLER LA PLAQUE SUR LE RÉSERVOIR:
 - PRÉ-VISSER LES BLOONS DU FOND
 - AVEC LES FW (4X) ET LW (1X)
 - INSERER LA PLAQUE AU DESSUS DES 3 FW
 - POSER ET VISSER LA BOULONNERIE SUR LE CÔTÉ EXTERIEUR DE LA PLAQUE

REV	DESCRIPTION	DATE CREATION	CREATEUR / CREATOR	REVISION DATE	PAGE
Rev 1	C360-0019 et C360-0043 et modifier la boulonnerie	2020-06-11	trudej	2020-08-28	1 of 1
Rev	Description				

#	FEUILLE / SHEET #	DATE CREATION	CREATEUR / CREATOR	REVISION DATE	PAGE
1	CR370-0025	2020-06-11	trudej	2020-08-28	1 of 1

DESCRIPTION	REVISION PAR / BY	REVISION DATE	REVISION SCALE
Réserveir et drainage 1" pour C200	trudej		
DESIGN / DRAWING #			
CR370-0025			1:14.29

ALL INFORMATION CONTAINED HEREIN IS THE PROPERTY OF M.S.G. REGSON. IT IS TO BE USED FOR THE PURPOSES SPECIFIED ONLY. IT IS TO BE KEPT IN CONFIDENTIALITY AND NOT TO BE REPRODUCED OR TRANSMITTED IN ANY FORM OR BY ANY MEANS, ELECTRONIC OR MECHANICAL, INCLUDING PHOTOCOPYING, RECORDING, OR BY ANY INFORMATION STORAGE AND RETRIEVAL SYSTEM. WITHOUT THE WRITTEN PERMISSION OF M.S.G. REGSON, THIS DOCUMENT IS TO BE DESTROYED.
<p>M.S.G. REGSON</p> <p>LES VALEURS SONT EN VALUES ARE IN INCHES UNITS ARE IN INCHES GENERAL TOLERANCES FRACTIONS: ± 1/16" DECIMALS: ± 0.1" ANGLES: ± 1° HOLE POSITION: ± 0.005" SURF FINISH: XXXX ± 0.005"</p>

SCHEMA D'ASSEMBLAGE • DRAWING ASSEMBLY

#	REF.	Q.
1	AU-DECC300	2
2	AU-PNS3-G	1
3	C360-0027	1
4	BT-3834	6
5	BT-LW38	12
6	BT-FW38	30
7	AC-SSPU0300-70	1
8	MP-210040	1
9	MP-G40002	1
10	MP-2200401	1
11	C350-0018	1
12	BT-381	6
13	BT-CAR516114	4
14	BT-FW516	8
15	BT-N516	4
16	BT-LW516	4

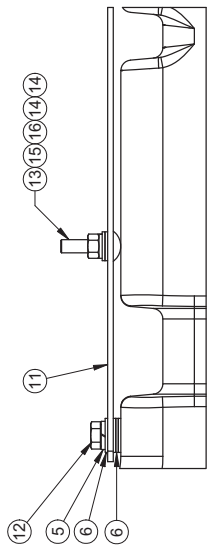

PROCÉDURE DE MONTAGE

- 1-ASSEMBLER SUR LA PLAQUE LA BOULONNERIE DE FIXATION DE L'ENROULEUR ITEMS 13-14-15-16
- 2-ASSEMBLER LA PLAQUE SUR LE RÉSERVOIR:
 - PRÉ-VISSER LES BOULONS DU FOND AVEC LES FW (4x) ET LW (1x)
 - INSÉRER LA PLAQUE AU DESSUS DES 3 FW
 - POSER ET VISSER LA BOULONNERIE SUR LE CÔTÉ EXTÉRIEUR DE LA PLAQUE

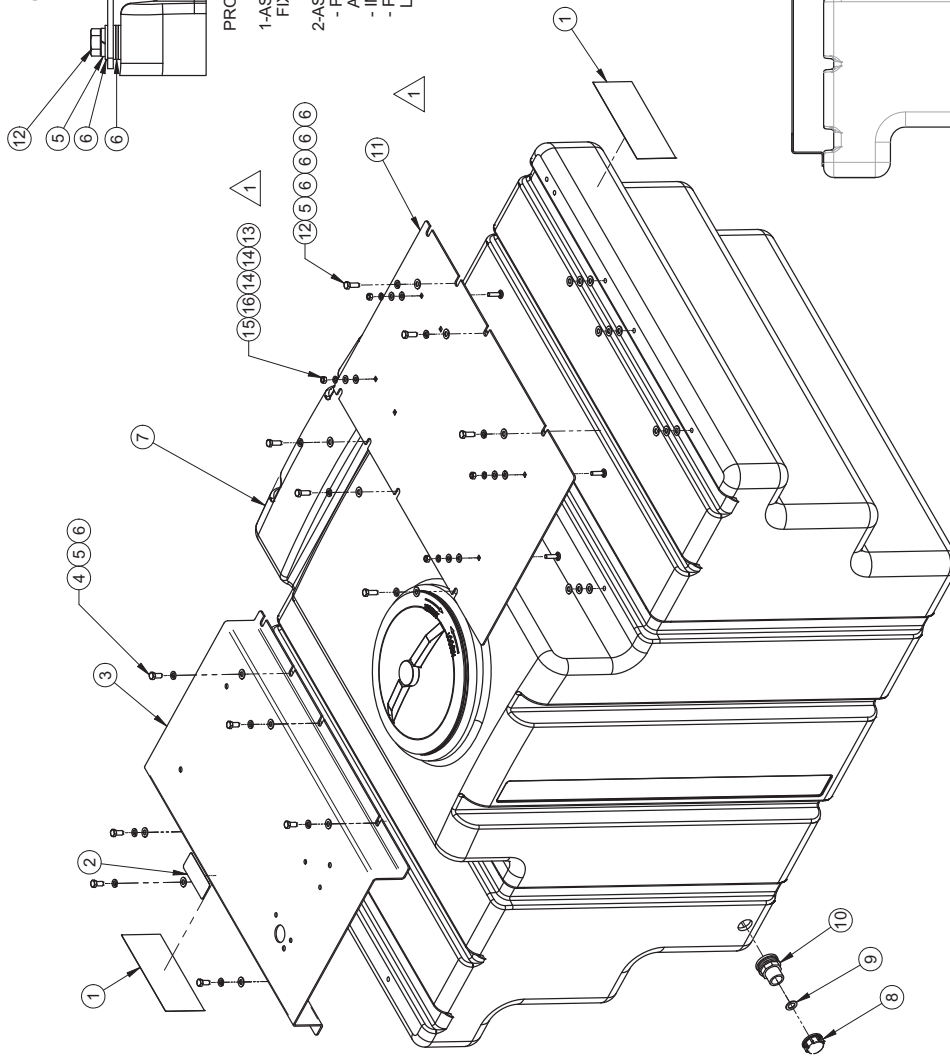

DETAIL A
1:7.14

Rev	Description	Date	Approbation
Rev 1	C350-0018 sheet C360-0027 et modifier la boulonnerie	2020-08-28 (trudelj)	
Rev	Revisions		

# FEUILLE / SHEET #	DATE CREATION	CREATEUR / CREATOR	REVISION DATE	PAGE
CR370-0015	2020-02-20	trudelj	2020-08-28	1 of 1
DESCRIPTION			REVISION PAR / BY	REVISION
Réservoir et drainage 1" pour C300			trudelj	
#RESSIN / DRAWING #			ECHELLE / SCALE	REVISION
CR370-0015			1:14.29	1

1- LES VALEURS SONT EN POUCES SAUF SI SPÉCIFIÉ	
UNLESS SPECIFIED, DIMENSIONS ARE IN INCHES	
2- GENERAL TOLERANCES	
Fine: ± 0.005"	Medium: ± 0.010"
Coarse: ± 0.015"	Maximum: ± 0.030"

AVIS: Information disclosed herein is the property of M S G REGSON, and its release, reuse, or reproduction, without written permission, is prohibited.	
NOTICE: Information disclosed herein is the property of M S G REGSON, who reserves all patent rights, trademarks, and other intellectual property rights therein.	

SCHEMA D'ASSEMBLAGE • DRAWING ASSEMBLY

#	REF.	Q.
1	AU-DECC400	2
2	AU-PNS3-G	1
3	C360-0027	1
4	BT-3834	6
5	BT-LW38	12
6	BT-FW38	30
7	AC-SSPU0400-70	1
8	MP-210040	1
9	MP-G40002	1
10	MP-2200401	1
11	C350-0018	1
12	BT-381	6
13	BT-CAR516114	4
14	BT-FW516	8
15	BT-N516	4
16	BT-LW516	4

PROCEDURE DE MONTAGE

1-ASSEMBLER SUR LA PLAQUE LA BOULONNERIE DE FIXATION DE L'ENROULEUR ITEMS 13-14-15-16

2-ASSEMBLER LA PLAQUE SUR LE RESERVOIR:
 - PRE-VISSER LES BOULONS DU FOND AVEC LES FW (4x) ET LW (1x)
 - INSERER LA PLAQUE AU DESSUS DES 3 FW
 - POSER ET VISSER LA BOULONNERIE SUR LE COTE EXTERIEUR DE LA PLAQUE

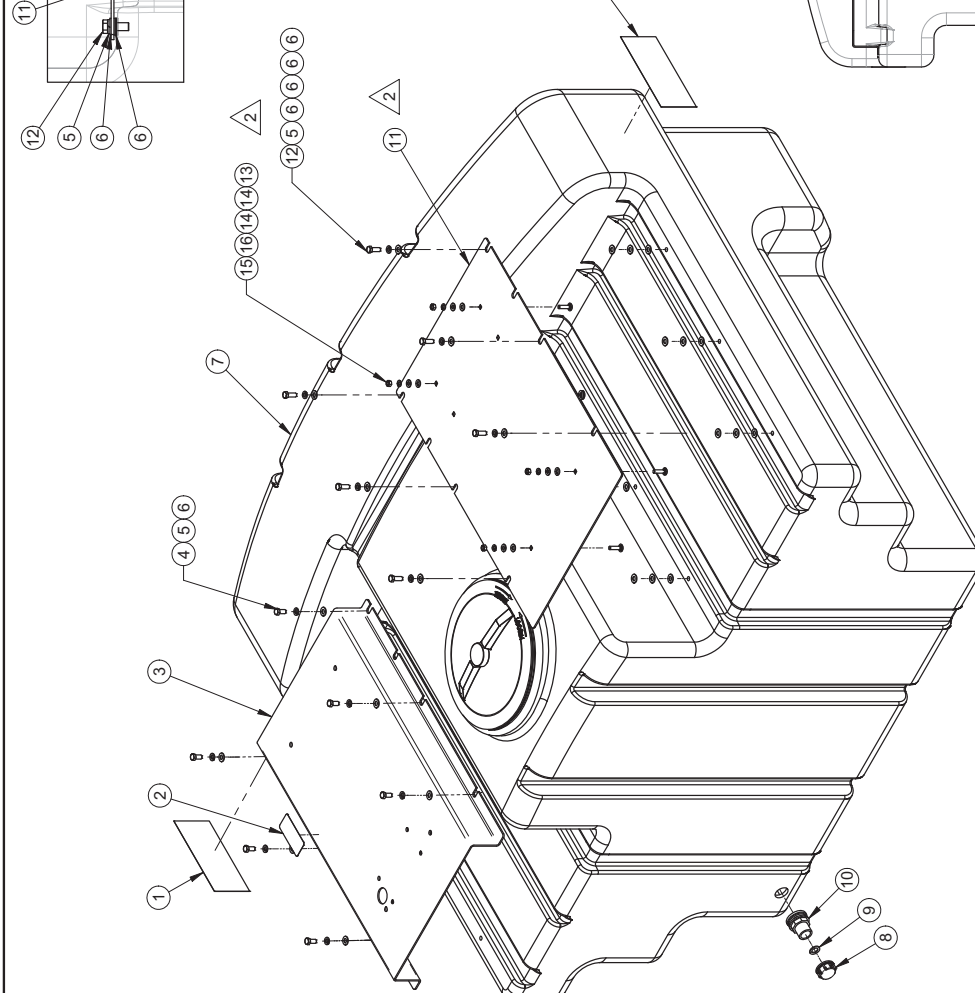

DETAIL A
1:9.09

REV	DESCRIPTION	DATE	CREATEUR / CREATOR	REVISION DATE	PAGE
Rev 2	308-2016 état C360-0027 et modifier à boulonnerie	2020-08-28	trudefej	2020-08-28	1 of 1
Rev 1	Modification de drain, changement du chassis (version initiale)	2020-03-11	trudefej		
Rev	Description	Date	Approbation		

ANS Information contained herein is for the use of the customer only and is not to be reproduced, stored in a retrieval system, or transmitted in any form or by any means, electronic, mechanical, photocopying, recording, or by any information storage or retrieval system, without the prior written permission of the manufacturer.	# FEUILLE / SHEET # CR370-0017	DATE CREATION 2020-02-25	CREATEUR / CREATOR trudefej	REVISION DATE 2020-08-28	PAGE 1 of 1
1- LES VALEURS SONT EN PULGES / INCHES 2- TOLERANCES GENERALES: Angles ± 1° X.X ± 0.1" X.XXX ± 0.005"	DESCRIPTION Réservoir et drainage pour C400			REVISION PAR / BY trudefej	REVISION 2
MS GREGSON	DESSIN / DRAWING # CR370-0017		ECHELLE / SCALE 1:15.38		

SCHEMA D'ASSEMBLAGE • DRAWING ASSEMBLY

#	REF.	Q.
1	HO-GX200X2002QAPW	1
2	JB-99T0D30GRGI	1
3	BT-516112	4
4	BT-FW516	8
5	BT-LN516	4
6	DA-SHAS32	1

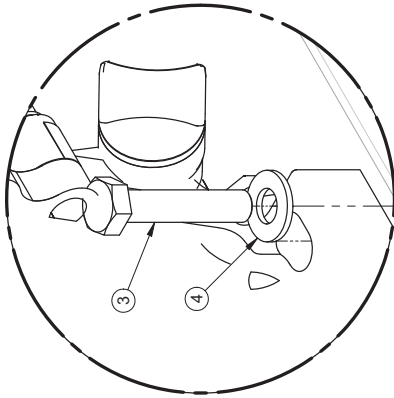

DETAIL A
1:1.6

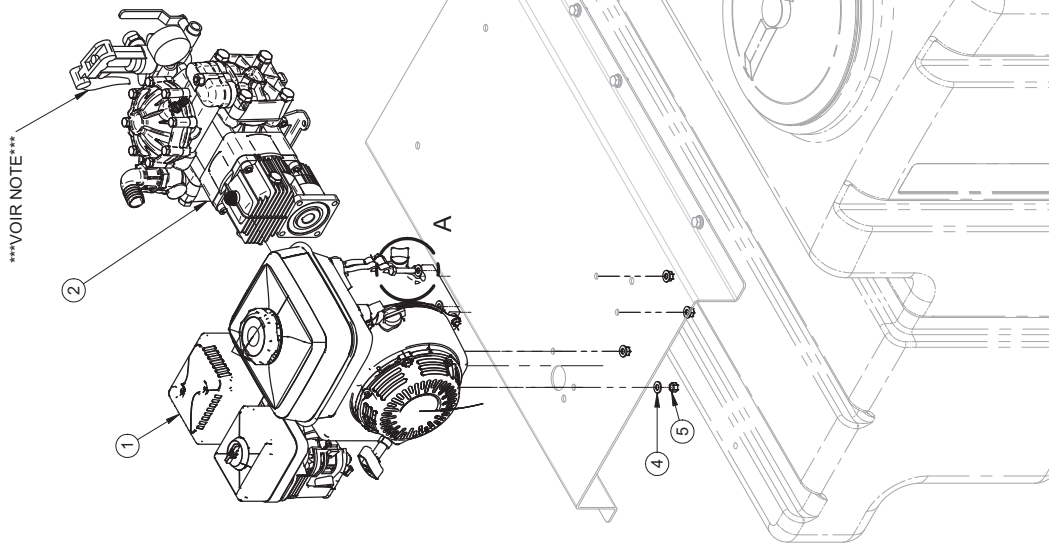

VOIR NOTE

AJUSTER LE MOTEUR À 3450 TR/MIN
 REMPLACER LE COLLET SUR LA MEMBRANE
 D'ASPIRATION PAR DA-SHAS32
 ENLEVER LA POIGNÉE ET L'EMBOUT DE LA VANNE
 DE SORTIE DU RÉGULATEUR NON UTILISÉS

Rev	Description	Date	Approbation

1- LES VALEURS SONT EN 1- VALUES ARE IN INCHES 2- TOLERANCES GÉNÉRALES 2- GENERAL TOLERANCES Angles ± 1° XX ± 0.1" XXX ± 0.1" XXXX ± 0.005"	MSG M S G R E G G S O N	AVIS: Information contenue dans ce document est la propriété exclusive de la société MSG. Toute réimpression, reproduction ou utilisation non autorisée sans la permission écrite de la société MSG est formellement interdite. Toute violation de ces droits de reproduction, de diffusion ou de propriété intellectuelle sera poursuivie devant les tribunaux. Toute utilisation non autorisée sans la permission écrite de la société MSG est formellement interdite. Toute violation de ces droits de reproduction, de diffusion ou de propriété intellectuelle sera poursuivie devant les tribunaux.	# FEUILLE / SHEET # CR360-0027	DATE CREATION 2020-02-18	CREATEUR / CREATOR trudej	REVISION DATE 2020-06-02	PAGE 1 of 1
DESCRIPTION Moteur GX200 et pompe membrane D30 assemblé		REVISION PAR / BY trudej	REVISION 0	ECHELLE / SCALE 1:10		DESIGN / DRAWING # CR360-0027	

SCHÉMA D'ASSEMBLAGE • DRAWING ASSEMBLY

#	REF.	Q.
1	HO-GX160K1QX	1
2	BU-205PO	1
3	BT-516112	4
4	BT-FW516	8
5	BT-LN516	4

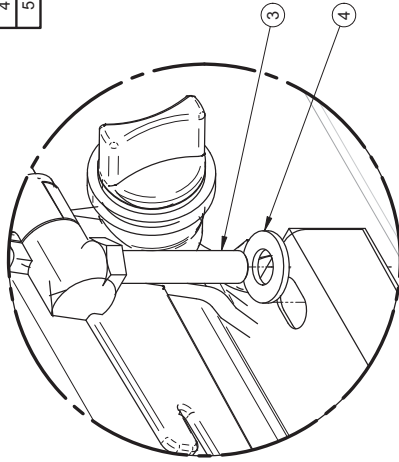

DETAIL A
1:1.6

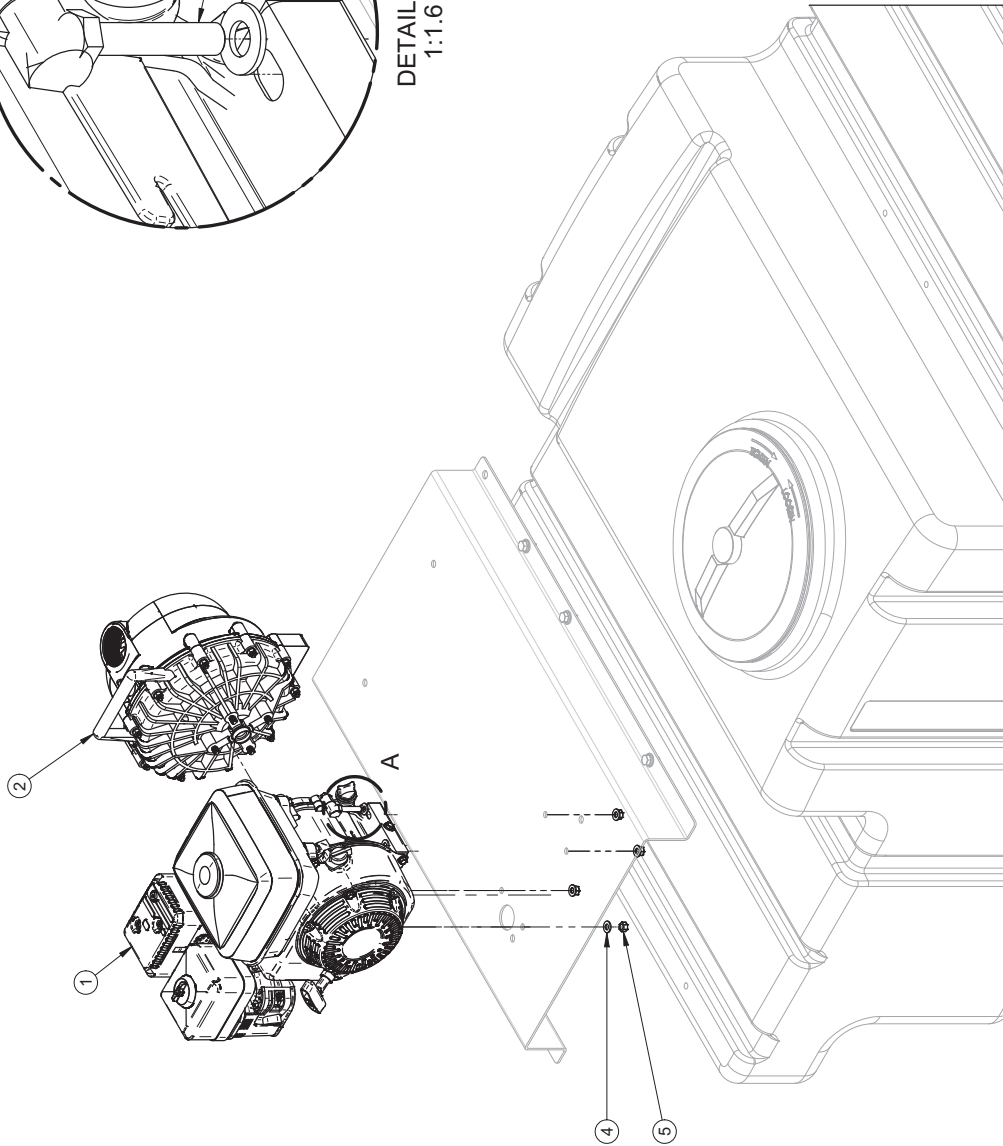

Rev	Description	Date	Approbation

1- LES VALEURS SONT EN POUCE SAUF SI SPECIFIÉ UNLESS SPECIFIED	1- LES VALEURS SONT EN POUCE SAUF SI SPECIFIÉ UNLESS SPECIFIED
2- TOLERANCES GÉNÉRALES FIG. 1: 1/16"	2- TOLERANCES GÉNÉRALES FIG. 1: 1/16"
Angles: ± 1°	Angles: ± 1°
XXX: ± 0.01"	XXX: ± 0.01"
XXXX: ± 0.005"	XXXX: ± 0.005"

MSG M S G R E G G S O N	MSG M S G R E G G S O N
MSG Information circulate a 30% de droits de propriété. Brevets réservés. Toute réimpression sans autorisation écrite de MS GREGGSON est strictement interdite. MSG Information circulate a 30% de droits de propriété. Brevets réservés. Toute réimpression sans autorisation écrite de MS GREGGSON est strictement interdite.	MSG Information circulate a 30% de droits de propriété. Brevets réservés. Toute réimpression sans autorisation écrite de MS GREGGSON est strictement interdite. MSG Information circulate a 30% de droits de propriété. Brevets réservés. Toute réimpression sans autorisation écrite de MS GREGGSON est strictement interdite.
# FEUILLE / SHEET # CR360-0029	# FEUILLE / SHEET # CR360-0029
DESCRIPTION Moteur GX160 et pompe centrifuge 2" en poly	DESCRIPTION Moteur GX160 et pompe centrifuge 2" en poly
# DRESSIN / DRAWING # CR360-0029	# DRESSIN / DRAWING # CR360-0029
DATE CREATION 2020-03-11	DATE CREATION 2020-03-11
CREATEUR / CREATOR trudej	CREATEUR / CREATOR trudej
REVISION DATE 2020-03-12	REVISION DATE 2020-03-12
REVISION PAR / BY trudej	REVISION PAR / BY trudej
ECHELLE / SCALE 1:10	ECHELLE / SCALE 1:10
REVISION 0	REVISION 0

SCHEMA D'ASSEMBLAGE • DRAWING ASSEMBLY

#	REF.	Q.	L"
9	LV-342N	1	72 in

#	REF.	Q.
1	DA-SHAS12	2
2	JB-IMB0603NY	2
3	BJ-SL0754S	1
4	JB-M3400NY	1
5	RA-5032P	1
6	JB-EL3434NY	1
7	JB-TT34NY	1

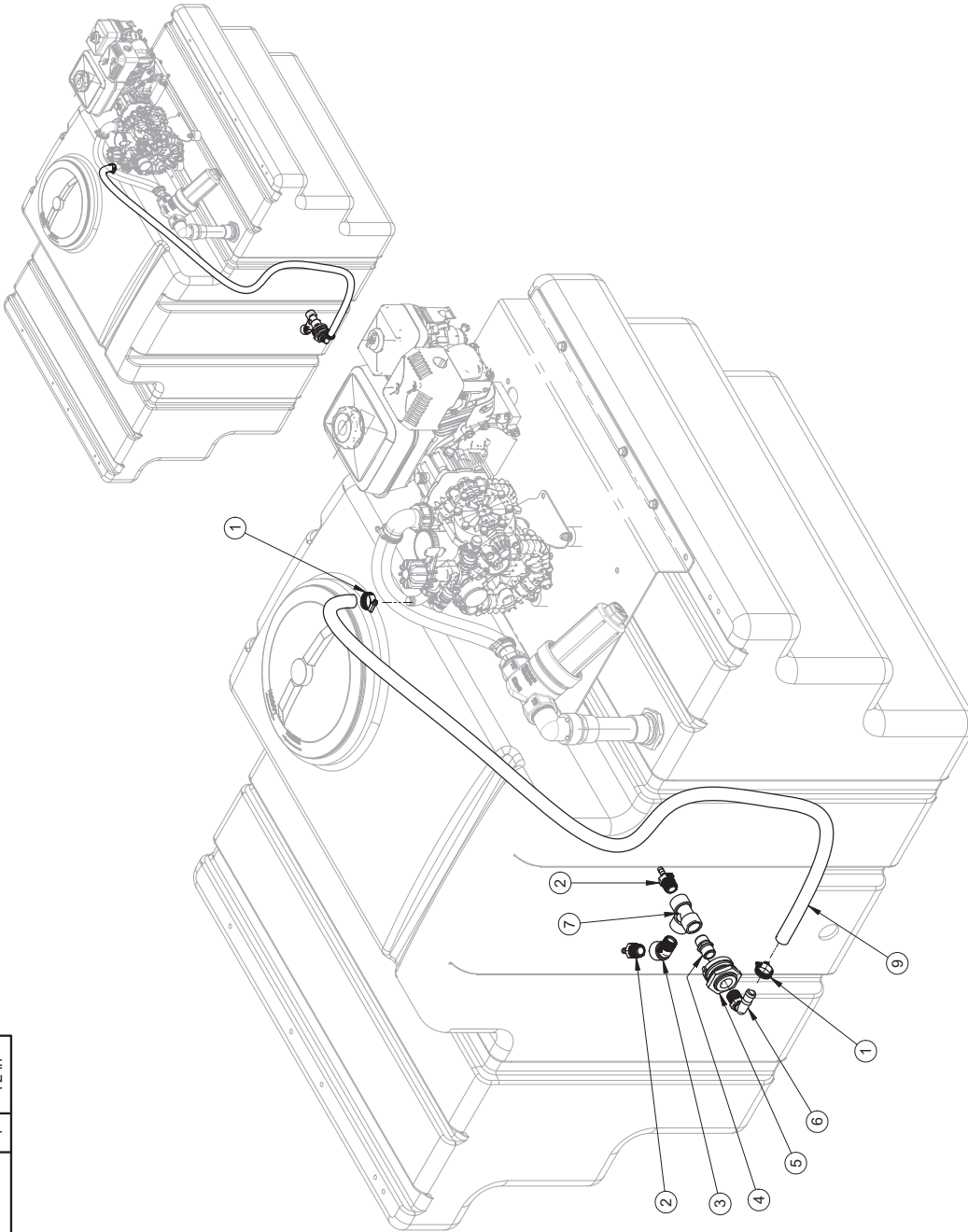

<p>Tous droits réservés. Toute réimpression, reproduction ou utilisation non autorisée sans la permission écrite de la société MS Gregson est formellement interdite.</p> <p>All rights reserved. Any reprinting, reproduction or unauthorized use without the written permission of MS Gregson is expressly prohibited.</p>		<p>AVIS: Information contenue dans ce document est la propriété exclusive de MS Gregson. Toute réimpression, reproduction ou utilisation non autorisée sans la permission écrite de la société MS Gregson est formellement interdite.</p> <p>NOTICE: Information contained in this document is the property of MS Gregson. Any reprinting, reproduction or unauthorized use without the written permission of MS Gregson is expressly prohibited.</p>	
<p>LES VALEURS SONT EN MILLIMETRES THE VALUES ARE IN INCHES TOLERANCES GENERALES GENERAL TOLERANCES Angles: ± 1° XX ± 0.1° XXX ± 0.05°</p>		<p>MS GREGSON M S G R E G S O N</p>	
<p>1 - LES VALEURS SONT EN MILLIMETRES 2 - THE VALUES ARE IN INCHES 3 - TOLERANCES GENERALES 4 - GENERAL TOLERANCES 5 - Angles: ± 1° 6 - XX ± 0.1° 7 - XXX ± 0.05°</p>		<p>MS GREGSON M S G R E G S O N</p>	
Rev 1	Change position de JB-TT34NY. Remplacer JB-IMB0303NY par JB-IMB0603NY	2020-05-12	trudéj
Rev	Description	Date	Approbation
<p>1 - FEUILLE / SHEET # 2 - CR370-0011</p>		<p>3 - CREATEUR / CREATOR 4 - trudéj</p>	
<p>5 - DESCRIPTION 6 - Ensemble d'agitation pour pompe membrane DP423 et D30 (série C)</p>		<p>7 - REVISION PAR / BY 8 - trudéj</p>	
<p>9 - DESSIN / DRAWING # 10 - CR370-0011</p>		<p>11 - DATE CREATION 12 - 2018-11-12</p>	
<p>13 - REVISION DATE 14 - 2020-05-12</p>		<p>15 - PAGE 16 - 1 of 2</p>	
<p>17 - ECHELLE / SCALE 18 - 1:25</p>		<p>19 - REVISION 20 - 1</p>	

SCHÉMA D'ASSEMBLAGE • DRAWING ASSEMBLY

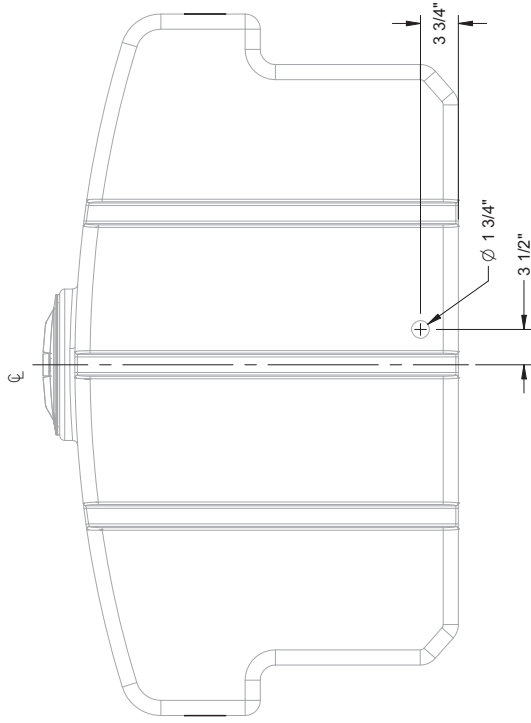

C400
PERÇAGE DU RÉSERVOIR

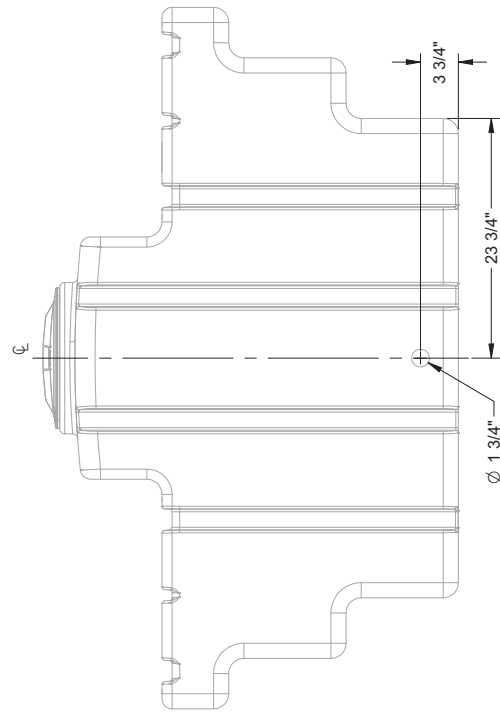

C300
PERÇAGE DU RÉSERVOIR

<p>AVIS: Information circulaire a été émise par M.S. GREGSON, qui se réserve tous droits réservés. Toute réimpression, reproduction, copie, utilisation, ou modification sans autorisation écrite de M.S. GREGSON est formellement interdite.</p> <p>NOTICE: Information disclosed herein is the property of M.S. GREGSON, who reserves all patent rights therein. Any reproduction or modification without written permission of M.S. GREGSON is strictly prohibited.</p>		<p># FEUILLE / SHEET # CR370-0011- PERÇAGE RÉSERVOIR</p>	<p>DATE CREATION 2018-11-12</p>	<p>CREATEUR / CREATOR trudelj</p>	<p>REVISION DATE 2020-05-12</p>	<p>PAGE 2 of 2</p>
<p>1- LES VALEURS SONT EN POUCES SAUF SPÉCIFIÉ AUTrement. UNLESS SPECIFIED OTHERWISE, DIMENSIONS ARE IN INCHES. 2- GÉNÉRALISER LES ÉCHANGES FIG. 1 1/16" X.XX ± 0.01" X.X ± 0.1" X.XXX ± 0.005"</p>		<p>DESCRIPTION Ensemble d'agitation pour pompe membrane DP423 et D30 (série C)</p>		<p>REVISION PAR / BY trudelj</p>	<p>REVISION DATE 2020-05-12</p>	<p>REVISION 1</p>
<p>Revisi Description</p>		<p>Revisi Description</p>		<p>Revisi Description</p>		<p>Revisi Description</p>
<p>Revisi Description</p>		<p>Revisi Description</p>		<p>Revisi Description</p>		<p>Revisi Description</p>

SCHÉMA D'ASSEMBLAGE • DRAWING ASSEMBLY

#	REF.	Q.	L"
8	LV-342N	1	72 in

#	REF.	Q.
1	DA-SHAS12	2
2	JB-IMB0603NY	2
3	BJ-SL07545	2
4	JB-M3400NY	1
5	RA-5032P	1
6	JB-EL3434NY	1
7	JB-TT34NY	1

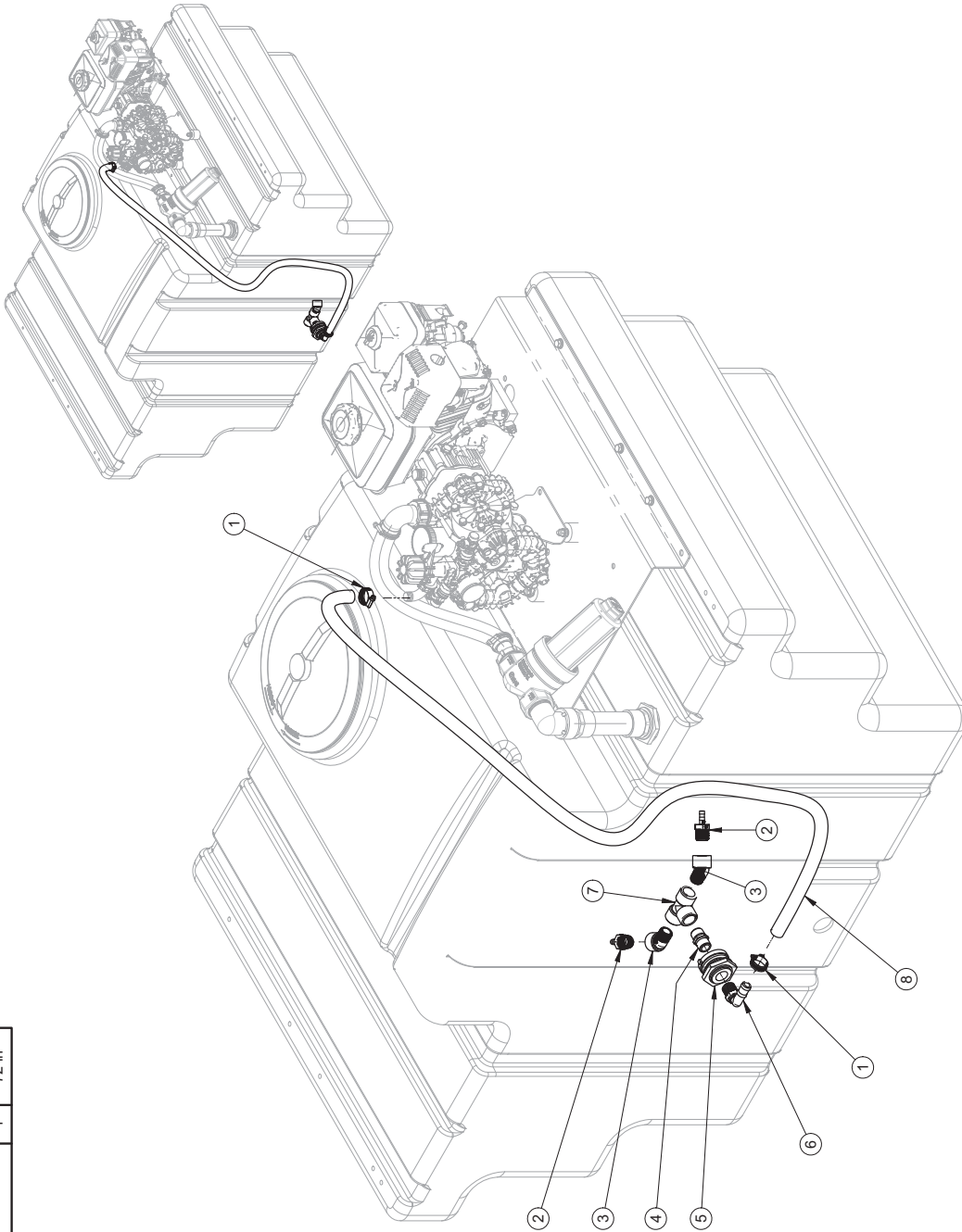

#	REF.	Q.	L"
8	LV-342N	1	72 in

#	REF.	Q.
1	DA-SHAS12	2
2	JB-IMB0603NY	2
3	BJ-SL07545	2
4	JB-M3400NY	1
5	RA-5032P	1
6	JB-EL3434NY	1
7	JB-TT34NY	1

#	FEUILLE / SHEET #	DATE CREATION	CREATEUR / CREATOR	REVISION DATE	PAGE
1	CR370-0026	2020-06-11	trudej	2020-06-11	1 of 2

DESCRIPTION	REVISION PAR / BY	REVISION
Ensemble d'agitation pour pompe DP423 et D30 (C200-C300)	trudej	0

REVISION	DESCRIPTION	DATE	Approbation
Rev 1	Changer position de JB-TT34NY. Remplacer JB-IMB0303NY par JB-IMB0603NY	2020-05-12	trudej
Rev	Description		

1- LES VALEURS SONT EN	1- ALL INFORMATION CONTAINED HEREIN
UNITS / LES VALEURS SONT EN UNITS	IS FOR THE PROPRIETOR'S USE ONLY AND IS NOT TO BE REPRODUCED OR TRANSMITTED IN ANY FORM OR BY ANY MEANS, ELECTRONIC OR MECHANICAL, INCLUDING PHOTOCOPYING, RECORDING, OR BY ANY INFORMATION STORAGE AND RETRIEVAL SYSTEM, WITHOUT THE WRITTEN PERMISSION OF THE PROPRIETOR.
GENERAL TOLERANCES	UNLESS OTHERWISE SPECIFIED
XXX ± 0.1"	
XX ± 0.01"	
XX ± 0.005"	
XXXX ± 0.005"	

MSG	M S G R E G G S O N
DESIGN / DRAWING # CR370-0026	

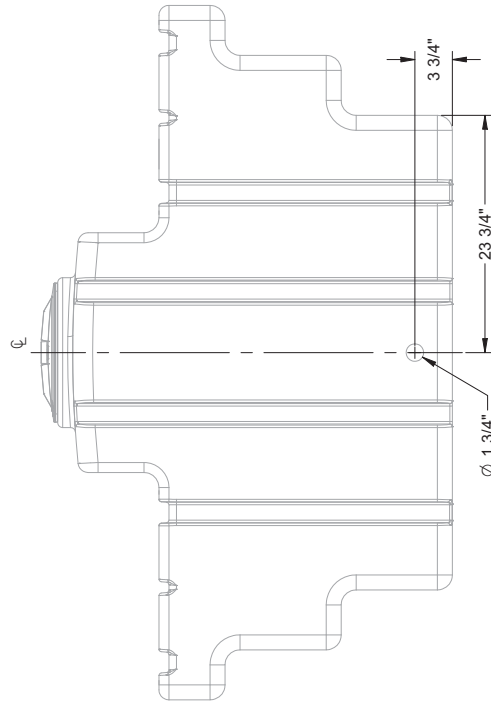

C200 - C300
PERÇAGE DU RÉSERVOIR

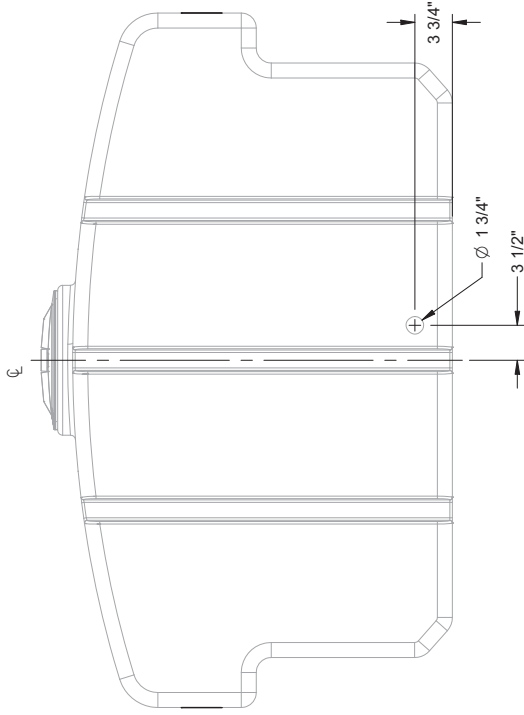

C400
PERÇAGE DU RÉSERVOIR

<p>1- LES VALEURS SONT EN POUCE 2- VALUÉS EN INCHES 3- UNITS IN INCHES 4- GENERAL TOLERANCES A: ± 0.1" B: ± 0.15" C: ± 0.1" D: ± 0.05" E: ± 0.05" F: ± 0.05" G: ± 0.05" H: ± 0.05" I: ± 0.05" J: ± 0.05" K: ± 0.05" L: ± 0.05" M: ± 0.05" N: ± 0.05" O: ± 0.05" P: ± 0.05" Q: ± 0.05" R: ± 0.05" S: ± 0.05" T: ± 0.05" U: ± 0.05" V: ± 0.05" W: ± 0.05" X: ± 0.05" Y: ± 0.05" Z: ± 0.05"</p>		<p>ANS Information on sheets is the property of the manufacturer and is not to be reproduced, stored, transmitted, or disseminated in any form or by any means, including electronic, mechanical, photocopying, recording, or by any information storage and retrieval system, without the prior written permission of the manufacturer.</p>		<p>MSG M S G R E G S O N</p>		<p># FEUILLE / SHEET # CR370-0026- PERÇAGE RÉSERVOIR</p>		<p>DATE CREATION 2020-06-11</p>		<p>CREATEUR / CREATOR trudelj</p>		<p>REVISION DATE 2020-06-11</p>		<p>PAGE 2 of 2</p>	
<p>DESCRIPTION Ensemble d'agitation pour pompe DP423 et D30 (C200-C300)</p>		<p>REVISION PAR / BY trudelj</p>		<p>REVISION DATE 2020-06-11</p>		<p>REVISION SCALE 1:1</p>		<p>REVISION 0</p>		<p>REVISION 0</p>		<p>REVISION 0</p>		<p>REVISION 0</p>	
<p>Reviser / Reviser Description</p>		<p>Reviser / Reviser Date</p>		<p>Reviser / Reviser Date</p>		<p>Reviser / Reviser Date</p>		<p>Reviser / Reviser Date</p>		<p>Reviser / Reviser Date</p>		<p>Reviser / Reviser Date</p>		<p>Reviser / Reviser Date</p>	

SCHÉMA D'ASSEMBLAGE • DRAWING ASSEMBLY

#	REF.	Q.
1	DA-SHAS12	2
2	RA-5034P	1
3	JB-EL1034NY	1
4	DA-CPVC1CM	2
5	JB-IMB0403NY	2
6	JB-RB10012NY40	2
7	JB-TT100NY	1

#	REF.	Q.	L"
8	LV-342N	1	36 in
9	AU-TU1P	1	36 in

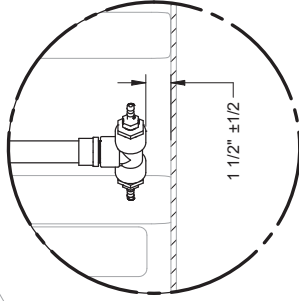
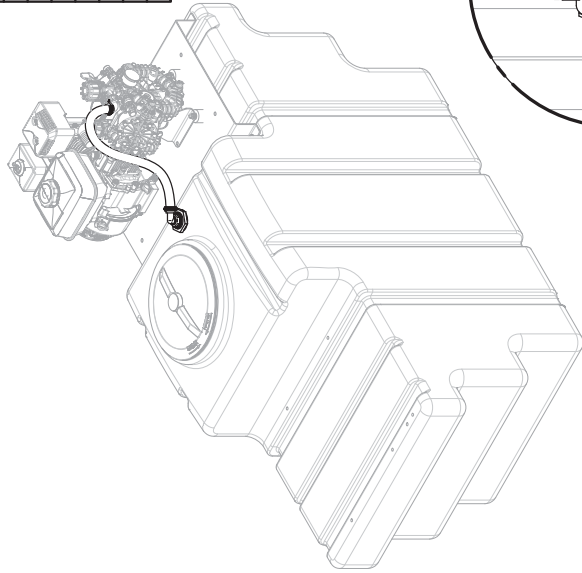
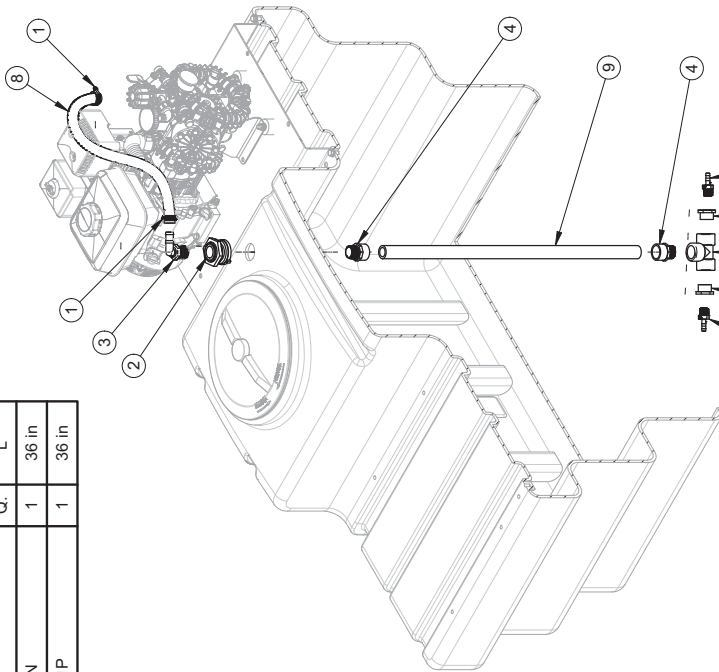

DETAIL A

AJUSTER LA LONGUEUR POUR OBTENIR 1 1/2" DE DÉGAGEMENT AVEC LE FOND DU RÉSERVOIR

MODÈLE	LONGUEUR APPROXIMATIVE
C200	31"
C300	
C400	

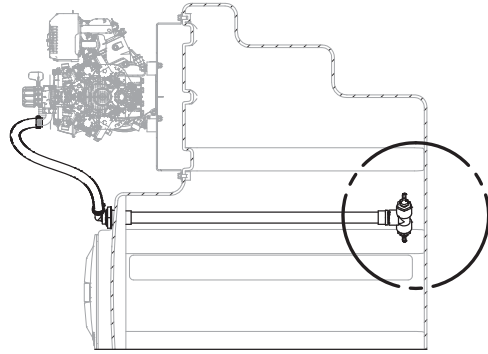

ORIENTATION DU "COUDE"

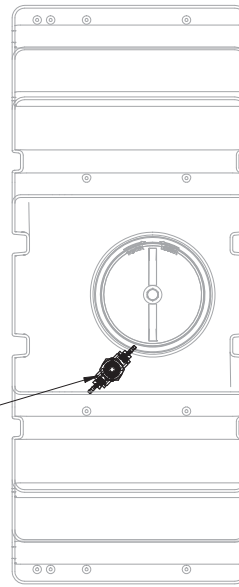

<p>1- LES VALEURS SONT EN INCHES 2- LES VALEURS SONT EN MILLIMÈTRES 3- LES VALEURS SONT EN CENTIMÈTRES 4- LES VALEURS SONT EN POUCE</p>		<p># FEUILLE / SHEET # CR370-0027</p>		<p>DATE CREATION 2020-06-12</p>		<p>CREATEUR / CREATOR trudej</p>		<p>REVISION / REVISION trudej</p>		<p>REVISION / REVISION 1 of 2</p>	
<p>MSG M S G R E G G O N</p>		<p>DESCRIPTION Ensemble d'agitation pour pompe membrane DP423 et D30 - série C</p>		<p>#DESSIN / DRAWING # CR370-0027</p>		<p>ECHELLE / SCALE 1:16.67</p>		<p>REVISION / REVISION 0</p>		<p>PAGE 1 of 2</p>	
<p>1- LES VALEURS SONT EN INCHES 2- LES VALEURS SONT EN MILLIMÈTRES 3- LES VALEURS SONT EN CENTIMÈTRES 4- LES VALEURS SONT EN POUCE</p>		<p>MSG M S G R E G G O N</p>		<p>DESCRIPTION Ensemble d'agitation pour pompe membrane DP423 et D30 - série C</p>		<p>#DESSIN / DRAWING # CR370-0027</p>		<p>ECHELLE / SCALE 1:16.67</p>		<p>REVISION / REVISION 0</p>	
Rev	Description	Date	Approbation								

SCHÉMA D'ASSEMBLAGE • DRAWING ASSEMBLY

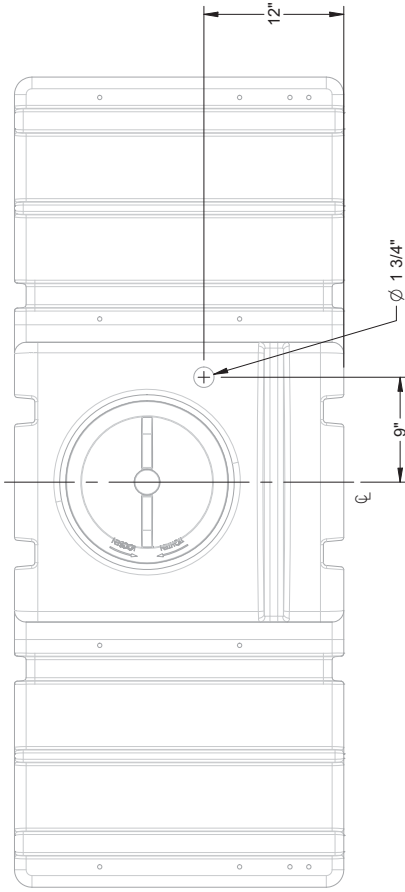

C200
PERÇAGE DU RÉSERVOIR

Rev.	Description	Date	Approbation

<p>1. LES VALEURS SONT EN POUCE SAUF SPÉCIFIÉ</p> <p>2. TOLERANCES GÉNÉRALES</p> <p>Angles: ± 1°</p> <p>XXX ± 0.01"</p> <p>XXXX ± 0.05"</p>	<p>AVIS: Informations d'origine à l'usage interne uniquement pour les besoins de la production.</p> <p>NOTICE: Information disclosed herein is the property of M.S.G. and is not to be reproduced, stored, or transmitted in any form or by any means, electronic, mechanical, photocopying, recording, or by any information storage and retrieval system, without the prior written permission of M.S.G.</p>	<p># FEUILLE / SHEET #</p> <p>CR370-0027-PERÇAGE DU RÉSERVOIR</p>	<p>DATE CREATION</p> <p>2020-06-12</p>	<p>CRÉATEUR / CREATOR</p> <p>trudelj</p>	<p>REVISION DATE</p> <p>2020-06-12</p>	<p>PAGE</p> <p>2 of 2</p>
<p>DESCRIPTION</p> <p>Ensemble d'agitation pour pompe membrane DP423 et D30 - série C</p>	<p>REVISION PAR / BY</p> <p>trudelj</p>	<p>REVISION DATE</p> <p>2020-06-12</p>	<p>REVISION PAR / BY</p> <p>trudelj</p>	<p>REVISION DATE</p> <p>2020-06-12</p>	<p>REVISION</p> <p>0</p>	<p>ECHELLE / SCALE</p> <p>1:10</p>
<p># DRESSIN / DRAWING #</p> <p>CR370-0027</p>	<p>REVISION</p> <p>0</p>	<p>REVISION DATE</p> <p>2020-06-12</p>	<p>REVISION PAR / BY</p> <p>trudelj</p>	<p>REVISION DATE</p> <p>2020-06-12</p>	<p>REVISION</p> <p>0</p>	<p>ECHELLE / SCALE</p> <p>1:10</p>

SCHEMA D'ASSEMBLAGE • DRAWING ASSEMBLY

#	REF.	Q.
1	DA-SHAS16	2
2	JB-IMB0808NY	1
3	MP-3244043	1
4	BJ-RN150100	1
5	JB-LL112NY	1
6	DA-CPVC112CM	3
7	RA-5039P	1

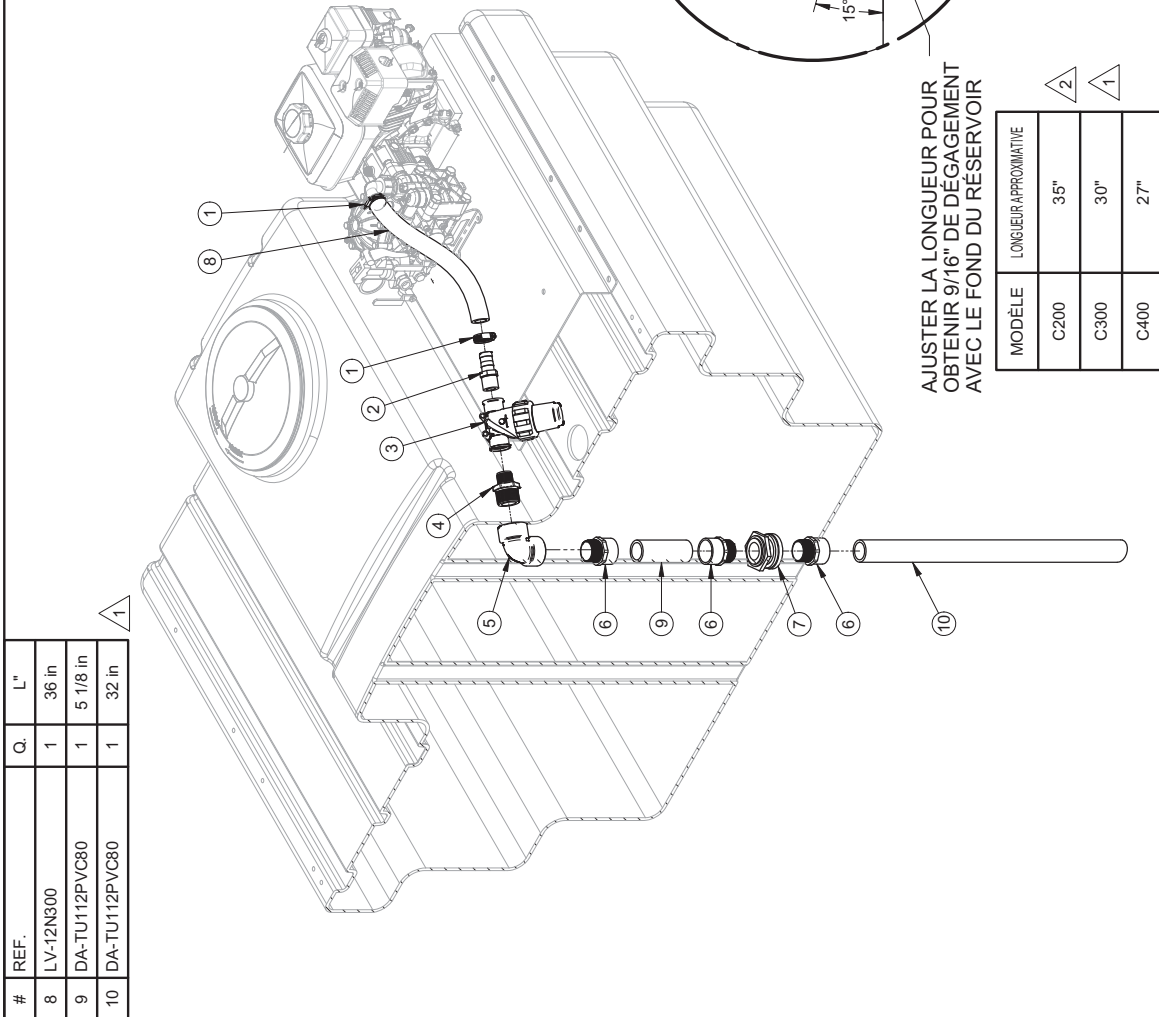
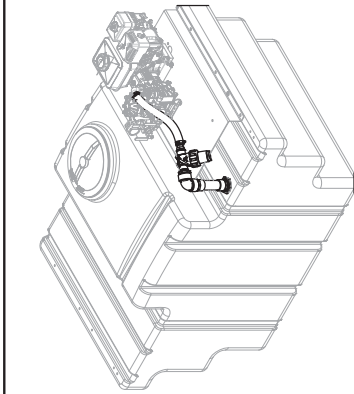

AJUSTER LA LONGUEUR POUR
OBTENIR 9/16" DE DÉGAGEMENT
AVEC LE FOND DU RÉSERVOIR

MODÈLE	LONGUEUR APPROXIMATIVE
C200	35"
C300	30"
C400	27"

#	REF.	Q.
8	LV-12N300	1
9	DA-TU112PVC80	1
10	DA-TU112PVC80	1

# FEUILLE / SHEET #	DATE CREATION	CREATEUR / CREATOR	REVISION DATE	PAGE
CR370-0014	2020-02-19	trudelj	2020-06-15	1 of 2
DESCRIPTION		REVISION PAR / BY	REVISION	
Ensemble d'aspiration 1 1/2" - 1" pour pompe D30 (série C)		trudelj	2	
#DESSIN / DRAWING #		ECHELLE / SCALE		REVISION
CR370-0014		1:33.33		2

REV	Description	Date	Approbation
2	Regular passage pour le réservoir C200	2020-06-15	trudelj
1	Modifier position de la ligne d'aspiration pour le C400 (sur le côté au lieu du centre)	2020-03-15	trudelj

MSG M S G R E G G S O N
 LES VALEURS SONT EN INCHES
 GENERAL TOLERANCES
 X.X ± 0.1"
 X.XX ± 0.05"
 X.XXX ± 0.005"
 (Tous les autres tolérances sont à la discrétion de l'utilisateur)

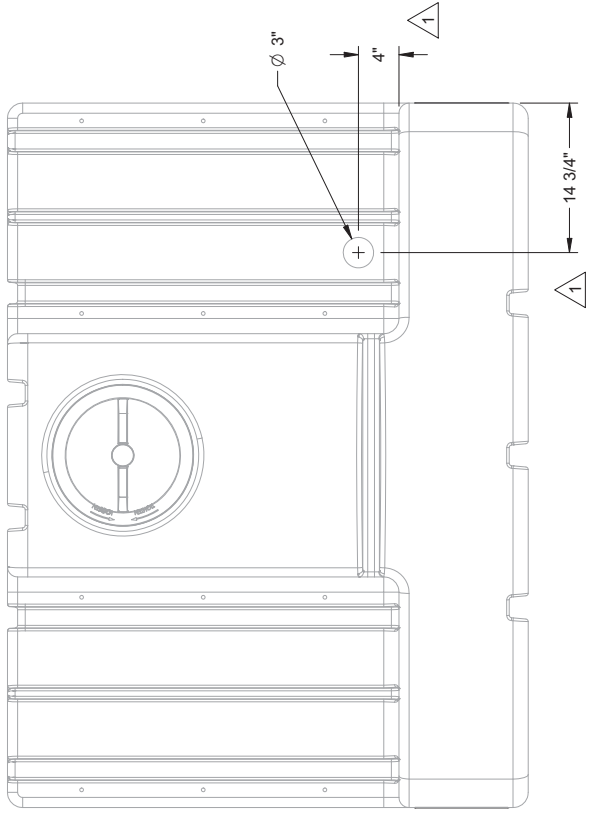

**C400
PERÇAGE DU RÉSERVOIR**

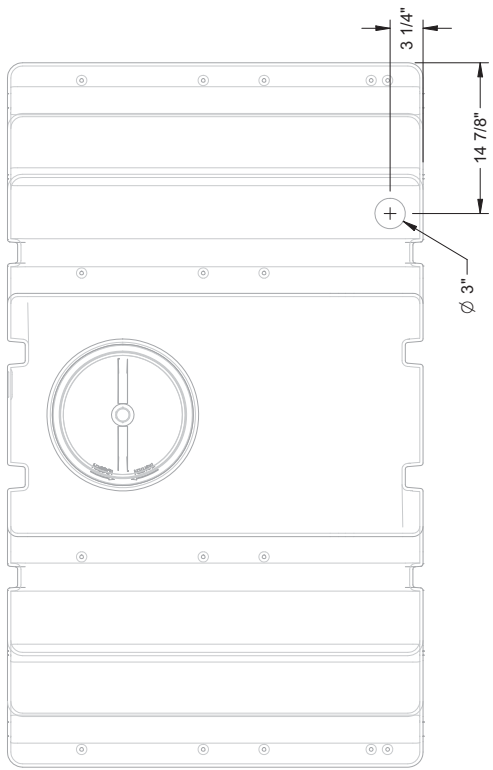

**C300
PERÇAGE DU RÉSERVOIR**

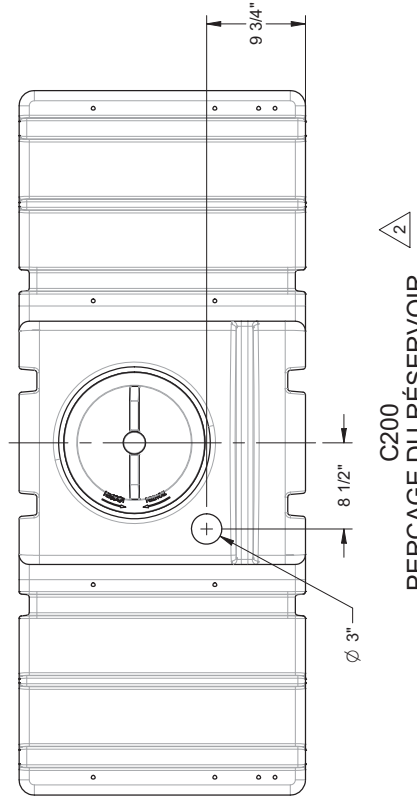

**C200
PERÇAGE DU RÉSERVOIR**

# FEUILLE / SHEET #	DATE CREATION	CRÉATEUR / CREATOR	REVISION DATE	PAGE
CR370-0014- PERÇAGE RÉSERVOIR	2020-02-19	trudej	2020-06-15	2 of 2
DESCRIPTION			trudej	REVISION
Ensemble d'aspiration 1 1/2" - 1" pour pompe D30 (série C)			trudell	REVISION
#DESSIN / DRAWING #			trudell	REVISION
CR370-0014			1:10	2

1- LES VALEURS SONT EN POINÇON SAUF SI SPÉCIFIÉ	2- TOLÉRANCES GÉNÉRALES
UNLESS SPECIFIED	ANGLES: 1:1
UNLESS SPECIFIED	FRACTION: 1/16"
	DECIMAL: 0.005"
	XXX: ± 0.01"
	XXXX: ± 0.005"

Rev	Description	Date	Approbation
2	Rejoindre perçage pour le réservoir C200	2020-06-15 trudej	
1	Modifier position de la ligne d'aspiration pour le C200 (sur le côté au lieu du centre)	2020-03-17 trudej	

ANSI	Information	Information
1	Information contained herein is the property of M.S. GREGGON, Inc. and shall remain confidential. No part of this document may be reproduced, stored in a retrieval system, or transmitted in any form or by any means, electronic, mechanical, photocopying, recording, or otherwise, without the prior written permission of M.S. GREGGON, Inc.	
NOTE	Information disclosed herein is the property of M.S. GREGGON, Inc. and shall remain confidential. No part of this document may be reproduced, stored in a retrieval system, or transmitted in any form or by any means, electronic, mechanical, photocopying, recording, or otherwise, without the prior written permission of M.S. GREGGON, Inc.	

SCHEMA D'ASSEMBLAGE • DRAWING ASSEMBLY

#	REF.	Q.
1	DA-WASHER	1
2	JB-SGM0004BR	1
3	MP-S301200PP	1
4	JB-RMM0406NY	1
5	JB-12234PP50	1
6	JB-SE34NY	1
7	JB-M3400NY	1
8	RA-5032P	1
9	BJ-NIP0756	1
10	JB-552703418POM	1

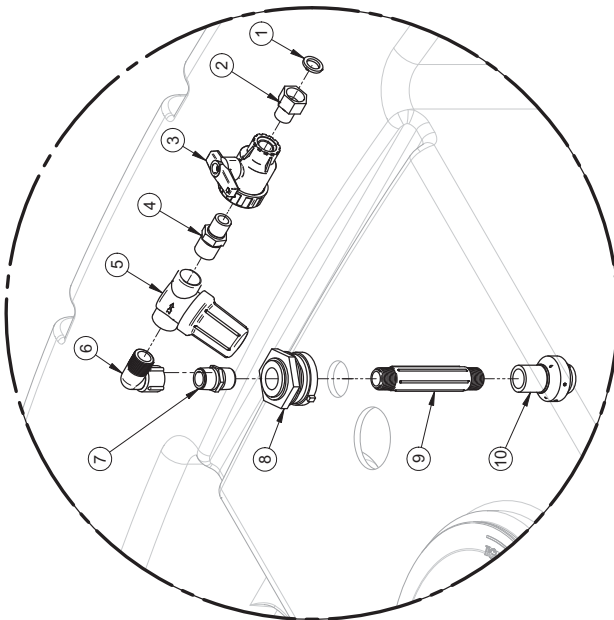
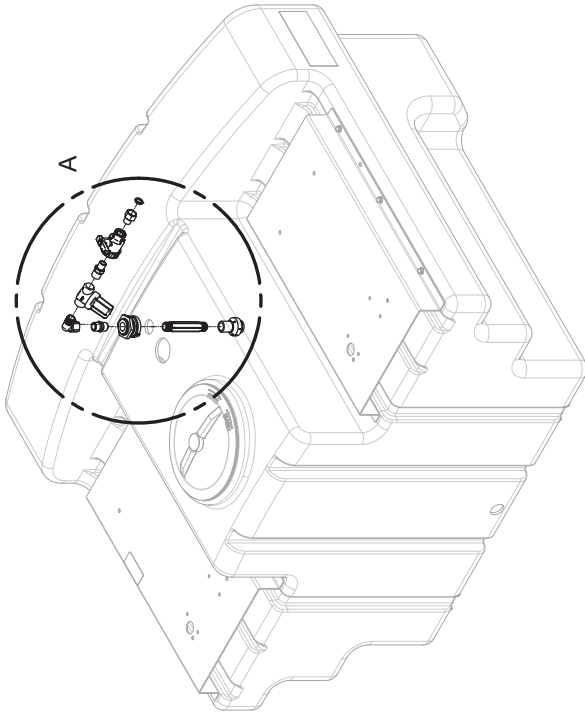

DETAIL A
1:8

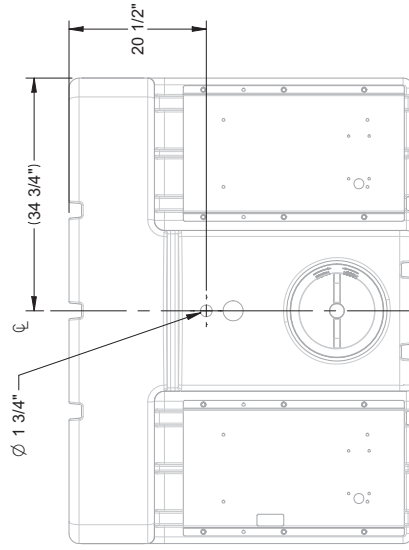

C400
PERÇAGE DU RÉSERVOIR

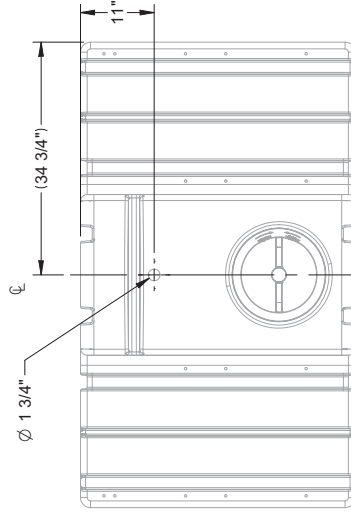

C300
PERÇAGE DU RÉSERVOIR

Rev	Description	Date	Approbation

1- LES VALEURS SONT EN MILLIMÈTRES SAUF INDICATION CONTRAIRE UNLESS SPECIFIED IN INCHES, ALL DIMENSIONS ARE IN MILLIMETERS UNLESS OTHERWISE SPECIFIED	MSG M S G R E G G S O N	# FEUILLE / SHEET # CR370-0018	DATE CREATION 2020-02-27	CRÉATEUR / CREATOR trudelji	REVISION DATE 2020-02-28	PAGE 1 of 1
2- GENERAL TOLERANCES XX ± 0.1" XXX ± 0.005"		DESCRIPTION Jet rinçeur pour réservoir avec adaptateur boyau à jardin et valve à bille			REVISION PAR / BY trudelji	ECHELLE / SCALE 1:20
		#DESSIN / DRAWING # CR370-0018				REVISION 0

SCHEMA D'ASSEMBLAGE • DRAWING ASSEMBLY

#	REF.	Q.	L"
9	LV-122N	1	72 in

#	REF.	Q.
1	BJ-RN200150	1
2	JB-B112PG	1
3	JB-TT112NY	1
4	JB-RB11234NY	1
5	JB-EL3412NY	2
6	DA-SHAS6	2
7	RA-5032P	1
8	JB-IMB0604NY	1

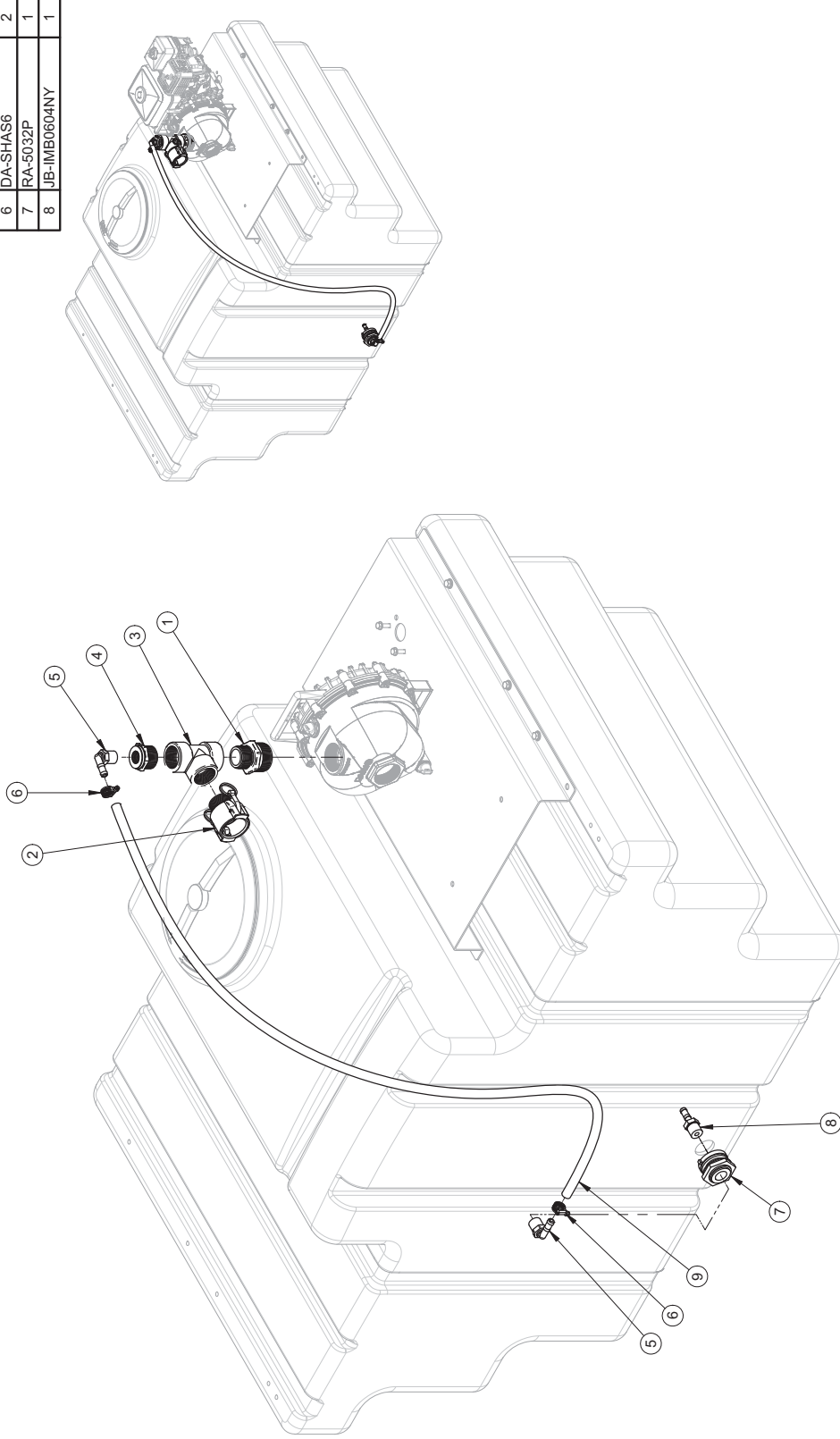

#	REF.	Q.	L"
9	LV-122N	1	72 in

#	REF.	Q.
1	BJ-RN200150	1
2	JB-B112PG	1
3	JB-TT112NY	1
4	JB-RB11234NY	1
5	JB-EL3412NY	2
6	DA-SHAS6	2
7	RA-5032P	1
8	JB-IMB0604NY	1

1- LES VALEURS SONT EN POUCES	UNLESS SPECIFIED IN INCHES
2- GENERAL TOLERANCES	Fr. : ± 0.10"
	X, X.1, 0.1"
	X, XXX ± 0.005"

MSG	M S G R E G S O N
<p>1- LES VALEURS SONT EN POUCES</p> <p>UNLESS SPECIFIED IN INCHES</p> <p>2- GENERAL TOLERANCES</p> <p>Fr. : ± 0.10"</p> <p>X, X.1, 0.1"</p> <p>X, XXX ± 0.005"</p>	
<p>MSG (MAGNETIC SYSTEMS GROUP) est une marque déposée de M.S. GREGGON, qui se réserve tous droits de propriété intellectuelle pour la conception, vente, utilisation, réparation, vente, utilisation. Toute réimpression ou utilisation non autorisée sans la permission écrite de la M.S. GREGGON est formellement interdite. Toute réimpression ou utilisation non autorisée sans la permission écrite de la M.S. GREGGON, who reserves all patent rights in this drawing, is hereby prohibited.</p>	
# FEUILLE / SHEET #	CR370-0019
DESCRIPTION	Plomberie sortie de pompe centrifuge pour la série C
#DESSIN / DRAWING #	CR370-0019
DATE CREATION	2020-03-12
CREATEUR / CREATOR	trudej
REVISION PAR / BY	trudej
REVISION DATE	2020-04-30
ECHELLE / SCALE	1:12.5
PAGE	1 of 2
REVISION	1

Rev.	Description	Date	Approbation
Rev. 1	Changer position de JB-TT112NY	2020-04-30	trudej
Rev.	Reception		

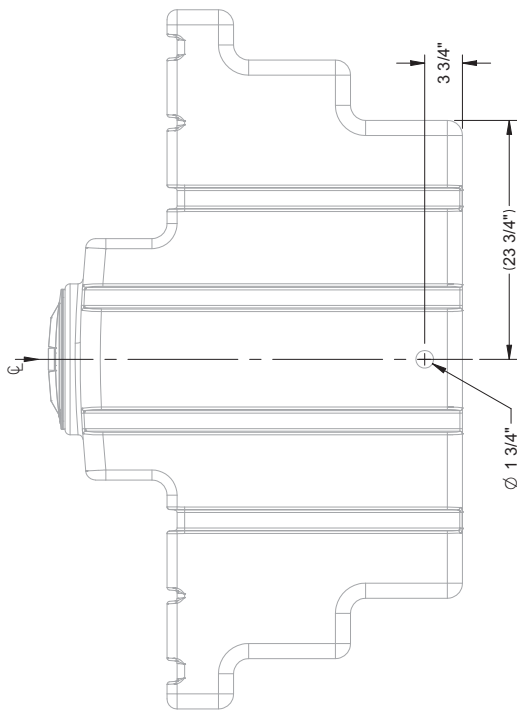

C300
PERÇAGE DU RÉSERVOIR

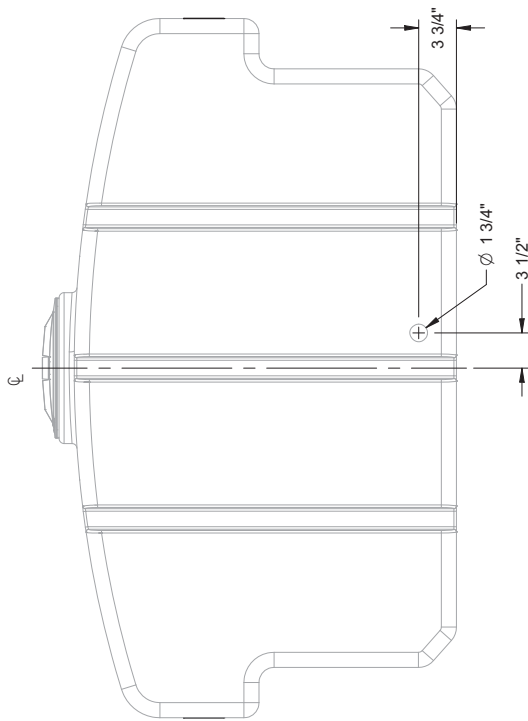

C400
PERÇAGE DU RÉSERVOIR

<p>1- LES VALEURS SONT EN POUCES / LES VALEURS SONT EN INCHES UNLESS SPECIFIED IN FEET / UNLESS SPECIFIED IN INCHES 2- GENERAL TOLERANCES Frac.: ± 1/16" XX ± 0.01" X ± 0.1" XXX ± 0.05"</p>		<p>MSG M S G R E G O N</p>		<p>NOTES: 1- LES VALEURS SONT EN POUCES / LES VALEURS SONT EN INCHES UNLESS SPECIFIED IN FEET / UNLESS SPECIFIED IN INCHES 2- GENERAL TOLERANCES Frac.: ± 1/16" XX ± 0.01" X ± 0.1" XXX ± 0.05"</p>		<p># FEUILLE / SHEET # CR370-0019- PERÇAGE RÉSERVOIR</p>		<p>DATE CREATION 2020-03-12</p>		<p>CREATEUR / CREATOR trudelj</p>		<p>REVISION DATE 2020-04-30</p>		<p>PAGE 2 of 2</p>	
<p>DESCRIPTION Plomberie sortie de pompe centrifuge pour la série C</p>		<p># DESSIN / DRAWING # CR370-0019</p>		<p>REVISION PAR / BY trudelj</p>		<p>ECHELLE / SCALE 1:1.16.67</p>		<p>REVISION 1</p>		<p>Rev. 1 Description</p>		<p>Rev. 1 Description</p>		<p>Rev. 1 Description</p>	

SCHÉMA D'ASSEMBLAGE • DRAWING ASSEMBLY

#	REF.	Q.
1	BJ-M200MPT	1
2	BJ-150G	1
3	BJ-FC200	1
4	BJ-M200150BRB	1
5	DA-SHAS24	2
6	JB-IMB1212NY	1
7	JB-LL112NY	1
8	DA-CPVC112CM	3
9	RA-5039P	1

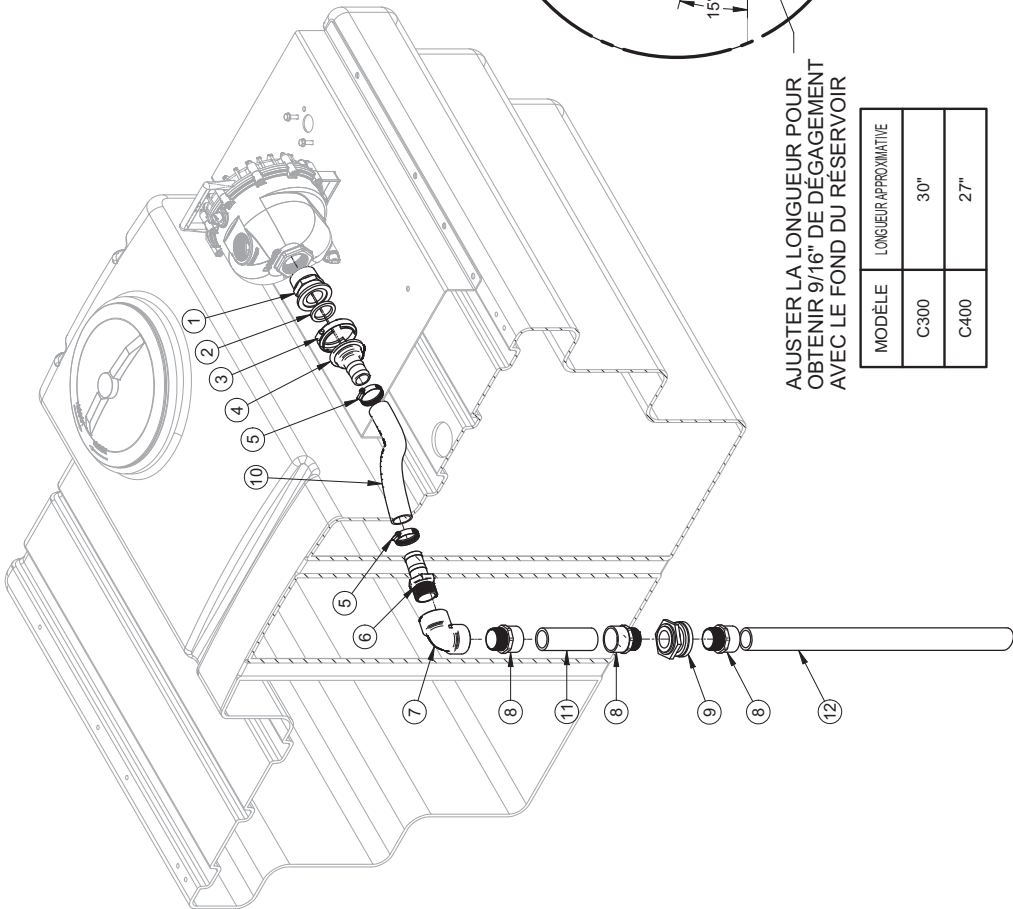
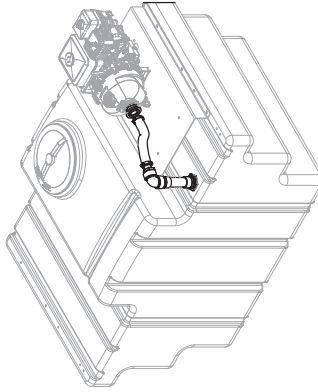

AJUSTER LA LONGUEUR POUR OBTENIR 9/16" DE DÉGAGEMENT AVEC LE FOND DU RÉSERVOIR

MODÈLE	LONGUEUR APPROXIMATIVE
C300	30"
C400	27"

DETAIL A
1:5.33

#	REF.	Q.	L"
10	LV-112PVC	1	12 in
11	DA-TU112PVC80	1	5 1/8 in
12	DA-TU112PVC80	1	32 in

# FEUILLE / SHEET #	CREATEUR / CREATOR	REVISION DATE	PAGE
CR370-0020	trudej	2020-04-30	1 of 2
DESCRIPTION	REVISION PAR / BY	REVISION	REVISION
Ensemble d'aspiration 1 1/2" pour pompe centrifuge (série C)	trudej		
# DESSIN / DRAWING #	ECHELLE / SCALE	REVISION	REVISION
CR370-0020	1:33.33		1

MSG
M S G R E G G S O N

1- LES VALEURS SONT EN POUCE SAUF SI SPÉCIFIÉ
2- TOLEFRANSES GENERALES
X-XX: ± 0.1"
X-XX: ± 0.01"
X-XXX: ± 0.005"

AVIS: Information conclusive at 80% communication, fabrication et/ou livraison. MS GREGGON, qui se réserve tous droits réservés.
NOTICE: Information disclosed herein preliminary, design, and subject to change without notification. MS GREGGON, who reserves all rights herein.

Rev	Description	Date	Approbation
Rev1	Ensemble d'aspiration 1 1/2" pour pompe centrifuge (série C)	2020-04-30	trudej

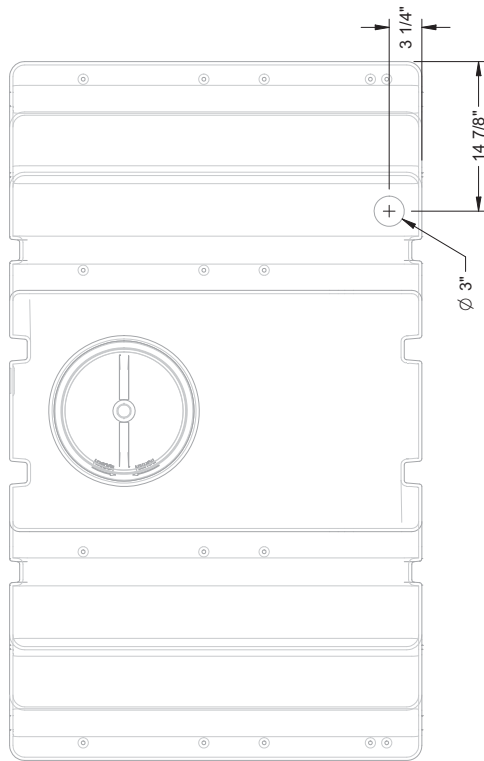

C300
PERÇAGE DU RÉSERVOIR

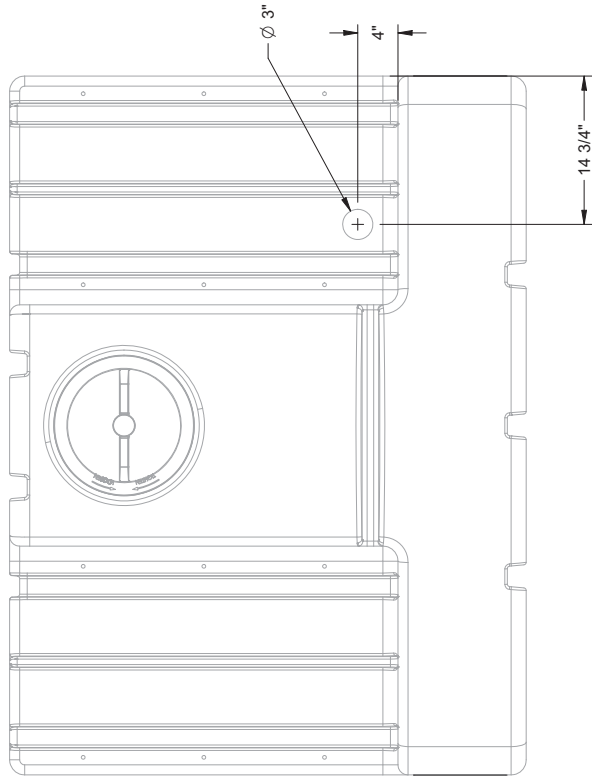

C400
PERÇAGE DU RÉSERVOIR

Rev	Description	Date	Approbation
Rev 1	Enlever JB-BT12FG, JB-E112FG et JB-IMB1612NY.	2020-04-30	trudelj
Rev 2		2020-04-30	trudelj

# FEUILLE / SHEET #	DATE CREATION	CRÉATEUR / CREATOR	REVISION DATE	PAGE
CR370-0020- PERÇAGE RÉSERVOIR	2020-03-12	trudelj	2020-04-30	2 of 2
DESCRIPTION		REVISION PAR / BY		
Ensemble d'aspiration 1 1/2" pour pompe centrifuge (série C)		trudelj		
#DESSIN / DRAWING #		ECHELLE / SCALE		
CR370-0020		1:10		
REVISION		REVISION		
1		1		

1- LES VALEURS SONT EN POULCES À MOINS QUE NOTÉ	1- UNLESS SPECIFIED, DIMENSIONS ARE IN INCHES
2- GENERAL TOLERANCES	2- GENERAL TOLERANCES
Frac.: ± 1/16"	Frac.: ± 1/16"
Dec.: ± 0.01"	Dec.: ± 0.01"
X.XX: ± 0.1"	X.XX: ± 0.1"
X.XXX: ± 0.005"	X.XXX: ± 0.005"

<p>AVIS DE PROPRIÉTÉ INTELLECTUELLE</p> <p>MS GREGSON, qui se réserve tous droits réservés en matière de conception, vente, utilisation, copie de reproduction.</p> <p>NOTICE INFORMATION</p> <p>MS GREGSON, who reserves all patent rights, trademark and/or reproduction rights.</p>	
--	--

SCHÉMA D'ASSEMBLAGE • DRAWING ASSEMBLY

REF	No	Q
1	RA-5042P	2
2	BLV/C230	1
3	MP-504019	1
4	JB-M2000NY	1
5	JB-SE200NY	1
6	NO-6228B	1
7	JB-DC2PG	1
8	BLV/20207	1

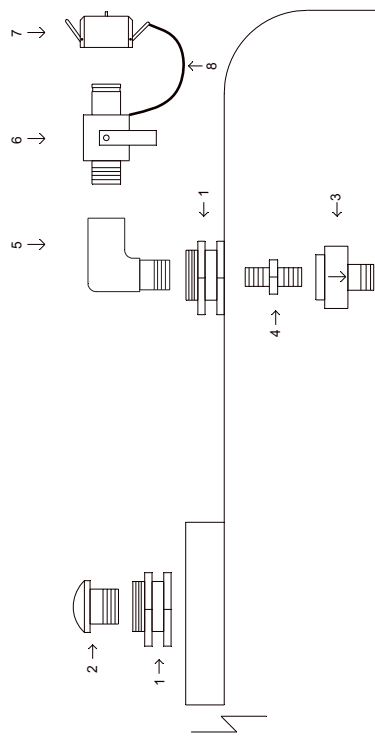
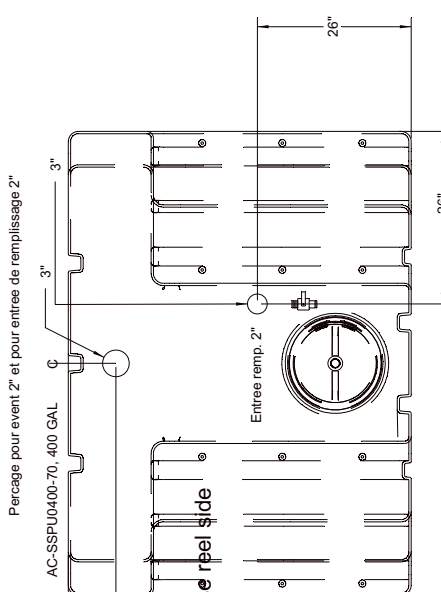
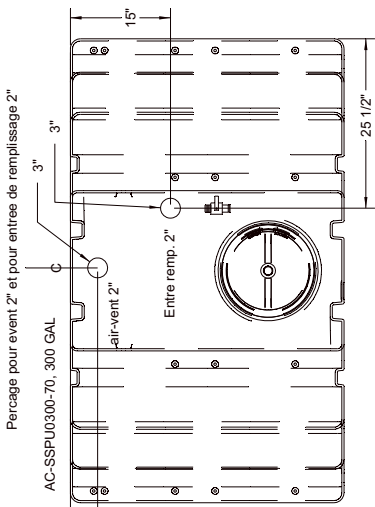

arriere unite

Vue dessus

AVIS: L'information contenue dans ce document est réservée à l'usage interne de nos clients. Toute réimpression ou utilisation non autorisée sans la permission écrite de la société est formellement interdite. Toute réimpression ou utilisation non autorisée sans la permission écrite de la société est formellement interdite. Toute réimpression ou utilisation non autorisée sans la permission écrite de la société est formellement interdite.

LES VALEURS SONT EN UNITS IMPÉRIALES UNLESS SPECIFIED OTHERWISE. DIMENSIONS ARE IN INCHES UNLESS OTHERWISE SPECIFIED. DIMENSIONS ARE IN INCHES UNLESS OTHERWISE SPECIFIED.

DATE CREATION: 2020-03-17
 CREATEUR / CREATOR: R.D.
 REVISION DATE: 2020-10-19
 REVISION PAR / BY: R.D.

FEUILLE / SHEET # CR370-0021
 # DESSIN / DRAWING # CR370-0021

Rev	Description	Date	Approbation

# FEUILLE / SHEET #	DATE CREATION	CREATEUR / CREATOR	REVISION DATE	PAGE
CR370-0021	2020-03-17	R.D.	2020-10-19	1 / 1
DESCRIPTION : 2" quick-fill kit - check-valve - breather			REVISION	REVISION
# DESSIN / DRAWING # CR370-0021			ECHELLE / SCALE	1

SCHEMA D'ASSEMBLAGE • DRAWING ASSEMBLY

#	REF.	Q.	L"
9	LV-122J	1	120"

#	REF.	Q.
1	AS-1921	3
2	JB-IMB0404BR	2
3	BT-381	4
4	BT-FW38	4
5	BT-LW38	4
6	BT-N38	4
7	HR-15261718E	1
8	LV-122J300	1
9	LV-122J	1



NE PAS UTILISER LA BOULONNERIE
POUR LES MODELES C200, C300 ET C400

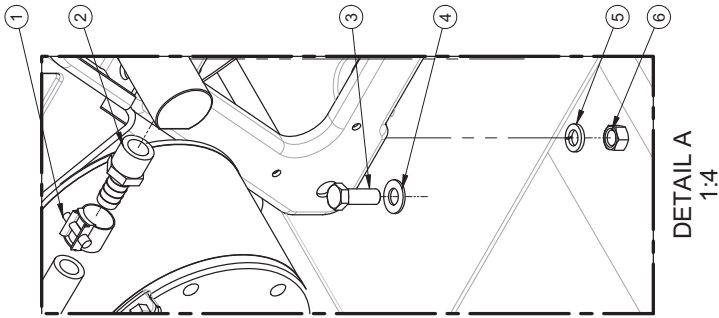
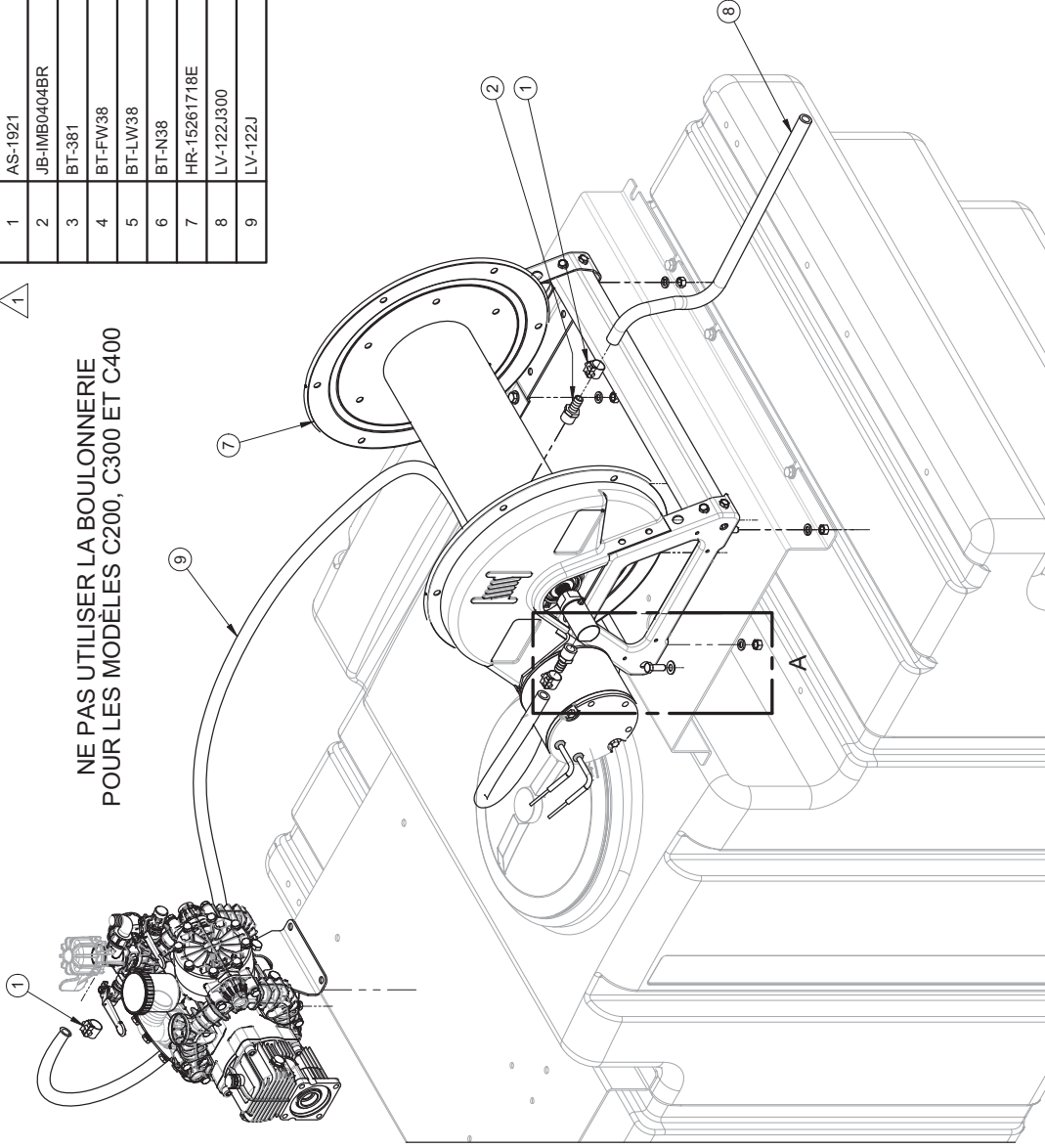

REF.	DESCRIPTION	DATE	CREATEUR	REVISION	DATE	REVISION	PAGE
Rev 1	LV-122J300 élett LV-122J AS-1921 élett DA-HSE	2020-02-27 (modif)			2020-08-31		1 of 1
Rev	Description	Date	Approbation				

# FEUILLE / SHEET #	DATE CREATION	CREATEUR / CREATOR	REVISION DATE	PAGE
CR352-0017	2018-12-17	allarap	2020-08-31	1 of 1

DESCRIPTION	REVISION PAR / BY	REVISION
Entrouleur #HR-15261718E (Entrée 1/2" et Sortie 1/2") pour série C	trudelj	

# DESSIN / DRAWING #	ECHELLE / SCALE	REVISION
CR352-0017	1:10	1

MSG	
M	S G R E G G S O N
<small> ALL INFORMATION CONTAINED HEREIN IS THE PROPERTY OF MSG AND IS TO BE USED FOR THE EXCLUSIVE USE OF THE CLIENT. NO PART OF THIS DOCUMENT IS TO BE REPRODUCED OR TRANSMITTED IN ANY FORM OR BY ANY MEANS, ELECTRONIC OR MECHANICAL, INCLUDING PHOTOCOPYING, RECORDING, OR BY ANY INFORMATION STORAGE AND RETRIEVAL SYSTEM. WITHOUT PERMISSION IN WRITING FROM MSG, THIS DOCUMENT IS TO BE KEPT CONFIDENTIAL AND NOT TO BE DISCLOSED TO ANY OTHER PARTY. ALL RIGHTS ARE RESERVED. </small>	

Tous les valeurs sont en	
1. Valeurs en inches	
2. Tolérances générales	
GENERAL TOLERANCES	
Angles ± 1°	
X.X ± 0.1"	
X.XXX ± 0.005"	

SCHEMA D'ASSEMBLAGE • DRAWING ASSEMBLY

#	REF.	Q.	L"
1	LV-12N	1	120"
2	LV-12N	1	1200"

LONGUEUR BOYAUX ALIMENTATION	
MODELE	LONGUEUR APPROXIMATIVE
C200	120"
C300	120"
C400	120"
LWT535	60"
LWT735	60"

#	REF.	Q.
3	HR-18221718	1
4	BT-5161	4
5	BT-FW516	4
6	BT-LW516	4
7	BT-N516	4
8	JB-IMB0808BR	1
9	DA-SHAS16	4
10	JB-EL1010NY	1
11	JB-RB1121NY	1
12	JB-A112PG	1
13	JB-IMB0608BR	1
14	JB-C1PG	1

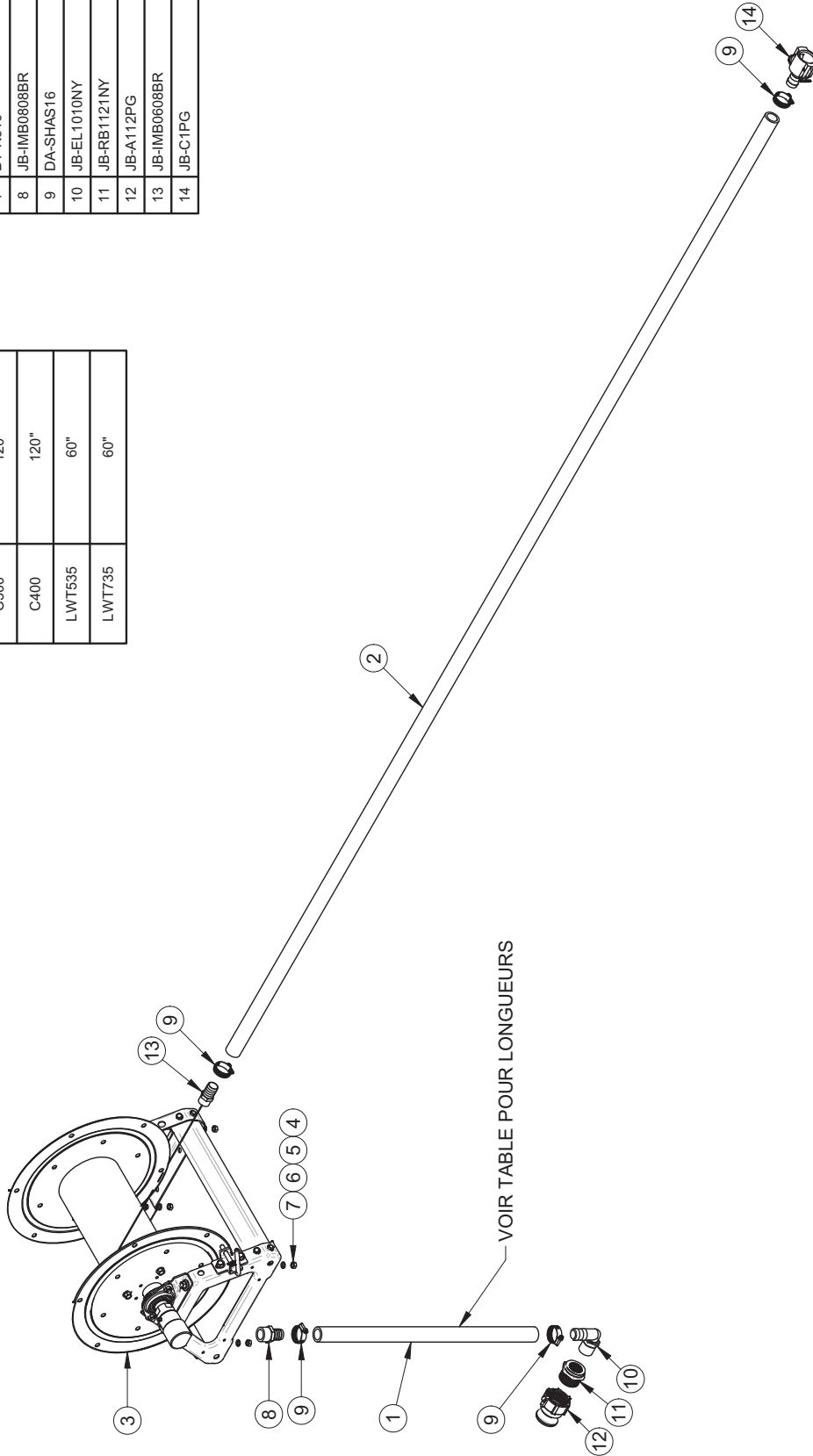

1- LES VALEURS SONT EN POUCES SAUF SI SPECIFIE UN AUTRE SYSTEME DE UNITS
 2- TOLERANCES GENERALES
 C: ± 0.005
 F: ± 0.010
 H: ± 0.015
 K: ± 0.020
 M: ± 0.030
 N: ± 0.040
 P: ± 0.050
 R: ± 0.060
 S: ± 0.070
 T: ± 0.080
 U: ± 0.090
 V: ± 0.100
 X: ± 0.150
 Y: ± 0.200
 Z: ± 0.250

AVIS: Information is provided as a service to our customers. It is not intended to constitute a contract. The user must verify the accuracy of the information provided. MS GREGSON, Inc. reserves the right to modify the information provided without notice. Information disclosed herein is the property of MS GREGSON, Inc. and is the property of the user. No part of this drawing may be reproduced without the written permission of MS GREGSON, Inc.



# FEUILLE / SHEET #	DATE CREATION	CREATEUR / CREATOR	REVISION / DATE	PAGE
CR352-0050	2010-05-12	lessonneaudd	2020-03-13	1 of 1
DESCRIPTION			REVISION / PART / BY	REVISION
Enrouleur #HR-18221718 (Entrée 1 1/2" et Sortie 1")			trudelj	2
#DESSIN / DRAWING #			ECHELLE / SCALE	
CR352-0050			1:40	

Rev	Description	Date	Approval
2	Tablet #P-SM1520PP LV-12N 18in AS-GH1	2020-03-13	trudelj

SCHEMA D'ASSEMBLAGE • DRAWING ASSEMBLY

#	REF.	Q.	L"
1	LV-12N	1	120"
2	LV-12N	1	1200"

LONGUEUR BOYAUX ALIMENTATION	
MODELE	LONGUEUR APPROXIMATIVE
C200	120"
C300	120"
C400	120"
LWT535	60"
LWT735	60"

#	REF.	Q.
3	HR-18221718E	1
4	BT-5161	4
5	BT-FW516	4
6	BT-LW516	4
7	BT-N516	4
8	JB-IMB0808BR	1
9	DA-SHAS16	4
10	JB-EL1010NY	1
11	JB-RB1121NY	1
12	JB-A112PG	1
13	JB-IMB0608BR	1
14	JB-C1PG	1

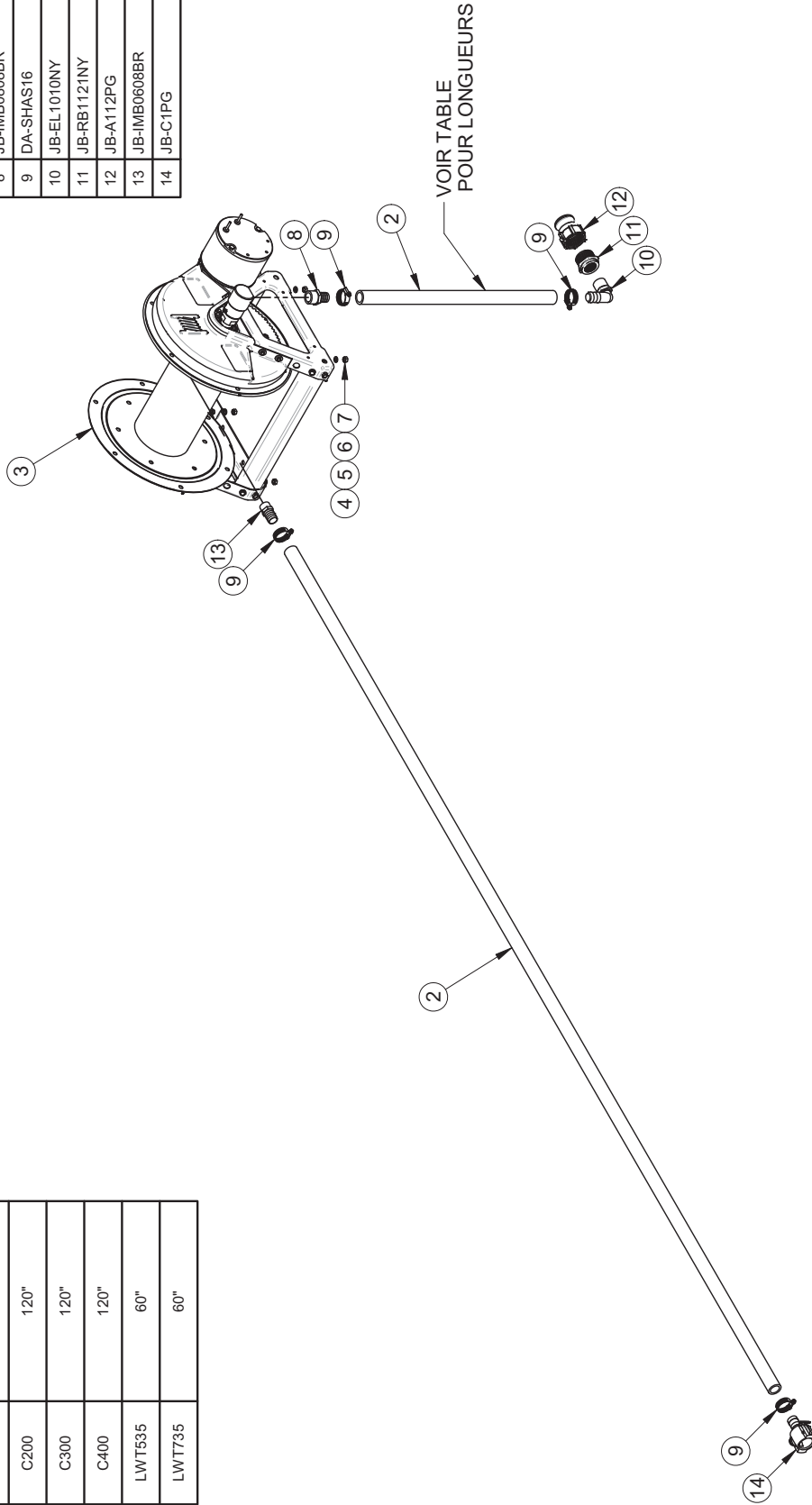

<p>1- LES VALEURS SONT EN POUCE SAUF SI SPECIFIE AUTrement. UNLESS SPECIFIED, DIMENSIONS ARE IN INCHES UNLESS OTHERWISE SPECIFIED.</p> <p>2- TOLERANCES GENERALES: FRACTIONS: .005" - .010" XXV. ± 0.1" XXX. ± 0.1" XXXX. ± 0.105"</p>		<p># FEUILLE / SHEET # CR352-0051</p> <p>DATE CREATION 2010-11-12</p> <p>CREATEUR / CREATOR lessonneau</p> <p>REVISION PAR / BY trudejl</p> <p>REVISION REVISION</p> <p>ECHELLE / SCALE 1:40</p> <p>PAGE 1 of 1</p>
<p>MSG M S G R E G S O N</p>		<p>DESCRIPTION Entouleur #HR-18221718E (Entrée 1 1/2" et Sortie 1")</p> <p>#DESSIN / DRAWING # CR352-0051</p>
<p>1 Description</p>		<p>1 Revision</p>

SCHEMA D'ASSEMBLAGE • DRAWING ASSEMBLY

#	REF.	Q.
1	DO-761022	1
2	AU-7321	1
3	AU-CRSZY0837	1
4	BT-14114	2
5	BT-FW14	4
6	DO-761019	3
7	AU-CRSZY0825	1
8	AU-7250	1
9	AU-1554K2GY	1
10	BT-N14	2
11	BT-LW14	2
12	AU-CD13NABK	2
13	AU-CD16N6BK	1
14	AU-SB50	1

#	REF.	Q.	L"
15	BE-161R	2	6 in
16	AU-K6	1	96 in
17	GT-TEW06RO	1	96 in



OPTION
Démarreur électrique sur moteur
Electric start on motor

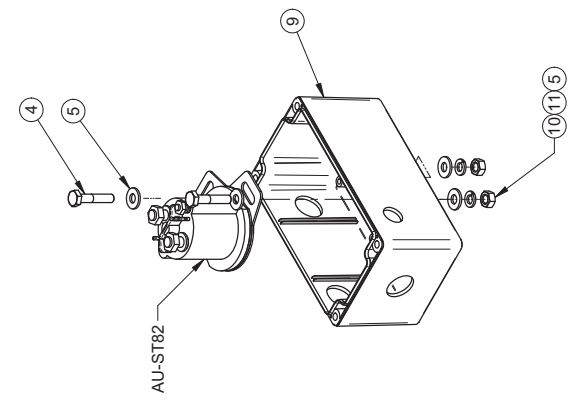
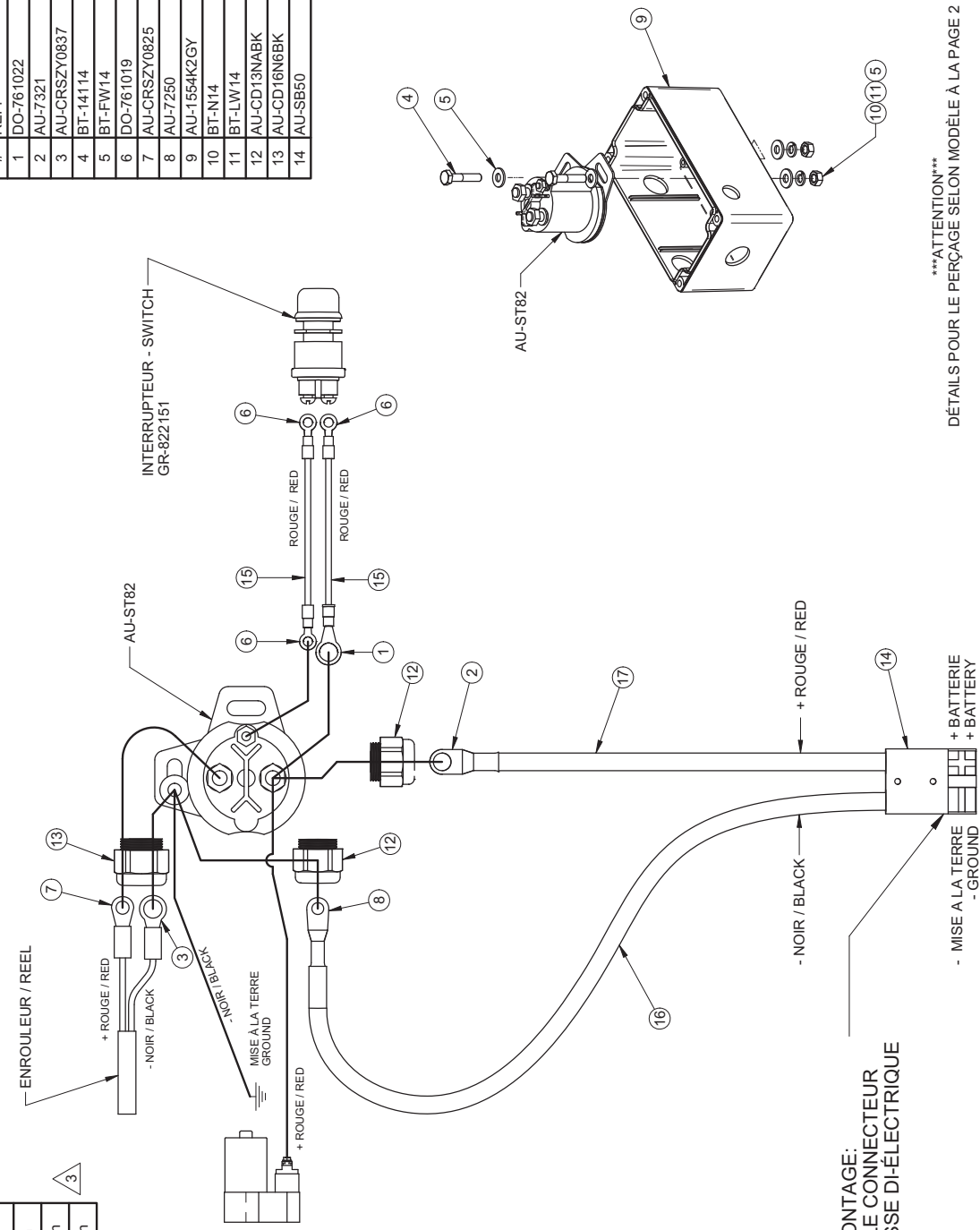

NOTE AU MONTAGE:
LUBRIFIER LE CONNECTEUR
AVEC GRAISSE DIELECTRIQUE

ATTENTION
DÉTAILS POUR LE PERÇAGE SELON MODELE A LA PAGE 2

Rev	Description	Date	Approbation
3	Longueur fil élargi 48"	2021-02-10 (trudelj)	
2	Revision générale, ajout détail perçage selon modèle	2020-11-23 (trudelj)	
1	Modèle AU-SB50	2020-02-23 (trudelj)	

# FEUILLE / SHEET #	DATE CREATION	CREATEUR / CREATOR	REVISION / DATE	PAGE
CR390-0007	2018-12-21	trudelj	2021-02-10	1 of 2

DESCRIPTION	REVISION / PAR / BY	REVISION / SCALE
Boîtier raccordement électrique (enrouleur 12 Vcc)	trudelj	1:5

# DESSIN / DRAWING #	REVISION
CR390-0007	3

AVIS: Information continue à être lue par MS GREGGON, qui est relative aux communications, fabrication et/ou livraison de produits, services, procédures et processus, logiciels, etc.
NOTICE: Information disclosed herein is the property of MS GREGGON, who reserves all rights therein.

1- LES VALEURS SONT EN POUCES SAUF SI SPECIFIE
UNLESS SPECIFIED, DIMENSIONS ARE IN INCHES UNLESS SPECIFIED
2- TOLERANCES GENERALES
Angles: ± 1°
XX: ± 0.1"
XXX: ± 0.05"

SCHEMA D'ASSEMBLAGE • DRAWING ASSEMBLY

#	REF.	Q.	L"
4	AU-K6	1	72 "
5	GT-TEW06RO	1	240 "

#	REF.	Q.
1	AU-SB50	1
2	AU-7321	1
3	CR390-0112-KIT	1



INSTALLATION PAR LE CLIENT / CUSTOMER INSTALLATION

PASSE-FILS POUR FOND DE BOÎTE CAMION
GROMMET FOR PICKUP BOX FLOOR

MISE À LA TERRE À FIXER AU CHÂSSIS DU VÉHICULE
GROUND TO FIX TO THE CHASSIS OF THE VEHICLE

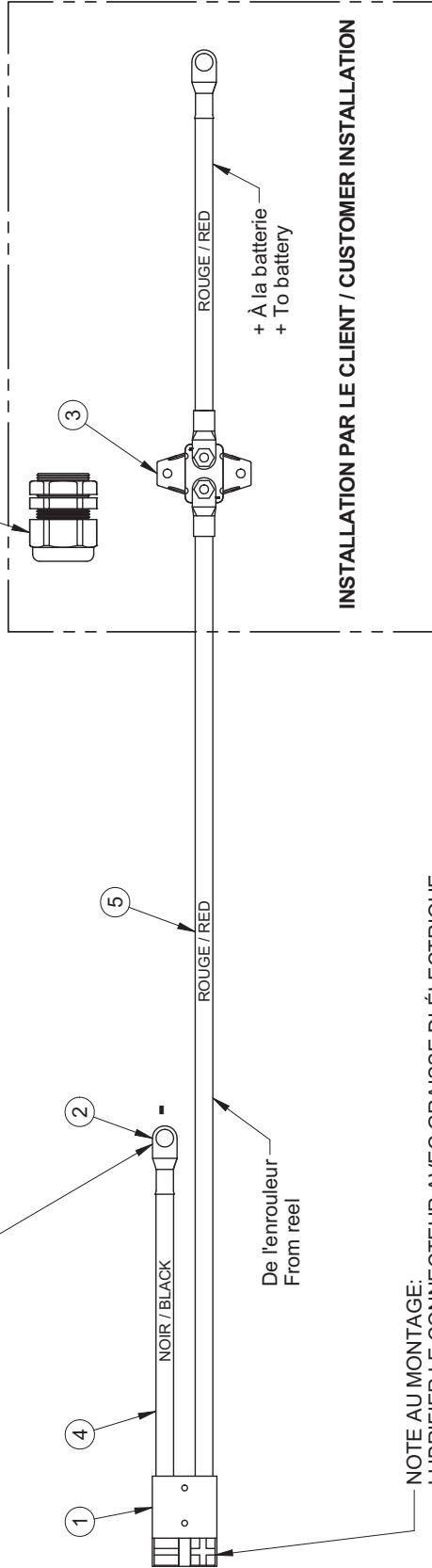

NOTE AU MONTAGE:
LUBRIFIER LE CONNECTEUR AVEC GRAISSE DI-ÉLECTRIQUE

# FEUILLE / SHEET #		DATE CREATION	CREATEUR / CREATOR	REVISION DATE	PAGE
CR390-0112		2010-11-10	lessonneauud	2021-03-29	1 of 1
DESCRIPTION		REVISION PAR / BY			
Raccordement électrique (disjoncteur 40 A)		trudelj			
#DESSIN / DRAWING #		ECHELLE / SCALE			
CR390-0112		1:40			
REVISION		4			

Tous les valeurs sont en	
1. Valeurs en	INCHES
2. Tolérances générales	± 0.10
3. Tolérances	± 0.05
4. Angle	± 0.1°
5. X.XX ± 0.01"	
6. X.XXX ± 0.005"	

4	3	2	1
Remplacez les pièces installées par le client par un KIT	Rapporter AU-C201NASK	RAPPORTER AU-SB50 et AU-K6	ST-TEW06RO et AU-K6
29-03-2021 (trudelj)	14-02-2021 (trudelj)	24-02-2021 (trudelj)	16-01-2018 (trudelj)
Date	Date	Date	Date
Approbation	Approbation	Approbation	Approbation

SCHEMA D'ASSEMBLAGE • DRAWING ASSEMBLY

#	REF.	Q.	L"
6	GT-TEW06RO	1	18 "

#	REF.	Q.
1	AU-CD21NABK	1
2	AU-R2G10S	2
3	AU-CB6378	1
4	AU-7321	1
5*	AU-SAZL44	1

PASSE-FILS POUR FOND DE BOÎTE CAMION
GROMMET FOR PICKUP BOX FLOOR

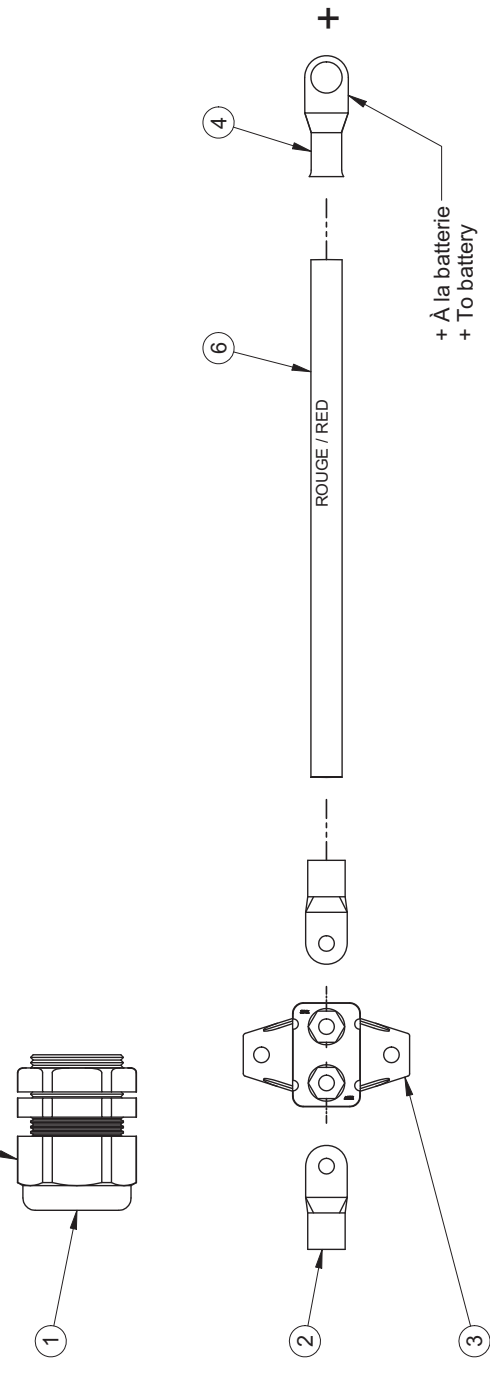

INSTALLATION PAR LE CLIENT / CUSTOMER INSTALLATION

# FEUILLE / SHEET # CR390-0112-KIT DESCRIPTION Ensemble pour installation raccordement électrique (disjoncteur 40 A) #DESSIN / DRAWING # CR390-0112-KIT	DATE CREATION 2021-03-29 CREATEUR / CREATOR tessonmeaud	REVISION PAR / BY trudejil ECHELLE / SCALE 1:40	REVISION 0
* LES VALEURS SONT EN MILLIMETRES * VALUES ARE INCHES * TOLERANCES GENERALES X.X ± 0.1 X.XX ± 0.05 X.XXX ± 0.005*			
Rev.	Description	Date	Approbation

SCHÉMA D'ASSEMBLAGE • DRAWING ASSEMBLY

MS-FULESCO

REF	DESCRIPTION	Q
1	DA-SHAS6	1
2	JB-Z699034	1
3	LE-007433	1
4	JB-CP2567040NY	1

4 gpm - 15 l/min

Partis / pièces : LE-007642, internal assembly repair kit
ensemble de piston interne

MS-FUTEEJET

REF	DESCRIPTION	Q
1	DA-SHAS6	1
2	JB-Z699034	1
3	JB-Z56600	1
4	JB-CP2567040NY	1

4 gpm - 15 l/min

Partis / pièces : JB-ABZ5660, internal assembly repair kit
ensemble de piston interne

Option PC00611

Kit de connecteur rapide à sec
Dry female quick coupler kit

REF	DESCRIPTION	Q
1	JB-3HSB	1
2	AU-441268	1

MS-QCLESCO

Kit de boyau et coupleur mâle à sec
Dry male quick coupler with hose

REF	DESCRIPTION	Q
1	JB-JMB0304BR	1
3	JB-3HPB	1
4	DA-SHAS6	1
5	LV-1224IN (PO-IN)	42

Buses recharge / spare nozzles

Kit de boyau et coupleur mâle à sec
Dry male quick coupler with hose

REF	DESCRIPTION	Q
1	JB-CP2567030NY	1
2	JB-CP2567015NY	1

MS-FULESCO	MS-FUTEEJET	PC00560	PC00559
DESCRIPTION	DESCRIPTION	DESCRIPTION	DESCRIPTION
MS-FULESCO	MS-FUTEEJET	MS-FULESCO	MS-QCLESCO
Q	Q	Q	Q
1	1	1	1

# FEUILLE / SHEET #	DATE CREATION	CREATEUR / CREATOR	REVISION DATE	PAGE
2001-10-16	2001-10-16	P.B.	2020-03-18	1 / 1

DESSIN / DRAWING # Pistolets-Lesco-Teejet.vcp

MS-GREGGON

MS GREGGON

MS GREGGON

DESCRIPTION : Pistolets gazons MS-FULESCO / MS-FUTEEJET
Lawnm care guns MS-FULESCO / MS-FUTEEJET

REVISION / BY : R.D.
Echelle / Scale : 1

Pistolets à fleurs - Watering guns

MS-FUFLEUR		
#	Description	Q.
1	JB-3HPB	1
2	JB-RMM0304NY	1
3	MP-2919039	1
4	MS-TA36FF	1
5	JB-IHE0004NY40	1
6	AU-400A	1

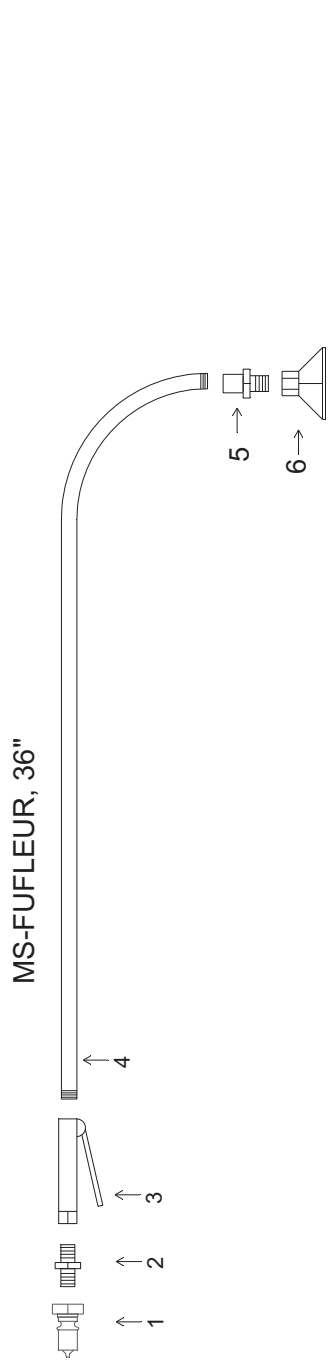

MS-FU8FLEUR		
#	Description	Q.
1	JB-3HPB	1
2	JB-RMM0304NY	1
3	MP-2919039	1
4	MS-TA40FF	1
5	JB-IHE0004NY40	1
6	AU-400A	1
7	JB-CFE044BR	1
8	MS-TA48FF	1

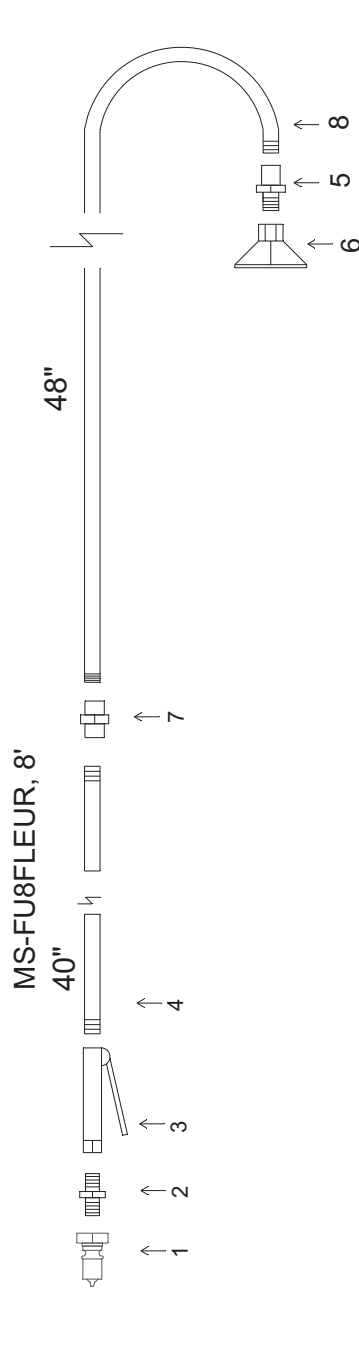

<p>1. LES VALEURS SONT EN POUCES SAUF INDICATION CONTRAIRE</p> <p>UNLESS SPECIFIED OTHERWISE, DIMENSIONS ARE IN INCHES</p> <p>GENERAL TOLERANCES ARE AS FOLLOWS:</p> <p>XXX ± 0.1"</p> <p>XXXX ± 0.005"</p>		<p>DATE: THIS DRAWING IS THE PROPERTY OF MSG GREGGSON. IT IS TO BE USED ONLY FOR THE PROJECT AND NOT FOR REPRODUCTION, DISTRIBUTION, OR FOR ANY OTHER PURPOSE WITHOUT THE WRITTEN PERMISSION OF MSG GREGGSON.</p>		<p>DATE CREATION: 1987-06-27</p> <p>REVISION DATE: 2020-03-16</p>	
<p>MS-GREGGSON</p>		<p>MS-FUFLEUR.REV3</p> <p>Pistolets à fleurs / pompes membranes</p> <p>Watering guns for diaphragm pumps</p>		<p>CREATEUR / CREATOR: R.D.</p> <p>REVISION PAR / BY: R.D.</p>	
<p>3. Aucun changement, enlever les pistolets entiers à came</p> <p>Rev Description</p>		<p>2020-03-16, R.D.</p> <p>Date</p>		<p>MS-FUFLEUR</p> <p>MS-FU8FLEUR</p> <p>MS-FUFLEUR</p> <p>MS-FU8FLEUR</p>	
<p>Approval</p>		<p>DESSIN / DRAWING # Fufleur.rev3</p>		<p>ECHELLE / SCALE: 8 / 1</p> <p>REVISION: 3</p>	

#	REF.	Q.
1	GG-JD9C	1
2	JB-RMM0304BR	1
3	JB-3HPB	1

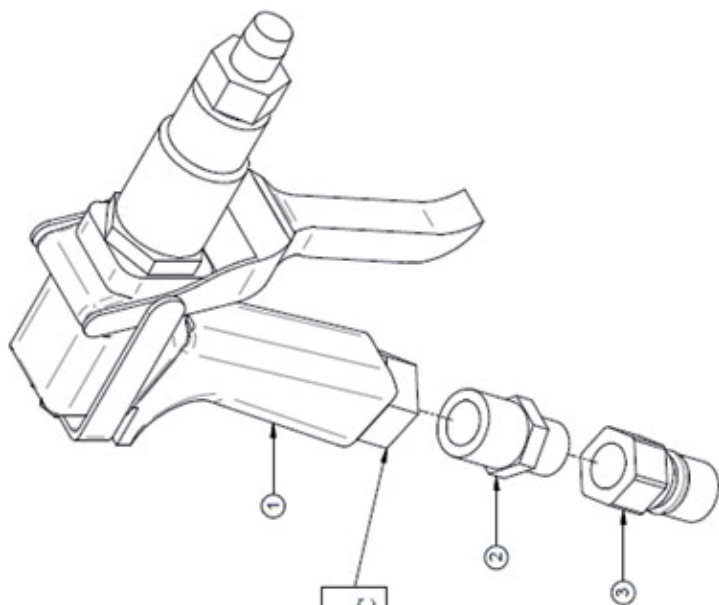

NOTE:
Enlever l'adaptateur du pistolet JD9C

NOZZLES AND TIPS APPROX. FLOW RATES		
Part No.	Capacity - GPM	
GG-101SX	.3 - 1	
GG-101S	1 - 3	
GG-101M	2 - 5	
GG-101L	3 - 8	
GG-101LX	10 - 19	
GG-101FB	4 - 5	
GG-101FA	5 - 7	

(KIT RÉPARATION PISTOLET / GUN REPAIR KIT # GG-101C)

SCHÉMA D'ASSEMBLAGE • DRAWING ASSEMBLY

MS-JD9CSLQC

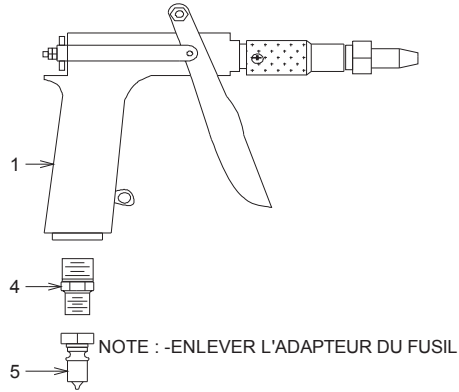

MS-FU33QC
MS-FU33LQC

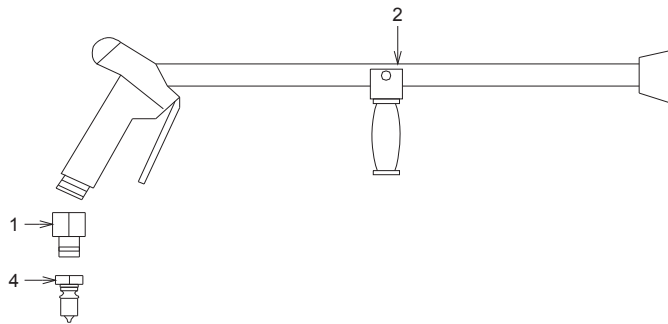

	PULVÉRISATEUR MS Inc.		
	PULVCOMPCIFUARBRE		
DATE: 2001-10-15	PAR: P.B.		
REV: 2006-03-16	PAR: D.T.	#REV: 0	
TITRE: FUSILS A ARBRE SUR Q-C			
# REC.: MS-JD9CSLQC			
MS-FU33QC			
MS-FU33LQC			APP:

SCHÉMA D'ASSEMBLAGE • DRAWING ASSEMBLY



MS Gregson Inc.
4300 rue Vachon, Drummondville QC J2B 6V4, Canada
Tél.: 819 474-1910 • Fax : 819 474-5317 • orders@msgregson.com

BOM	MS-FU33QC
REVISION	0

Desc. Française	§ Pistolet n°33 à portée moyenne sur coupleur rapide
English Desc.	§ No 33 medium range spray gun on quick-coupler

Réf.	Quantité	Produit	Description française	English Description
1	1.00	AU-120DC	Réduct 1/2"fnpt x 3/8"mnpt oed.40 laiton	Reducer 1/2"fnpt x 3/8"mnpt oed.40 br
2	1.00	JB-33810010	Fusil arbre no. 33, buse 3mm	No. 33 tree spray gun, 3mm nozzle
2	1.00	JB-33812300	Buse 2.2 mm	Nozzle 2.2 mm
4	1.00	JB-3HPB	Co a bille fermé mâle 3/8" x 3/8"fnpt br	Close ball coupler male 3/8" x 3/8"fnpt br

SCHÉMA D'ASSEMBLAGE • DRAWING ASSEMBLY

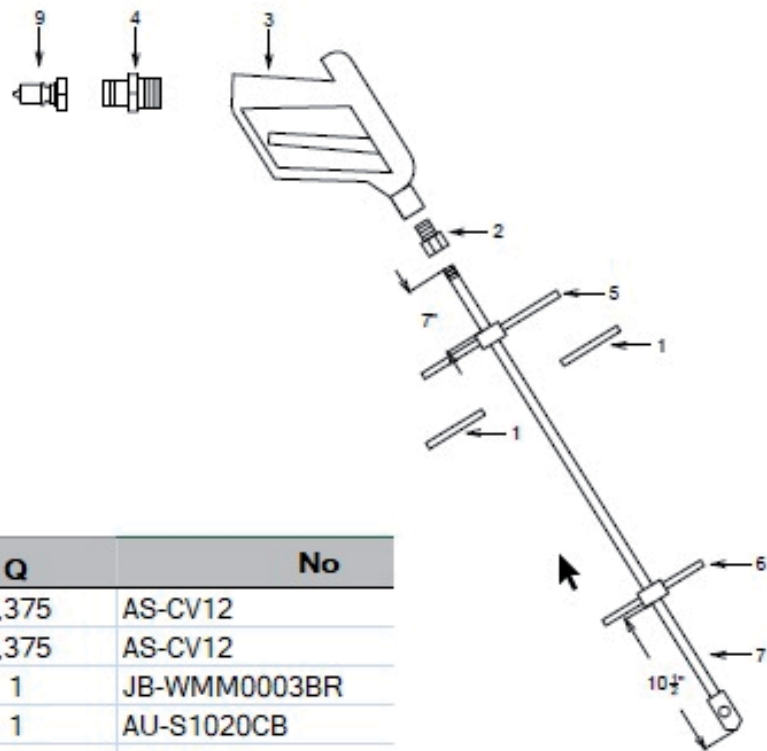

Reference	Q	No
001	0,375	AS-CV12
001	0,375	AS-CV12
004	1	JB-WMM0003BR
002	1	AU-S1020CB
009	1	JB-3HPB
003	1	AU-DG4000
005	+	MS-INJPA
006	1	MS-INJPIED
007	1	MS-INJT1

		PULVÉRISATEUR MS Inc.	
IPULVCOMPFCUINJACINE			
DATE: 2001-10-16	PAR: P.B.		
REV: 2010-03-16	PAR: D.T.	#REV: 0	
TITRE: INJECTEUR RACINAIRE			
# REC.: MS-MSINJ			
			APP:

SCHEMA D'ASSEMBLAGE • DRAWING ASSEMBLY

#	REF.	Q.
1	DA-BV12	1
2	MS-TA36FF	1
3	JB-IHF0004NY40	1
4	AU-400A	1
5	JB-F12PG	1
6	BJ-RN100050	1
7	JB-A1PG	1

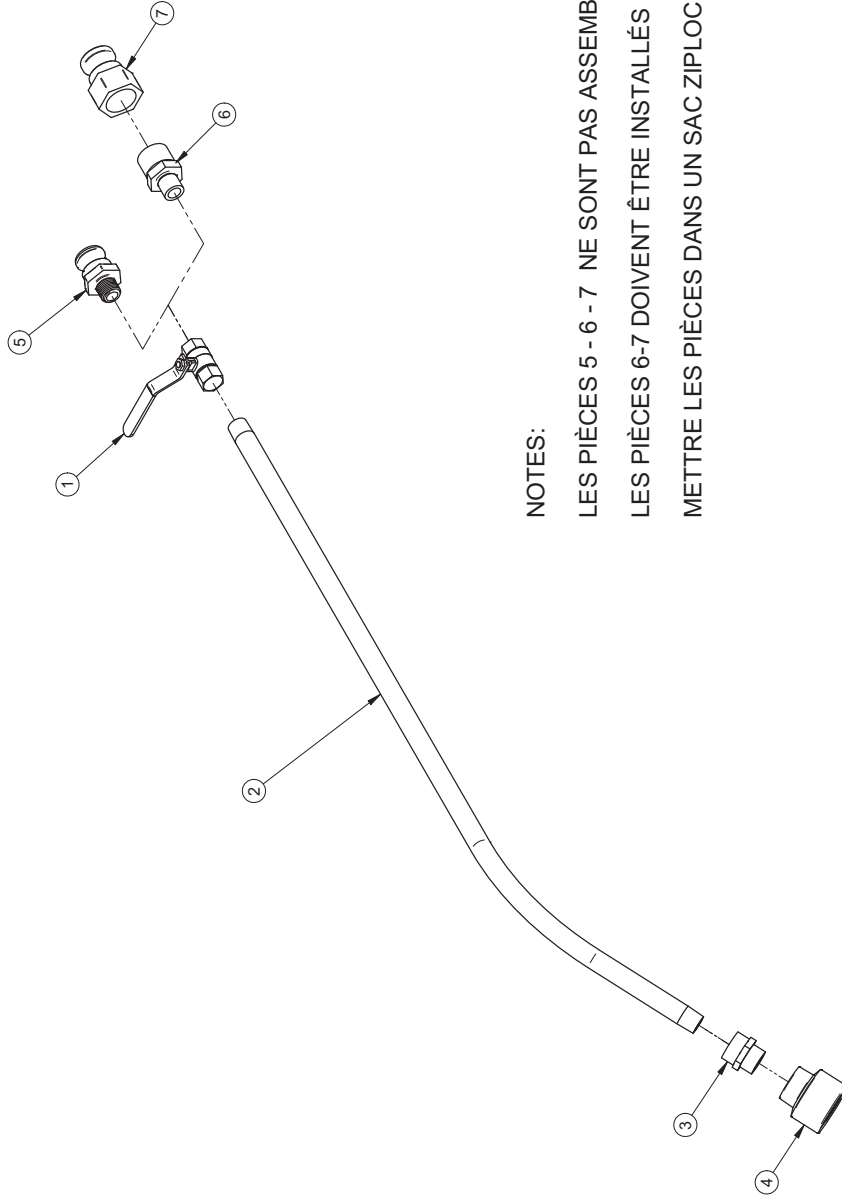

NOTES:
 LES PIÈCES 5 - 6 - 7 NE SONT PAS ASSEMBLÉS SUR LE FUSIL
 LES PIÈCES 6-7 DOIVENT ÊTRE INSTALLÉS ENSEMBLE
 METTRE LES PIÈCES DANS UN SAC ZIPLOC

Rev	Description	Date	Approbation

1. LES VALEURS DONNÉES EN POULCES SAUF LES SPÉCIFIÉS SONT EN MILLIMÈTRES.	# FEUILLE / SHEET #	DATE CREATION	CREATEUR / CREATOR	REVISION DATE	PAGE
2. TOLERANCES GÉNÉRALES: Angles: ± 1° X.XX ± 0.01" X.XXX ± 0.005"	MS-P3FLEUR2	2020-03-13	trudej	2020-03-13	1 of 1
	DESCRIPTION			REVISION PAR / BY	
	Fusil à fleur 3' - vanne à bille sur connecteur à came de 3/4" et de 1"			trudej	
	#DESSIN / DRAWING #			ECHELLE / SCALE	REVISION
	MS-P3FLEUR2			1:0.67	0

#	REF.	Q.
1	DA-BV12	1
2	MS-TA40FF	1
3	JB-CFF0404BR	1
4	MS-TA68FF	1
5	JB-IHF0004NY40	1
6	AU-400A	1
7	JB-F12PG	1
8	BJ-RN100050	1
9	JB-A1PG	1

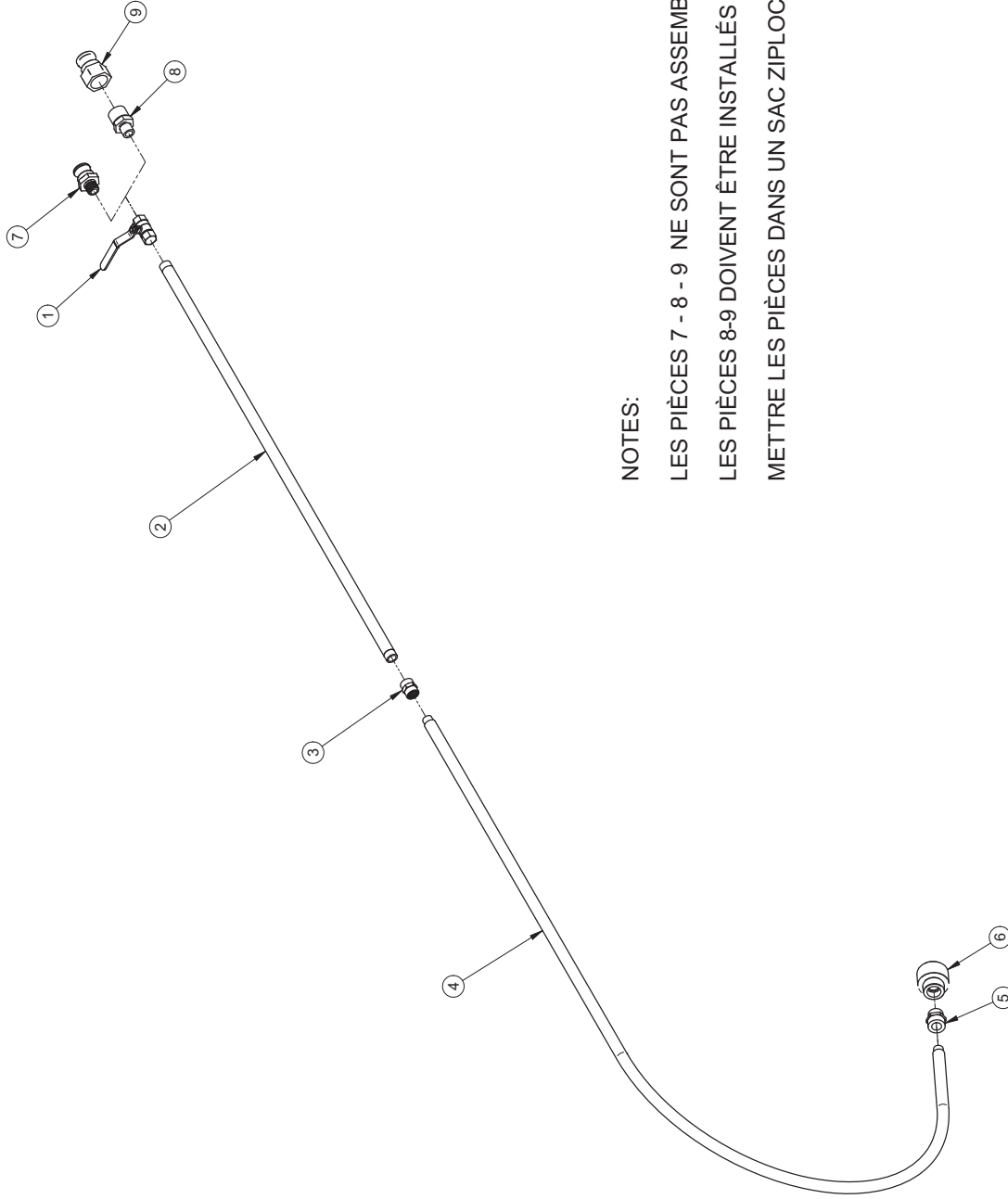

NOTES:
LES PIÈCES 7 - 8 - 9 NE SONT PAS ASSEMBLÉS SUR LE FUSIL
LES PIÈCES 8-9 DOIVENT ÊTRE INSTALLÉS ENSEMBLE
METTRE LES PIÈCES DANS UN SAC ZIPLOC

# FEUILLE / SHEET #	CREATEUR / CREATOR	REVISION DATE	PAGE
MS-P8FLEUR2	trudej	2020-03-13	1 of 1
DESCRIPTION Pistolet 8" pour fleurs, sur came mâle de 3/4" et 1", ball-valve 1/2"			REVISION PART/ BY trudej
#DESSN / DRAWING # MS-P8FLEUR2			REVISION 1:1.1.11 0
1- LES VALEURS SONT EN POUCES SAUF SI SPECIFIÉ PAR AUTRES VALEURS UNLESS SPECIFIED OTHERWISE IN INCHES UNLESS SPECIFIED OTHERWISE IN INCHES 2- GENERAL TO ALL DRAWINGS Fig. - 1, 1/16" X, XX ± 0.01" X, X ± 0.1" X, XXX ± 0.065"			
#FEUILLE / SHEET # MS-P8FLEUR2			
DATE CREATION 2020-03-13			
CREATEUR / CREATOR trudej			
REVISION DATE 2020-03-13			
PAGE 1 of 1			
REVISION PART/ BY trudej			
REVISION 1:1.1.11 0			
Rev	Approved	Date	Representation

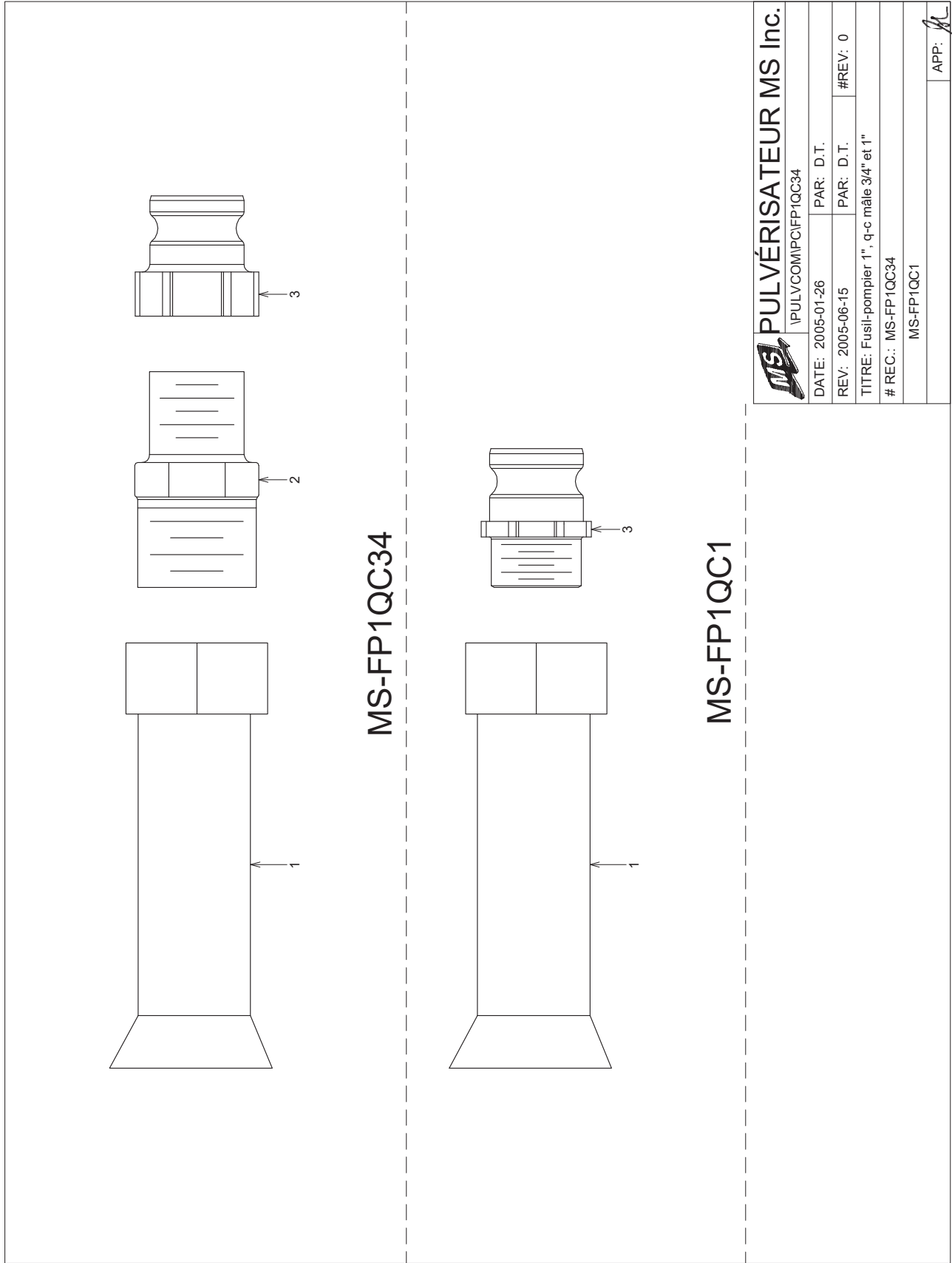

MS-FP1QC34

MS-FP1QC1



 PULVÉRISATEUR MS Inc. \PULVCOM\IPC\FP1QC34	DATE: 2005-01-26	PAR: D.T.
	REV: 2005-06-15	PAR: D.T. #REV: 0
	TITRE: Fusil-pompier 1", q-c mâle 3/4" et 1"	
	# REC.: MS-FP1QC34	
MS-FP1QC1		APP: 

SCHÉMA D'ASSEMBLAGE • DRAWING ASSEMBLY

BOM	MS-FP1QC34
REVISION	0

Desc. Française	§ Buse-pompier 1" avec connecteur à came 3/4" assemblée
English Desc.	§ Fireman-nozzle 1" with cam lever coupling 3/4" assembly

Réf.	Quantité	Produit	Description française	English Description
1	1.00	AS-1030	Buse-pompier en thermoplastique, 1"tpt, 11gpm a 100	Thermoplastic Fireman-nozzle, 1" tpt, 11 gpm at 100psi
2	1.00	BJ-RN100075	Mamelon réducteur 1"mnpt x 3/4"mnpt céd.80 ny	Nipple red. 1"mnpt x 3/4"mnpt ced.80 ny
3	1.00	JB-A34PG	Qc a came mâle 3/4" x 3/4"tpt ny	Cam lever coupler male 3/4" x 3/4"tpt ny

SCHÉMA D'ASSEMBLAGE • DRAWING ASSEMBLY

#	REF.	Q.
1	AS-1575	1
2	BJ-FRN150100	1
3	JB-A1PG	1

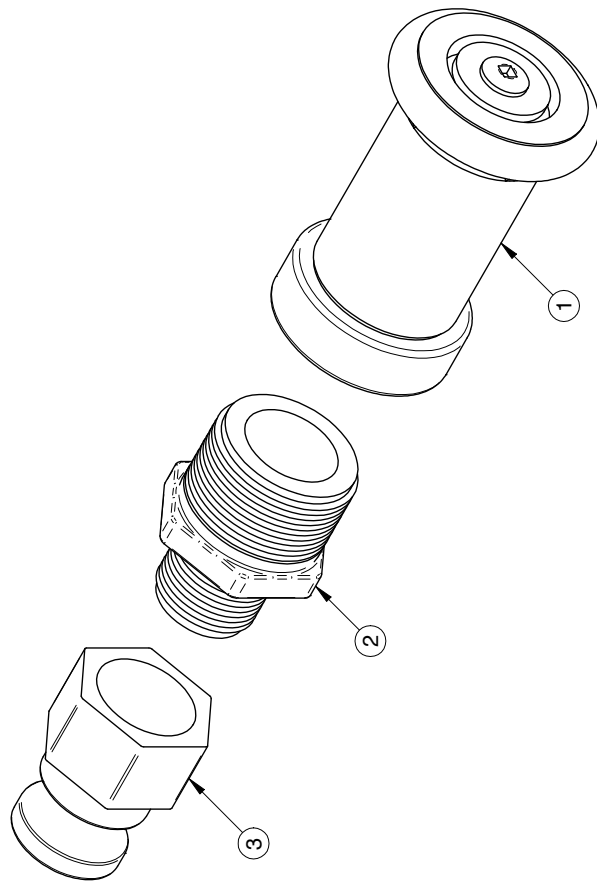

2014/03/26	Pg:1-1
CR354-0003	Rev:0

SCHÉMA D'ASSEMBLAGE • DRAWING ASSEMBLY

APPROUVÉ LE: 2006-06-08 14:13:17 PAR: LANOIEG

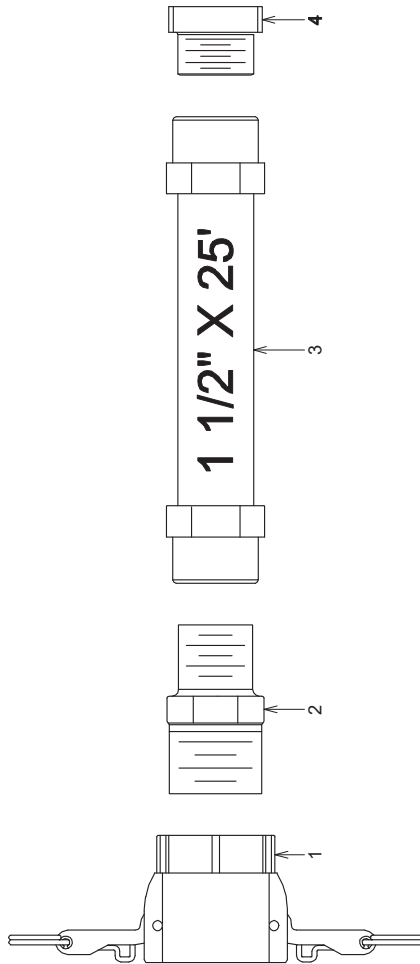



	PULVÉRISATEUR MS Inc.
IPULVCOMHYDROBF2515	
DATE: 2006-06-08	PAR: D.T.
REV:	#REV:
TITRE: Ensemble boyau plat 25' X 1 1/2" à borne fontaine 2 1/2"	
# REC.: MS-BF2515	
APP: 	

SCHÉMA D'ASSEMBLAGE • DRAWING ASSEMBLY

BOM	MS-BF2515
REVISION	0

Desc. Française § Con. à came, 25' bo yau-pompier, adaptateur borne-fontaine
 English Desc. § Cam lever coupling, 25' fireman hose, fire hydrant adapter

Réf.	Quantité	Produit	Description française	English Description
1	1.00	JB-D2PG	Qc a came fem. 2" x 2"tpt ny	Came lever coupler fem. 2" x 2"tpt ny
2	1.00	BJ-RN200150	Mamelon réducteur 2"mnpt x 1 1/2"mnpt céd.60 ny	Nipple red. 2"mnpt x 1 1/2"mnpt ced.60 ny
3	1.00	AS-BP11225FXF	Boyau plat pompier tressé 1 1/2"x 25', 1 1/2"tft	Flat 1 1/2" fireman hose x 25', 1 1/2"tft
4	1.00	AU-09130	Réduit 2 1/2" fem-borne fontaine x 1 1/2"mnpt	Reducer 2 1/2" fem-fire thread x 1 1/2"mnpt

VUES EXPLOSÉES DES COMPOSANTES • PARTS BREAK DOWN

Pompe • Pump

JB-9910D30, JB-9910D30GRGI

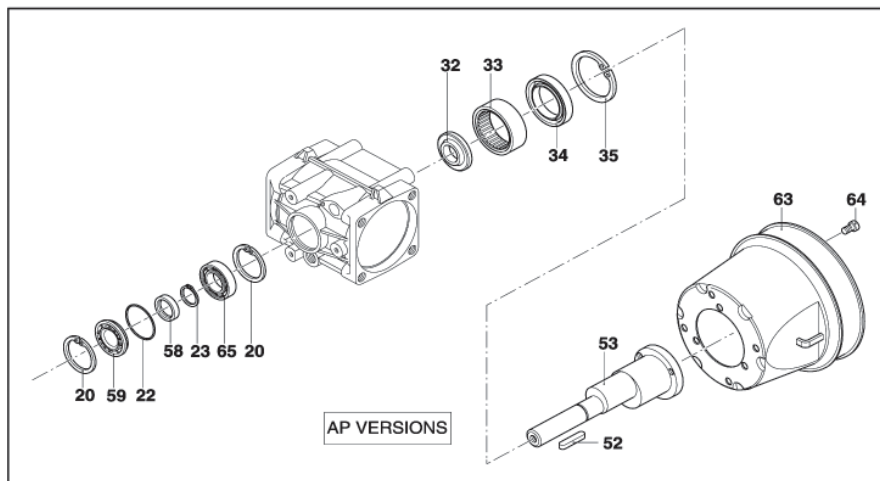
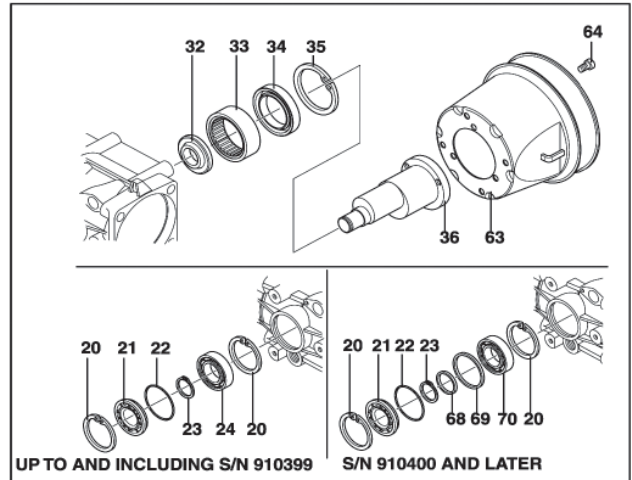
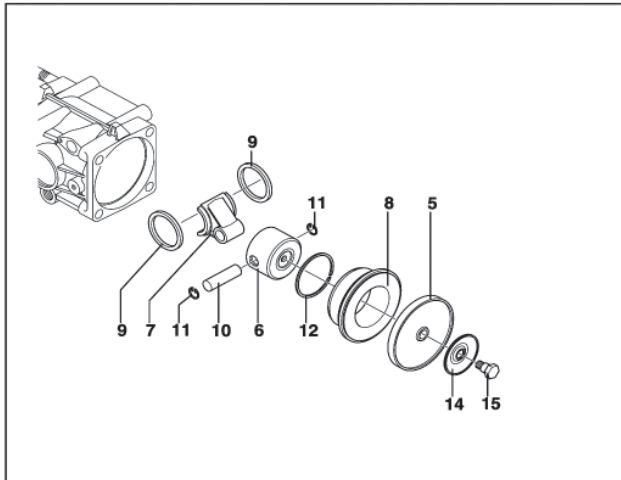
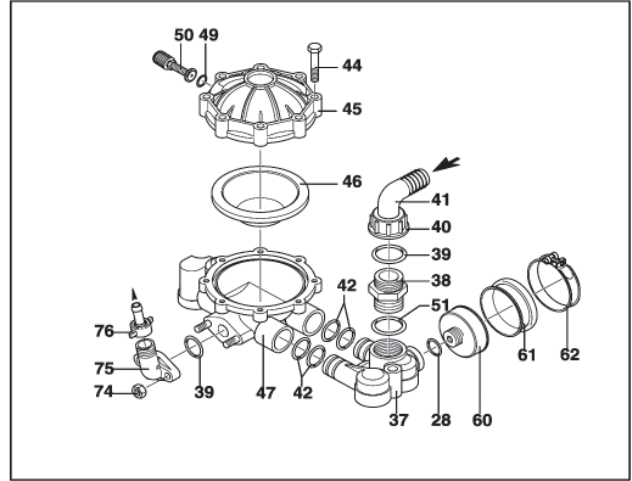
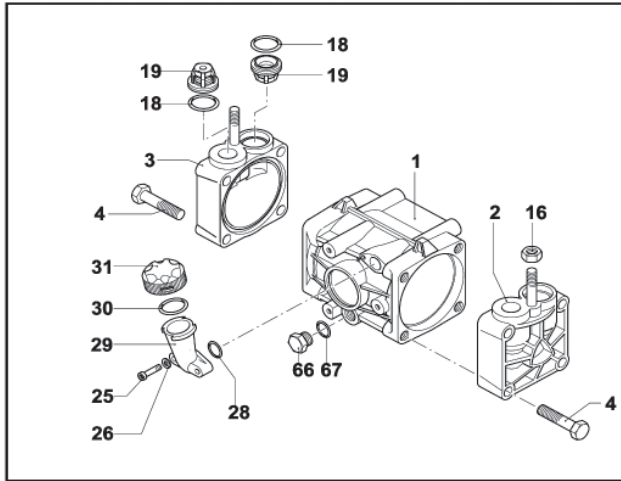

VUES EXPLOSÉES DES COMPOSANTES • PARTS BREAK DOWN

Pompe • Pump

JB-9910D30, JB-9910D30GRGI

REF	N°	DESCRIPTION	Q	REF	N°	DESCRIPTION	Q
1	JB-9910629011	Pump Body w/bolts	1	36	JB-9910620170	Crankshaft	1
2	JB-9910620101	Right Head Assembly (DX)	1	37	JB-9910620150	Suction Manifold	1
3	JB-9910620102	Left Head Assembly (SX)	1	38	JB-9910550340	Threaded Adapter	1
4	JB-9910621430	Bolt 12 x 55	8	39 ³	JB-9910550350	O-Ring	2
5 ¹	JB-9910620085	Diaphragm, Desmopan (Std.)	2	40	JB-9910550242	Ring Nut	1
5	JB-9910620080	Diaphragm, Buna-N (Opt.)	2	41	JB-9910550370	Hose Barb 1"	1
6	JB-9910620120	Piston	2	42 ³	JB-9910390060	O-Ring	4
7	JB-9910620140	Connecting Rod	2	44	JB-9910621780	M8 X 40 Bolt	8
8	JB-9910620110	Sleeve	2	45	JB-9910629211	Upper Air Chamber	1
9	JB-9910580470	Retainer Ring	2	46 ¹	JB-9910550190	Accumulator Diaphragm, Buna-N	1
10	JB-9910380300	Connecting Rod Pin	2	47	JB-9910622070	Lower Air Chamber Body	1
11	JB-9910380080	Ring Pin	4	49 ³	JB-9910650542	O-Ring	1
12	JB-9910160230	Piston Ring	2	50	JB-9910180020	Air Valve	1
14	JB-99101040180	Retaining Washer	2	51 ³	JB-9910390290	O-Ring	1
15	JB-9910580360	Diaphragm Bolt	2	52	JB-9910620680	Key (AP-A Model)	1
16	JB-9910180150	Nut	2	53	JB-9910620172	Thru-Shaft 20 mm Dia. "AP Version"	1
18 ^{1,2,3}	JB-9910620030	O-Ring	4	53	JB-9910620174	Thru-Shaft 3/4" Dia. "AP Version"	1
19 ²	JB-99101409050	Complete Valve Assembly	4	58	JB-9910620630	Seal	1
20	JB-9910111120	Retaining Ring	2	59	JB-9910620021	Cover	1
21	JB-9910620020	Cover	1	60	JB-9910650660	Diaphragm Holder	1
22 ³	JB-9910620210	O-Ring	1	61	JB-9910650670	Suction Diaphragm	1
23	JB-9910620291	Retaining Ring	1	62	JB-9910650690	Clamp	1
24	JB-9910620191	Bearing	1	63	JB-99101500350	PTO Shield	1
25	JB-9910850850	M6 X 30 Bolt	2	64	JB-9910820670	M10 X 16 Bolt	4
26	JB-9910550331	Washer	2	65	JB-9919620190	Bearing	1
28 ³	JB-9910180101	O-Ring	2	66	JB-24060023	Drain Plug, oil	1
29	JB-9910550030	Oil Sight Glass	1	67 ³	JB-9910740290	O-Ring	1
30 ³	JB-9910550040	O-Ring	1	68	JB-9910620930	Spacer	1
31	JB-9910550056	Oil Sight Glass Cap	1	69	JB-9910620940	Spacer	1
32	JB-9910620160	Spacer	1	70	JB-9910380230	Bearing	1
33	JB-9910550060	Roller Bearing	1	74	JB-9910390270	Nut	2
34	JB-9910620130	Seal	1	75	JB-9910450145	Flange	1
35	JB-9910620330	Retaining Ring	1	76	JB-9910110130	1/2" Fitting plus Hose Barb	1

- 1 Denotes Diaphragm Kit 9910-KIT1724
 2 Denotes Valve Kit 9910-KIT1917
 3 Denotes O-Ring Kit 9910-KIT1916

REF	DESCRIPTION	Tightening Torque	
		In. Lbs.	Nm
4	Bolt	393.7	44.1
15	Bolt	262.5	29.4
16	Nut	350.0	39.2
25	M6 x 30 Bolt	87.5	9.8
44	M8 x 40 Bolt	175.0	19.6
64	M10 x 16 Bolt	87.5	9.8
74	Nut	175.0	19.6

JB-9910-KIT1724 Diaphragm Kit Desmopan	
Ref. No.	Qty.
5	2
18	4
46	1

JB-9910-KIT1917 Valve Kit	
Ref. No.	Qty.
18	4
18	4

JB-9910-KIT1916 O-Ring Kit	
Ref. No.	Qty.
18	4
22	1
28	2
30	1
39	2
42	4
49	1
51	1
67	1

Réducteur • Gear box

JB-9910KIT1640

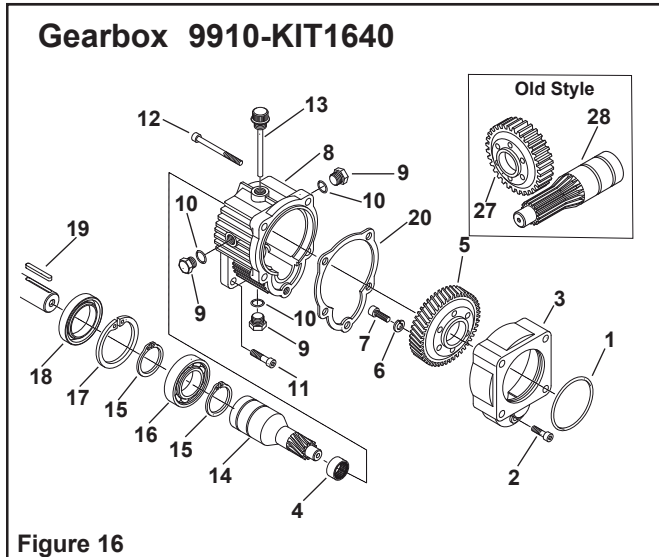

Ref. No.	Part Number	Description	Qty.
1	JB-9910620561	O-Ring	1
2	JB-9910180030	M8 x 20 Bolt	1
3	JB-9910621000	Pump Adapter Flange	1
4	JB-9910620990	Bearing	1
5	JB-9910651620	Gear	1
6	JB-9910200231	Lock Washer	6
7	JB9910620470	M10 x 20 Bolt	3
8	JB9910620960	Gearbox Body	1
9	JB-24060023	Plug	2
10	JB-9910740290	O-Ring	2
11	JB-9910651000	5/16 x 24 UNF x 1 Bolt	4
12	JB-9910621010	M10 x 75 Bolt	4
13	JB-99101140370	Vent Plug	1
14	JB-9910621660	Pinion Gear	1
15	JB-9910320240	Retaining Ring (Ext.)	2
16	JB-9910961780	Bearing	1
17	JB-9910961790	Retaining Ring (Int.)	1
18	JB-9910961800	Seal	1
19	JB-9910881090	Key	1
20	JB-9910620950	Gasket	1
27	N/A	Gear	1
28	N/A	Pinion Gear	1

Ref. No.	Description	Tightening Torque	
		In. Lbs.	Nm
2	Bolt	218.7	24.5
7	Bolt	171.4	19.6
9	Plug	171.4	19.6
11	Bolt	218.7	24.5
12	Bolt	218.7	24.5

VUES EXPLOSÉES DES COMPOSANTES • PARTS BREAK DOWN

Vanne régulatrice de pression • Pressure relief valve

JB-9910GS40GI

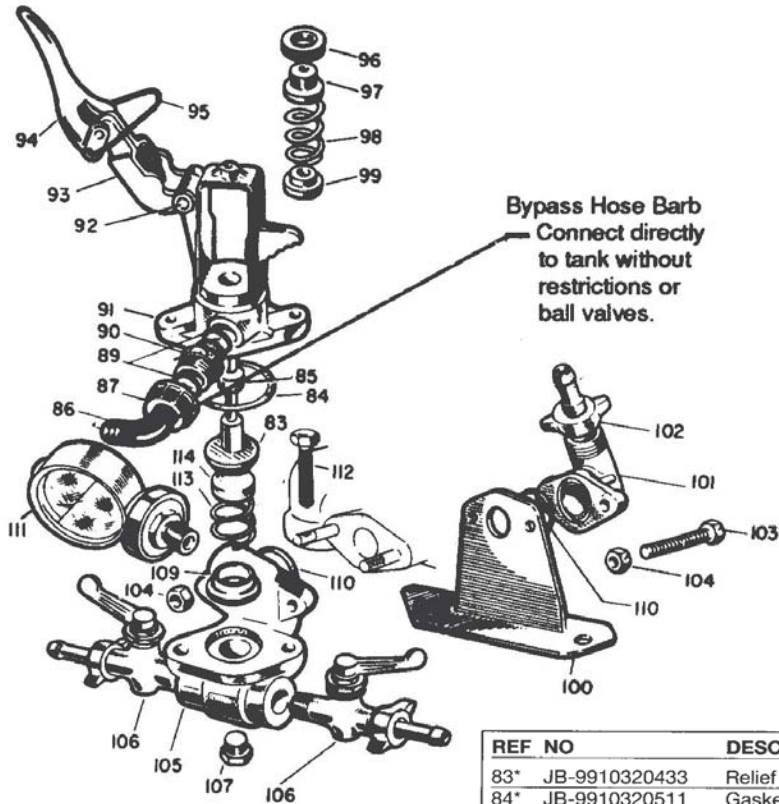

REF NO	DESCRIPTION	Q
83*	JB-9910320433 Relief valve poppet retainer	1
84*	JB-9910320511 Gasket seal O-ring	1
85*	JB-9910390140 Tension spring guide / seal	1
86	JB-9910550460 Hose barb 3/4"	1
87	JB-9910550450 Barb nut	1
89	JB-9910180101 O-ring	2
90	JB-9910550440 Threaded adapter	1
91	JB-9910320410 Tension spring housing	1
92	JB-9910320480 Pin	2
93	JB-9910320460 Lever guide	1
94	JB-9910320470 Pressure release lever	1
95	JB-9910320490 Locking clip	1
96	JB-9910320450 Pressure adjustment nut	1
97	JB-9910320440 Threaded guide	1
98	JB-991010190 Tension spring	1
99	JB-9910620810 Tension spring (opt.) (for under 100 psi)	1
100	JB-9910230120 Tension spring retainer	1
100	JB-9910320406 Remote discharge mounting bracket	1
101	JB-9910450145 Discharge flange housing	1
102	JB-991010130 1/2" hose barb & nut 3/8" (JB-991010131)	1
103	JB-9910160660 Bolt (8MA x 35)	2
104	JB-9910390270 Nut	2
105	JB-9910620220 Relief valve body	1
106	JB-991030490 Ball valve	2
107	JB-991030171 Plug	1
109*	JB-9910450110 Seal	1
110	JB-9910550350 O-ring	1
111	JB-26400001 Pressure gauge (oil filled)	1
112	JB-9910180370 Bolt (8MA x 25)	1
113*	JB-9910320420 Tension spring	2
114*	JB-991010121 Relief valve seat	1
REPAIR & MAINTENANCE KIT AVAILABLE		
*	JB-9910KIT1757 Control unit parts kit	

VUES EXPLOSÉES DES COMPOSANTES • PARTS BREAK DOWN

Pompe • Pump

BJ-200PO, BJ-205PO, BJ-300PO

Note : 2" = BJ-200PO, BJ-205PO
3" = BJ-300PO

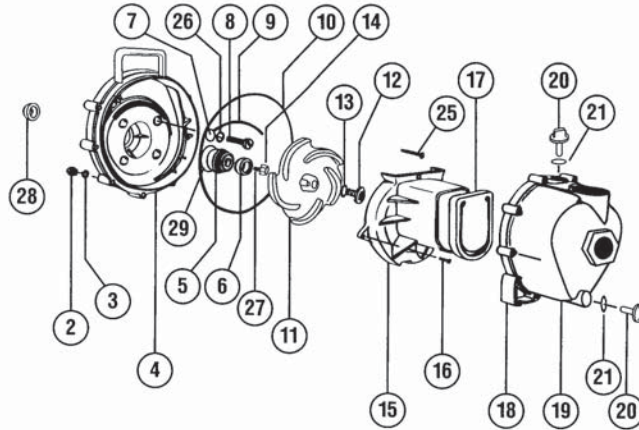

REF	2"	3"	Description	Q
2	BJ-V07019	BJ-V07019	Body nuts	10
3	BJ-V07018	BJ-V07018	Lock washer	10
4	BJ-12703A	BJ-12703A	Rear bracket	1
5-6*	BJ-12713	BJ-12713	Seal Assy	1
7*	BJ-12717	BJ-12717	Screw head o-ring	4
8	BJ-12715A	BJ-12715A	Bracket screw	4
9*	BJ-12754	BJ-12754	O-ring segment	1
10*	BJ-12719A	BJ-12719A	Body o-ring	1
11	BJ-12771A		Impeller (3 vanes)	1
	BJ-12772		Impeller (5 vanes) (BJ-205PO)	1
		BJ-13771	Impeller (4 vanes)	1
12	BJ-12765A	BJ-13765	Impeller stud	1
13*	BJ-12774VA	BJ-12774VA	O-ring acorn nut	1
14	BJ-12775A	BJ-12775A	Acorn nut	1
15	BJ-12702A	BJ-13702	Volute	1
16	BJ-12725	BJ-12725	Volute screws	2
17*	BJ-12705	BJ-12705	Check valve	1
18	BJ-12712A	BJ-13712	Body	1
19	BJ-12720	BJ-12720	Body screws	10
20	BJ-12777	BJ-13777	Prime plug	2
21*	BJ-UV15163	BJ-13778	Prime plug O-ring	2
25	BJ-12900	BJ-12900	Upper volute screw	1
26	BJ-12901	BJ-12901	1/4" washer, s. steel	4
27	BJ-12902A	BJ-12902A	Impeller key	1
28*	BJ-12706	BJ-12706	Slinger o-ring	3
29*	BJ-12710	BJ-12710	Seal o-ring	1
	BJ-12882A	BJ-12882A	Complete bearing pedestal	1
	BJ-12000A		Pump repair kit - 5 vane impeller Consists of all items market with •	1
	BJ-13000		Pump repair kit - 4 vane impeller Consists of all items market with •	1
	BJ-12999A	BJ-13999	Pump seal / O-ring kit Consists of all items marked with *	1

VUES EXPLOSÉES DES COMPOSANTES • PARTS BREAK DOWN

Filtre • Filter

MP-3244043, MP-3244044

MP-3244043	1 po - 50 mailles
MP-3244044	1 po - 100 mailles
MP-3244043	1" - 50 mesh
MP-3244044	1" - 100 mesh

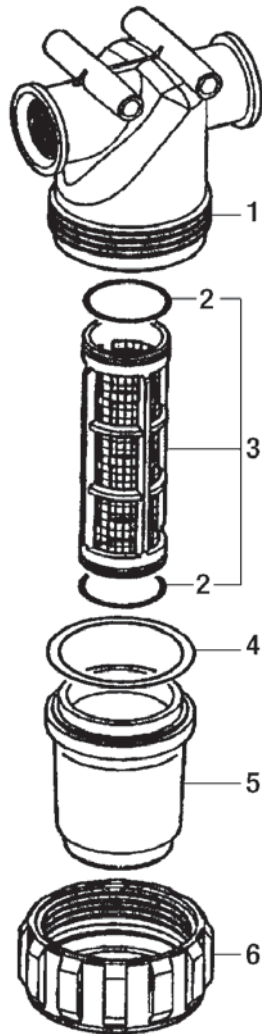

REF N°	DESCRIPTION	Q
1	MP-3244040010 Body	1
2	MP-322000050 O'ring see MP-G10051	2
3	MP-323002030 White cartridge, inox 32 mesh	1
	MP-323003030 Blue cartridge, inox 50 mesh	1
	MP-3230035030 Grey cartridge, inox 80 mesh	1
	MP-323004030 Red cartridge, inox 100 mesh	1
	MP-323006030 Orange cartridge, inox 150 mesh	1
4	MP-G11017 O'ring	1
5	MP-3224000020 Filter bowl	1
6	MP-3224000050 Nut	1

VUES EXPLOSÉES DES COMPOSANTES • PARTS BREAK DOWN

Enrouleur • Hose reel

HR-1500E

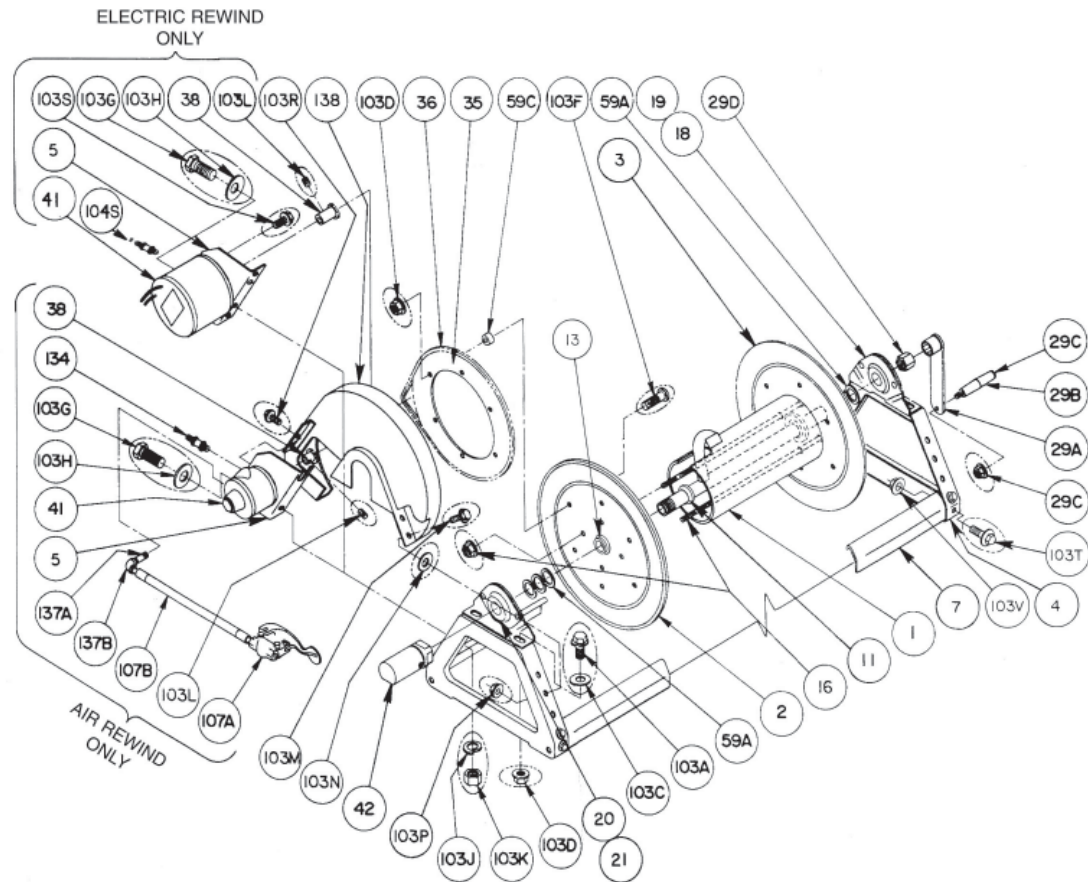

REF	N°	DESCRIPTION	Q	REF	N°	DESCRIPTION	Q
1	HR-99057112	Drum, 6" Alum. Tubing	1	103P	HR-99046000	1/4" - 20 Spinlock Nut	2
2	HR-99030516	16-1/2" Dia. E-Coated Disc (Front)	1	103R	HR-99041070	1/4" - 20 x 1/2" Self Tapping Screw	2
3	HR-99030516	16-1/2" Dia. E-Coated Disc (Back)	1	103T	HR-99041159	5/16"-18 x 5/8" Lg Hex Flanged Bolt	8
4	HR-99060011	Pressed Frame	2	103V	HR-99045602	5/16"-18 Top Lock Flanged Nut	8
7	HR-99076000	Footstock	2	138	HR-99570030	Plastic chain Guard	1
11A	HR-99010610	1/2" Welded Pipe Hub Assy w/ 1/2" FNPT Riser - Series 1500	1	OPTIONAL REMOVABLE REWIND CRANK			
11B	HR-99011050	1/2" Pipe Hub Assy Series C1500	1	29A	HR-99140051	Hand Crank	1
13	HR-99650040	Disc Washer	2	29B	HR-99140505	Hand Crank Handle	1
16	Specify Model	3/8" Carriage Bolt w/Nut	4	29C	HR-99140511	Hand Crank Handle Bolt w/Nut	1
18	HR-99021200	1/2" S.A. Bearing Complete (Back)	1	ELECTRIC			
19	HR-99021300	1/2" Brg. Insert (Back)	1	5	HR-99230006	Motor Mounting Plate-Electric Motor	1
20	HR-99021200	1/2" S.A. Bearing Complete (Front)	1	38	HR-99101119	11T35 Spkt. 1-3/4" LG	1
21	HR-99021300	1/2" Bearing Only	1	41	HR-99150042	Electric Motor (Specify Model)	1
29D	HR-99650013	1/2" Pipe Cap	1	103S	HR-99042159	5/16" - 18 x 5/8" Spinlock Bolt	4
35	HR-99101321	112T35 Disc Sprocket 13-3/8" Dia.	1	104S	GR-822151	Switch 12 V	1
36	HR-99120001	#35 Chain	1		GR-83280	Switch rubber cap	1
42	HR-99278551	1/2" 90 Degree FxF Superswivel Joint (Series 1500 only)	1	AIR			
59A	HR-99540020	1/2" Hub Spacer Washer	4	5	HR-99230013	Motor Mounting Plate #4 Air Motor	1
59B	HR-99650007	Tension Brake Spacer	1	38	HR-99101015	9T35 Spkt. 1-3/4" LG	1
59C	HR-99540015	GH-239 Sprocket Spacer	6	41	HR-99181122	4AM Gast Air Motor	1
103A	HR-99042201	3/8" - 16 x 3/4" Spin Lock Bolt	3	103S	HR-99042058	1/4" - 20 x 1/2" Spinlock Bolt	3
103C	HR-99540007	3/8" Flat Washer	4	107A	HR-99190004	#3420 Schrader Valve For #4 Air Mtr.	1
103D	HR-99046200	3/8" - 16 Spin Lock Nut	4	107B	HR-99190007	18" 1/4 x 1/4" Air Hose	1
103F	HR-99049202	3/8" - 16 x 1" Button HD Cap Screw	6	134	HR-99190006	Speed Control Muffler	1
103G	HR-99041402	1/2" - 13 x 1" Hex HD Cap Screw	2	137A	HR-99500012	1/4" x 1-1/2" Pipe Nipple	1
103H	HR-99540008	1/2" Flat Washer	2	137B	HR-99500013	1/4" 90 Degree Pipe Elbow	1
103J	HR-99540030	1/2" Split Lock Washer	2	HYDRAULIC			
103K	HR-99540036	1/2" - 13 Hex Nut	2	5	HR-99230013	Motor Mounting Plate - MTE Motor	1
103L	HR-99580002	1/4" - 20 Allen Set Screw w/Nylock Insert	2	38	HR-99101119	11T35 Spkt. 1-3/4" Long	1
103M	HR-99042058	1/4" - 20 x 1/2" Spinlock Bolt	2	41	HR-99182825	MTE Hydraulic Motor (Not Shown)	1
103N	HR-99540005	1/4" Flat Washer	2	103S	HR-99042103	5/16 - 18 x 1-1/4" Spinlock Bolt.	4
				103S	HR-99046100	5/16 - 18 Spinlock Nut (Not Shown)	4

VUES EXPLOSÉES DES COMPOSANTES • PARTS BREAK DOWN

Enrouleur • Hose reel

HR-1500M

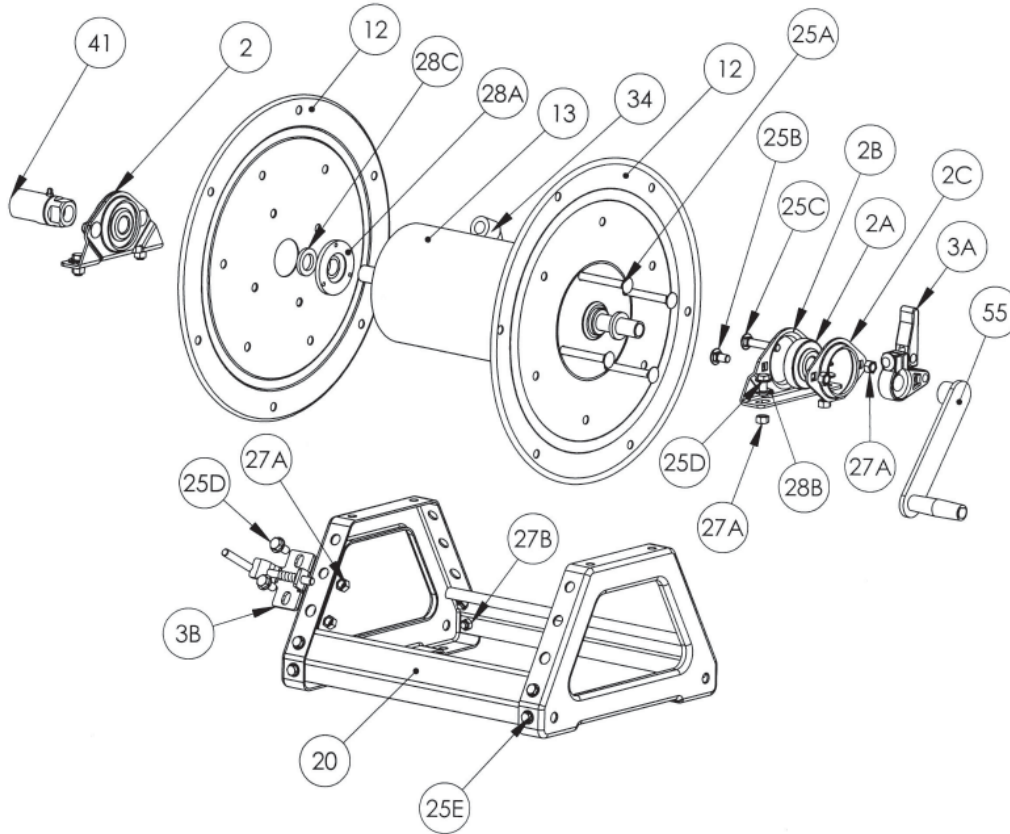

REF	N°	DESCRIPTION	Q
2	HR-99021200	1/2" Self Aligning Bearing Complete	2
2A	HR-99021300	1/2" Bearing Insert	2
2B	HR-99022900	Pillow Block (E-coated)	2
2C	HR-99022800	Bearing Holder (E-coated)	2
3A	HR-99470130	Cam Lever Drag Brake Kit (including hardware)	1
3B	HR-99650030	Pinlock, (Standard)	1
12	HR-99030516	Disc, 16-1/2" Diameter	2
13	HR-99057112	Drum, 6" Dia	1
20	HR-99081000	Complete Frame Assy. (fully assembled)	1
25A	Specify Model	3/8"-16 Carriage Bolt w/Nut	4
25B	HR-99040201	3/8"-16 x 3/4" Carriage Bolt	3
25C	HR-99040206	3/8"-16 x 2" Carriage Bolt	1
25D	HR-99042201	3/8"-16 x 3/4" Spinlock Bolt	6
25E	HR-99041159	5/16"-18 x 5/8" Lg Hex Flanged Bolt	8
27A	HR-99046200	3/8"-16 Spinlock Nut	14
27B	HR-99045602	5/16"-18 Top Lock Flanged Nut	8
28A	HR-99650040	Disc Washer	2
28B	HR-99540007	3/8" Flat Washer	4
28C	HR-99540020	1/2" Hub Spacer Washer	Varies
34	HR-99010610	1/2" Hub Assy., 1/2" FIPT Outlet Riser	1
41	HR-99278541	1/2" 90° FxF Super Swivel Joint	1
55	HR-99140021	Hand Crank Complete (includes hardware)	1
Not Shown	HR-99140505	Plastic Crank Handle Only w/ bolt & nut	1

VUES EXPLOSÉES DES COMPOSANTES • PARTS BREAK DOWN

Enrouleur • Hose reel

HR-1800E

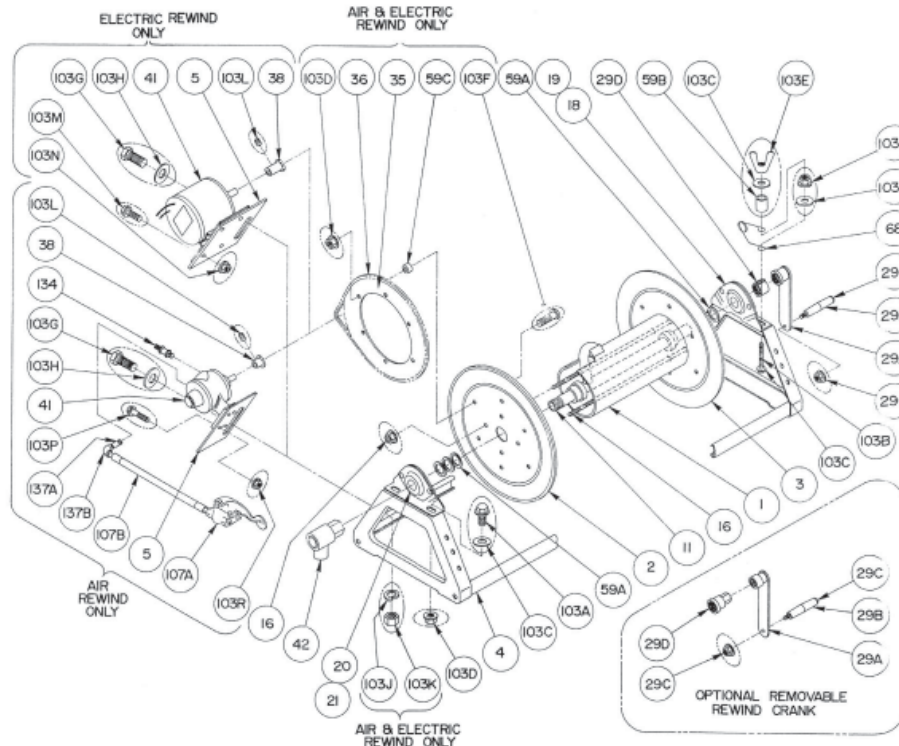

REF	NO	DESCRIPTION	Q	REF	NO	DESCRIPTION	Q
1	HR-99057112	Drum, 6" Alum. Tubing	1	103H	HR-99540008	1/2 Flat Washer	2
2	HR-99030516	16-1/2" Dia. E-Coated Disc (Front)	1	103J	HR-99540030	1/2 Split Lock Washer	2
3	HR-99030516	16-1/2" Dia. E-Coated Disc (Back)	1	103K	HR-99540036	1/2-13 Hex Nut	2
4	Specify Model	Frame Assy	1	103L	HR-99580002	1/4-20 Allen Set SCR w/Nylock Insert	2
11	HR-99012000	1" Welded Pipe Hub Assy	1	103M	HR-99042058	1/4-20 x 1/2" Spinlock Bolt	2
16	Specify Model	3/8" Carriage Bolt w/Nut	4	103N	HR-99540005	1/4" Flat Washer	2
18	HR-99021400	1" S.A. Brg. Complete (Back)	1	103P	HR-99046000	1/4-20 Spinlock Nut	2
19	HR-99021500	922 1" Brg. Insert (Back)	1	103R	HR-99041070	1/4-20 x 1/2" Self Tapping	2
20	HR-99021400	1" S.A. Brg. Complete (Front)	1	103S	HR-99042159	5/16" - 18 x 5/8" Spinlock Bolt	4
21	HR-99021500	922 1" Brg. Insert (Front)	1	138	Specify Model	Full Chain Guard	1
29A	HR-99140041	Hand Crank	1	5	HR-99230009	Motor Mounting Plate #4 Air Motor	1
29B	HR-99140505	Hand Crank Handle	1	29D	HR-99650014	1" Pipe Cap	1
29C	HR-99140511	Hand Crank Handle Bolt w/Nut	1	35	HR-99101321	112T35 Disc Sprocket 13-3/8" Dia.	1
42	HR-99298551	1" 90 Degree FxF Super Swivel	1	36	HR-99120001	#35 Chain	1
59A	HR-99540021	1" Hub Spacer Washer	4	38	HR-99101010	9T35 Spkt. 3/4" LG	1
59B	HR-99650007	Tension Brake Spacer 5/8 LG	1	41	HR-99181122	4AM Gast Air Motor	1
68	HR-99650002	Tension Spring	1	59C	HR-99540015	GH-239 Sprocket Spacer	6
103A	HR-99042201	3/8-16x3/4 Hex Serrated Washer HD	3	103D	HR-99046200	3/8-16 Serrated Locknut	6
103B	HR-99650011	3/8-16x3 Round HD Cap Screw	1	103F	HR-99049202	3/8-16 x 1 Button HD Cap Screw	6
103C	HR-99540007	3/8 Flat Washer	6	103G	HR-99041402	1/2-13 x 1 Hex HD Cap Screw	2
103D	HR-99046200	3/8-16 Serrated Locknut	4	103H	HR-99540008	1/2 Flat Washer	2
103E	HR-99650009	3/8-16 Wingnut	1	103J	HR-99540030	1/2 Split Lock Washer	2
29A	HR-99140051	Hand Crank Removable	1	103K	HR-99540036	1/2-13 Hex Nut	2
29B	HR-99140505	Hand Crank Handle	1	103L	HR-99580002	1/4-20 Allen Set SCR w/Nylock Insert	2
29C	HR-99140511	Hand Crank Handle Bolt w/Nut	1	103M	HR-99042058	1/4-20 x 1/2" Spinlock Bolt	2
29D	HR-99140701	1" Pipe Cap (Removable Crank)	1	103N	HR-99540005	1/4 Flat Washer	2
5	HR-99230006	Motor Mounting Plate Electric Motor	1	103P	HR-99046000	1/4-20 Spinlock Nut	2
29D	HR-99650014	1" Pipe Cap	1	103R	HR-99041070	1/4" - 20 x 1/2" Self Tapping	2
35	HR-99101321	112T35 Disc Sprocket 13-3/8" Dia.	1	103S	HR-99042058	1/4" - 20 x 1/2" Spinlock Bolt	3
36	HR-99120001	#35 Chain	1	107A	HR-99190004	#3420 Schrader Valve For #4 Air Mtr.	1
38	HR-99101119	11T35 Spkt. 1-3/4" LG	1	107B	HR-99190007	18" 1/4 x 1/4 Air Hose	1
41	Specify Model	Electric Motor	1	134	HR-99190006	Speed Control Muffler	1
59C	HR-99540015	GH-239 Sprocket Spacer	6	137A	HR-99500012	1/4" x 1-1/2" Pipe Nipple	1
103D	HR-99046200	3/8-16 Serrated Locknut	6	137B	HR-99500013	1/4 90 Degree Pipe Elbow	1
103F	HR-99049202	3/8-16 x 1 Button HD Cap Screw	6	138	Specify Model	Full Chain Guard	1
103G	HR-99041402	1/2-13 x 1 Hex HD Cap Screw	2				

VUES EXPLOSÉES DES COMPOSANTES • PARTS BREAK DOWN

Enrouleur • Hose reel

HR-1800M

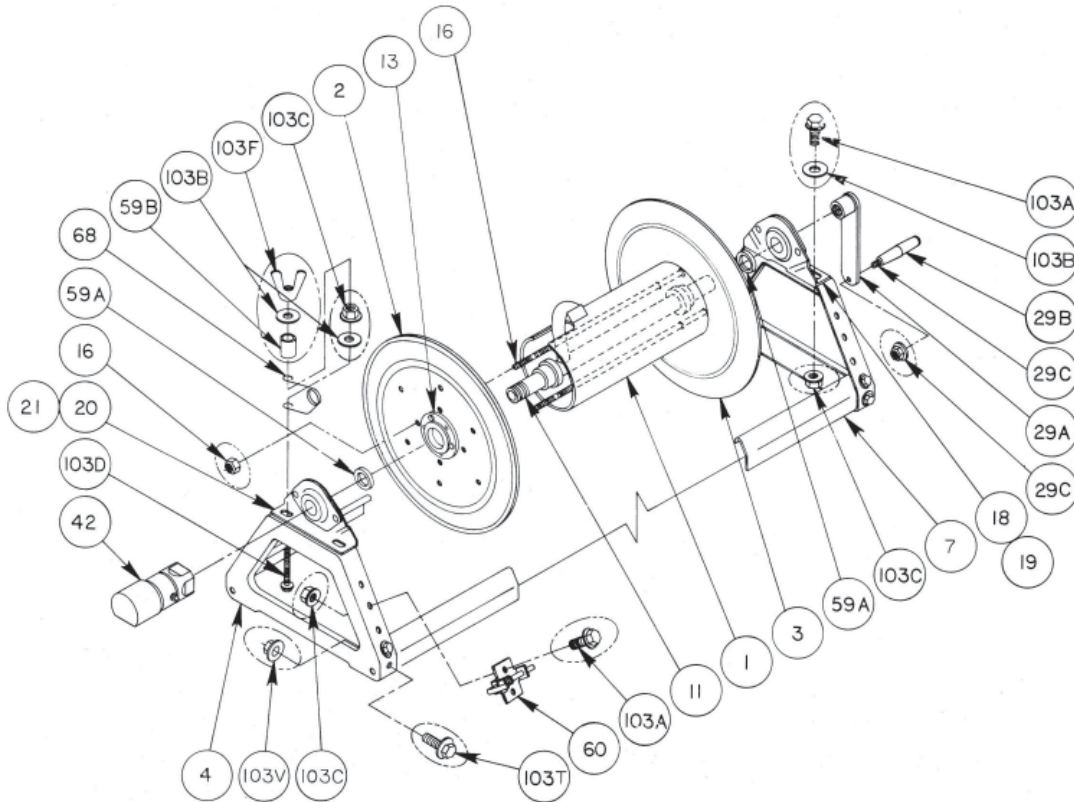

NOTE:
ITEMS CIRCLED ARE ENLARGED FOR CLARITY

REF	NO	DESCRIPTION	Q
1	HR-99057112	Drum, 6" Dia.	1
2	HR-99030516	Disc, 16-1/2" Dia. (Front)	1
3	HR-99030516	Disc, 16-1/2" Dia. (Back)	1
4	HR-99060011	Pressed Frame	1
7	HR-99076000	Footstock, GH-725	2
11	HR-99012000	1" Hub Assy., 3/4" FNPT Outlet Riser	1
13	HR-99650015	Disc Washer, EH-936	2
16	Specify Model	3/8" Carriage Bolt w/Nut	4
18	HR-99021400	1" Self Aligning Bearing Complete (Back)	1
19	HR-99021500	1" Bearing Insert (Back)	1
20	HR-99021400	1" Self Aligning Bearing Complete (Front)	1
21	HR-99021500	1" Bearing Insert (Front)	1
29A	HR-99140041	Hand Crank	1
29B	HR-99140505	Hand Crank Handle	1
29C	HR-99140511	Hand Crank Handle Bolt w/Nut	1
42	HR-99298551	1" 90 Deg. FxF Swivel Joint	1
59A	HR-99540021	1" Hub Spacer Washer	4
59B	HR-99650007	Tension Brake Spacer	1
60	HR-99650030	Pinlock	1
68	HR-99650002	Tension Brake Spring	1
103A	HR-99042201	3/8" - 16 x 3/4" Spinlock Bolt	5
103B	HR-99540007	3/8" Flat Washer	5
103C	HR-99046200	3/8" - 16 Spin Lock Nut	6
103D	HR-99650011	3/8" - 16 x 3" Round Head Cap Screw	1
103F	HR-99650009	3/8" - 16 Wing Nut	1
103T	HR-99041159	5/16" - 18 x 5/8" Lg Hex Flanged Bolt	8
103V	HR-99045602	5/16" - 18 Top Lock Flanged Nut	8

VUES EXPLOSÉES DES COMPOSANTES • PARTS BREAK DOWN

Pistolet • Gun

LE-007433

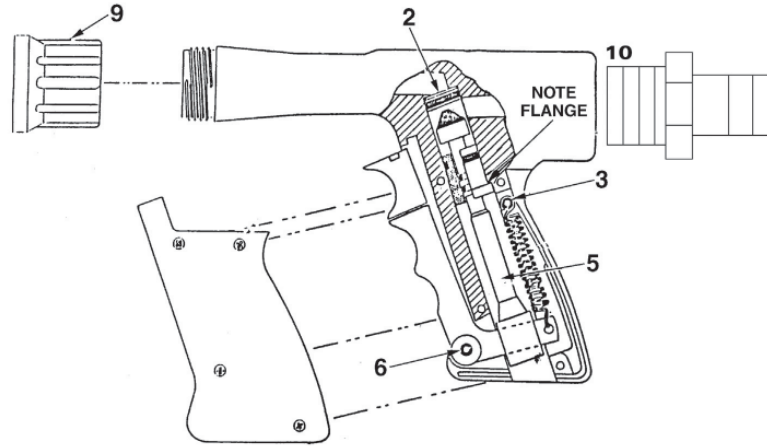

REF	NO	DESCRIPTION	Q
2	LE-007309	Valve seat insert w/O-ring	1
3	*	Spring pin, 1/8"	1
5	LE-007642	Internal assy	1
6	*	Trigger pin, 5/32"	1
9	JB-CP2567015NY	Nozzle (1.5 GPM, gray)	1
	JB-CP2567030NY	Nozzle (3 GPM, black)	1
	JB-CP2567040NY	Nozzle (4 GPM, std, red)	1
10	JB-2599034	Swivel 1/2" HB	1
	LE-007455	Valve seat tools	2

VUES EXPLOSÉES DES COMPOSANTES • PARTS BREAK DOWN

Pistolet • Gun

JB-256600

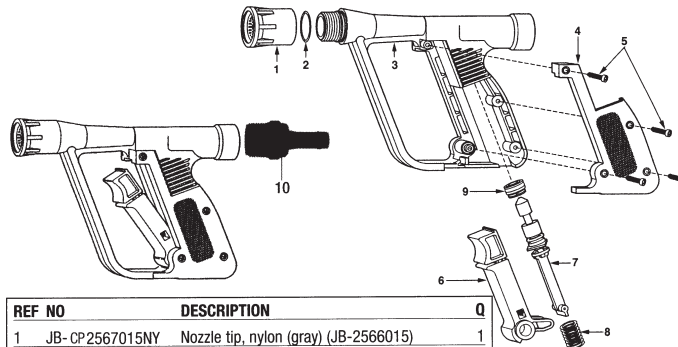

REF NO	DESCRIPTION	Q
1	JB-CP2567015NY Nozzle tip, nylon (gray) (JB-2566015)	1
	JB-CP2567030NYB Nozzle tip, nylon (black) (JB-2566030)	1
	JB-CP2567040NY Nozzle tip, nylon (red) (JB-2566040)	1
2*	JB-CP7717222VI O-ring, viton	1
3	JB-CP2566134NYB Body, nylon (black), 3/4"NPT (F) (JB-25660--)	1
4	JB-CP25662NYB Cover, nylon (black)	1
5	JB-CP25676916IZP #8 plastite screw, steel-zinc plated	4
6	JB-25675 Trigger sub-assy, nylon w/type 302 s.s. spring	1
7*	JB-25665 Stem sub-assy, nylon, polypropylene and viton	1
8	JB-CP25671302SS Spring, type 302 SS	1
9*	JB-25663 Seating sub-assy, polyprop. w/ viton O-ring	1
	JB-256600 Lawn spray gun (less nozzle tip), 3/4"NPT (F)	1
	JB-2566015 Lawn spray gun, 1.5 GPM	1
	JB-2566030 Lawn spray gun, 3.0 GPM	1
	JB-2566040 Lawn spray gun, 4.0 GPM	1
10	JB-2599034 Swivel	1
	JB-AB25660 Spare parts kit (incl. items marked with *)	

VUES EXPLOSÉES DES COMPOSANTES • PARTS BREAK DOWN

Pistolet • Gun

GG-JD9C

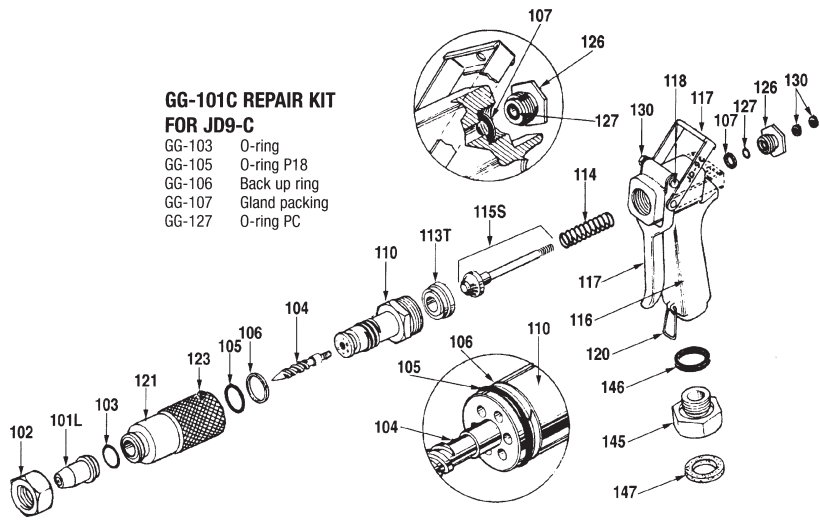

GG-101C REPAIR KIT FOR JD9-C
 GG-103 O-ring
 GG-105 O-ring P18
 GG-106 Back up ring
 GG-107 Gland packing
 GG-127 O-ring PC

HIGH PRESSURE SPRAY GUN MODEL JD9-C

NO	DESCRIPTION	Q
GG-101L	Nozzle tip & retainer	1
GG-102	Cap	1
GG-103	O-ring	1
GG-104	Whirler	1
GG-105	O-ring P18	1
GG-106	Back up ring	1
GG-107	Gland packing	1
GG-110	Adjuster body	1
GG-113T	Teflon valve seat	1
GG-114	Valve spring	1
GG-115S	Stainless steel valve	1
GG-116	Grip	1
GG-117	Trigger assembly	1
GG-118	Bolt	1
GG-120	Stopper clip	1
GG-121	Adjuster nut (barrel)	1
GG-123	Screw	1
GG-126	Gland	1
GG-127	O-ring P6	1
GG-130	Nut M6	3
GG-145	3/4 Garden coupling	1
GG-146	Packing	1
GG-147	Garden hose washer	1

Various tips and flooding nozzles are available for the JD9-C Spray Gun. The gun regularly comes with a GG-101L large tip which has been the main tip used. But other applications dictate gallons per minute needed, thus the other sizes. The Tips are all the same except for the size of the hole essentially in the hardened insert. The spray pattern from solid stream to fan will remain the same.

To assemble, unscrew the cap # GG-102, keeping the O-ring # GG-103 for reuse, and replace tip.

Two flooding (shower)nozzles are available, again the gallons per minute vary. The aluminum model costing less will not have the wear resistance of the stainless steel screen found in the GG-101FB brass nozzle. To assemble remove both the tip, cap and O-ring.

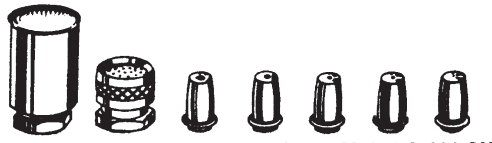

Flow rates approximate as flow dependent upon pressure.

Tips of chrome plated brass with stainless steel and hardened inserts.

Flooding (shower) nozzles : GG-101FA of aluminum with brass bushing. GG-101FB of brass with stainless steel screen.

NOZZLES APPROX. AND TIPS FLOW RATES

Part No.	Capacity - GPM
GG-101SX	.3 - 1
GG-101S	1 - 3
GG-101M	2 - 5
GG-101L	3 - 8
GG-101LX	10 - 19
GG-101FB	4 - 5
GG-101FA	5 - 7

VUES EXPLOSÉES DES COMPOSANTES • PARTS BREAK DOWN

Pistolet • Gun

JB-33810010, JB-33810011

REF NO	DESCRIPTION	Q
1	JB-9920232 Washer	1
2	JB-99200230 Inlet port	1
3	JB-99200193 Hand grip	1
4	JB-99200229 Tube	1
5	JB-99200231 Plug	1
6	JB-99203100 O-ring	1
7	JB-99200233 Spring	1
8	JB-9920240 Poppet	1
9	JB-99200129 Seat	1
10	JB-9920245B Body	1
11	JB-99202050 O-ring	1
12	JB-9920239 Plunger	1
13	JB-9920109 O-ring	1
14	JB-9920241 Guide	1
15	JB-9920246 Trigger	1
16	JB-9920245C Locking clip	1
17	JB-9920194 Pin	1
18	JB-99201751 Washer	1
19	JB-9920558768 Nut	1
20	JB-9920243 Rear barrel, Model-0010	1
	JB-9920413 Rear barrel, Model-0011	1
21	JB-9920244 Front barrel, Model-0010	1
	JB-9920412 Front barrel, Model-0011	1
22	JB-99200192 Front grip	1
23	JB-9920247 Bracket	1
24	JB-9920235 Regulator body, Model-0010	1
	JB-9920411 Regulator body, Model-0011	1
25	JB-99205931 Bolt	2
26	JB-99201751 Washer	2
27	JB-9920119 O-ring see JB-903835001	2
28	JB-9920237 Regulator	1
29	JB-9920238 Inner barrel, Model-0010	1
	JB-9920410 Inner barrel, Model-0011	1
30	JB-9920373 Outlet port, Model-0010	1
	JB-9920409 Outlet port, Model-0011	1
31	JB-9920183 Shroud, Model-0010	1
	JB-9920408 Shroud, Model-0011	1
32	JB-9920158 Nozzle retainer, Model-0010	1
	JB-9920407 Nozzle retainer, Model-0011	1
33	JB-9920115 O-ring	1
34	JB-9920124 O-ring	1
35	JB-3385---- Nozzles 2300,3000, 3500,4000,4500, 5000,5500,6000,7000	1

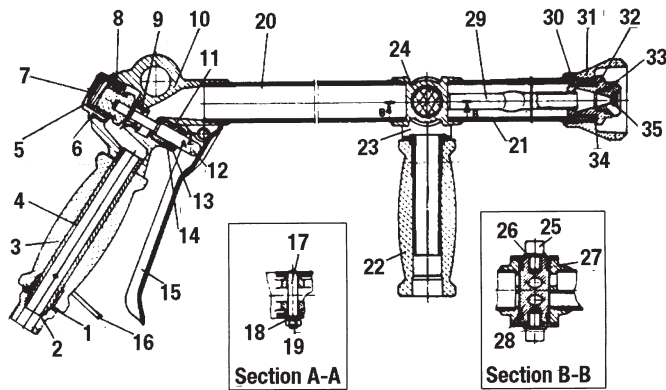

Repair kit No. JB-9920KIT10/11 consists of the following : No. JB-9920240 Poppet, JB-9920-129 Seat, JB-99203100 O-ring, JB-99202050 O-ring, JB-9920109 O-ring, JB-9920115 O-ring, JB-9920124 O-ring, and two JB-9920119 O-rings.

Hydro Part Number	Orifice Diameter in mm	Equivalent Nozzle #	Pressure in PSI** Performance	200 PSI** Setting		350 PSI** Setting		500 PSI** Setting		600 PSI** Setting		650 PSI** Setting		700 PSI** Setting		850 PSI** Setting	
				Cone	Straight	Cone	Straight	Cone	Straight	Cone	Straight	Cone	Straight	Cone	Straight	Cone	Straight
JB-33812300	2.3	14	Capacity in US/GPM *Max. throw in Feet	2.1	2.7	2.7	3.7	3.4	4.5	3.8	4.9	3.8	5	3.9	5.1	4.2	5.8
JB-33813000	3.0	25	Capacity in US GPM *Max. throw in Feet	2.9	4.6	3.7	6.3	4.8	7.5	5.2	8.4	5.3	8.5	5.4	8.6	6	9.6
JB-33813500	3.5	30	Capacity in US/GPM *Max. throw in Feet	5.8	6	7.9	8.2	9.6	9.9	10.7	11.1	11	11.3	11.2	11.6	12.4	12.8
JB-33814000	4.0	40	Capacity in US GPM *Max. throw in Feet	7	7.3	9.6	9.9	11.6	12	12.9	13.5	13.2	13.8	13.6	14.1	15	15.6
JB-33814500	4.5	50	Capacity in US GPM *Max throw in Feet	8.2	8.9	11.1	12	13.4	14.5	15	16.3	15.4	16.6	15.7	17	17.4	18.9
JB-33855000	5.0	70	Capacity in US GPM *Max throw in Feet	9.8	10.2	13.3	13.8	16	16.7	18	18.7	18.4	19.1	18.9	19.5	20.8	21.6
JB-33855500	5.5	80	Capacity in US GPM *Max. throw in Feet	10.7	11.5	14.4	15.6	17.4	18.8	19.6	21	20	21.5	20.4	22	22.6	24.4
JB-33856000	6.0	90	Capacity in US GPM *Max. throw in Feet	11.5	12.6	15.6	17.1	18.8	20.6	21	23.2	21.5	23.7	22	24.2	24.4	26.9
JB-33857000	7.0	100	Capacity in US GPM *Max. throw in Feet	21.1	43.7	25.3	54	30.7	60	35.6	66	35.6	67	36	68	36	74
				11.5	13.5	15.6	18.4	18.8	22.2	21	25	21.5	25.4	22	26	24.4	29
				21.1	46.8	25.3	57	30.7	63	37.4	70	37.4	71	38	72	38	77

*Figures shown are guidelines for vertical throw
**Pressures based on relief valve settings at straight throw



MS Gregson Inc.

4300, Vachon st.
Drummondville (Qc)
Canada J2B 6V4

Tel.: 819 474-1910

Fax: 819 474-5317

info@msgregson.com

www.msgregson.com