



- Manuel de l'utilisateur
- Manuel de pièces

- Operator's manual
- Parts manual

Pulvérisateur Utilitaire

Utility sprayer

Modèle ● Model

ST95K



MS Gregson Inc.
4300 Vachon
Drummondville
Qc, Canada, J2B 6V4

Tel. 819-474-1910
Fax 819-474-5317
info@msgregson.com
www.msgregson.com

LISTE DES RUBRIQUES

INTRODUCTION
GARANTIE
ÉTALONAGE POUR RAMPE (OPT.)
PRÉPARATION DE LA BOUILLIE
MISE EN MARCHÉ
MISE À L'ARRÊT
ENTRETIEN
REMISAGE POUR L'HIVER
ET / OU TRANSPORT PAR
TEMPS FROID (GEL)
DONNÉES TECHNIQUES
INCONVÉNIENTS ET REMÈDES
SCHÉMA D'ASSEMBLAGE
SCHÉMAS ET LISTES DES
COMPOSANTES
VUES EXPLOSÉES DES COMPOSANTES

LIST OF CONTENTS

INTRODUCTION
WARRANTY
CALIBRATION FOR BOOM (OPT.)
MIXTURE PREPARATION
STARTING PROCEDURE
STOPPING PROCEDURE
MAINTENANCE
WINTERIZATION AND / OR
COLD TEMPERATURE
TRANSPORTATION (FREEZING)
TECHNICAL DATA
TROUBLESHOOTING GUIDE
DRAWING ASSEMBLY
DRAWINGS AND
COMPONENTS LISTS
PARTS BREAK DOWN

INTRODUCTION

Merci d'avoir choisi un produit de qualité de MS Gregson Inc. Nous sommes heureux de vous compter parmi les propriétaires satisfaits de nos pulvérisateurs.

Plusieurs années de recherche ont mené au développement de cette série de modèles et seulement des pièces et matériaux de qualité sont utilisés. Chaque machine est soigneusement testée et inspectée avant de quitter notre usine pour vous assurer des années de performance.

Pour une performance continue, souvenez-vous que cette machine représente un important investissement de votre part mais, bien entretenue, elle vous retournera votre investissement plus d'une fois. Comme pour tous les équipements mécaniques, votre machine requiert une installation adéquate, une bonne opération et l'entretien spécifié dans ce manuel.

Veuillez lire ce manuel très attentivement et au complet avant d'installer et d'opérer votre machine. Examinez votre machine, ses accessoires et la caisse d'emballage pour noter tout dommage ou pièce manquante. Rapportez rapidement au transporteur toute réclamation pour perte ou dommage.

INTRODUCTION

Thank you for having selected a quality MS Gregson Inc. product. We are pleased to have you included among the many satisfied owners of our sprayers.

Years of research have brought into the development of these fine products and only top quality components and materials are used throughout. Every machine is carefully tested and inspected before leaving our plant to ensure you years of performance.

For a continuous performance, remember that this washer is a substantial investment for you, but properly cared and maintained it will return this investment many times. As with all mechanical equipment, your washer requires proper installation, proper operation and maintenance as specified in this manual.

Please read carefully the entire manual before installing and operating this machine. Examine machine, accessories and crate carefully for shipping damage or missing parts. Report promptly any shortages or damage claims to freight carrier.

POLITIQUE DE GARANTIES MS GREGSON

GARANTIE LIMITÉE

Les machines fabriqués par **MS Gregson Inc.** sont garantis, à l'acheteur initial au détail, comme étant exempts de vices de matériaux ou de fabrication pour les délais spécifiés ci-dessous. Les conditions d'utilisation normale conformes aux instructions décrites dans le manuel de l'utilisateur s'appliquent. Cette garantie limitée est sujette aux exclusions ci-dessous énumérées. Elle est calculée à partir de la date de livraison à l'acheteur initial et s'applique aux composantes originales seulement. Les pièces remplacées sous cette garantie jouissent du délai restant de la garantie pour les composantes correspondantes.

GARANTIE DE 1 AN SUR LES PIÈCES, 1 AN SUR LA MAIN-D'OEUVRE

Les composantes, excluant les accessoires mentionnés cidessous et les items d'entretien courant mentionnés ci-dessous, sont couvertes par une garantie de 1 an sur les pièces et la main-d'oeuvre.

GARANTIE OFFERTE PAR D'AUTRES MANUFACTURIERS

Les moteurs électriques ou à essence, batteries, pneus, jantes, contrôleur de taux ou autres items dont le fabricant offre directement une garantie, sont réparés dans un centre de service autorisé du fabricant correspondant. **MS Gregson Inc.** ne peut offrir de garantie sur ces items.

EXCLUSIONS DE LA GARANTIE

- Ajustements de routine et articles d'entretien courant tels que lubrifiants, courroies, boyaux, joints toriques, tamis de filtre, fusibles, systèmes d'étanchéité de pistolets.
- Réparations requises suite à une collision, un accident, un choc, un abus, des modifications apportées à l'équipement sans autorisation, une installation inadéquate, un mauvais entretien, une utilisation contraire aux directives fournies dans ce manuel ou au bon sens commun.
- Réparations requises suite au gel ou à l'exposition à des produits corrosifs.
- Réparation requises suite à des fluctuations de tension électrique d'alimentation.
- Réparations requises suite à une alimentation insuffisante en eau ou à une eau de mauvaise qualité.
- Dommage aux cultures dû à un mauvais calibrage ou usage de l'équipement.
- Dommage aux cultures ou déversement dû à un bris de composante et/ou un accident.
- Frais résultant de l'arrêt de l'unité durant une réparation ou pour toute autre raison.
- Frais de transport et/ou de déplacement.

EXÉCUTION DE RÉPARATION PENDANT LA PÉRIODE DE GARANTIE

Pour obtenir le service de garantie sur des pièces garanties par **MS Gregson Inc.** pendant la

MS GREGSON WARRANTY POLICY

LIMITED WARRANTY

The machines manufactured by **MS Gregson Inc.** are warranted, to the original purchaser, to be free from defects in materials and workmanship for the periods specified below. Normal use conditions, according to the instructions in the operator's manual, apply. This limited warranty is subject to the exclusions listed below, is calculated from the date of delivery to the original purchaser, and applies to the original components only. Parts replaced under this warranty will assume the remainder of the corresponding part's warranty period.

1 YEAR PARTS, 1 YEAR LABOUR WARRANTY

The components, excluding accessories listed below and normal wear items listed below, are warranted for 1 year on parts and labour.

WARRANTY PROVIDED BY OTHER MANUFACTURERS

Motors, engines, batteries, wheels, rims, rate controller or other items which are warranted by their respective manufacturers, are serviced through these manufacturer's local authorized service centres. **MS Gregson Inc.** cannot provide warranty on these items.

EXCLUSIONS OF WARRANTY

- Routine adjustments and normal maintenance items such as lubricants, belts, hoses, O-rings, filter screens, fuses, gun seal kits.
- Repairs required as a result of collision, accident, bumping, misuse, modifications made to the equipment without authorization, incorrect installation, lack of required maintenance, use contrary to the instructions included in this manual or to the common sense.
- Repairs required as a result of freezing or exposition to corrosive products.
- Repairs required as a result of voltage fluctuations of the electric supply.
- Repairs required as a result of insufficient water supply or poor quality water.
- Damage to crop due to wrong calibration or incorrect use of the equipment.
- Damage to crop or spill due to components failure and/or accident.
- Additional charge resulting from paralyzation and repair of the equipment.
- Transportation and/or travelling.

EXECUTION OF REPAIRS WITHIN THE WARRANTY PERIOD

In order to obtain warranty service on items warranted by **MS Gregson Inc.** within the warranty

période de garantie, vous devez montrer à votre concessionnaire une preuve d'achat de votre équipement. Si l'équipement est installé de façon permanente, les réparations seront effectuées sur place par le concessionnaire. Pour obtenir le service de garantie sur les composantes garanties par d'autres manufacturiers, votre concessionnaire peut vous aider à obtenir ces services dans un centre local de service autorisé. Le concessionnaire a la responsabilité d'effectuer les réparations couvertes pendant la durée de la garantie. Ces réparations se feront à l'atelier du concessionnaire pour les équipements mobiles ou chez le client au choix du concessionnaire ; le client au détail a la responsabilité d'apporter son équipement chez son concessionnaire. Les pièces changées sous garantie deviennent la propriété de **MS Gregson Inc.**

LIMITE DE LA RESPONSABILITÉ

La responsabilité de **MS Gregson Inc.** pour les dommages particuliers, accidentels ou consécutifs est expressément déniée. En aucun temps, la responsabilité de **MS Gregson Inc.** ne peut excéder le prix d'achat du produit en question. LA PRÉSENTE GARANTIE TIENT LIEU DE TOUTE AUTRE GARANTIE, EXPLICITE OU IMPLICITE, Y COMPRIS TOUTE GARANTIE IMPLICITE D'ADAPTATION POUR UNE UTILISATION PARTICULIÈRE. **MS Gregson Inc.** n'autorise aucune autre partie, incluant les concessionnaires **MS Gregson** autorisés, à faire toute représentation ou promesse au nom de **MS Gregson Inc.** ou à modifier les termes, conditions ou limitations d'aucune façon. Il est de la responsabilité de l'acheteur de s'assurer que l'installation et l'utilisation des produits **MS Gregson** respectent les codes locaux. Bien que **MS Gregson Inc.** tente de s'assurer que ses produits rencontrent les codes nationaux, elle ne peut être responsable de la façon dont le client choisit d'installer ou

period, you must show to your dealer a proof of purchase. If the equipment is permanently installed, repairs will be carried out on the spot by the dealer. For warranty service on components warranted by other manufacturers, your authorized **MS Gregson** dealer can help you obtain warranty service through these manufacturers' local authorized service centres. The dealer has the responsibility to carry out repairs within the warranty period. Repairs will be done at the dealer's repair-shop for mobile equipments (or at your site upon dealer choice); the purchaser has the responsibility to bring his equipment to his dealer's repair-shop. The parts changed under warranty become the property of **MS Gregson Inc.**

LIMITATION OF LIABILITY

MS Gregson Inc. liability for special, incidental, or consequential damages is expressly disclaimed. In no event shall **MS Gregson Inc.** liability exceed the purchase price of the product in question. THE WARRANTY CONTAINED HEREIN IS IN LIEU OF ALL OTHER WARRANTIES, EXPRESSED OR IMPLIED, INCLUDING ANY IMPLIED WARRANTY OF FITNESS FOR A PARTICULAR PURPOSE. **MS Gregson Inc.** does not authorize any other party, including authorized **MS Gregson** dealers, to make any representation or promise on behalf of **MS Gregson Inc.** or to modify the terms, conditions, or limitations in any way. It is the buyer's responsibility to ensure that the installation and use of **MS Gregson** products conforms to local codes. While **MS Gregson Inc.** attempts to assure that its products meet national codes, it cannot be responsible for how the customer chooses to use or install the product.



ÉTALONAGE POUR RAMPE (opt.)

Lire l'étiquette du produit et déterminer le taux d'application.

Déterminer la vitesse d'avancement (mph / km/h) avec le véhicule en mesurant une distance (TABLEAU 1).

Faire une marque sur le levier d'accélérateur pour avoir toujours la même vitesse.

Trouver le taux correspondant à la vitesse d'avancement (TABLEAU 2).

AVERTISSEMENT :

Il est préférable de faire un essai avec de l'eau.

Vérifier la quantité d'eau utilisée comparativement à la superficie pulvérisée et s'assurer du taux d'application afin d'éviter une sous ou une sur-application.

NOTE :

Pour assistance contacter les autorités agricoles locales ou votre concessionnaire de produit pour la calibration.

CALIBRATION FOR BOOM (opt.)

Read chemical product label and determine your target rate.

Determine your working speed (mph / km/h) with your vehicle by measuring distance (TABLE 1).

Make a mark on throttle position to always work at the same speed.

Find corresponding rate to your working speed (TABLE 2).

WARNING:

It is recommended to make a test with water.

Verify how much water you use compared to the treated area to be sure of spraying rate, avoiding all under or over application.

NOTE:

For assistance contact your agricultural local authorities or chemical dealer to help you on calibration.

tableau 1 / table 1

Vitesse MPH speed	Time required in sec. to travel a distance of / temps en secondes pour une distance de		
	100 pied/feet	200 pied/feet	300 pied/feet
0.5	136	273	409
0.75	90	182	272
1.0	68	136	205
1.5	45	91	136
2.0	34	68	102
2.5	27	55	82
3.0	23	45	68
3.5	19	39	58
4.0	17	34	51
Vitesse km/h speed	Time required in sec. to travel a distance of / temps en secondes pour une distance de		
	30 m	60 m	90 m
0.5	216	432	648
1.0	108	216	324
1.5	72	144	216
2.0	54	108	162
2.5	43	86	130
3.0	36	72	108
3.5	32	63	95
4.0	27	54	81
5.0	23	45	68
6.0	18	36	54

tableau 2 / table 2

Ce tableau est basé sur :

buse : TEEJET TFVP3
 Débit à une buse (max.): 2 l/min (0.53 gpm)
 Espacement : 91.44 cm (36'')

Formule:

$GPA = (5940 \times 0.53 \text{ gpm}) / (\text{MPH} \times 36'')$
 $l/ha = (60000 \times 2 \text{ l/min}) / (\text{km/h} \times 91.44 \text{ cm})$

This chart is based on:

nozzle : TEEJET TFVP3
 max. flow at nozzle : 2 l/min (0.53 gpm)
 spacing : 91.44 cm (36'')

Formula:

$GPA = (5940 \times 0.53 \text{ gpm}) / (\text{MPH} \times 36'')$
 $l/ha = (60000 \times 2 \text{ l/min}) / (\text{km/h} \times 91.44 \text{ cm})$

Vitesse d'avancement / working speed			Taux d'application / Application rate			
MPH	pi/min ft/min	km/h	Gal US / acre US GPA	Gal US/1000 pi ² US gal. / 1000 sq.ft.	l/ha ml/100 m ²	l / 100 m ²
0.5	44	0.80	174	506	1630	16.3
0.75	66	1.21	116	337	1087	10.9
1.0	88	1.61	87	253	815	8.2
1.5	132	2.41	58	169	543	5.4
2.0	176	3.22	44	126	408	4.1
2.5	220	4.02	35	101	326	3.3
3.0	264	4.83	29	84	272	2.7
3.5	308	5.63	25	72	233	2.3
4.0	352	6.44	22	63	204	2.0

PRÉPARATION DE LA BOUILLIE

Remplir le réservoir au 2/3 de la quantité requise pour le traitement à effectuer.

NOTE :

S'assurer d'avoir le temps requis pour compléter le traitement selon les conditions météorologiques. Ne jamais laisser de produit non-utilisé dans le réservoir et dans la plomberie de l'unité. Porter les équipements de protection requis pour la manutention des produits.

Verser directement les produits dans le réservoir.

NOTE :

Suivre les recommandations de dilution pour les produits de type granulaire ou en poudre. Toujours diluer avec de l'eau dans un autre contenant avant de verser dans le réservoir.

Entrer la buse du pistolet par le couvercle et actionner la gâchette pour agiter le produit. (Voir étape MISE EN MARCHÉ).

Ajouter de l'eau jusqu'à la quantité désirée. Agiter jusqu'à un mélange homogène. Retirer et rincer la lance avec de l'eau claire dans un réservoir. Fermer le couvercle.

MISE EN MARCHÉ

Installer l'unité au point d'attache du tracteur et brancher la connexion électrique à l'unité.

NOTE :

L'unité doit être au niveau ou avec une légère pente vers l'avant une fois installé à l'attache du tracteur.

Mettre les interrupteurs en position ON (l'interrupteur sur la pompe et sur l'auxiliaire).

Utiliser le pistolet pour bien mélanger le produit dans le réservoir, si l'unité a été entreposé un certain temps, se référer aux étiquettes de produit pour les taux de dilution (voir ÉTALONNAGE).

Utiliser le pistolet pour les endroits difficiles d'accès et en hauteur. Ajuster la buse pour obtenir la distance désirée.

Au besoin, ouvrir la vanne d'alimentation de la rampe. Un étalonnage doit être fait pour s'assurer de la dose à appliquer à chaque utilisation (voir ÉTALONNAGE). S'assurer que les deux buses ont le même débit à l'aide de contenants. Utiliser l'interrupteur ON/OFF pour contrôler la pulvérisation des buses de la rampe à partir du siège de l'opérateur. Avec un point de

MIXTURE PREPARATION

Fill the tank to 2/3 of needed volume for treatment to be made.

NOTE:

Make sure there is enough time to complete the application depending on weather conditions. Never leave unused product in the tank and in the unit plumbing. Wear protective equipment when handling chemicals.

Pour chemical in the tank.

NOTE:

Follow label instruction for dilution rate for granular and powder product. Always dilute with water in another jar before pouring it into the tank.

Insert handgun in the tank and press the gun trigger to agitate product in the tank. (See STARTING PROCEDURE).

Add water up to the desired water level. Agitate until satisfactory mix is obtained. Remove and rinse the wand with clear water in a tank. Close the lid

STARTING PROCEDURE

Attach unit tongue to the tractor and hook up the electrical connection to the unit pump.

NOTE:

The unit tank must be level or with slight slope forward when attached to tractor.

Turn ON the switches (switch on the pump and the auxiliary).

If the unit has been sitting for a while use the spray gun to have a good mixture in the tank, refer to product label for dilution rate (see CALIBRATION).

Use the gun for areas that are difficult to access and for high treatment. Adjust nozzle to obtain proper spray pattern.

If needed, open the boom supply valve. Calibration must be done before each use to be sure of proper rate (see CALIBRATION). Be sure to have same flow at both nozzles with calibration jar. Use ON/OFF switch to control spraying nozzle on the boom from operator's seat. With stakes, make runs with regular width to cover entire area to treat uniformly.

repère faire des passages de largeur régulière pour couvrir la superficie à traiter de façon uniforme.

MISE À L'ARRÊT

Mettre l'interrupteur en position OFF.

Fermer la vanne d'alimentation de la rampe.

IMPORTANT :

Rincer le réservoir de l'unité et la plomberie avec de l'eau claire après chaque utilisation (voir ENTRETIEN / REMISAGE).

ENTRETIEN / REMISAGE

Pompe :

Rincer avec de l'eau claire après chaque utilisation spécialement après une pulvérisation avec de l'engrais liquide, un insecticide ou un fongicide. Toujours porter un équipement de protection.

Filtre d'alimentation :

Vérifier et nettoyer régulièrement le filtre d'alimentation d'eau dans le réservoir.

Buses :

Vérifier et nettoyer régulièrement les buses pour éviter tout colmatage ou diminution de débit.

Nettoyage :

Nettoyer tous les filtres avant de commencer cette étape. Laver et rincer avec un produit neutralisant tous les équipements ayant été en contact direct ou indirect tel que l'embrun pour éviter tout risque de contamination lors de la manutention et l'entreposage. Consulter le fournisseur de produits sanitaire pour les produits de nettoyage et de neutralisation pour pulvérisateur. Nettoyer tous les filtres à nouveau.

Toujours nettoyer les équipements de pulvérisation dans un endroit bien aéré et non-cultivé et loin des sources d'eau potable. Consulter les instances agricoles locales pour les moyens à prendre et les règles à suivre pour éviter toute contamination des sources d'eau potable, enfants et animaux domestiques.

REMISAGE

Rincer et drainer le réservoir, la rampe, les tubes, les boyaux ainsi que la pompe.

Faire fonctionner l'unité en aspirant une solution d'antigel (prestone) de façon à ce qu'elle en soit complètement rempli

STOPPING PROCEDURE

Turn OFF the switch.

Close the boom supply valve.

IMPORTANT:

Rinse the unit tank and the plumbing with clear water after each use (see MAINTENANCE / STORAGE).

MAINTENANCE / STORAGE

Pump:

Rinse after each use with clear water especially if you use a liquid fertilizer, an insecticide or a fungicide. Always wear protective clothing.

Suction filter:

Regularly check and clean the suction water filter in the tank.

Nozzles:

Regularly check and clean nozzles to avoid plugging and lower flow rate.

Cleaning:

Clean all filters before starting this operation. Clean and wash with neutralizing product all the equipment that has been in direct or indirect contact with drift to avoid contamination in handling or storage. Consult your product suppliers to obtain cleaning and neutralizing product for sprayer. Clean all the filters again.

Always clean the sprayer equipment in a ventilated area and non-cultivated area away from water source. Contact local agricultural authorities for advice on disposal and laws to avoid contamination of water source, kids and pets.

STORAGE

Rinse and drain the tank, the boom, the tubes, the hoses and the pump.

Operate the system by sucking an anti-freeze (prestone) solution through the hoses and the pump. **NOTE: Do not use**

(boyaux et pompe). **NOTE : ne pas utiliser de liquide lave-vitre.**

Enlever la base et le tamis du filtre.

Enlever le cadran à pression et remiser au chaud (ne supporte pas le gel).

S'assurer qu'il ne reste plus de liquide dans les filtres.

Avant de mettre à nouveau l'unité en marche, bien vider et laver le réservoir, les boyaux et la pompe.

windshield washer fluid.

Take-off base and filter screen.

Take-off pressure gage and put it in a warm place (it does not support freezing).

Make sure that no liquid is left into the filters.

Before starting the unit again, be sure that the tank, hoses and pump are well emptied and washed.

DONNÉES TECHNIQUES ST95K	
Usage	Usage agricole
Débit	1.8 gal. US/min (6.8 l/min)
Pression maximum	3.1 bars 45 lb/po ²
Moteur courant	5.8 A
tension	12 Vcc
Pompe	Shurflow 8007543250
Boyaux / pistolet boyau	1/4 po x 26 pi
pistolet	60 lb/po ² , 0.6 à 1.7 l/min
Dimensions	30 x 23 x 38 po
(L x l x H) expedition	(76 x 58 x 97 cm)
Poids à vide	27 kg 60 lbs.
Capacité du réservoir	95 litres 25 gallons US

TECHNICAL DATA ST95K	
Use	Agricultural use
Flow rate	1.8 US gpm (6.8 l/min)
Maximum pressure	3.1 bars 45 psi
Engine current	5.8 A
voltage	12 Vdc
Pump	Shurflow 8007543250
Hose / gun hose	1/4 inch x 26 feet
gun	60 psi, 0.6 to 1.7 l/min
Dimensions	30" x 23" x 38"
(L x W x H) shipping	(76 x 58 x 97 cm)
Empty weight	27 kg 60 lbs.
Tank capacity	95 litres 25 US gallons

DONNÉES TECHNIQUES ST95K-150	
Usage	Usage agricole
Débit	1.5 gal. US/min (5.7 l/min)
Pression maximum	10.3 bars 150 lb/po ²
Moteur courant	12 A
tension	12 Vcc
Pompe	Shurflow 8030813239
Boyaux / pistolet boyau	1/4 po x 26 pi
pistolet	60 lb/po ² , 0.6 à 1.7 l/min
Dimensions	30 x 23 x 38 po
(L x l x H) expedition	(76 x 58 x 97 cm)
Poids à vide	27 kg 60 lbs.
Capacité du réservoir	95 litres 25 gallons US

TECHNICAL DATA ST95K-150	
Use	Agricultural use
Flow rate	1.5 US gpm (5.7 l/min)
Maximum pressure	10.3 bars 150 psi
Engine current	12 A
voltage	12 Vdc
Pump	Shurflow 8030813239
Hose / gun hose	1/4 inch x 26 feet
gun	60 psi, 0.6 to 1.7 l/min
Dimensions	30" x 23" x 38"
(L x W x H) shipping	(76 x 58 x 97 cm)
Empty weight	27 kg 60 lbs.
Tank capacity	95 litres 25 US gallons

INCONVÉNIENTS ET REMÈDES

TROUBLESHOOTING GUIDE

PROBLÈME	CAUSE	SOLUTION	FAULT	CAUSE	REMEDY
Le moteur ne fonctionne pas	Le moteur n'est pas alimenté en courant.	Brancher l'alimentation électrique.	The motor does not run.	There is no power supply.	Connect power cable.
	Le/les fusibles sont brûlés.	Remplacer.		One or both fuses are burnt out.	Replace.
	Le moteur n'est pas alimenté en courant.	Mettre l'interrupteur sur la pompe et l'interrupteur auxiliaire à la position ON.		There is no power supply.	Put the switch on the pump and the auxiliary switch in ON position.
	Le moteur est défectueux.	Remplacer.		The motor is defective.	Replace.
La pompe fonctionne, mais ne donne pas la pression maximum.	Les valves de la pompe sont usées ou sales.	Nettoyer ou remplacer.	The pump runs, but does not give maximum pressure.	The pump valves are worn or dirty.	Clean or replace.
	La pompe aspire de l'air.	Vérifier la tuyauterie de l'alimentation.		Pump is sucking air.	Check the suction line.
La pression n'est pas régulière.	Les valves de la pompe sont usées ou sales.	Nettoyer ou remplacer.	Fluctuating pressure.	The pump valves are worn or dirty.	Clean or replace.
	La pompe aspire de l'air.	Vérifier la tuyauterie.		Pump is sucking air.	Check the suction line.
	Les buses sont bouchées.	Nettoyer ou remplacer.		The nozzles are plugged.	Clean or replace.
	Les filtres sont bouchés.	Nettoyer ou remplacer.		The filters are plugged.	Clean or replace.
La pompe fonctionne mais le liquide ne coule pas aux buses.	Le filtre d'aspiration est bouché.	Nettoyer ou remplacer.	The pump is working but no liquid comes out from the nozzles.	The suction filter is plugged.	Clean or replace.
	Les buses sont bouchées.	Nettoyer ou remplacer.		The nozzles are plugged.	Clean or replace.
	Les filtres sont bouchés.	Nettoyer ou remplacer.		The filters are plugged.	Clean or replace.
Traitement non-uniforme, débit différent aux buses de rampe	Les buses sont bouchées.	Nettoyer ou remplacer.	Uneven spray, different flows at the boom nozzles.	The nozzles are plugged.	Clean or replace.
	Les buses sont usées.	Remplacer.		The nozzles are worn.	Replace.
Mauvaise dose d'application	Mauvais étalonnage.	Refaire étape d'étalonnage ou consulter le concessionnaire pour assistance.	Wrong spray rate.	Wrong calibration.	Redo the calibration step or consult your local dealer for assistance.
Fuite de liquide par la buse du fusil	Le siège du fusil n'est pas étanche.	Nettoyer ou remplacer.	Liquid leakage at the gun spray nozzle.	The seat is not tight.	Clean or replace.

#	REF.	Q.	L"
1	LV-12K3150	1	16 "
2	LV-38K3150	1	224 "

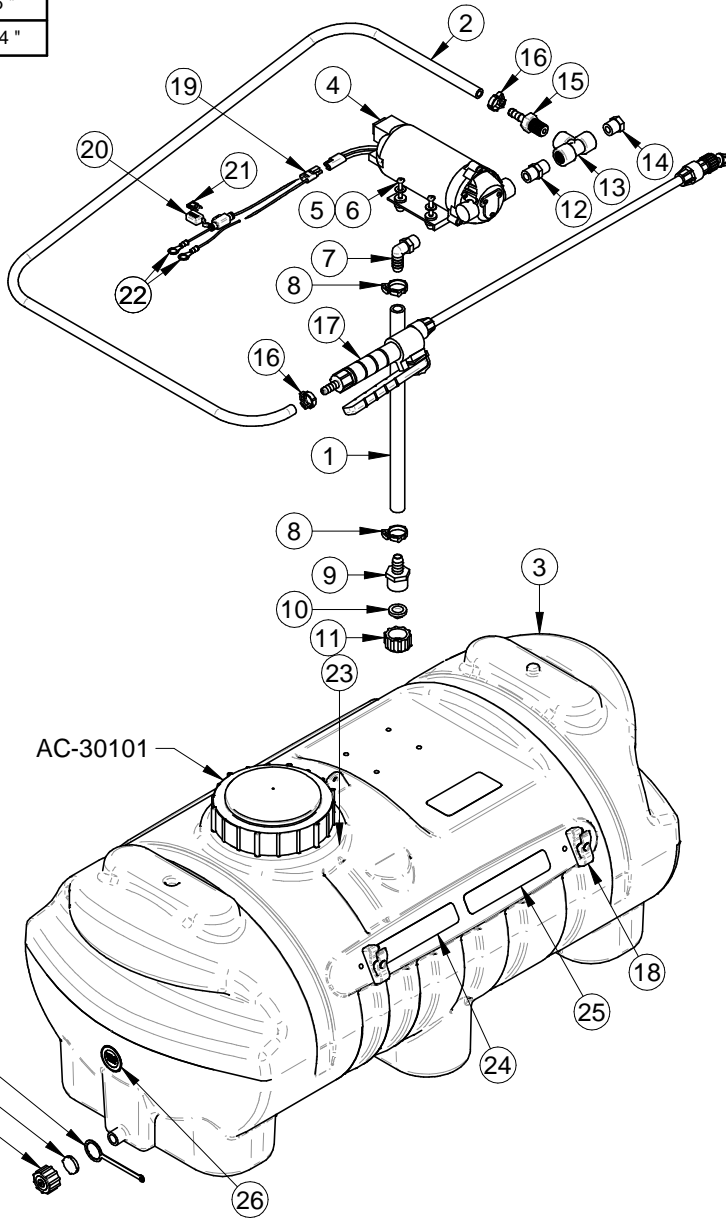

#	REF.	Q.
3	AC-SB25WPSPR	1
4	SH-8007543250	1
5	BT-FW316	4
6	BT-10241RS	4
7	JB-EL3812NY40	1
8	SN-078008	2
9	JB-IHB0004NY40	1
10	JB-38000035	1
11	MP-3B34G	1
12	JB-M3800NY40	1
13	JB-TT38NY	1
14	JB-VMM0003NY40	1
15	JB-IMB0303NY40	1
16	SN-078005	2
17	JB-5080021AL406	1
18	AC-12200	1
19	AU-FIL2B8	1
20	AU-666257	1
21	AU-MIN10	1
22	DO-761022	2
23*	AU-PNS3-G	1
24	AU-DECAVER3	1
25	AU-DECAVER7	1
26	AU-DECMSLOGOB-G	2
27*	AU-BL371918	1
28*	A120-0019	1
29*	AU-SAZL46	1
30*	AU-L8400M	4

AC-19009
AC-10960
AC-19010

REV 6 : AU-666257 était AU-11612 et AU-MIN10 était AU-ACT10 2024-01-17 FulhamE
REV 5 : LV-38K3150 était 240" 12/07/2018 P.Allard

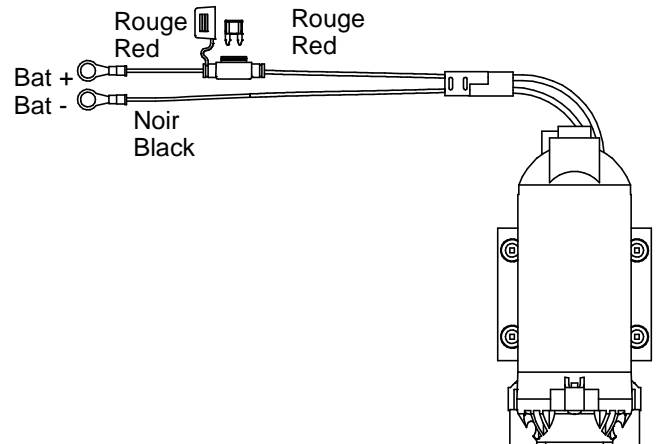
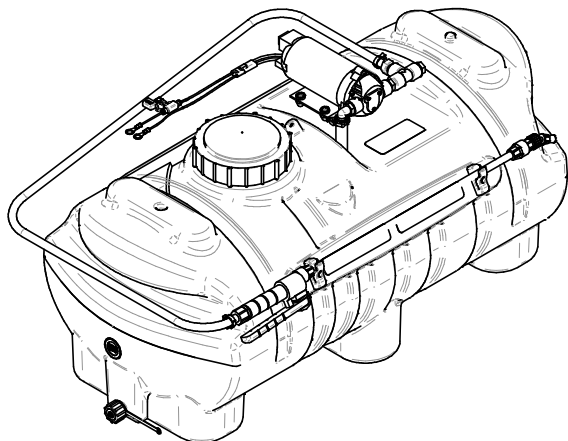

REF	NO	DESCRIPTION	Q
3B	SH-3018900	No control plate	1
	SH-121001	Screw	3
4	SH-9437900	Upper housing	1
8	SH-1116801	Motor with electrical package	1
9	SH-9439107	Valve assembly	1
10	SH-9438532	Solid diaphragm drive assembly	1
11	SH-8007543SW	Switch	1
12	SH-8471200	Case assembly	1

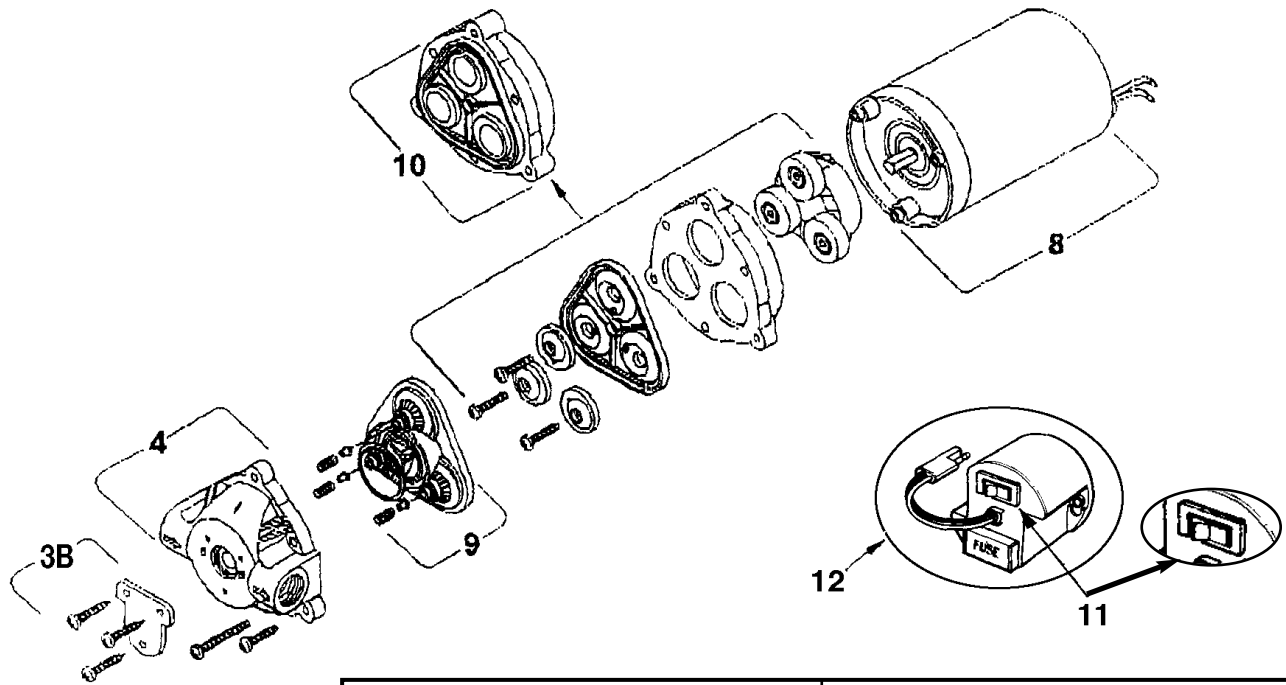

POMPE COMPLÈTE / PUMP ASSEMBLY		POMPE COMPLÈTE / PUMP ASSEMBLY	
Débit	1.8 gal US/min - 6.8 l/min	Membrane	Santoprene
Flow rate	1.8 US GPM - 6.8 l/min	Diaphragm	Santoprene
Pression maximale	.45 lb/po ²	Valves	Viton
Maximum pressure	.45 PSI	Valves	Viton
Contrôle	"By-pass" interne	Entrée-sortie	.3/8" FNPT
Control	Internal by-pass	Ports	.3/8" FNPT
Cam	3.0 degrés	Température de liquide	170°F / 77°C max.
Cam	3.0 degrees	Liquid temperature	170°F / 77°C max.
Commutateur de pression	non	Auto-amorçage	jusqu'à 11' d'élévation
Pressure switch	none	Self-priming	up to 11' vertical
Volt	.12V DC	Pression max. d'entrée	.30 lb/po ²
Volt	.12V DC	Max. inlet pressure	.30 PSI
Ampérage	.5.6 amp	Usage	Continu
Amperage	.5.6 amp	Duty cycle	Continuous
Corps de pompe	.Polypropylène	Poids	.4.6 lb (2.1 kg)
Pump housing	.Polypropylene	Weight	.4.6 lb (2.1 kg)

#	REF.	Q.	L"
1	LV-12K3150	2	16 "
2	LV-38K3150	1	240 "
3	AU-TUBERET38	1	6 "

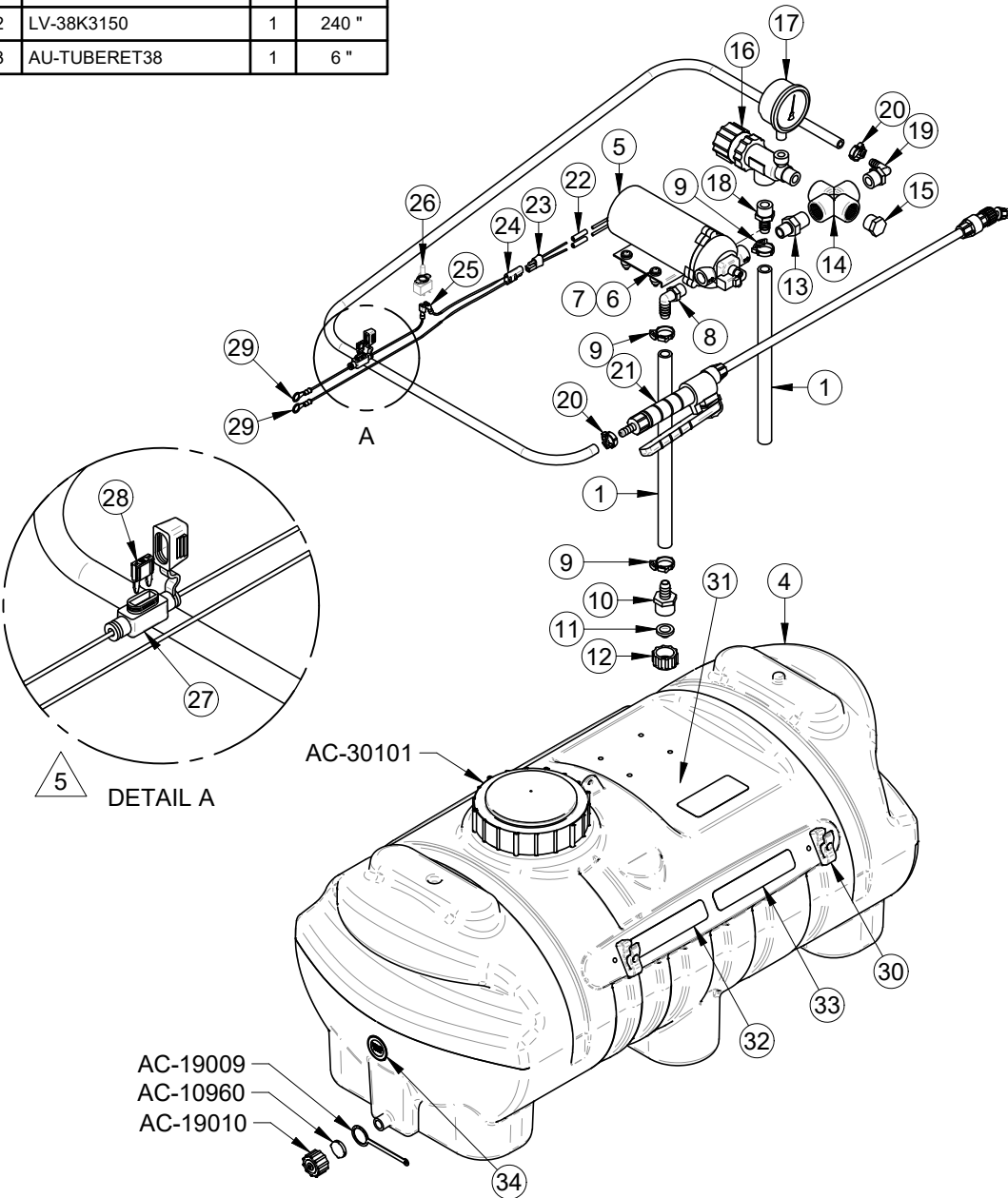

#	REF.	Q.
4	AC-SB25WPSPR	1
5	SH-8030813239	1
6	BT-10241RS	4
7	BT-FW316	4
8	JB-EL3812NY40	1
9	SN-078008	3
10	JB-IHB0004NY40	1
11	JB-38000035	1
12	MP-3B34G	1
13	JB-RMM0304NY	1
14	BJ-CR050	1
15	JB-VMM0004NY40	1
16	JB-2312012PP	1
17	JB-025FF00200	1
18	JB-IMB0404NY40	1
19	JB-EL1238NY40	1
20	SN-078005	2
21	JB-5080021AL406	1
22	DO-761232	2
23	AU-10199	1
24	AU-FIL2B8	1
25	DO-761357	2
26	AU-PPCA20173	1
27	AU-666257	1
28	AU-MIN10	1
29	DO-761022	2
30	AC-12200	1
31*	AU-PNS3-G	1
32	AU-DECAVER3	1
33	AU-DECAVER7	1
34	AU-DECMSLOGOB-G	2
35*	AU-L8400M	4
36*	AU-SAZL46	1
37*	A120-0019	1
38*	AU-BL371918	1

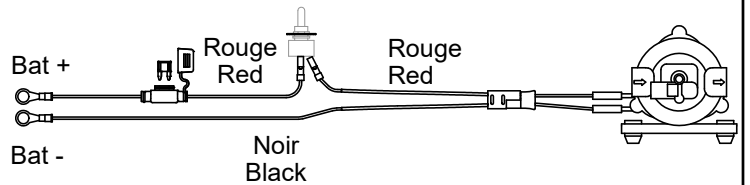
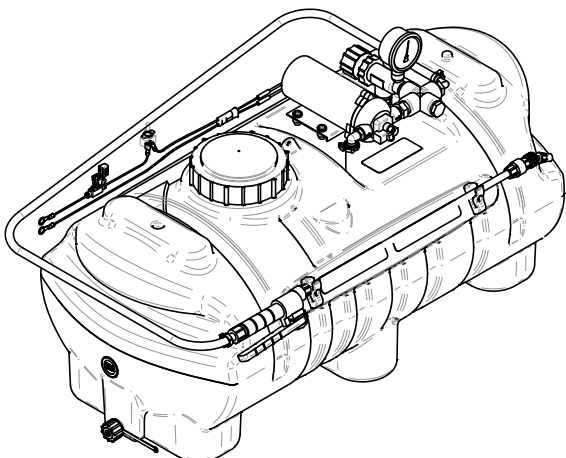

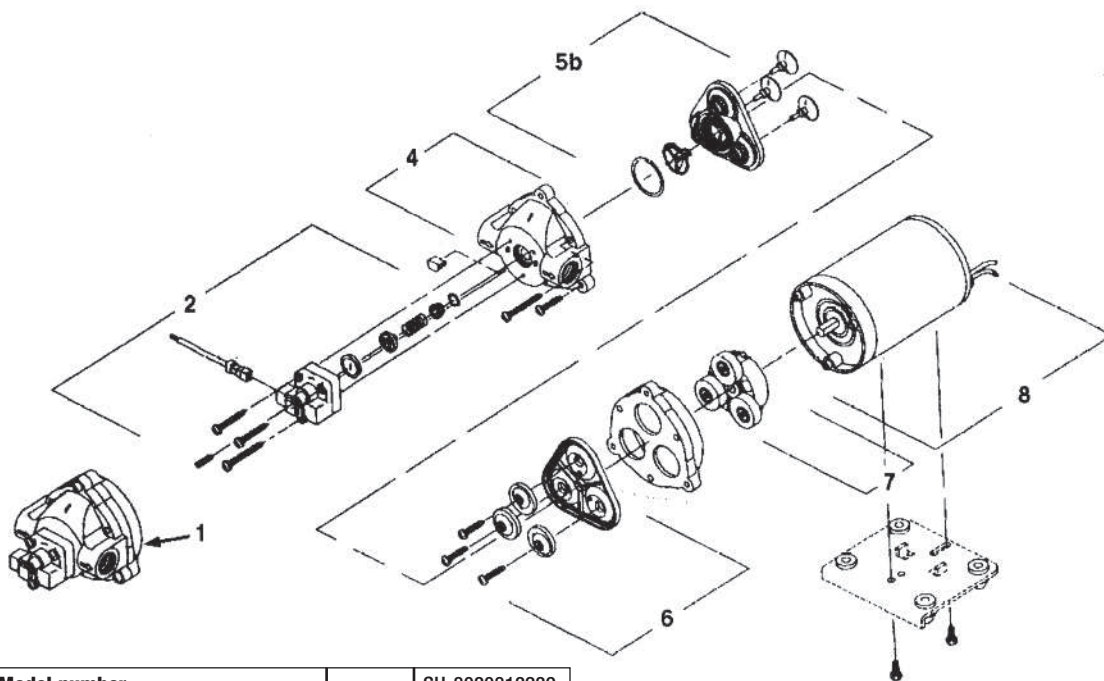

Model number		SH-8030813239
Complete pump assembly	1	N/A
Switch assembly	2	SH-8437520
Upper housing	4	SH-9437901
Bypass/ non bypass valve assembly	5	SH-9439015
Diaphragm assembly	6	SH-9438532
Drive/ impeller assembly	7	N/A
Motor	8	SH-1122700

POMPE COMPLÈTE / PUMP ASSEMBLY	POMPE COMPLÈTE / PUMP ASSEMBLY
Débit1.5 gal US/min - 5.5 l/min	ValvesViton
Flow rate1.5 US GPM - 5.5 l/min	ValvesViton
Pression maximale150 lb/po ²	Entrée-sortie3/8" FNPT
Maximum pressure150 PSI	Ports3/8" FNPT
ContrôleCommutateur de pression	Température de liquide170°F / 77°C max.
ControlPressure switch	Liquid temperature170°F / 77°C max.
Came3.0 degrés	Auto-amorçagejusqu'à 8' d'élévation
Cam3.0 degrees	Self-primingUp to 8' vertical
Volt12V DC	Pression max. d'entrée30 lb/po ²
Volt12V DC	Max. inlet pressure30 PSI
Ampérage12 amp	UsageContinu
Amperage12 amp	Duty cycleContinuous
Corps de pompePolypropylène	Poids4.2 lb (1.9 kg)
Pump housingPolypropylene	Weight4.2 lb (1.9 kg)
MembraneSantoprene	
DiaphragmSantoprene	

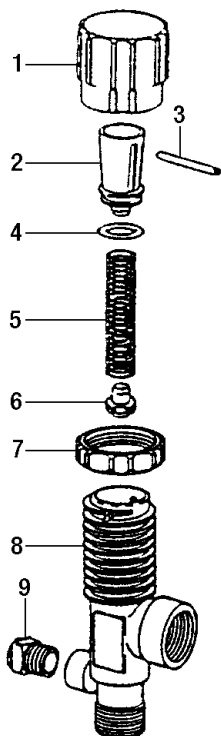
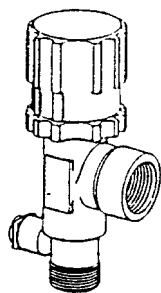

REF NO	DESCRIPTION	Q
1	JB-CP23122NY Adjusting cap, nylon (gray)	1
2	JB-CP23124PPB Spring retainer, polypropylene (black)	1
3	JB-CP23126302SS Retaining pin, type 302 s. steel	1
4	JB-CP771715EPR O-ring, EPDM rubber (std)	1
	JB-CP771715VI O-ring, Viton (opt.)	1
5	JB-CP23127302SS Spring, type 302 s. steel (std)	1
	JB-CP23127316SS Spring, type 316 s. steel (opt.)	1
6	JB-CP23125PPB Guide seat, polypropylene (black)	1
7	JB-CP23123PP Lock ring, polypropylene (gray)	1
8	JB-CP231281PPB Body, polypropylene (black) / JB-2312012PP	1
	JB-CP231211PPB Body, polypropylene (black) / JB-231203400	1
9	JB-840014NY 1/4 pipe plug, nylon	1

#	REF.	Q.	L"
1	LV-38K3150	1	60"

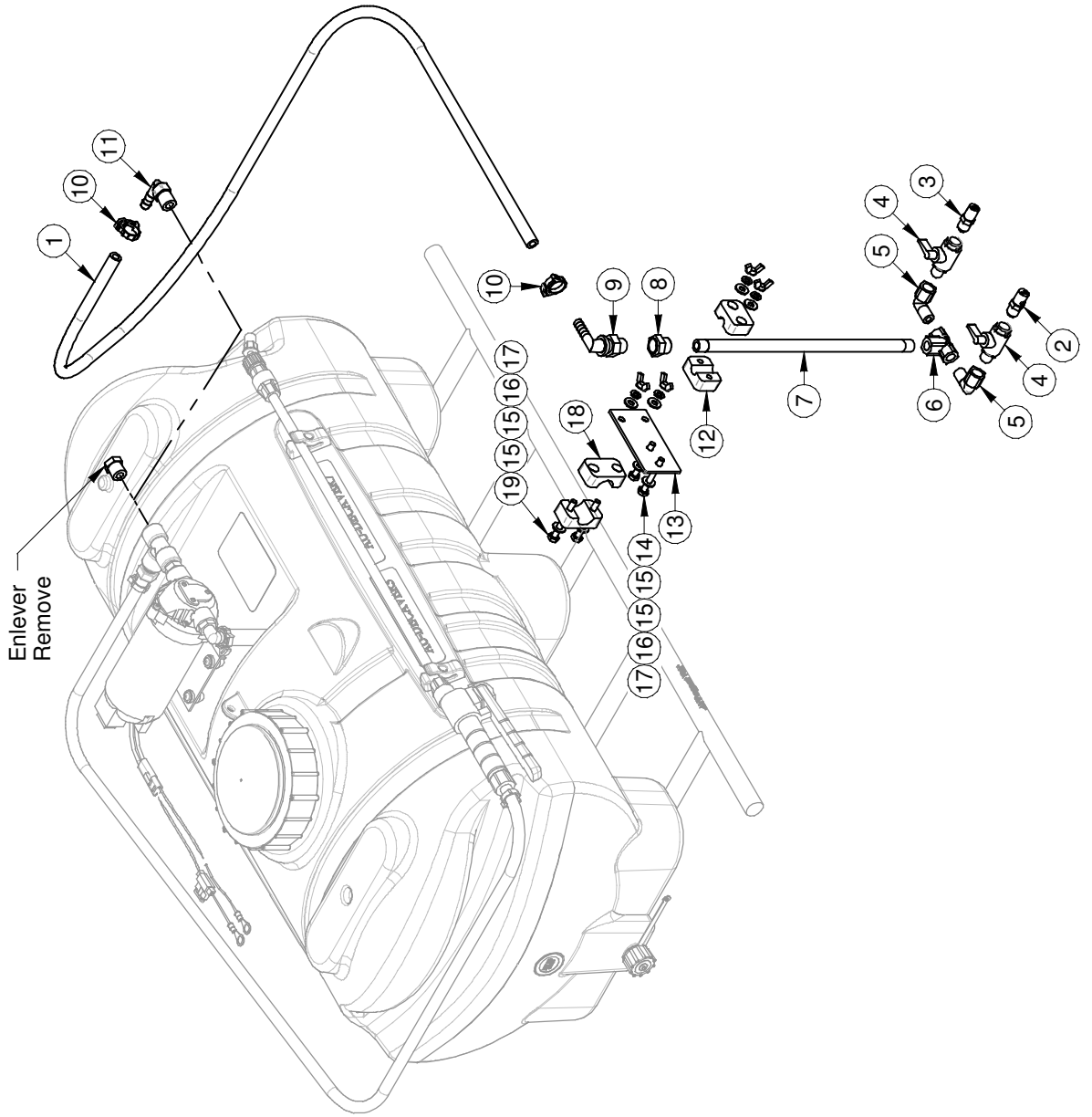

#	REF.	Q.
2	JB-14XP10LVP	1
3	JB-14XP10RVP	1
4	BJ-LV025MTV	2
5	JB-SE14NY40	2
6	JB-TT14NY40	1
7	C800-0005	1
8	JB-467614NY	1
9	JB-8121NY406	1
9*	AU-L5300M	6
10	SN-078006	2
11	JB-EL3838NY	1
12	AU-2137PP	1
13	C800-0006	1
14	BT-142	2
15	BT-FW14	8
16	BT-LW14	4
17	SN-WN6	4
18	AU-3213PP	1
19	BT-14214	2

#	REF.	Q.	L"
1	LV-12K3150	1	240"

#	REF.	Q.
2	JB-8120NY540	3
3	JB-8121NY540	2
4	JB-8079PP50	5
5	JB-TP11003VP	3
6	JB-OC03	2
7	JB-8027NY	5
8	DA-SHAS6	16
9	JB-AA111SQ1	5
10	JB-T12NY40	1
11	JB-IMB0304BR	3
12	JB-3FPS	1
13	JB-3FBP	1
14	JB-IMB0404BR	2
15	JB-050FFBT	1

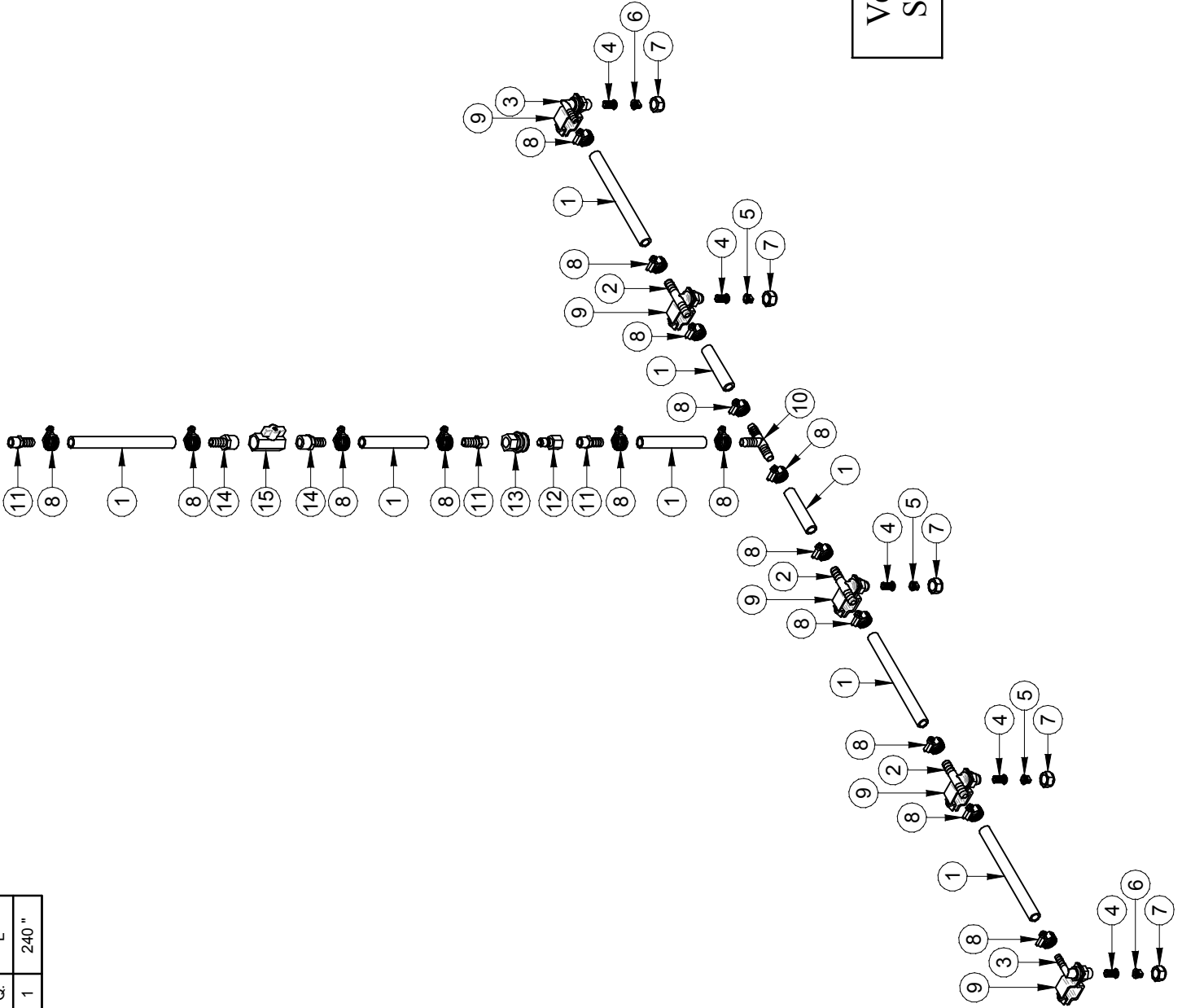

Vendu non assemblé
Sold not assembled



TeeJet® Off-Center Flat Spray Tips — Smaller Capacities

TeeJet Off-Center spray tips are commonly installed in double and single swivel nozzle bodies. Because these bodies are adjustable for angular position, a wide spray swath is easily obtained.



See page 59 for swivels and hose drops.

How to order:

Specify tip number and material.

Example: OC-02 Brass



Icon	bar	CAPACITY ONE NOZZLE IN l/min	HEIGHT = 45 cm				HEIGHT = 60 cm					
			"W" cm	l/ha				"W" cm	l/ha			
				4 km/h	6 km/h	8 km/h	10 km/h		4 km/h	6 km/h	8 km/h	10 km/h
OC-01 (100)	2.0	0.32	147	32.7	21.8	16.3	13.1	165	29.1	19.4	14.5	11.6
	3.0	0.39	152	38.5	25.7	19.2	15.4	170	34.4	22.9	17.2	13.8
	4.0	0.45	157	43.0	28.7	21.5	17.2	175	38.6	25.7	19.3	15.4
OC-02 (50)	2.0	0.65	172	56.7	37.8	28.3	22.7	190	51.3	34.2	25.7	20.5
	3.0	0.79	177	66.9	44.6	33.5	26.8	195	60.8	40.5	30.4	24.3
	4.0	0.91	182	75.0	50.0	37.5	30.0	198	68.9	46.0	34.5	27.6
OC-03 (50)	2.0	0.96	195	73.8	49.2	36.9	29.5	203	70.9	47.3	35.5	28.4
	3.0	1.18	203	87.2	58.1	43.6	34.9	210	84.3	56.2	42.1	33.7
	4.0	1.36	208	98.1	65.4	49.0	39.2	215	94.9	63.3	47.4	38.0
OC-04 (50)	2.0	1.29	231	83.8	55.8	41.9	33.5	236	82.0	54.7	41.0	32.8
	3.0	1.58	236	100	66.9	50.2	40.2	238	99.6	66.4	49.8	39.8
	4.0	1.82	238	115	76.5	57.4	45.9	241	113	75.5	56.6	45.3
OC-06 (50)	2.0	1.94	251	116	77.3	58.0	46.4	274	106	70.8	53.1	42.5
	3.0	2.37	256	139	92.6	69.4	55.5	279	127	84.9	63.7	51.0
	4.0	2.74	259	159	106	79.3	63.5	281	146	97.5	73.1	58.5
OC-08 (50)	2.0	2.58	254	152	102	76.2	60.9	279	139	92.5	69.4	55.5
	3.0	3.16	259	183	122	91.5	73.2	284	167	111	83.5	66.8
	4.0	3.65	264	207	138	104	83.0	287	191	127	95.4	76.3
OC-12	2.0	3.87	259	224	149	112	89.7	287	202	135	101	80.9
	3.0	4.74	264	269	180	135	108	292	243	162	122	97.4
	4.0	5.47	266	308	206	154	123	294	279	186	140	112
OC-16	2.0	5.16	335	231	154	116	92.4	360	215	143	108	86.0
	3.0	6.32	350	271	181	135	108	370	256	171	128	102
	4.0	7.30	363	302	201	151	121	375	292	195	146	117

Note: Always double check your application rates. See pages 149-163 for useful formulas and information.

Icon	PSI	CAPACITY ONE NOZZLE IN GPM	HEIGHT = 18"				HEIGHT = 24"					
			"W" IN INCHES	GPA				"W" IN INCHES	GPA			
				3 MPH	4 MPH	5 MPH	6 MPH		3 MPH	4 MPH	5 MPH	6 MPH
OC-01 (100)	30	0.087	58	3.0	2.2	1.8	1.5	65	2.7	2.0	1.6	1.3
	40	0.10	60	3.3	2.5	2.0	1.7	67	3.0	2.2	1.8	1.5
	60	0.12	62	3.8	2.9	2.3	1.9	69	3.4	2.6	2.1	1.7
OC-02 (50)	30	0.17	68	5.0	3.7	3.0	2.5	75	4.5	3.4	2.7	2.2
	40	0.20	70	5.7	4.2	3.4	2.8	77	5.1	3.9	3.1	2.6
	60	0.24	72	6.6	5.0	4.0	3.3	78	6.1	4.6	3.7	3.0
OC-03 (50)	30	0.26	77	6.7	5.0	4.0	3.3	80	6.4	4.8	3.9	3.2
	40	0.30	80	7.4	5.6	4.5	3.7	83	7.2	5.4	4.3	3.6
	60	0.37	82	8.9	6.7	5.4	4.5	85	8.6	6.5	5.2	4.3
OC-04 (50)	30	0.35	91	7.6	5.7	4.6	3.8	93	7.5	5.6	4.5	3.7
	40	0.40	93	8.5	6.4	5.1	4.3	94	8.4	6.3	5.1	4.2
	60	0.49	94	10.3	7.7	6.2	5.2	95	10.2	7.7	6.1	5.1
OC-06 (50)	30	0.52	99	10.4	7.8	6.2	5.2	108	9.5	7.2	5.7	4.8
	40	0.60	101	11.8	8.8	7.1	5.9	110	10.8	8.1	6.5	5.4
	60	0.73	102	14.2	10.6	8.5	7.1	111	13.0	9.8	7.8	6.5
OC-08 (50)	30	0.69	100	13.7	10.2	8.2	6.8	110	12.4	9.3	7.5	6.2
	40	0.80	102	15.5	11.6	9.3	7.8	112	14.1	10.6	8.5	7.1
	60	0.98	104	18.7	14.0	11.2	9.3	113	17.2	12.9	10.3	8.6
OC-12	30	1.04	102	20	15.1	12.1	10.1	113	18.2	13.7	10.9	9.1
	40	1.20	104	23	17.1	13.7	11.4	115	21	15.5	12.4	10.3
	60	1.47	105	28	21	16.6	13.9	116	25	18.8	15.1	12.5
OC-16	30	1.39	132	21	15.6	12.5	10.4	142	19.4	14.5	11.6	9.7
	40	1.60	138	23	17.2	13.8	11.5	146	22	16.3	13.0	10.8
	60	1.96	143	27	20	16.3	13.6	148	26	19.7	15.7	13.1

Note: Always double check your application rates. See pages 149-163 for useful formulas and information.



Features:

- Tapered edge flat spray pattern for uniform coverage in broadcast spraying.
- VisiFlo color-coded version available in stainless steel, ceramic and polymer in 80° or 110° spray angles in selected sizes.
- Available in ceramic 80° capacities 01–03 and 110° capacities 01–02. See XR and XRC TeeJet® tips on pages 10 and 11 for larger capacities.
- Available in brass in 110° spray angle only with VisiFlo color-coding.

- Standard version (not color-coded) available in 15°, 25°, 40°, 50° and 65° spray angles in brass, stainless steel or hardened stainless steel.
- See page 33 for TeeJet even flat spray tips.
- Automatic spray alignment with 25612-*NYR Quick TeeJet® cap and gasket. Reference page 55 for more information.
- Automatic spray alignment for sizes 10 thru 20 with 25610-*NYR Quick TeeJet cap and gasket. Reference page 55 for more information.

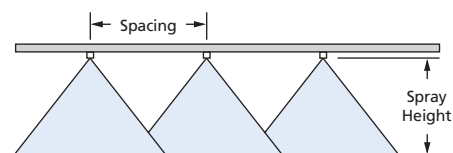

Optimum Spray Height

Tip Spray Angle	Optimum Spray Height
65°	90 cm
80°	75 cm
110°	50 cm

Reference technical section page 149 for more information.

How to order:

Specify tip number.

Examples:

- TP8002-VS – Stainless Steel with VisiFlo color-coding
- TP11002-VP – Polymer with VisiFlo color-coding
- TP11001-VK – Ceramic with VisiFlo polymer color-coding
- TP11002-HSS – Hardened Stainless Steel
- TP8002-SS – Stainless Steel
- TP8002 – Brass
- TP11004-VB – Brass with VisiFlo color-coding

Tip	Nozzle Size	Capacity One Nozzle	l/ha @ 50 cm												
			4 km/h	5 km/h	6 km/h	7 km/h	8 km/h	10 km/h	12 km/h	16 km/h	18 km/h	20 km/h	25 km/h	30 km/h	35 km/h
TP650050† TP800050† TP1100050† (100)	2.0	0.16	48.0	38.4	32.0	27.4	24.0	19.2	16.0	12.0	10.7	9.6	7.7	6.4	5.5
	2.5	0.18	54.0	43.2	36.0	30.9	27.0	21.6	18.0	13.5	12.0	10.8	8.6	7.2	6.2
	3.0	0.20	60.0	48.0	40.0	34.3	30.0	24.0	20.0	15.0	13.3	12.0	9.6	8.0	6.9
	3.5	0.22	66.0	52.8	44.0	37.7	33.0	26.4	22.0	16.5	14.7	13.2	10.6	8.8	7.5
TP650067† TP800067† TP1100067† (100)	2.0	0.21	63.0	50.4	42.0	36.0	31.5	25.2	21.0	15.8	14.0	12.6	10.1	8.4	7.2
	2.5	0.24	72.0	57.6	48.0	41.1	36.0	28.8	24.0	18.0	16.0	14.4	11.5	9.6	8.2
	3.0	0.26	78.0	62.4	52.0	44.6	39.0	31.2	26.0	19.5	17.3	15.6	12.5	10.4	8.9
	3.5	0.28	84.0	67.2	56.0	48.0	42.0	33.6	28.0	21.0	18.7	16.8	13.4	11.2	9.6
TP6501† TP8001 TP11001 (100)	2.0	0.32	96.0	76.8	64.0	54.9	48.0	38.4	32.0	24.0	21.3	19.2	15.4	12.8	11.0
	2.5	0.36	108	86.4	72.0	61.7	54.0	43.2	36.0	27.0	24.0	21.6	17.3	14.4	12.3
	3.0	0.39	117	93.6	78.0	66.9	58.5	46.8	39.0	29.3	26.0	23.4	18.7	15.6	13.4
	3.5	0.42	126	101	84.0	72.0	63.0	50.4	42.0	31.5	28.0	25.2	20.2	16.8	14.4
TP65015† TP80015 TP110015 (100)	2.0	0.48	144	115	96.0	82.3	72.0	57.6	48.0	36.0	32.0	28.8	23.0	19.2	16.5
	2.5	0.54	162	130	108	92.6	81.0	64.8	54.0	40.5	36.0	32.4	25.9	21.6	18.5
	3.0	0.59	177	142	118	101	88.5	70.8	59.0	44.3	39.3	35.4	28.3	23.6	20.2
	3.5	0.64	192	154	128	110	96.0	76.8	64.0	48.0	42.7	38.4	30.7	25.6	21.9
TP6502† TP8002 TP11002 (50)	2.0	0.65	195	156	130	111	97.5	81.6	65.0	48.8	43.3	39.0	31.2	26.0	22.3
	2.5	0.72	216	173	144	123	108	86.4	72.0	54.0	48.0	43.2	34.6	28.8	24.7
	3.0	0.79	237	190	158	135	119	94.8	79.0	59.3	52.7	47.4	37.9	31.6	27.1
	3.5	0.85	255	204	170	146	128	102	85.0	63.8	56.7	51.0	40.8	34.0	29.1
TP6503† TP8003 TP11003 (50)	2.0	0.96	288	230	192	165	144	115	96.0	72.0	64.0	57.6	46.1	38.4	32.9
	2.5	1.08	324	259	216	185	162	130	108	81.0	72.0	64.8	51.8	43.2	37.0
	3.0	1.18	354	283	236	202	177	142	118	88.5	78.7	70.8	56.6	47.2	40.5
	3.5	1.27	381	305	254	218	191	152	127	95.3	84.7	76.2	61.0	50.8	43.5
TP6504† TP8004 TP11004 (50)	2.0	1.29	387	310	258	221	194	155	129	96.8	86.0	77.4	61.9	51.6	44.2
	2.5	1.44	432	346	288	247	216	173	144	108	96.0	86.4	69.1	57.6	49.4
	3.0	1.58	474	379	316	271	237	190	158	119	105	94.8	75.8	63.2	54.2
	3.5	1.71	513	410	342	293	257	205	171	128	114	103	82.1	68.4	58.6
TP6505† TP8005 TP11005 (50)	2.0	1.82	546	437	364	312	273	218	182	137	121	109	87.4	72.8	62.4
	2.5	1.61	483	386	322	276	242	193	161	121	107	96.6	77.3	64.4	55.2
	2.5	1.80	540	432	360	309	270	216	180	135	120	108	86.4	72.0	61.7
	3.0	1.97	591	473	394	338	296	236	197	148	131	118	94.6	78.8	67.5
TP6506† TP8006 TP11006 (50)	2.5	2.13	639	511	426	365	320	256	213	160	142	128	102	85.2	73.0
	3.0	2.27	681	545	454	389	341	272	227	170	151	136	109	90.8	77.8
	2.0	1.94	582	466	388	333	291	233	194	146	129	116	93.1	77.6	66.5
	2.5	2.16	648	518	432	370	324	259	216	162	144	130	104	86.4	74.1
TP6508† TP8008 TP11008 (50)	3.0	2.37	711	569	474	406	356	284	237	178	158	142	114	94.8	81.3
	3.5	2.56	768	614	512	439	384	307	256	192	171	154	123	102	87.8
	4.0	2.74	822	658	548	470	411	329	274	206	183	164	132	110	93.9
	2.0	2.58	774	619	516	442	387	310	258	194	172	155	124	103	88.5
TP6510† TP8010† TP11010†	2.5	2.88	864	691	576	494	432	346	288	216	192	173	138	115	98.7
	3.0	3.16	948	758	632	542	474	379	316	237	211	190	152	126	108
	3.5	3.41	1023	818	682	585	512	409	341	256	227	205	164	136	117
	4.0	3.65	1095	876	730	626	548	438	365	274	243	219	175	146	125
TP6515† TP8015† TP11015†	2.0	3.23	969	775	646	554	485	388	323	242	215	194	155	129	111
	2.5	3.61	1083	866	722	619	542	433	361	271	241	217	173	144	124
	3.0	3.95	1185	948	790	677	593	474	395	296	263	237	190	158	135
	3.5	4.27	1281	1025	854	732	641	512	427	320	285	256	205	171	146
TP6520† TP8020† TP11020†	4.0	4.56	1368	1094	912	782	684	547	456	342	304	274	219	182	156
	2.0	4.83	1449	1159	966	828	725	580	483	362	322	290	232	193	166
	2.5	5.40	1620	1296	1080	926	810	648	540	405	360	324	259	216	185
	3.0	5.92	1776	1421	1184	1015	888	710	592	444	395	355	284	237	203
TP6520† TP8020† TP11020†	3.5	6.39	1917	1534	1278	1095	959	767	639	479	426	383	307	256	219
	4.0	6.84	2052	1642	1368	1173	1026	821	684	513	456	410	328	274	235
	2.0	6.44	1932	1546	1288	1104	966	773	644	483	429	386	309	258	221
	2.5	7.20	2160	1728	1440	1234	1080	864	720	540	480	432	346	288	247
TP6520† TP8020† TP11020†	3.0	7.89	2367	1894	1578	1353	1184	947	789	592	526	473	379	316	271
	3.5	8.52	2556	2045	1704	1461	1278	1022	852	639	568	511	409	341	292
	4.0	9.11	2733	2186	1822	1562	1367	1093	911	683	607	547	437	364	312

Note: Always double check your application rates. See pages 149-163 for useful formulas and information.
†Available in all brass, stainless steel, and hardened stainless steel only.



Features:

- Tapered edge flat spray pattern for uniform coverage in broadcast spraying.
- VisiFlo color-coded version available in stainless steel, ceramic and polymer in 80° or 110° spray angles in selected sizes.
- Available in ceramic 80° capacities 01–03 and 110° capacities 01–02. See XR and XRC TeeJet[®] tips on pages 10 and 11 for larger capacities.
- Available in brass in 110° spray angle only with VisiFlo color-coding.
- Standard version (not color-coded) available in 15°, 25°, 40°, 50° and 65° spray angles in brass, stainless steel or hardened stainless steel.
- See page 33 for TeeJet even flat spray tips.
- Automatic spray alignment with 25612-*-NYR Quick TeeJet[®] cap and gasket. Reference page 55 for more information.
- Automatic spray alignment for sizes 10 thru 20 with 25610-*-NYR Quick TeeJet cap and gasket. Reference page 55 for more information.



	PSI	CAPACITY ONE NOZZLE IN GPM	CAPACITY ONE NOZZLE IN OZ./MIN.	20°												GALLONS PER 1000 SQ. FT.				
				GPA																
				4 MPH	5 MPH	6 MPH	8 MPH	10 MPH	12 MPH	15 MPH	20 MPH	2 MPH	3 MPH	4 MPH	5 MPH					
TP650050 [†]	30	0.043	5.5	3.2	2.6	2.1	1.6	1.3	1.1	0.85	0.64	0.15	0.10	0.07	0.06					
TP800050 [†]	35	0.047	6.0	3.5	2.8	2.3	1.7	1.4	1.2	0.93	0.70	0.16	0.11	0.08	0.06					
TP1100050 [†] (100)	40	0.050	6.4	3.7	3.0	2.5	1.9	1.5	1.2	0.99	0.74	0.17	0.11	0.09	0.07					
	50	0.056	7.2	4.2	3.3	2.8	2.1	1.7	1.4	1.1	0.83	0.19	0.13	0.10	0.08					
	60	0.061	7.8	4.5	3.6	3.0	2.3	1.8	1.5	1.2	0.91	0.21	0.14	0.10	0.08					
TP650067 [†]	30	0.058	7.4	4.3	3.4	2.9	2.2	1.7	1.4	1.1	0.86	0.20	0.13	0.10	0.08					
TP800067 [†]	35	0.063	8.1	4.7	3.7	3.1	2.3	1.9	1.6	1.2	0.94	0.21	0.14	0.11	0.09					
TP1100067 [†] (100)	40	0.067	8.6	5.0	4.0	3.3	2.5	2.0	1.7	1.3	0.99	0.23	0.15	0.11	0.09					
	50	0.075	9.6	5.6	4.5	3.7	2.8	2.2	1.9	1.5	1.1	0.26	0.17	0.13	0.10					
	60	0.082	10	6.1	4.9	4.1	3.0	2.4	2.0	1.6	1.2	0.28	0.19	0.14	0.11					
TP6501 [†]	30	0.087	11	6.5	5.2	4.3	3.2	2.6	2.2	1.7	1.3	0.30	0.20	0.15	0.12					
TP8001	35	0.094	12	7.0	5.6	4.7	3.5	2.8	2.3	1.9	1.4	0.32	0.21	0.16	0.13					
TP11001 (100)	40	0.10	13	7.4	5.9	5.0	3.7	3.0	2.5	2.0	1.5	0.34	0.23	0.17	0.14					
	50	0.11	14	8.2	6.5	5.4	4.1	3.3	2.7	2.2	1.6	0.37	0.25	0.19	0.15					
	60	0.12	15	8.9	7.1	5.9	4.5	3.6	3.0	2.4	1.8	0.41	0.27	0.20	0.16					
TP65015 [†]	30	0.13	17	9.7	7.7	6.4	4.8	3.9	3.2	2.6	1.9	0.44	0.29	0.22	0.18					
TP80015	35	0.14	18	10.4	8.3	6.9	5.2	4.2	3.5	2.8	2.1	0.48	0.32	0.24	0.19					
TP110015 (100)	40	0.15	19	11.1	8.9	7.4	5.6	4.5	3.7	3.0	2.2	0.51	0.34	0.26	0.20					
	50	0.17	22	12.6	10.1	8.4	6.3	5.0	4.2	3.4	2.5	0.58	0.39	0.29	0.23					
	60	0.18	23	13.4	10.7	8.9	6.7	5.3	4.5	3.6	2.7	0.61	0.41	0.31	0.24					
TP6502 [†]	30	0.17	22	12.6	10.1	8.4	6.3	5.0	4.2	3.4	2.5	0.58	0.39	0.29	0.23					
TP8002	35	0.19	24	14.1	11.3	9.4	7.1	5.6	4.7	3.8	2.8	0.65	0.43	0.32	0.26					
TP11002 (50)	40	0.20	26	14.9	11.9	9.9	7.4	5.9	5.0	4.0	3.0	0.68	0.45	0.34	0.27					
	50	0.22	28	16.3	13.1	10.9	8.2	6.5	5.4	4.4	3.3	0.75	0.50	0.37	0.30					
	60	0.24	31	17.8	14.3	11.9	8.9	7.1	5.9	4.8	3.6	0.82	0.54	0.41	0.33					
TP6503 [†]	30	0.26	33	19.3	15.4	12.9	9.7	7.7	6.4	5.1	3.9	0.88	0.59	0.44	0.35					
TP8003	35	0.28	36	21	16.6	13.9	10.4	8.3	6.9	5.5	4.2	0.95	0.63	0.48	0.38					
TP11003 (50)	40	0.30	38	22	17.8	14.9	11.1	8.9	7.4	5.9	4.5	1.0	0.68	0.51	0.41					
	50	0.34	44	25	20	16.8	12.6	10.1	8.4	6.7	5.0	1.2	0.77	0.58	0.46					
	60	0.37	47	27	22	18.3	13.7	11.0	9.2	7.3	5.5	1.3	0.84	0.63	0.50					
TP6504 [†]	30	0.35	45	26	21	17.3	13.0	10.4	8.7	6.9	5.2	1.2	0.79	0.60	0.48					
TP8004	35	0.37	47	27	22	18.3	13.7	11.0	9.2	7.3	5.5	1.3	0.84	0.63	0.50					
TP11004 (50)	40	0.40	51	30	24	19.8	14.9	11.9	9.9	7.9	5.9	1.4	0.91	0.68	0.54					
	50	0.45	58	33	27	22	16.7	13.4	11.1	8.9	6.7	1.5	1.0	0.77	0.61					
	60	0.49	63	36	29	24	18.2	14.6	12.1	9.7	7.3	1.7	1.1	0.83	0.67					
TP6505 [†]	30	0.43	55	32	26	21	16.0	12.8	10.6	8.5	6.4	1.5	0.97	0.73	0.58					
TP8005	35	0.47	60	35	28	23	17.4	14.0	11.6	9.3	7.0	1.6	1.1	0.80	0.64					
TP11005 (50)	40	0.50	64	37	30	25	18.6	14.9	12.4	9.9	7.4	1.7	1.1	0.85	0.68					
	50	0.56	72	42	33	28	21	16.6	13.9	11.1	8.3	1.9	1.3	0.95	0.76					
	60	0.61	78	45	36	30	23	18.1	15.1	12.1	9.1	2.1	1.4	1.0	0.83					
TP6506 [†]	30	0.52	67	39	31	26	19.3	15.4	12.9	10.3	7.7	1.8	1.2	0.88	0.71					
TP8006	35	0.56	72	42	33	28	21	16.6	13.9	11.1	8.3	1.9	1.3	0.95	0.76					
TP11006 (50)	40	0.60	77	45	36	30	22	17.8	14.9	11.9	8.9	2.0	1.4	1.0	0.82					
	50	0.67	86	50	40	33	25	19.9	16.6	13.3	9.9	2.3	1.5	1.1	0.91					
	60	0.73	93	54	43	36	27	22	18.1	14.5	10.8	2.5	1.7	1.2	0.99					
TP6508 [†]	30	0.69	88	51	41	34	26	20	17.1	13.7	10.2	2.3	1.6	1.2	0.94					
TP8008	35	0.75	96	56	45	37	28	22	18.6	14.9	11.1	2.6	1.7	1.3	1.0					
TP11008 (50)	40	0.80	102	59	48	40	30	24	19.8	15.8	11.9	2.7	1.8	1.4	1.1					
	50	0.89	114	66	53	44	33	26	22	17.6	13.2	3.0	2.0	1.5	1.2					
	60	0.98	125	73	58	49	36	29	24	19.4	14.6	3.3	2.2	1.7	1.3					
TP6510 [†]	30	0.87	111	65	52	43	32	26	22	17.2	12.9	3.0	2.0	1.5	1.2					
TP8010 [†]	35	0.94	120	70	56	47	35	28	23	18.6	14.0	3.2	2.1	1.6	1.3					
TP11010 [†] (24)	40	1.00	128	74	59	50	37	30	25	19.8	14.9	3.4	2.3	1.7	1.4					
	50	1.12	143	83	67	55	42	33	28	22	16.6	3.8	2.5	1.9	1.5					
	60	1.22	156	91	72	60	45	36	30	24	18.1	4.1	2.8	2.1	1.7					
TP6515 [†]	30	1.30	166	97	77	64	48	39	32	26	19.3	4.4	2.9	2.2	1.8					
TP8015 [†]	35	1.40	179	104	83	69	52	42	35	28	21	4.8	3.2	2.4	1.9					
TP11015 [†]	40	1.50	192	111	89	74	56	45	37	30	22	5.1	3.4	2.6	2.0					
	50	1.68	215	125	100	83	62	50	42	33	25	5.7	3.8	2.9	2.3					
	60	1.84	236	137	109	91	68	55	46	36	27	6.3	4.2	3.1	2.5					
TP6520 [†]	30	1.73	221	128	103	86	64	51	43	34	26	5.9	3.9	2.9	2.4					
TP8020 [†]	35	1.87	239	139	111	93	69	56	46	37	28	6.4	4.2	3.2	2.5					
TP11020 [†]	40	2.00	256	149	119	99	74	59	50	40	30	6.8	4.5	3.4	2.7					
	50	2.24	287	166	133	111	83	67	55	44	33	7.6	5.1	3.8	3.0					
	60	2.45	314	182	146	121	91	73	61	49	36	8.3	5.6	4.2	3.3					

Note: Always double check your application rates. See pages 149–163 for useful formulas and information.
[†]Available in all brass, stainless steel, and hardened stainless steel only.

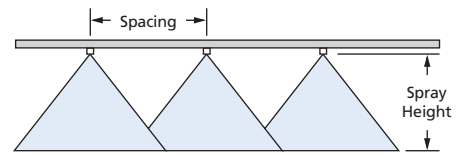

Optimum Spray Height

20°	20°
65°	35"
80°	30"
110°	20"

Reference technical section page 149 for more information.

How to order:

Specify tip number.

Examples:

- TP8002-VS – Stainless Steel with VisiFlo color-coding
- TP11002-VP – Polymer with VisiFlo color-coding
- TP11001-VK – Ceramic with VisiFlo polymer color-coding
- TP11002-HSS – Hardened Stainless Steel
- TP8002-SS – Stainless Steel
- TP8002 – Brass
- TP11004-VB – Brass with VisiFlo color-coding



XP BoomJet® Boomless Flat Spray Nozzles

Typical Applications:

- Boomless field spray applications.
- Roadside and right-of-way applications.
- End row spraying.
- Orchard spraying.
- De-icing applications.
- Forestry.

Features:

- Unique orifice geometry produces a wide spray pattern while maintaining superior distribution across entire width.
- Pre-orifice design minimizes drift.
- Extra wide spray pattern — up to 18.5 feet (5.5 meters) — using a single nozzle.
- Removable polymer pre-orifice.
- Acetal or stainless steel construction for excellent chemical resistance.
- Recommended spray pressure range: 20–60 PSI (1.5–4 bar).

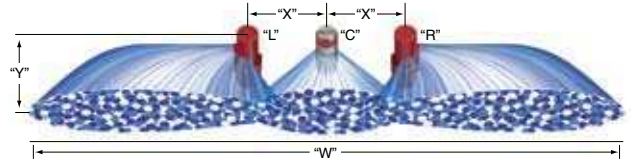

"R", "L"	CENTER NOZZLE "C"	bar	DROP SIZE	CAPACITY THREE NOZZLES IN l/min	SPRAY WIDTH "W" (meters)		I/ha FOR THREE NOZZLES															
					60 cm HEIGHT	90 cm HEIGHT	NOZZLE SPACING "X" = 50 cm															
							HEIGHT "Y" = 60 cm				HEIGHT "Y" = 90 cm				HEIGHT "Y" = 60 cm				HEIGHT "Y" = 90 cm			
						4 km/h	8 km/h	12 km/h	16 km/h	24 km/h	32 km/h	4 km/h	8 km/h	12 km/h	16 km/h	24 km/h	32 km/h					
(B)1/4XP10R (B)1/4XP10L	1/4TTJ08	1.5	XC	7.85	6.2	7.0	190	95.0	63.3	47.5	31.7	23.7	168	84.1	56.1	42.1	28.0	21.0				
		2.0	XC	9.04	7.0	7.8	194	96.9	64.6	48.4	32.3	24.2	174	86.9	57.9	43.5	29.0	21.7				
		3.0	XC	11.1	7.8	8.6	213	107	71.2	53.4	35.6	26.7	194	96.8	64.5	48.4	32.3	24.2				
		4.0	XC	13.2	8.6	9.2	213	106	70.9	53.2	35.5	26.6	199	99.5	66.3	49.7	33.2	24.9				
(B)1/4XP20R (B)1/4XP20L	1/4TTJ08	1.5	XC	13.4	6.4	7.8	314	157	105	78.5	52.3	39.3	258	129	85.9	64.4	42.9	32.2				
		2.0	XC	15.4	8.0	8.4	289	144	96.3	72.2	48.1	36.1	275	138	91.7	68.8	45.8	34.4				
		3.0	XC	18.9	9.2	9.6	308	154	103	77.0	51.4	38.5	295	148	98.4	73.8	49.2	36.9				
		4.0	XC	20.7	9.8	10.2	317	158	106	79.2	52.8	39.6	304	152	101	76.1	50.7	38.1				
(B)1/4XP25R (B)1/4XP25L	1/4TTJ10	1.5	XC	16.5	7.4	7.8	334	167	111	83.6	55.7	41.8	317	159	106	79.3	52.9	39.7				
		2.0	XC	19.1	8.4	9.2	341	171	114	85.3	56.8	42.6	311	156	104	77.9	51.9	38.9				
		3.0	XC	23.5	9.2	9.8	383	192	128	95.8	63.9	47.9	360	180	120	89.9	59.9	45.0				
		4.0	XC	25.6	9.8	10.2	392	196	131	98.0	65.3	49.0	376	188	125	94.1	62.7	47.1				
(B)1/2XP40R (B)1/2XP40L	1/4TTJ15	1.5	XC	26.6	7.8	8.4	512	256	171	128	85.3	63.9	475	238	158	119	79.2	59.4				
		2.0	XC	31.0	9.0	9.8	517	258	172	129	86.1	64.6	474	237	158	119	79.1	59.3				
		3.0	XC	37.7	9.6	10.4	589	295	196	147	98.2	73.6	544	272	181	136	90.6	68.0				
		4.0	XC	40.8	10.2	10.8	600	300	200	150	100	75.0	567	283	189	142	94.4	70.8				

"R", "L"	CENTER NOZZLE "C"	bar	DROP SIZE	CAPACITY THREE NOZZLES IN l/min	SPRAY WIDTH "W" (meters)		I/ha FOR THREE NOZZLES															
					60 cm HEIGHT	90 cm HEIGHT	NOZZLE SPACING "X" = 75 cm															
							HEIGHT "Y" = 60 cm				HEIGHT "Y" = 90 cm				HEIGHT "Y" = 60 cm				HEIGHT "Y" = 90 cm			
						4 km/h	8 km/h	12 km/h	16 km/h	24 km/h	32 km/h	4 km/h	8 km/h	12 km/h	16 km/h	24 km/h	32 km/h					
(B)1/4XP10R (B)1/4XP10L	1/4TTJ06 (50)	1.5	XC	7.30	6.7	7.5	163	81.7	54.5	40.9	27.2	20.4	146	73.0	48.7	36.5	24.3	18.3				
		2.0	XC	8.40	7.5	8.3	168	84.0	56.0	42.0	28.0	21.0	152	75.9	50.6	38.0	25.3	19.0				
		3.0	XC	10.3	8.3	9.1	186	93.1	62.0	46.5	31.0	23.3	170	84.9	56.6	42.4	28.3	21.2				
		4.0	XC	11.3	9.1	9.7	186	93.1	62.1	46.6	31.0	23.3	175	87.4	58.2	43.7	29.1	21.8				
(B)1/4XP20R (B)1/4XP20L	1/4TTJ06 (50)	1.5	XC	12.8	6.9	8.3	278	139	92.8	69.6	46.4	34.8	231	116	77.1	57.8	38.6	28.9				
		2.0	XC	14.8	8.5	8.9	261	131	87.1	65.3	43.5	32.6	249	125	83.1	62.4	41.6	31.2				
		3.0	XC	18.1	9.7	10.1	280	140	93.3	70.0	46.6	35.0	269	134	89.6	67.2	44.8	33.6				
		4.0	XC	19.8	10.3	10.7	288	144	96.1	72.1	48.1	36.0	278	139	92.5	69.4	46.3	34.7				
(B)1/4XP25R (B)1/4XP25L	1/4TTJ08	1.5	XC	15.9	7.9	8.3	302	151	101	75.5	50.3	37.7	287	144	95.8	71.8	47.9	35.9				
		2.0	XC	18.5	8.9	9.7	312	156	104	77.9	52.0	39.0	286	143	95.4	71.5	47.7	35.8				
		3.0	XC	22.7	9.7	10.3	351	176	117	87.8	58.5	43.9	331	165	110	82.6	55.1	41.3				
		4.0	XC	24.7	10.3	10.7	360	180	120	89.9	60.0	45.0	346	173	115	86.6	57.7	43.3				
(B)1/2XP40R (B)1/2XP40L	1/4TTJ10	1.5	XC	25.2	8.3	8.9	455	228	152	114	75.9	56.9	425	212	142	106	70.8	53.1				
		2.0	XC	29.4	9.5	10.3	464	232	155	116	77.4	58.0	428	214	143	107	71.4	53.5				
		3.0	XC	35.8	10.1	10.9	532	266	177	133	88.6	66.5	493	246	164	123	82.1	61.6				
		4.0	XC	38.6	10.7	11.3	541	271	180	135	90.2	67.6	512	256	171	128	85.4	64.0				
(B)1/2XP80R (B)1/2XP80L	1/4TTJ15	1.5	XC	48.4	9.5	10.9	764	382	255	191	127	95.5	666	333	222	167	111	83.3				
		2.0	XC	55.8	10.7	11.5	782	391	261	196	130	97.8	728	364	243	182	121	91.0				
		3.0	XC	68.1	11.3	12.1	904	452	301	226	151	113	844	422	281	211	141	106				
		4.0	XC	73.2	11.5	12.5	955	477	318	239	159	119	878	439	293	220	146	110				

Note: Always double check your application rates.
 Tabulations are based on spraying water at 70°F (21°C).
 See pages 173–187 for drop size classification, useful formulas and information.

(B)=BSPT





- NPT or BSPT (male) threads for easy installation.
- Color-coding for easy capacity identification.

How to order:

Specify part number.

Example:

(B)1/2XP80L(R)-VS – VisiFlo® Stainless Steel left boom spray

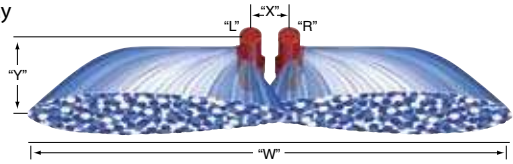

Nozzle "R", "L"	bar	DROP SIZE	CAPACITY TWO NOZZLE IN l/min	SPRAY WIDTH "W" (meters)		NOZZLE SPACING "X" = 0-7 cm														l/ha FOR TWO NOZZLES													
				60 cm HEIGHT	90 cm HEIGHT	HEIGHT "Y" = 60 cm														HEIGHT "Y" = 90 cm													
						4	6	8	10	12	16	20	25	30	35	4	6	8	10	12	16	20	25	30	35								
				km/h	km/h	km/h	km/h	km/h	km/h	km/h	km/h	km/h	km/h	km/h	km/h	km/h	km/h	km/h	km/h	km/h	km/h	km/h	km/h	km/h									
(B)1/4XP10R (B)1/4XP10L	1.5	XC	5.62	5.2	6.0	162	108	81.1	64.8	54.0	40.5	32.4	25.9	21.6	18.5	141	93.7	70.3	56.2	46.8	35.1	28.1	22.5	18.7	16.1								
	2.0	XC	6.46	6.0	6.8	162	108	80.8	64.6	53.8	40.4	32.3	25.8	21.5	18.5	143	95.0	71.3	57.0	47.5	35.6	28.5	22.8	19.0	16.3								
	3.0	XC	7.90	6.8	7.6	174	116	87.1	69.7	58.1	43.6	34.9	27.9	23.2	19.9	156	104	78.0	62.4	52.0	39.0	31.2	24.9	20.8	17.8								
	4.0	XC	9.10	8.0	8.8	171	114	85.3	68.3	56.9	42.7	34.1	27.3	22.8	19.5	155	103	77.6	62.0	51.7	38.8	31.0	24.8	20.7	17.7								
(B)1/4XP20R (B)1/4XP20L	1.5	XC	11.1	5.4	6.8	308	206	154	123	103	77.1	61.7	49.3	41.1	35.2	245	163	122	97.9	81.6	61.2	49.0	39.2	32.6	28.0								
	2.0	XC	12.9	7.0	7.4	276	184	138	111	92.1	69.1	55.3	44.2	36.9	31.6	261	174	131	105	87.2	65.4	52.3	41.8	34.9	29.9								
	3.0	XC	15.7	8.2	8.6	287	191	144	115	95.7	71.8	57.4	46.0	38.3	32.8	274	183	137	110	91.3	68.5	54.8	43.8	36.5	31.3								
	4.0	XC	18.2	9.2	9.8	297	198	148	119	98.9	74.2	59.3	47.5	39.6	33.9	279	186	139	111	92.9	69.6	55.7	44.6	37.1	31.8								
(B)1/4XP25R (B)1/4XP25L	1.5	XC	13.7	6.4	6.8	321	214	161	128	107	80.3	64.2	51.4	42.8	36.7	302	201	151	121	101	75.6	60.4	48.4	40.3	34.5								
	2.0	XC	15.9	7.4	8.2	322	215	161	129	107	80.6	64.5	51.6	43.0	36.8	291	194	145	116	97.0	72.7	58.2	46.5	38.8	33.2								
	3.0	XC	19.5	8.2	8.8	357	238	178	143	119	89.2	71.3	57.1	47.6	40.8	332	222	166	133	111	83.1	66.5	53.2	44.3	38.0								
	4.0	XC	21.0	8.8	9.2	358	239	179	143	119	89.5	71.6	57.3	47.7	40.9	342	228	171	137	114	85.6	68.5	54.8	45.7	39.1								
(B)1/2XP40R (B)1/2XP40L	1.5	XC	22.4	6.8	7.4	494	329	247	198	165	124	98.8	79.1	65.9	56.5	454	303	227	182	151	114	90.8	72.6	60.5	51.9								
	2.0	XC	26.2	8.0	8.8	491	328	246	197	164	123	98.3	78.6	65.5	56.1	447	298	223	179	149	112	89.3	71.5	59.5	51.0								
	3.0	XC	31.8	8.6	9.4	555	370	277	222	185	139	111	88.7	74.0	63.4	507	338	254	203	169	127	101	81.2	67.7	58.0								
	4.0	XC	36.8	9.8	10.6	563	376	282	225	188	141	113	90.1	75.1	64.4	521	347	260	208	174	130	104	83.3	69.4	59.5								
(B)1/2XP80R (B)1/2XP80L	1.5	XC	44.2	8.0	9.4	829	553	414	332	276	207	166	133	111	94.7	705	470	353	282	235	176	141	113	94.0	80.6								
	2.0	XC	51.0	9.2	10.0	832	554	416	333	277	208	166	133	111	95.0	765	510	383	306	255	191	153	122	102	87.4								
	3.0	XC	62.2	9.8	10.6	952	635	476	381	317	238	190	152	127	109	880	587	440	352	293	220	176	141	117	101								
	4.0	XC	66.4	10.0	11.0	996	664	498	398	332	249	199	159	133	114	905	604	453	362	302	226	181	145	121	103								

Note: Always double check your application rates.
 Tabulations are based on spraying water at 70°F (21°C).
 See pages 173-187 for drop size classification, useful formulas and information.

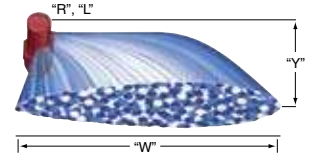

Nozzle "R", "L"	bar	DROP SIZE	CAPACITY ONE NOZZLE IN l/min	SPRAY WIDTH "W" (meters)		NOZZLE SPACING "X" = 0-7 cm														l/ha FOR SINGLE NOZZLE													
				60 cm HEIGHT	90 cm HEIGHT	HEIGHT "Y" = 60 cm														HEIGHT "Y" = 90 cm													
						4	6	8	10	12	16	20	25	30	35	4	6	8	10	12	16	20	25	30	35								
				km/h	km/h	km/h	km/h	km/h	km/h	km/h	km/h	km/h	km/h	km/h	km/h	km/h	km/h	km/h	km/h	km/h	km/h	km/h	km/h	km/h									
(B)1/4XP10R (B)1/4XP10L	1.5	XC	2.81	2.6	3.0	162	108	81.1	64.8	54.0	40.5	32.4	25.9	21.6	18.5	141	93.7	70.3	56.2	46.8	35.1	28.1	22.5	18.7	16.1								
	2.0	XC	3.23	3.0	3.4	162	108	80.8	64.6	53.8	40.4	32.3	25.8	21.5	18.5	143	95.0	71.3	57.0	47.5	35.6	28.5	22.8	19.0	16.3								
	3.0	XC	3.95	3.4	3.8	174	116	87.1	69.7	58.1	43.6	34.9	27.9	23.2	19.9	156	104	78.0	62.4	52.0	39.0	31.2	24.9	20.8	17.8								
	4.0	XC	4.26	3.8	4.1	168	112	84.1	67.3	56.1	42.0	33.6	26.9	22.4	19.2	156	104	77.9	62.3	52.0	39.0	31.2	24.9	20.8	17.8								
(B)1/4XP20R (B)1/4XP20L	1.5	XC	5.56	2.7	3.4	309	206	154	124	103	77.2	61.8	49.4	41.2	35.3	245	164	123	98.1	81.8	61.3	49.1	39.2	32.7	28.0								
	2.0	XC	6.43	3.5	3.7	276	184	138	110	91.9	68.9	55.1	44.1	36.7	31.5	261	174	130	104	86.9	65.2	52.1	41.7	34.8	29.8								
	3.0	XC	7.87	4.1	4.3	288	192	144	115	96.0	72.0	57.6	46.1	38.4	32.9	275	183	137	110	91.5	68.6	54.9	43.9	36.6	31.4								
	4.0	XC	8.52	4.4	4.6	290	194	145	116	96.8	72.6	58.1	46.5	38.7	33.2	278	185	139	111	92.6	69.5	55.6	44.5	37.0	31.8								
(B)1/4XP25R (B)1/4XP25L	1.5	XC	9.12	4.6	4.9	297	198	149	119	99.1	74.3	59.5	47.6	39.7	34.0	279	186	140	112	93.1	69.8	55.8	44.7	37.2	31.9								
	2.0	XC	6.85	3.2	3.4	321	214	161	128	107	80.3	64.2	51.4	42.8	36.7	302	201	151	121	101	75.6	60.4	48.4	40.3	34.5								
	3.0	XC	7.95	3.7	4.1	322	215	161	129	107	80.6	64.5	51.6	43.0	36.8	291	194	145	116	97.0	72.7	58.2	46.5	38.8	33.2								
	4.0	XC	9.77	4.1	4.4	357	238	179	143	119	89.4	71.5	57.2	47.7	40.9	333	222	167	133	111	83.3	66.6	53.3	44.4	38.1								
(B)1/2XP40R (B)1/2XP40L	1.5	XC	10.5	4.4	4.6	358	239	179	143	119	89.5	71.6	57.3	47.7	40.9	342	228	171	137	114	85.6	68.5	54.8	45.7	39.1								
	2.0	XC	11.2	4.6	4.9	365	243	183	146	122	91.3	73.0	58.4	48.7	41.7	343	229	171	137	114	85.7	68.6	54.9	45.7	39.2								
	3.0	XC	11.2	3.4	3.7	494	329	247	198	165	124	98.8	79.1	65.9	56.5	454	303	227	182	151	114	90.8	72.6	60.5	51.9								
	4.0	XC	13.1	4.0	4.4	491	328	246	197	164	123	98.3	78.6	65.5	56.1	447	298	223	179	149	112	89.3	71.5	59.5	51.0								
(B)1/2XP80R (B)1/2XP80L	1.5	XC	15.9	4.3	4.7	555	370	277	222	185	139	111	88.7	74.0	63.4	507	338	254	203	169	127	101	81.2	67.7	58.0								
	2.0	XC	17.0	4.6	4.9	554	370	277	222	185	139	111	88.7	73.9	63.4	520	347	260	208	173	130	104	83.3	69.4	59.5								
	3.0	XC	18.4	4.9	5.3	563	376	282	225	188	141	113	90.1	75.1	64.4	521	347	260	208	174	130	104	83.3	69.4	59.5								
	4.0	XC	22.1	4.0	4.7	829	553	414	332	276	207	166	133	111	94.7	705	470	353	282	235	176	141	113	94.0	80.6								

Note: Always double check your application rates.
 Tabulations are based on spraying water at 70°F (21°C).
 See pages 173-187 for drop size classification, useful formulas and information.

- (B)=BSPT
- Very Fine
 - Fine
 - Medium
 - Coarse
 - Very Coarse
 - Extremely Coarse



XP BoomJet® Boomless Flat Spray Nozzles

Typical Applications:

- Boomless field spray applications.
- Roadside and right-of-way applications.
- End row spraying.
- Orchard spraying.
- De-icing applications.
- Forestry.

Features:

- Unique orifice geometry produces a wide spray pattern while maintaining superior distribution across entire width.
- Pre-orifice design minimizes drift.
- Extra wide spray pattern — up to 18.5 feet (5.5 meters) — using a single nozzle.
- Removable polymer pre-orifice.
- Acetal or stainless steel construction for excellent chemical resistance.
- Recommended spray pressure range: 20–60 PSI (1.5–4 bar).

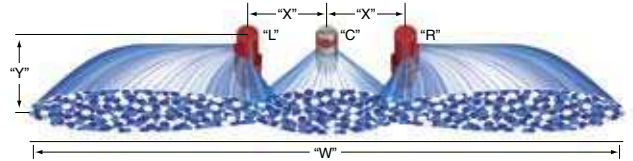

CENTER NOZZLE "C"	PSI	DROP SIZE	CAPACITY THREE NOZZLES IN GPM	SPRAY WIDTH "W" (FEET)		NOZZLE SPACING "X" = 20"																				
						HEIGHT = 24"										HEIGHT = 36"										
						GPA FOR THREE NOZZLES					GALLONS PER 1000 SQ. FT.					GPA FOR THREE NOZZLES					GALLONS PER 1000 SQ. FT.					
						24" HEIGHT	36" HEIGHT	4 MPH	6 MPH	8 MPH	10 MPH	15 MPH	20 MPH	2 MPH	3 MPH	4 MPH	5 MPH	4 MPH	6 MPH	8 MPH	10 MPH	15 MPH	20 MPH	2 MPH	3 MPH	4 MPH
(B)1/4XP10R (B)1/4XP10L	1/4TTJ08	30	XC	2.43	23.3	25.3	12.9	8.6	6.5	5.2	3.4	2.6	0.59	0.39	0.30	0.24	11.9	7.9	5.9	4.8	3.2	2.4	0.54	0.36	0.27	0.22
		40	XC	2.80	25.3	28.3	13.7	9.1	6.8	5.5	3.7	2.7	0.63	0.42	0.31	0.25	12.2	8.2	6.1	4.9	3.3	2.4	0.56	0.37	0.28	0.22
		50	XC	3.13	28.3	30.3	13.7	9.1	6.8	5.5	3.6	2.7	0.63	0.42	0.31	0.25	12.8	8.5	6.4	5.1	3.4	2.6	0.59	0.39	0.29	0.23
(B)1/4XP20R (B)1/4XP20L	1/4TTJ08	30	XC	4.19	26.3	27.3	19.7	13.1	9.9	7.9	5.3	3.9	0.90	0.60	0.45	0.36	19.0	12.7	9.5	7.6	5.1	3.8	0.87	0.58	0.43	0.35
		40	XC	4.80	30.3	31.3	19.6	13.1	9.8	7.8	5.2	3.9	0.90	0.60	0.45	0.36	19.0	12.7	9.5	7.6	5.1	3.8	0.87	0.58	0.43	0.35
		50	XC	5.39	32.3	33.3	21	13.8	10.3	8.3	5.5	4.1	0.95	0.63	0.47	0.38	20	13.4	10.0	8.0	5.3	4.0	0.92	0.61	0.46	0.37
(B)1/4XP25R (B)1/4XP25L	1/4TTJ10	30	XC	5.13	27.3	30.3	23	15.5	11.6	9.3	6.2	4.7	1.1	0.71	0.53	0.43	21	14.0	10.5	8.4	5.6	4.2	0.96	0.64	0.48	0.38
		40	XC	6.00	30.3	32.3	25	16.3	12.3	9.8	6.5	4.9	1.1	0.75	0.56	0.45	23	15.3	11.5	9.2	6.1	4.6	1.1	0.70	0.53	0.42
		50	XC	6.62	32.3	33.3	25	16.9	12.7	10.1	6.8	5.1	1.2	0.77	0.58	0.46	25	16.4	12.3	9.8	6.6	4.9	1.1	0.75	0.56	0.45
(B)1/2XP40R (B)1/2XP40L	1/4TTJ15	30	XC	8.36	29.3	32.3	35	24	17.7	14.1	9.4	7.1	1.6	1.1	0.81	0.65	32	21	16.0	12.8	8.5	6.4	1.5	0.98	0.73	0.59
		40	XC	9.50	31.3	34.3	38	25	18.8	15.0	10.0	7.5	1.7	1.1	0.86	0.69	34	23	17.1	13.7	9.1	6.9	1.6	1.0	0.78	0.63
		50	XC	10.8	33.3	35.3	40	27	20	16.1	10.7	8.0	1.8	1.2	0.92	0.74	38	25	18.9	15.1	10.1	7.6	1.7	1.2	0.87	0.69
60	XC	11.8	35.3	38.3	41	28	21	16.5	11.0	8.3	1.9	1.3	0.95	0.76	38	25	19.1	15.3	10.2	7.6	1.7	1.2	0.87	0.70		

CENTER NOZZLE "C"	PSI	DROP SIZE	CAPACITY THREE NOZZLES IN GPM	SPRAY WIDTH "W" (FEET)		NOZZLE SPACING "X" = 30"																				
						HEIGHT = 24"										HEIGHT = 36"										
						GPA FOR THREE NOZZLES					GALLONS PER 1000 SQ. FT.					GPA FOR THREE NOZZLES					GALLONS PER 1000 SQ. FT.					
						24" HEIGHT	36" HEIGHT	4 MPH	6 MPH	8 MPH	10 MPH	15 MPH	20 MPH	2 MPH	3 MPH	4 MPH	5 MPH	4 MPH	6 MPH	8 MPH	10 MPH	15 MPH	20 MPH	2 MPH	3 MPH	4 MPH
(B)1/4XP10R (B)1/4XP10L	1/4TTJ06 (50)	30	XC	2.26	25.0	27.0	11.2	7.5	5.6	4.5	3.0	2.2	0.51	0.34	0.26	0.20	10.4	6.9	5.2	4.1	2.8	2.1	0.47	0.32	0.24	0.19
		40	XC	2.60	27.0	30.0	11.9	7.9	6.0	4.8	3.2	2.4	0.55	0.36	0.27	0.22	10.7	7.2	5.4	4.3	2.9	2.1	0.49	0.33	0.25	0.20
		50	XC	2.91	30.0	32.0	12.0	8.0	6.0	4.8	3.2	2.4	0.55	0.37	0.27	0.22	11.3	7.5	5.6	4.5	3.0	2.3	0.52	0.34	0.26	0.21
(B)1/4XP20R (B)1/4XP20L	1/4TTJ06 (50)	30	XC	4.02	28.0	29.0	17.8	11.8	8.9	7.1	4.7	3.6	0.81	0.54	0.41	0.33	17.2	11.4	8.6	6.9	4.6	3.4	0.79	0.52	0.39	0.31
		40	XC	4.60	32.0	33.0	17.8	11.9	8.9	7.1	4.7	3.6	0.81	0.54	0.41	0.33	17.3	11.5	8.6	6.9	4.6	3.5	0.79	0.53	0.39	0.32
		50	XC	5.17	34.0	35.0	18.8	12.5	9.4	7.5	5.0	3.8	0.86	0.57	0.43	0.34	18.3	12.2	9.1	7.3	4.9	3.7	0.84	0.56	0.42	0.33
(B)1/4XP25R (B)1/4XP25L	1/4TTJ08	30	XC	4.95	29.0	32.0	21	14.1	10.6	8.4	5.6	4.2	0.97	0.64	0.48	0.39	19.1	12.8	9.6	7.7	5.1	3.8	0.88	0.58	0.44	0.35
		40	XC	5.80	32.0	34.0	22	15.0	11.2	9.0	6.0	4.5	1.0	0.68	0.51	0.41	21	14.1	10.6	8.4	5.6	4.2	0.97	0.64	0.48	0.39
		50	XC	6.39	34.0	35.0	23	15.5	11.6	9.3	6.2	4.7	1.1	0.71	0.53	0.43	23	15.1	11.3	9.0	6.0	4.5	1.0	0.69	0.52	0.41
(B)1/2XP40R (B)1/2XP40L	1/4TTJ10	30	XC	7.93	31.0	34.0	32	21	15.8	12.7	8.4	6.3	1.4	0.97	0.72	0.58	29	19.2	14.4	11.5	7.7	5.8	1.3	0.88	0.66	0.53
		40	XC	9.00	33.0	36.0	34	23	16.9	13.5	9.0	6.8	1.5	1.0	0.77	0.62	31	21	15.5	12.4	8.3	6.2	1.4	0.94	0.71	0.57
		50	XC	10.2	35.0	37.0	36	24	18.0	14.4	9.6	7.2	1.7	1.1	0.83	0.66	34	23	17.1	13.6	9.1	6.8	1.6	1.0	0.78	0.62
(B)1/2XP80R (B)1/2XP80L	1/4TTJ15	30	XC	15.0	35.0	38.0	53	35	27	21	14.1	10.6	2.4	1.6	1.2	0.97	49	33	24	19.5	13.0	9.8	2.2	1.5	1.1	0.89
		40	XC	17.5	37.0	40.0	59	39	29	23	15.6	11.7	2.7	1.8	1.3	1.1	54	36	27	22	14.4	10.8	2.5	1.7	1.2	0.99
		50	XC	19.1	38.0	41.0	62	41	31	25	16.6	12.4	2.8	1.9	1.4	1.1	58	38	29	23	15.4	11.5	2.6	1.8	1.3	1.1
60	XC	21.0	40.0	42.0	65	43	32	26	17.3	13.0	3.0	2.0	1.5	1.2	62	41	31	25	16.5	12.4	2.8	1.9	1.4	1.1		

Note: Always double check your application rates. Tabulations are based on spraying water at 70°F (21°C).

See pages 173–187 for drop size classification, useful formulas and information.

(B)=BSPT



XP BoomJet® Boomless Flat Spray Nozzles



- NPT or BSPT (male) threads for easy installation.
- Color-coding for easy capacity identification.

How to order:
Specify part number.
Example:

(B)1/2XP80L(R)-VS – VisiFlo® Stainless
Steel left boom spray

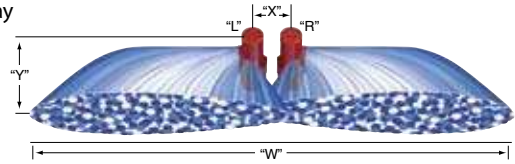

Nozzle "R", "L"	PSI	DROP SIZE	CAPACITY TWO NOZZLE IN GPM	SPRAY WIDTH "W" (FEET)		NOZZLE SPACING "X" = 0-3" 24"										NOZZLE SPACING "X" = 0-3" 36"									
				24" HEIGHT	36" HEIGHT	GPA FOR TWO NOZZLES					GALLONS PER 1000 SQ. FT.					GPA FOR TWO NOZZLES					GALLONS PER 1000 SQ. FT.				
						4 MPH	6 MPH	8 MPH	10 MPH	15 MPH	20 MPH	2 MPH	3 MPH	4 MPH	5 MPH	4 MPH	6 MPH	8 MPH	10 MPH	15 MPH	20 MPH	2 MPH	3 MPH	4 MPH	5 MPH
(B)1/4XP10R (B)1/4XP10L	20	XC	1.42	17.0	20.0	10.3	6.9	5.2	4.1	2.8	2.1	0.47	0.32	0.24	0.19	8.8	5.9	4.4	3.5	2.3	1.8	0.40	0.27	0.20	0.16
	30	XC	1.74	20.0	22.0	10.8	7.2	5.4	4.3	2.9	2.2	0.49	0.33	0.25	0.20	9.8	6.5	4.9	3.9	2.6	2.0	0.45	0.30	0.22	0.18
	40	XC	2.00	22.0	25.0	11.3	7.5	5.6	4.5	3.0	2.3	0.52	0.34	0.26	0.21	9.9	6.6	5.0	4.0	2.6	2.0	0.45	0.30	0.23	0.18
	50	XC	2.24	25.0	27.0	11.1	7.4	5.5	4.4	3.0	2.2	0.51	0.34	0.25	0.20	10.3	6.8	5.1	4.1	2.7	2.1	0.47	0.31	0.24	0.19
(B)1/4XP20R (B)1/4XP20L	20	XC	2.84	18.0	22.0	19.5	13.0	9.8	7.8	5.2	3.9	0.89	0.60	0.45	0.36	16.0	10.7	8.0	6.4	4.3	3.2	0.73	0.49	0.37	0.29
	30	XC	3.50	23.0	24.0	18.8	12.6	9.4	7.5	5.0	3.8	0.86	0.57	0.43	0.34	18.0	12.0	9.0	7.2	4.8	3.6	0.83	0.55	0.41	0.33
	40	XC	4.00	27.0	28.0	18.3	12.2	9.2	7.3	4.9	3.7	0.84	0.56	0.42	0.34	17.7	11.8	8.8	7.1	4.7	3.5	0.81	0.54	0.40	0.32
	50	XC	4.50	29.0	30.0	19.2	12.8	9.6	7.7	5.1	3.8	0.88	0.59	0.44	0.35	18.6	12.4	9.3	7.4	5.0	3.7	0.85	0.57	0.43	0.34
(B)1/4XP25R (B)1/4XP25L	20	XC	3.00	30.0	32.0	21	13.8	10.3	8.3	5.5	4.1	0.94	0.63	0.47	0.38	19.3	12.9	9.7	7.7	5.2	3.9	0.90	0.60	0.45	0.36
	30	XC	3.48	21.0	22.0	21	13.7	10.3	8.2	5.5	4.1	0.94	0.63	0.47	0.38	19.6	13.1	9.8	7.8	5.2	3.9	0.89	0.60	0.45	0.36
	40	XC	4.26	24.0	27.0	22	14.6	11.0	8.8	5.9	4.4	1.0	0.67	0.50	0.40	19.5	13.0	9.8	7.8	5.2	3.9	0.89	0.60	0.45	0.36
	50	XC	5.00	27.0	29.0	23	15.3	11.5	9.2	6.1	4.6	1.0	0.70	0.52	0.42	21	14.2	10.7	8.5	5.7	4.3	0.98	0.65	0.49	0.39
(B)1/2XP40R (B)1/2XP40L	20	XC	5.50	29.0	30.0	23	15.6	11.7	9.4	6.3	4.7	1.1	0.72	0.54	0.43	23	15.1	11.3	9.1	6.1	4.5	1.0	0.69	0.52	0.42
	30	XC	6.00	30.0	32.0	25	16.5	12.4	9.9	6.6	5.0	1.1	0.76	0.57	0.45	23	15.5	11.6	9.3	6.2	4.6	1.1	0.71	0.53	0.43
	40	XC	5.74	22.0	24.0	32	22	16.1	12.9	8.6	6.5	1.5	0.99	0.74	0.59	30	19.7	14.8	11.8	7.9	5.9	1.4	0.90	0.68	0.54
	50	XC	7.06	26.0	29.0	34	22	16.8	13.4	9.0	6.7	1.5	1.0	0.77	0.62	30	20	15.1	12.1	8.0	6.0	1.4	0.92	0.69	0.55
(B)1/2XP80R (B)1/2XP80L	20	XC	8.00	28.0	31.0	35	24	17.7	14.1	9.4	7.1	1.6	1.1	0.81	0.65	32	21	16.0	12.8	8.5	6.4	1.5	0.97	0.73	0.58
	30	XC	9.10	30.0	32.0	38	25	18.8	15.0	10.0	7.5	1.7	1.1	0.86	0.69	35	23	17.6	14.1	9.4	7.0	1.6	1.1	0.81	0.64
	40	XC	10.0	32.0	35.0	39	26	19.3	15.5	10.3	7.7	1.8	1.2	0.89	0.71	35	24	17.7	14.1	9.4	7.1	1.6	1.1	0.81	0.65
	60	XC	11.2	26.0	31.0	53	36	27	21	14.2	10.7	2.4	1.6	1.2	0.98	45	30	22	17.9	11.9	8.9	2.0	1.4	1.0	0.82
(B)1/2XP80R (B)1/2XP80L	30	XC	13.7	30.0	33.0	57	38	28	23	15.1	11.3	2.6	1.7	1.3	1.0	51	34	26	21	13.7	10.3	2.4	1.6	1.2	0.94
	40	XC	16.0	32.0	35.0	62	41	31	25	16.5	12.4	2.8	1.9	1.4	1.1	57	38	28	23	15.1	11.3	2.6	1.7	1.3	1.0
	50	XC	17.5	33.0	36.0	66	44	33	26	17.5	13.1	3.0	2.0	1.5	1.2	60	40	30	24	16.0	12.0	2.8	1.8	1.4	1.1
	60	XC	19.2	35.0	37.0	68	45	34	27	18.1	13.6	3.1	2.1	1.6	1.2	64	43	32	26	17.1	12.8	2.9	2.0	1.5	1.2

Note: Always double check your application rates.
Tabulations are based on spraying water at 70°F (21°C).
See pages 173-187 for drop size classification, useful formulas and information.

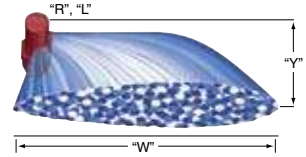

Nozzle "R", "L"	PSI	DROP SIZE	CAPACITY ONE NOZZLE IN GPM	SPRAY WIDTH "W" (FEET)		NOZZLE SPACING "X" = 0-3" 24"										NOZZLE SPACING "X" = 0-3" 36"									
				24" HEIGHT	36" HEIGHT	GPA FOR ONE NOZZLE					GALLONS PER 1000 SQ. FT.					GPA FOR ONE NOZZLE					GALLONS PER 1000 SQ. FT.				
						4 MPH	6 MPH	8 MPH	10 MPH	15 MPH	20 MPH	2 MPH	3 MPH	4 MPH	5 MPH	4 MPH	6 MPH	8 MPH	10 MPH	15 MPH	20 MPH	2 MPH	3 MPH	4 MPH	5 MPH
(B)1/4XP10R (B)1/4XP10L	20	XC	0.71	8.5	10.0	10.3	6.9	5.2	4.1	2.8	2.1	0.47	0.32	0.24	0.19	8.8	5.9	4.4	3.5	2.3	1.8	0.40	0.27	0.20	0.16
	30	XC	0.87	10.0	11.0	10.8	7.2	5.4	4.3	2.9	2.2	0.49	0.33	0.25	0.20	9.8	6.5	4.9	3.9	2.6	2.0	0.45	0.30	0.22	0.18
	40	XC	1.00	11.0	12.5	11.3	7.5	5.6	4.5	3.0	2.3	0.52	0.34	0.26	0.21	9.9	6.6	5.0	4.0	2.6	2.0	0.45	0.30	0.23	0.18
	50	XC	1.12	12.5	13.5	11.1	7.4	5.5	4.4	3.0	2.2	0.51	0.34	0.25	0.20	10.3	6.8	5.1	4.1	2.7	2.1	0.47	0.31	0.24	0.19
(B)1/4XP20R (B)1/4XP20L	20	XC	1.42	9.0	11.0	19.5	13.0	9.8	7.8	5.2	3.9	0.89	0.60	0.45	0.36	16.0	10.7	8.0	6.4	4.3	3.2	0.73	0.49	0.37	0.29
	30	XC	1.75	11.5	12.0	18.8	12.6	9.4	7.5	5.0	3.8	0.86	0.57	0.43	0.34	18.0	12.0	9.0	7.2	4.8	3.6	0.83	0.55	0.41	0.33
	40	XC	2.00	13.5	14.0	18.3	12.2	9.2	7.3	4.9	3.7	0.84	0.56	0.42	0.34	17.7	11.8	8.8	7.1	4.7	3.5	0.81	0.54	0.40	0.32
	50	XC	2.25	14.5	15.0	19.2	12.8	9.6	7.7	5.1	3.8	0.88	0.59	0.44	0.35	18.6	12.4	9.3	7.4	5.0	3.7	0.85	0.57	0.43	0.34
(B)1/4XP25R (B)1/4XP25L	20	XC	2.50	15.0	16.0	21	13.8	10.3	8.3	5.5	4.1	0.94	0.63	0.47	0.38	19.3	12.9	9.7	7.7	5.2	3.9	0.89	0.59	0.44	0.35
	30	XC	2.87	11.0	12.0	21	13.7	10.3	8.2	5.5	4.1	0.94	0.63	0.47	0.38	19.6	13.1	9.8	7.8	5.2	3.9	0.90	0.60	0.45	0.36
	40	XC	3.13	12.0	13.5	22	14.6	11.0	8.8	5.9	4.4	1.0	0.67	0.50	0.40	19.5	13.0	9.8	7.8	5.2	3.9	0.89	0.60	0.45	0.36
	50	XC	2.50	13.5	14.5	23	15.3	11.5	9.2	6.1	4.6	1.0	0.70	0.52	0.42	21	14.2	10.7	8.5	5.7	4.3	0.98	0.65	0.49	0.39
(B)1/2XP40R (B)1/2XP40L	20	XC	2.75	14.5	15.0	23	15.6	11.7	9.4	6.3	4.7	1.1	0.72	0.54	0.43	23	15.1	11.3	9.1	6.1	4.5	1.0	0.69	0.52	0.42
	30	XC	3.00	15.0	16.0	25	16.5	12.4	9.9	6.6	5.0	1.1	0.76	0.57	0.45	23	15.5	11.6	9.3	6.2	4.6	1.1	0.71	0.53	0.43
	40	XC	2.87	11.0	12.0	32	22	16.1	12.9	8.6	6.5	1.5	0.99	0.74	0.59	30	19.7	14.8	11.8	7.9	5.9	1.4	0.90	0.68	0.54
	50	XC	3.53	13.0	14.5	34	22	16.8	13.4	9.0	6.7	1.5	1.0	0.77	0.62	30	20	15.1	12.1	8.0	6.0	1.4	0.92	0.69	0.55
(B)1/2XP80R (B)1/2XP80L	20	XC	4.00	14.0	15.5	35	24	17.7	14.1	9.4	7.1	1.6	1.1	0.81	0.65	32	21	16.0	12.8	8.5	6.4	1.5	0.97	0.73	0.58
	30	XC	4.55	15.0	16.0	38	25	18.8	15.0	10.0	7.5	1.7	1.1	0.86	0.69	35	23	17.6	14.1	9.4	7.0	1.6	1.1	0.81	0.64
	40	XC	5.00	16.0	17.5	39	26	19.3	15.5	10.3	7.7	1.8	1.2	0.89	0.71	35	24	17.7	14.1	9.4	7.1	1.6	1.1	0.81	0.65
	60	XC	5.60	13.0	15.5	53	36	27	21	14.2	10.7	2.4	1.6	1.2	0.98	45	30	22	17.9	11.9	8.9	2.0	1.4	1.0	0.82
(B)1/2XP80R (B)1/2XP																									

