

horntools®

Name: Electric winch relay
SKU: H0050-24V_600

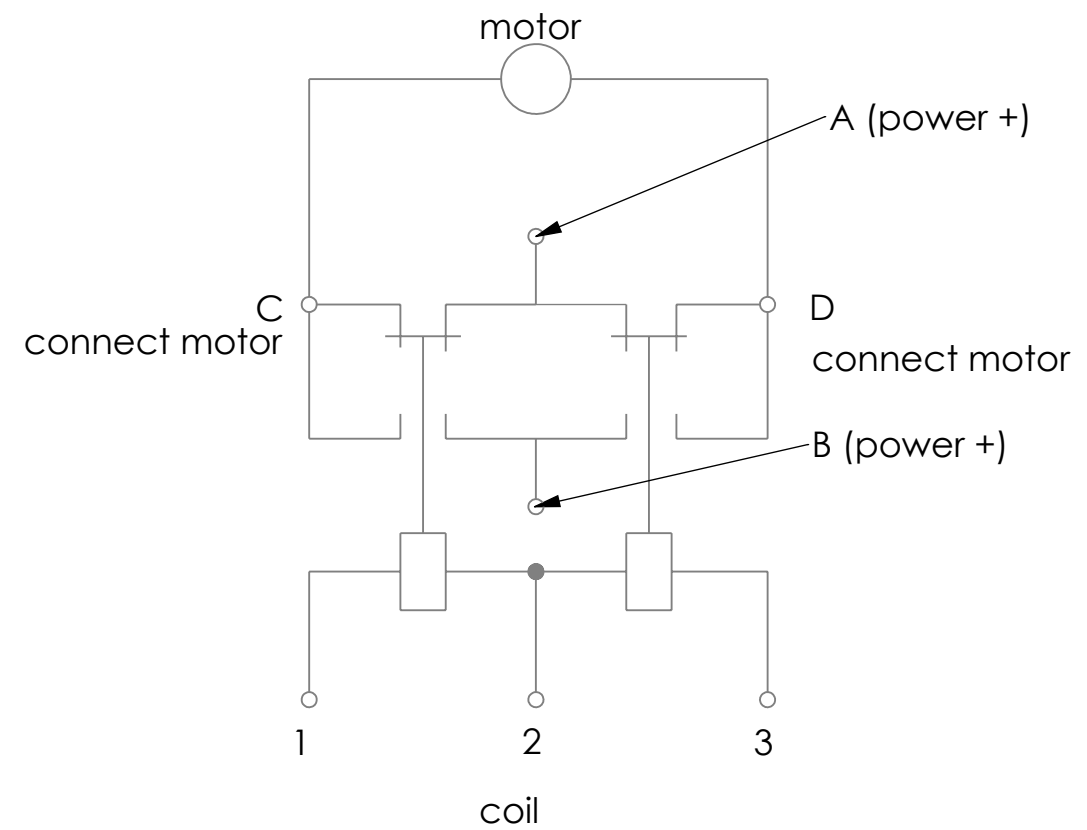
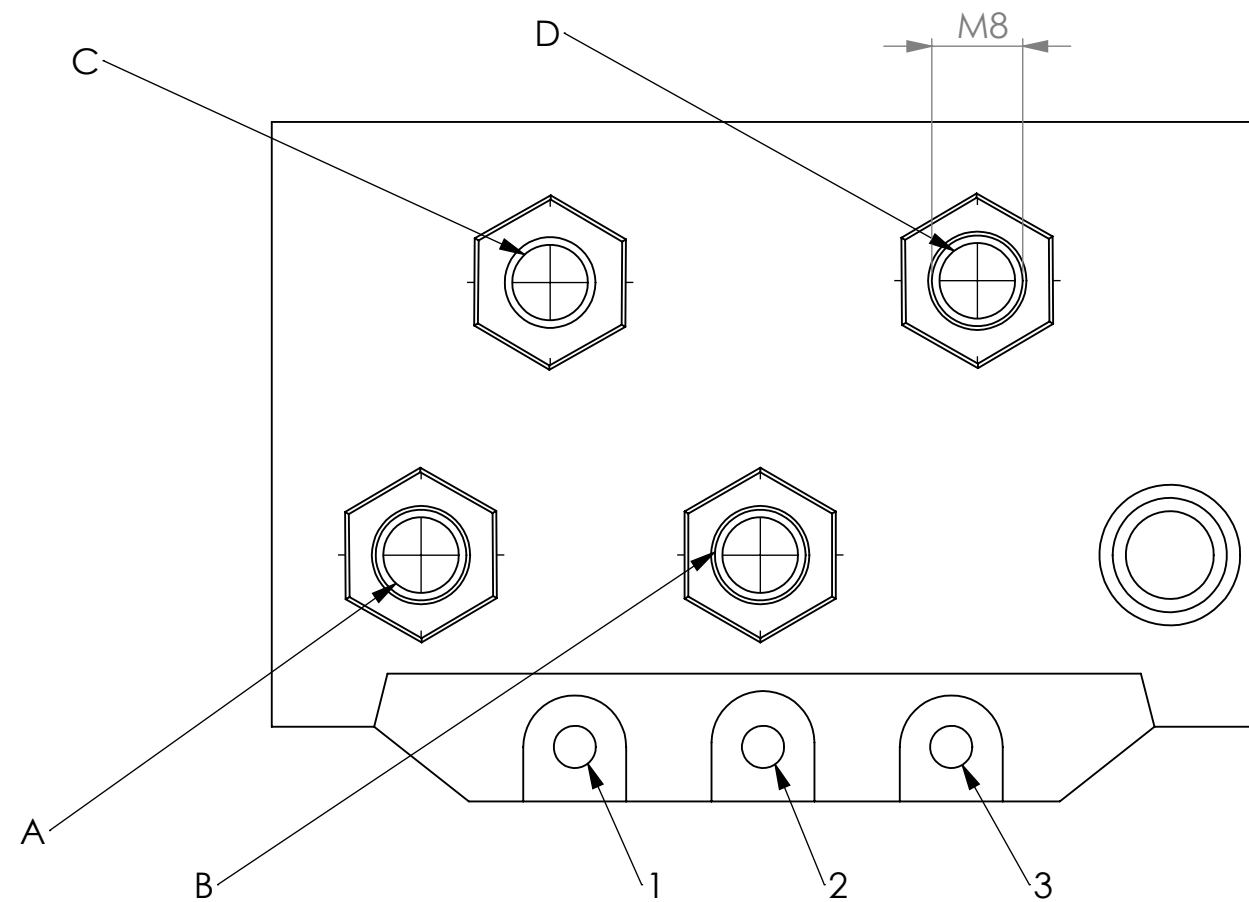

Technical Data

Model No.: H0050-24V_600
Power consumption: 16 W
Contact Arrangement: 2PDT
Contact Material: AgCdO
Contact Rating (at Resistive Load): 600A 24VDC
Contact circuit rated load current: continuous 50A, DE Short work interrupted 200A
Contact Resistance: Max. 50mΩ (initial)
Insulation Resistance: Min. 100mΩ at 500VDC
Puncture (volt) Strength: 1000 VAC 50Hz / 60 Hz (1 minute)
Operate Time: Max. 50mSec
Release Time: Max. 50mSec
Working Temperature: -25°C / +40°C