

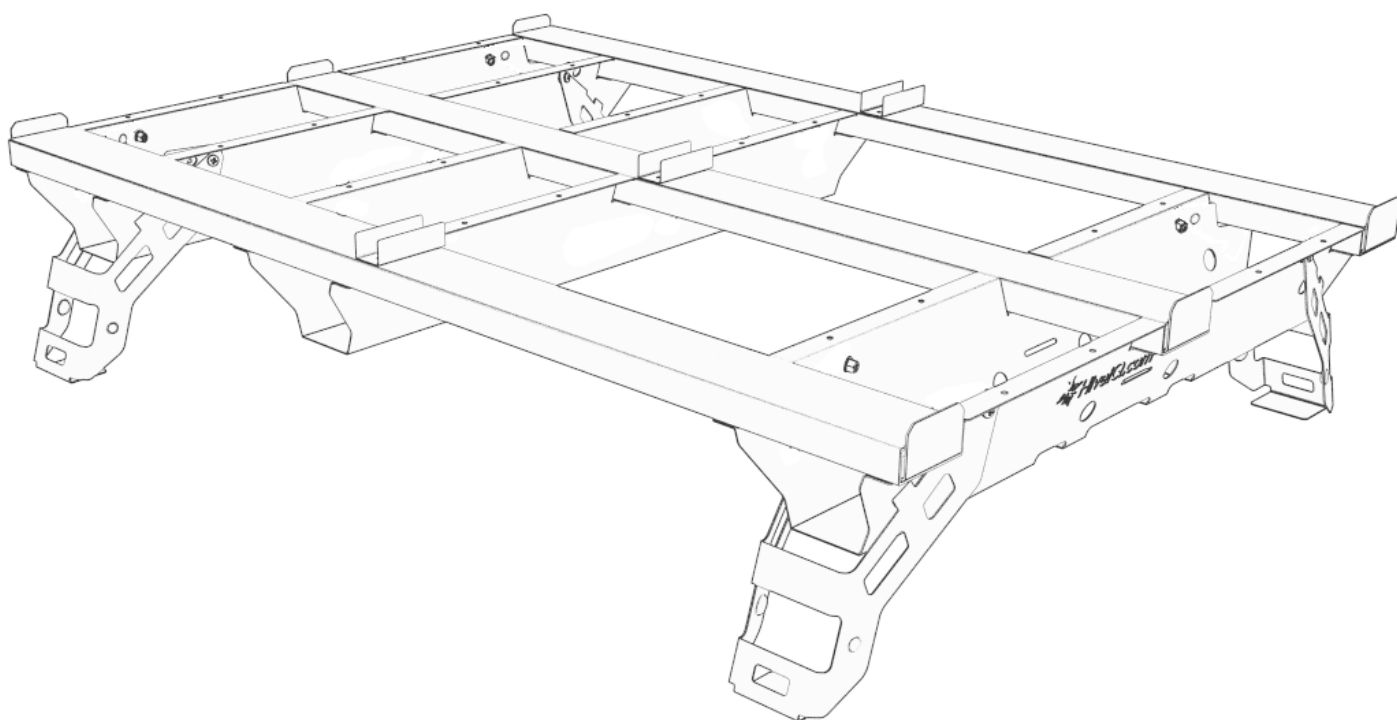

for healthy bees

4 Hive Stand Assembly Instructions



The HivelQ Beekeeping System

Better for the bees, better for the environment and better for the beekeeper

Designed for professional beekeepers: our stands (pallets) support an end to end, high performance, ruggedized beekeeping platform. The HivelQ stands create a palletised system is purpose designed for migratory beekeeping and pollination activity, for healthier bees during transport and to get your bees on ground faster all the while taking better care of beekeepers.

Our steel stands have a Trivalent Zinc coating which is high quality and highly resistant to corrosion. The stainless steel rivets provided are also highly corrosion resistant. The use of folding legs on the HivelQ hive stands raise hive height to a comfortable working height, minimising repetitive bending, reducing fatigue and injury to the beekeeper.



**If you get stuck or have a problem
with HivelQ products**

Scan here to submit a
ticket to the **HivelQ Help Desk**



Scan here to submit a ticket
to the HivelQ Help Desk



Content © HivelQ Pty Ltd
HivelQ Products are protected
by patents, design registrations
and trademarks.



Tools you need

You will need to supply the following tools and supplies (not included in the kit) to complete the assembly:

 **4mm (5/32) allan key or battery screw gun / drill and an allan key bit**

 **A rivet gun, standard size**

 **A 10mm (3/8) spanner**

 **A Hive tool**



We're making a better hive tool too...

Visit our website
to learn about the HIVEiQ
hive tool development



**4 Hive Stand
Assembly
Instructions**
Version 1.0



HiveIQ 4 Hive Stand

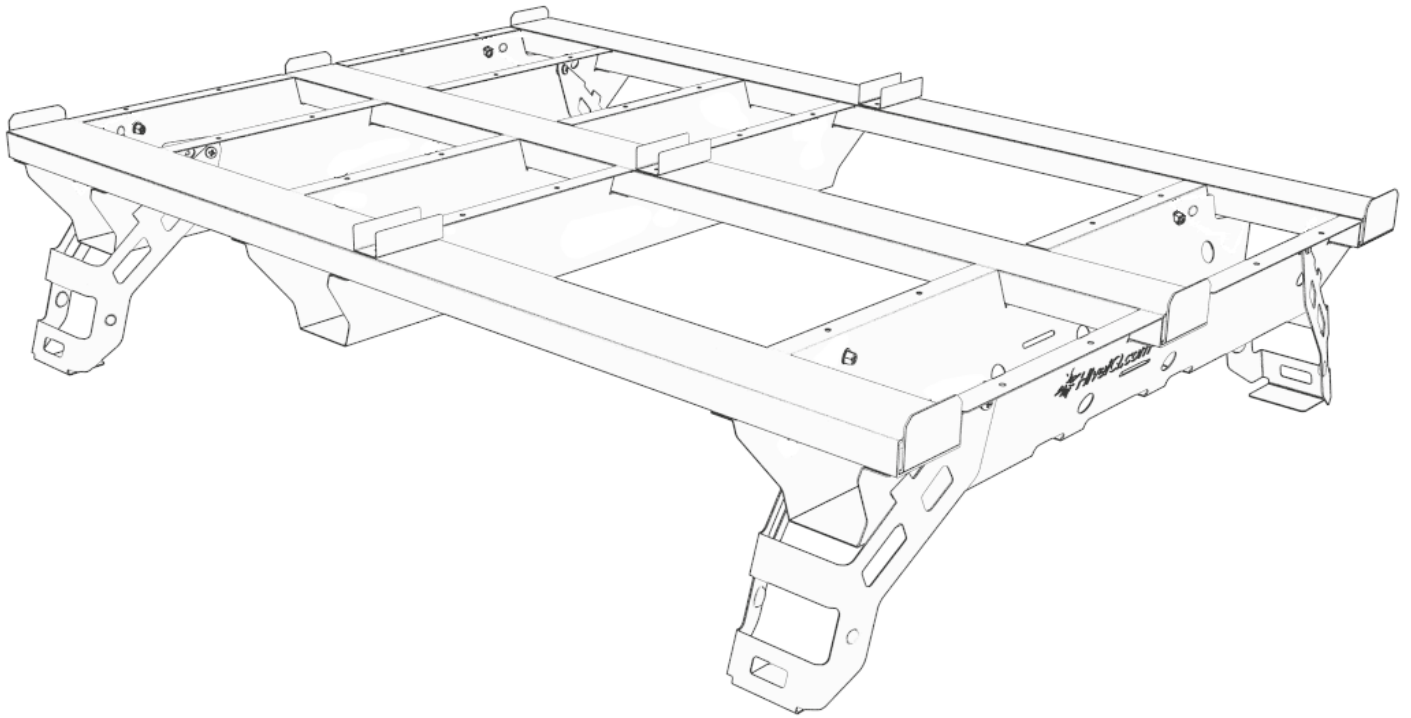

What's in the box?

Item ID	Description	Qty
SP1	Strongback	3
SP2	Outer bases	2
SP3	Inner base	1
SP4	Retainers	6
SP5	Rivet pack	1
SP6	Stand legs	4
SP7	Bolts, Washers & Nuts pack	1
SP8	Separators	3



Scan here to submit a ticket
to the HiveIQ Help Desk



Content © HiveIQ Pty Ltd
HiveIQ Products are protected
by patents, design registrations
and trademarks.



Step by Step

Step 1

Place the strongbacks (SP1) down with the four holes for each base facing upwards. Ensure the centre holes are aligned.

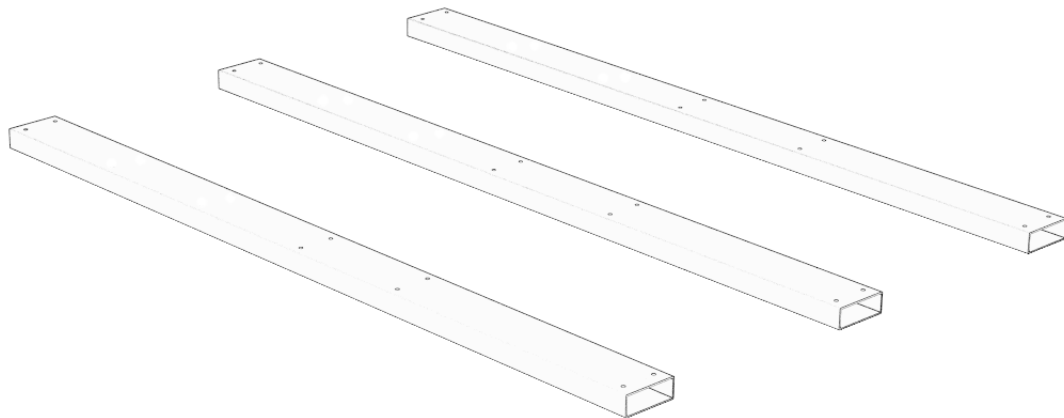

Step 2

Position the two outer bases (SP2) over the strong backs with the HivelQ logo facing outwards and then the middle base (SP3 the one without a logo)

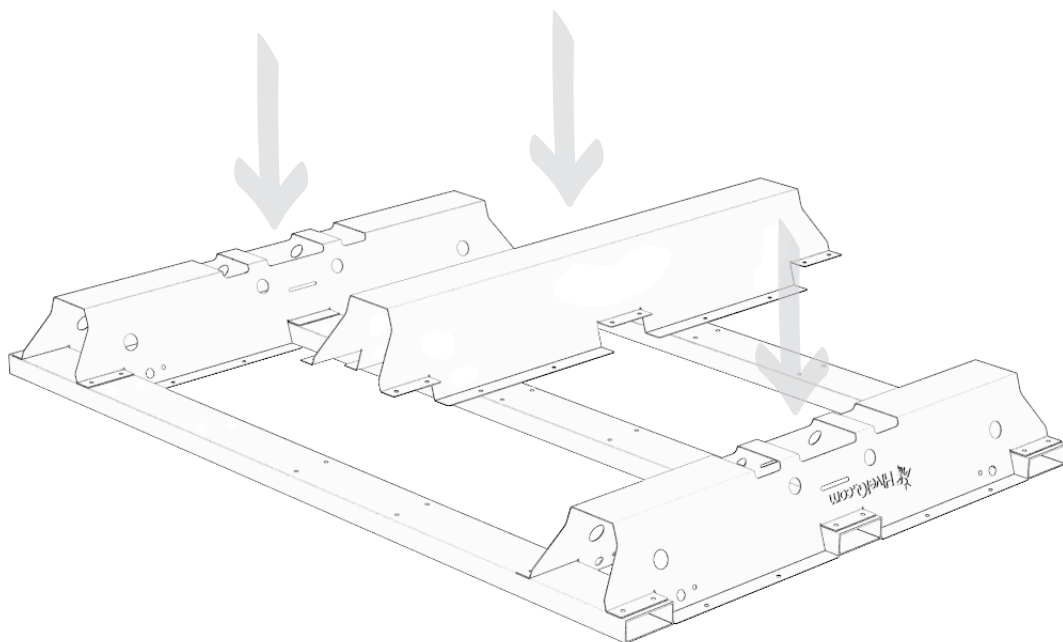

Step 3

Locate the retainers (SP4) at each end of each strongback with the lips facing downward and align the holes for the rivets.

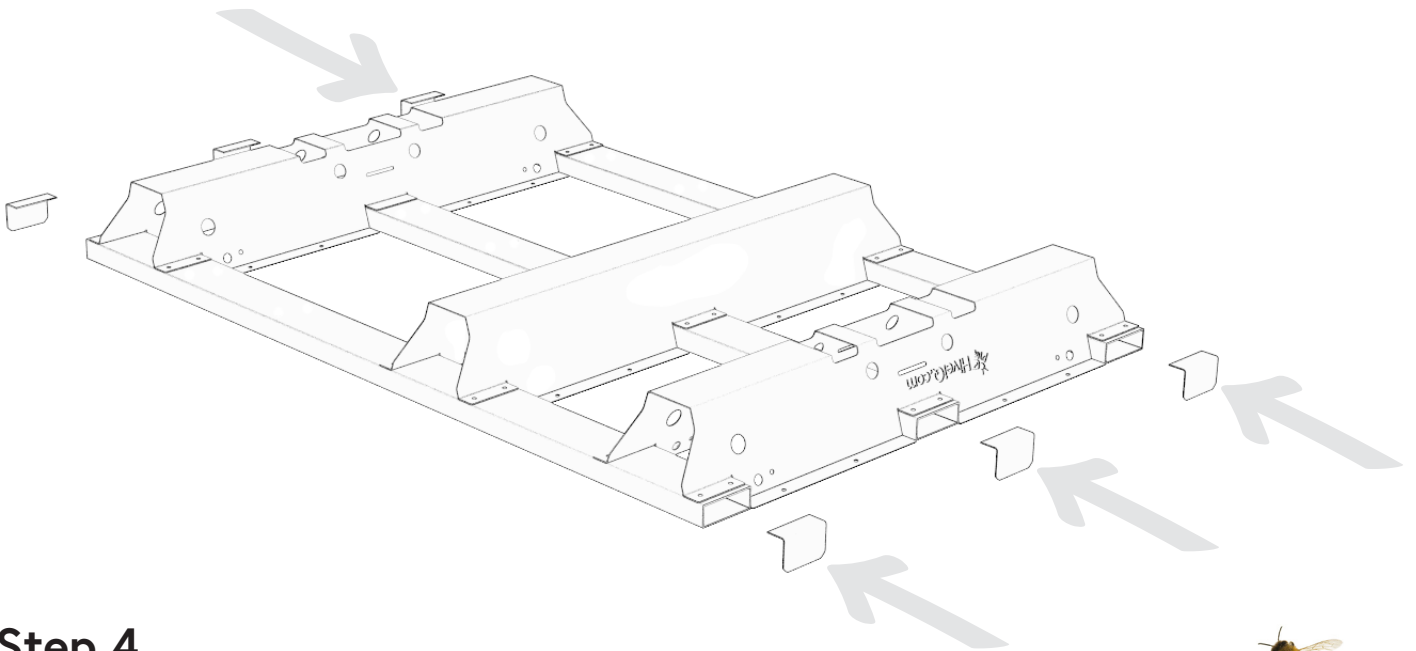

Step 4

Using the rivets (SP5) provided, work your way around the pallet riveting the bases and retainers to the strongbacks whilst ensuring the alignment remains square and true.

The stands are precision engineered, so keep the stand flat and take care to ensure a tight fit of all components.

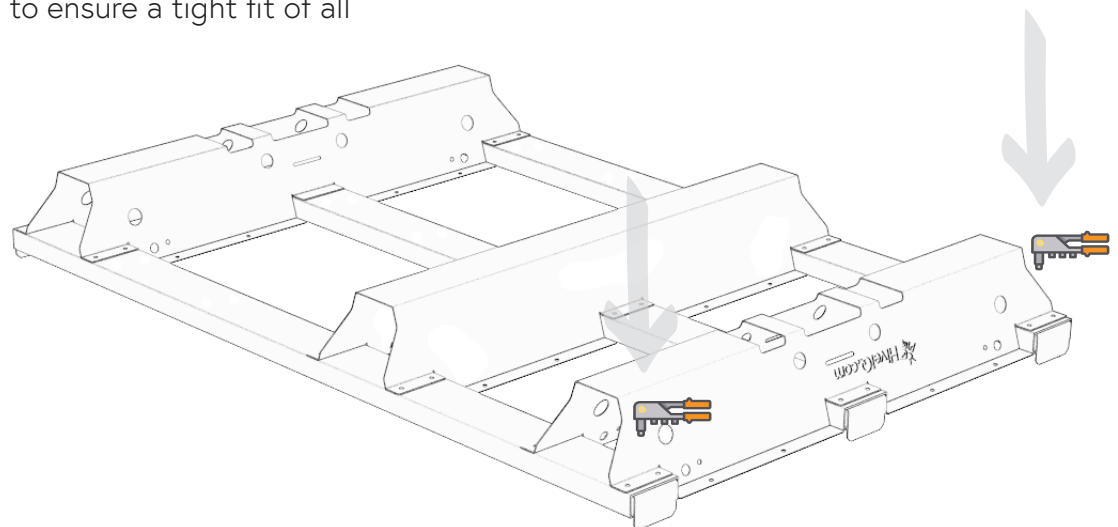

Scan here to submit a ticket to the HivelQ Help Desk



Content © HivelQ Pty Ltd
HivelQ Products are protected by patents, design registrations and trademarks.



Step 5

Put the legs (SP6) in place by pressing them downwards and align the bolt holes in the outer bases.

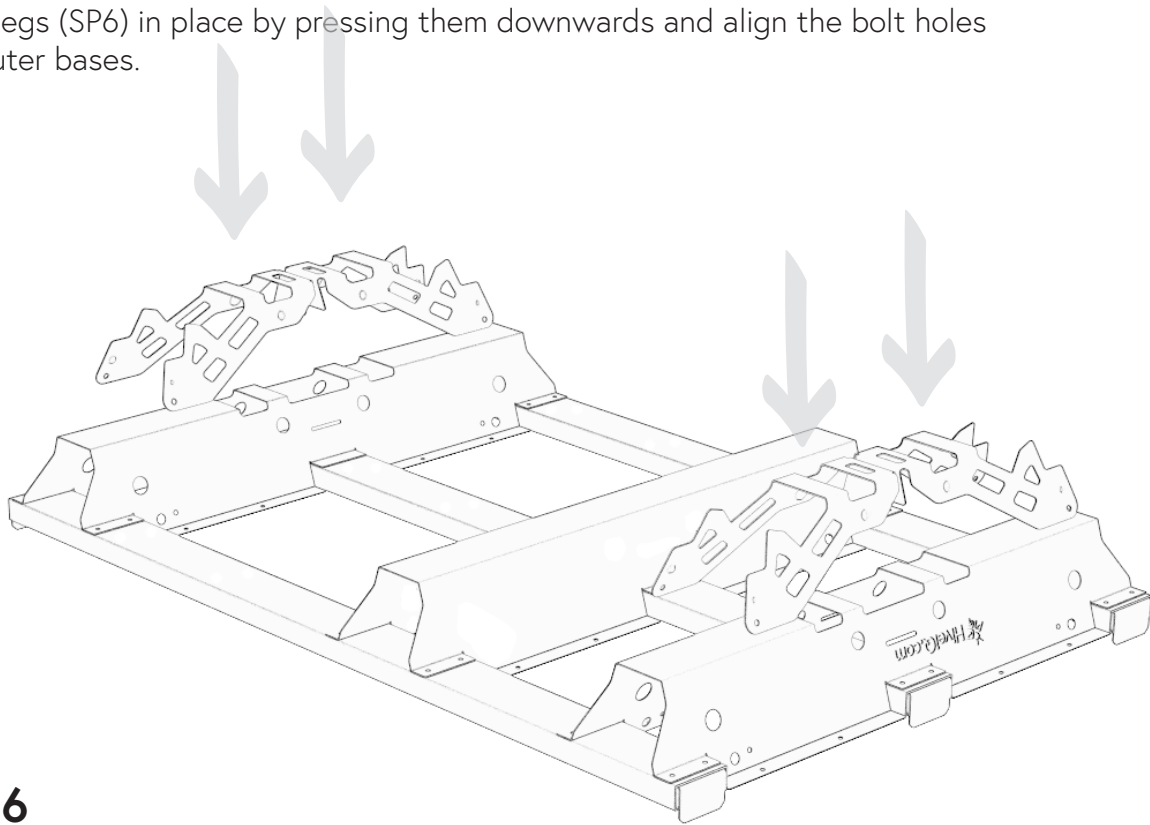

Step 6

Screw fix all four legs to the bases, two bolts per leg on each side of the base. Place a washer on the bolt, push it through and place another washer before the nut on the inside.

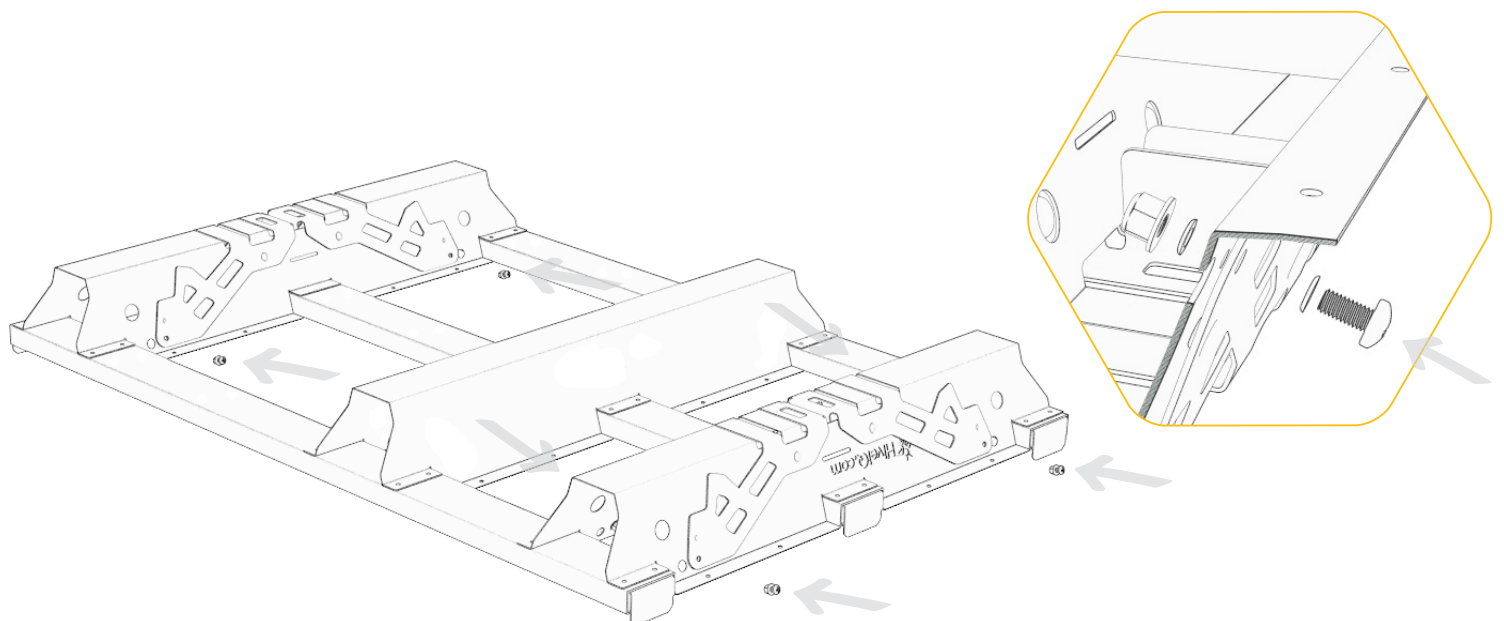

Step 7

Turn the pallet right side up before tightening all the bolts using a spanner and an allen (hex) key. **Do not over tighten the bolts** as it will impede operation of the legs.

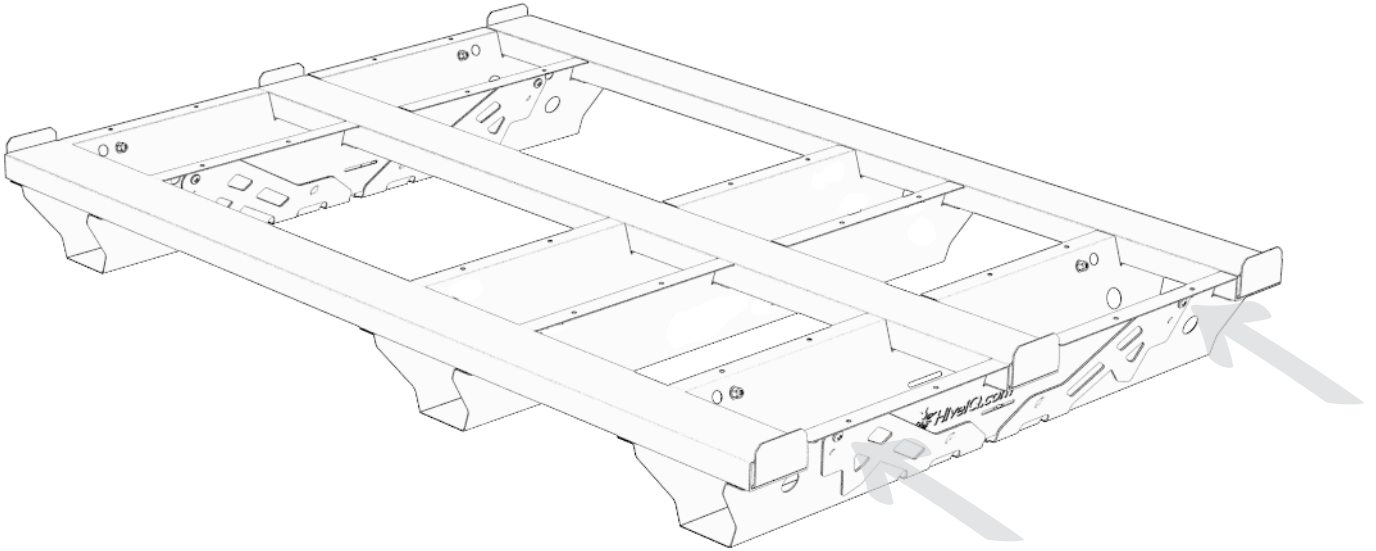
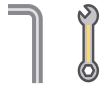

Step 8

Place 3 separator pieces (SP8) down the centre of the pallet using the holes as a guide.

Using a rivet gun, fix the separators to the strongbacks

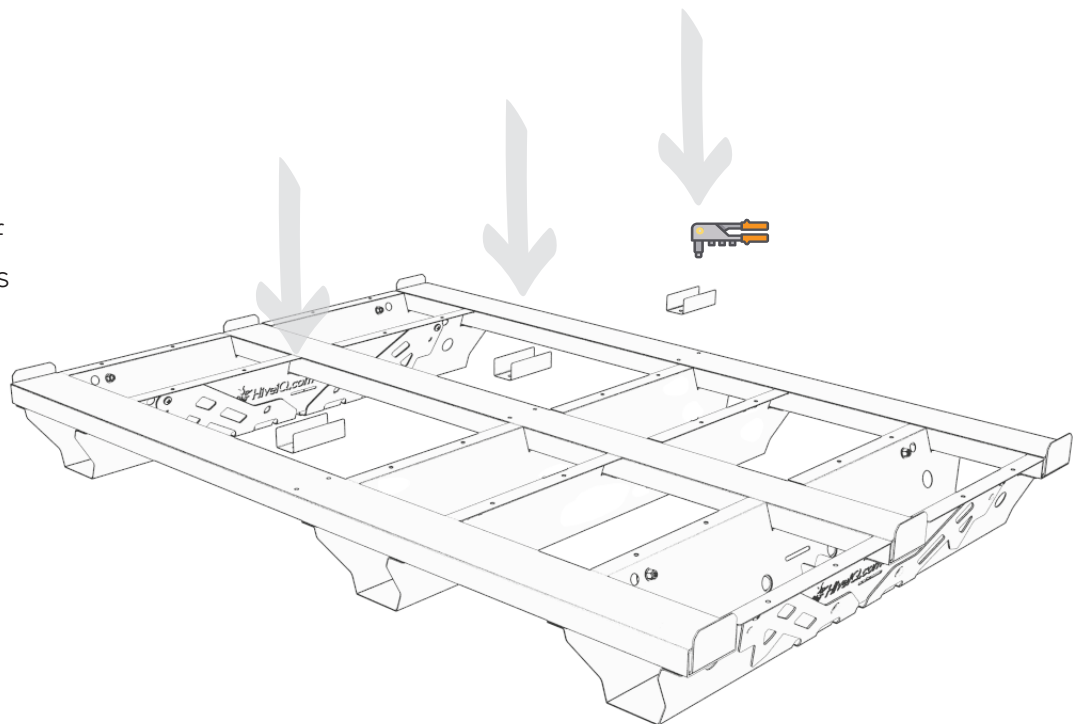

Scan here to submit a ticket to the HivelQ Help Desk



Content © HivelQ Pty Ltd
HivelQ Products are protected by patents, design registrations and trademarks.



To open the legs

Insert your hive tool in the slot below the HivelQ.com logo and twist anti-clockwise to unlock the legs to open. Once unlocked you can open the legs to the full extension, the legs will lock into the open position.

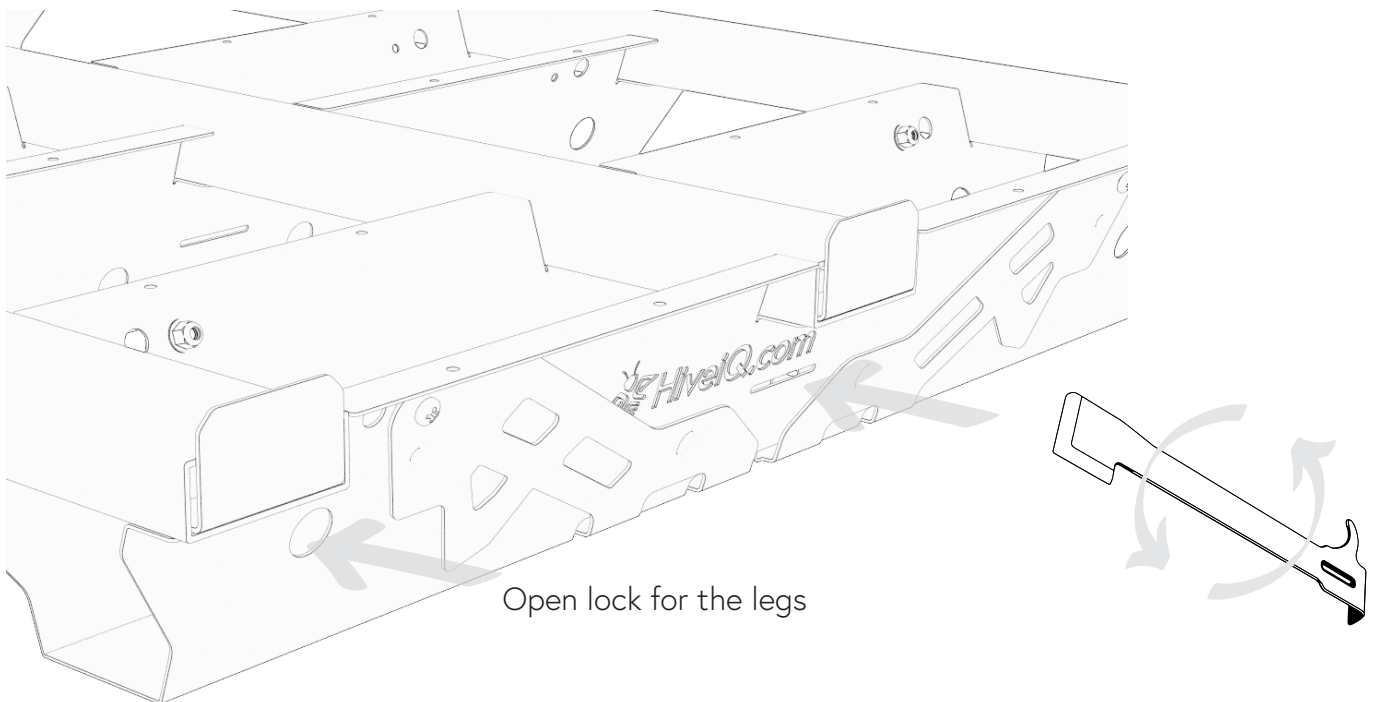

To close the legs

Rotate the legs back to the closed position, they will lock into place. You will need to exert some force to unlock them from the open position.



Palletised beekeeping

Locating hives on the stand

We recommend locating all hives with the entrances facing out from the stand:

- Easier access to the entrance locks and pollen collector latches
- Easier access for the bees
- Easier to smoke the hive through the entrance

In either direction, the hives are held in place with the separators in the middle of the stand and the retainers at each end.



Designed for faster, more efficient professional beekeeping



Scan here to submit a ticket to the HivelQ Help Desk



Content © HivelQ Pty Ltd
HivelQ Products are protected by patents, design registrations and trademarks.



Standard pallet size for forklifts

The HivelQ System is purpose designed for migratory beekeeping and pollination

Our mission from the beginning was to produce a beekeeping system for the commercial, operational and team based requirements of professional beekeeping.



Stack them two or three high and three wide

Optimised for transport to fit on a standard truck - Hives fit 6 wide on pallets fit 3 wide on a truck (6 hives) and designed for fork lift, bobcat or mini loader.





Follow us



Assembly Instructions
Version 1.0

