



for healthy bees

3 Story Beehive Assembly Instructions



The HivelQ Beehive

Better for the bees, better for the environment and better for the beekeeper

The HivelQ beehive is the foundation of the HivelQ beekeeping system.

Constructed with high density Expanded Polystyrene (EPS) for high fusion strength, high quality and precision finish, the hives are designed for usability and long life.



Our hives are dry rot and termite proof, and are engineered to endure the rigours of beekeeping in any environment:

Compatible with industry standard Langstroth frames

Constructed with bee safe and food grade materials

More than 6 times greater insulation than traditional timber hives

Stable hive temperature all year round with no condensation

No wasted energy on thermal management = More productive colonies

Faster assembly = bees on flowers faster and cheaper

More compact and lighter; fits 6 wide on a truck, with half the weight of timber

We trust you will enjoy our products, happy beekeeping from the HivelQ crew



**If you get stuck or have a problem
with with HivelQ products**

Scan here to submit a
ticket to the **HivelQ Help Desk**



Scan here to submit a ticket
to the HivelQ Help Desk



Content © HivelQ Pty Ltd
HivelQ products are protected by
patents, design registrations and
trademarks. See www.hiveiq.com/ip



Tools you need

You will need to supply the following tools and supplies (not included in the kit) to complete the assembly:



Phillips screwdriver or battery screw gun / drill and a standard phillips screwdriver bit



Exterior grade, water based, acrylic paint



Painting gear (roller, paint brush or airless spray gun)



Water resistant, exterior grade general purpose adhesive to secure the Hive Entrance Latches into the Hive Base Body.



Adhesive and caulking gun to install the pressed metal hive top cover onto the lid, we recommend a roof/gutter silicon.



A marker pen, we recommend using a copic pen to label your hives.



ENAMEL



OIL BASED



AEROSOL

Whatever you do, **don't use oil based, enamel type, and aerosol – spray – paints.** These are likely to contain or be based on solvents that will melt the foam.



Painting

Method

The most efficient method of painting your new HivelQ hives will depend on how many you need to paint. For the hobbyist beekeeper with a small number of hives, we recommend a 100mm fluffy paint roller. These are available from any hardware or paint store at a low cost.

Paint Type

Use only water based, exterior grade acrylic paint.

CAUTION: Some new wash and wear paints can damage the polystyrene.



How many coats? Apply a minimum of two coats of paint.

What to Paint?

Hive Base: We recommend that you only paint the surfaces that are exposed to the external elements direct sunlight and weather conditions being the 4 vertical sides and the front landing deck. You do not need to paint the top face areas that are inside the perimeter of the hive body or on the underside of the base because these areas are not exposed to the UV and weather. We recommend avoiding painting interior surfaces of the HivelQ hive to avoid exposing the colony to off gassing of paints inside the hive and to avoid having the hive bodies sticking. Besides, the bees will perform their own painting of the interior of the hive with propolis.

Hive Body: Paint exterior facing surfaces only. Do not paint the inside walls or the top and bottom edges of the hive body that are covered and therefore protected from UV by the box above and below. Optionally, whilst the plastic protective edges are UV rated, we recommend you paint these to provide maximum UV protection.

Hive Top: Paint only the four exterior vertical faces that are exposed to the UV and weather when the Hive Top Cover is installed. Optionally, whilst the plastic protective edges are UV rated, we recommend you paint these to provide maximum UV protection.



Scan here to submit a ticket to the HivelQ Help Desk



Content © HivelQ Pty Ltd
HivelQ products are protected by patents, design registrations and trademarks. See www.hiveiq.com/ip



HiveIQ Hive Base - 9 Frame

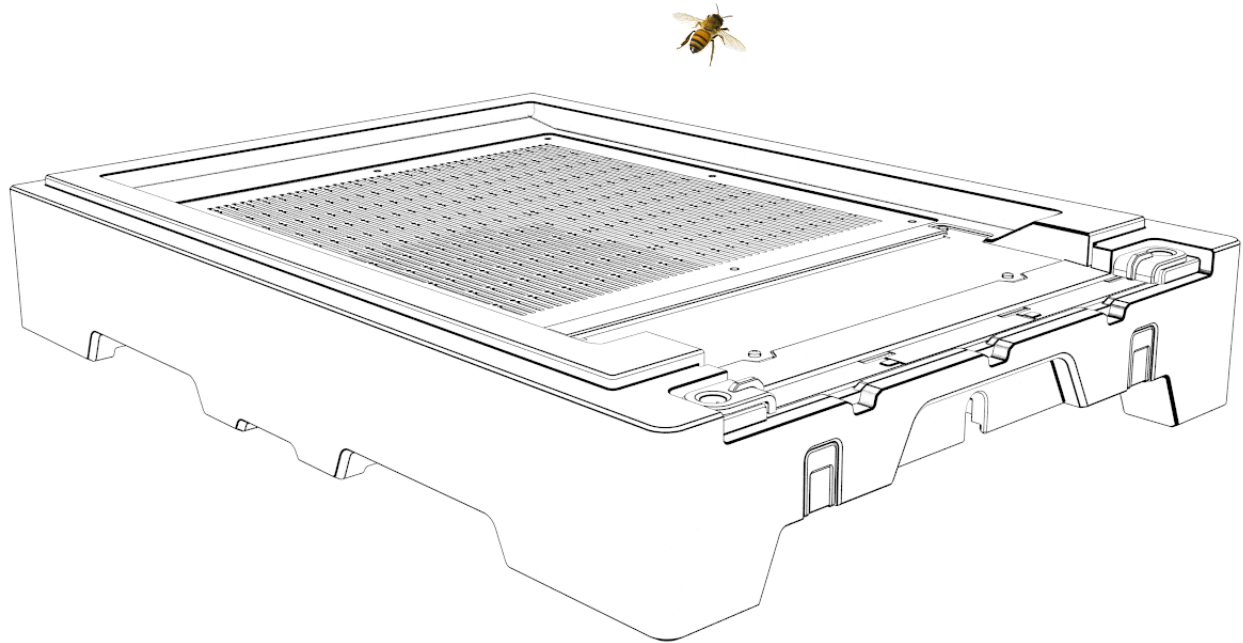

What's in the box?

Item ID	Description	Qty
HB1	9 Frame Hive Base Body	1
HB2	Aluminium Hive Floor (Stamped perforated)	1
HB3	Screw Pack (24 Screws)	1
HB4	Aluminium Pollen Blanking Cover	1
HB5	Hive Entrance (Three Stage)	1
HB6	Hive Entrance Locks	2
HB7	Varroa Board Tracks	2
HB8	NFC Tags (Hive Base)	2



Step by Step

Step 1

Paint the EPS Hive Base Body [HB1]. Painting the hive base body prior to assembly will avoid getting paint on the metal and plastic parts of the hive body. Only paint the external surfaces exposed to the elements as the bees will paint the inside of the hive with propolis if they decide it needs to be covered.

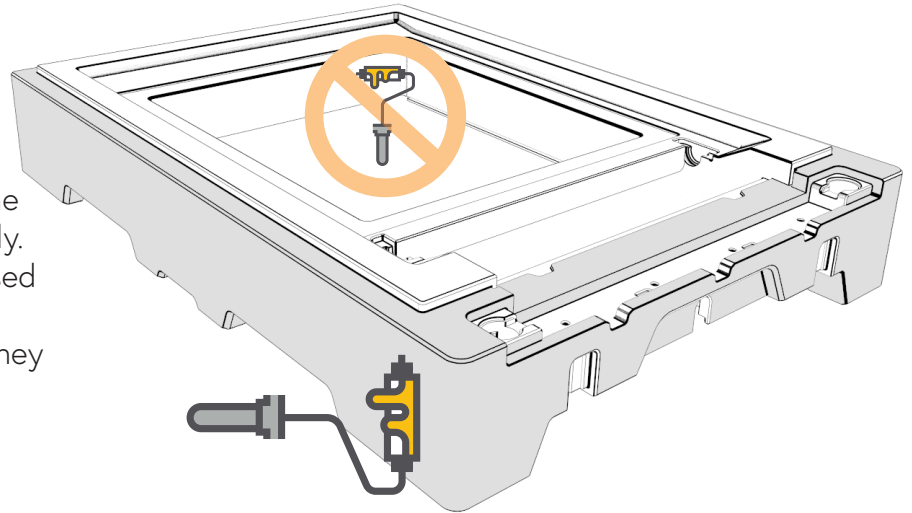

Step 2

Place the Aluminium Hive Floor (Stamped perforated) [HB2] into the recess on the top side of HB1 and screw the floor into place using the 8 self-tapping screws [HB3]. Use a battery powered screw gun or drill to drive the screw carefully into the polystyrene. Take care not to over tighten the screws to avoid them tearing out the EPS around the screw.

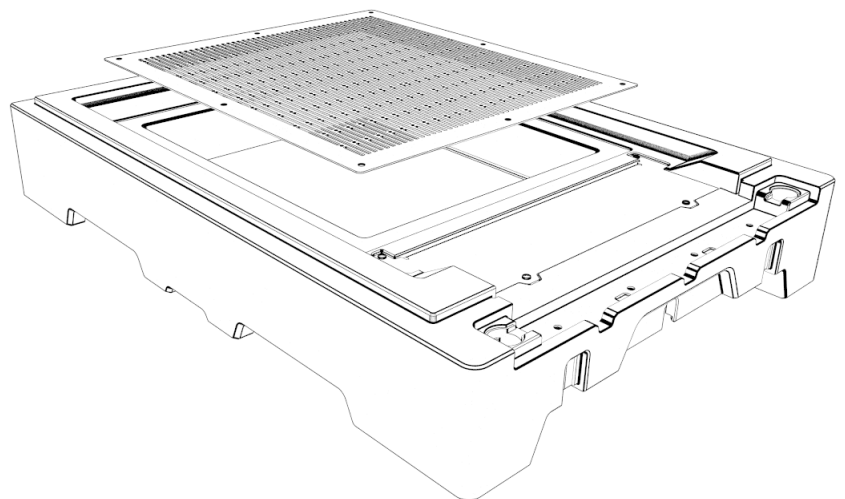

Scan here to submit a ticket to the HivelQ Help Desk



Content © HivelQ Pty Ltd
HivelQ products are protected by patents, design registrations and trademarks. See www.hiveiq.com/ip



Step 3

Place the Aluminium Pollen Blanking Cover [HB4] into the pollen collector recess on the top front of the hive base [HB1] and screw into place using 4 x screws supplied [HB3]

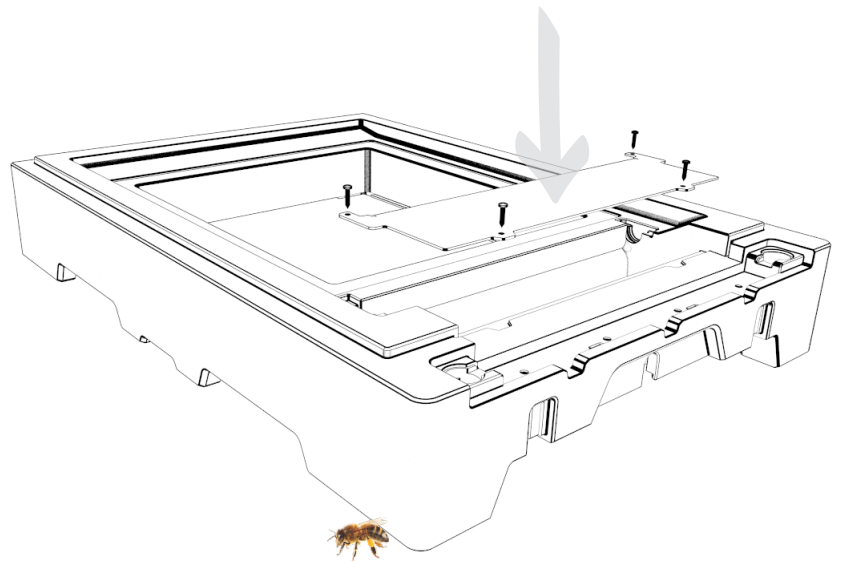

Step 4

Place the hive entrance [HB5] into the hive entrance recess located at the top front of the hive base body [HB1] and screw into place using the 4 self-tapping screws supplied [HB3]

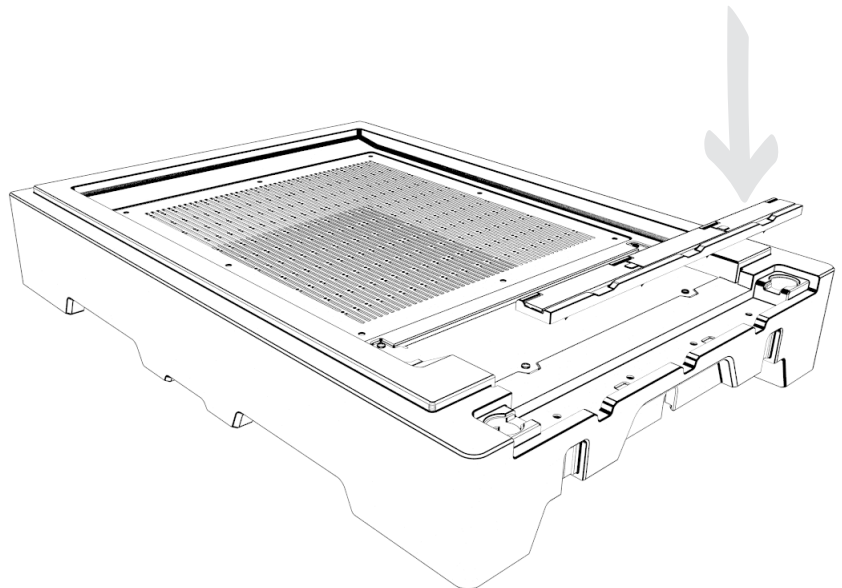

Step 5

Apply a small amount of general purpose exterior grade glue to the outer edge (cylinder surface) of the hive entrance latch [HB6] and insert firmly into the locating holes on the upper front of the hive base body [HB1]. (Be careful not to get adhesive underneath or on the top mating surface of the latch. This can cause it to lock in place) (Retainers/locks should be kept in the 'closed' position when not in use to avoid damage)

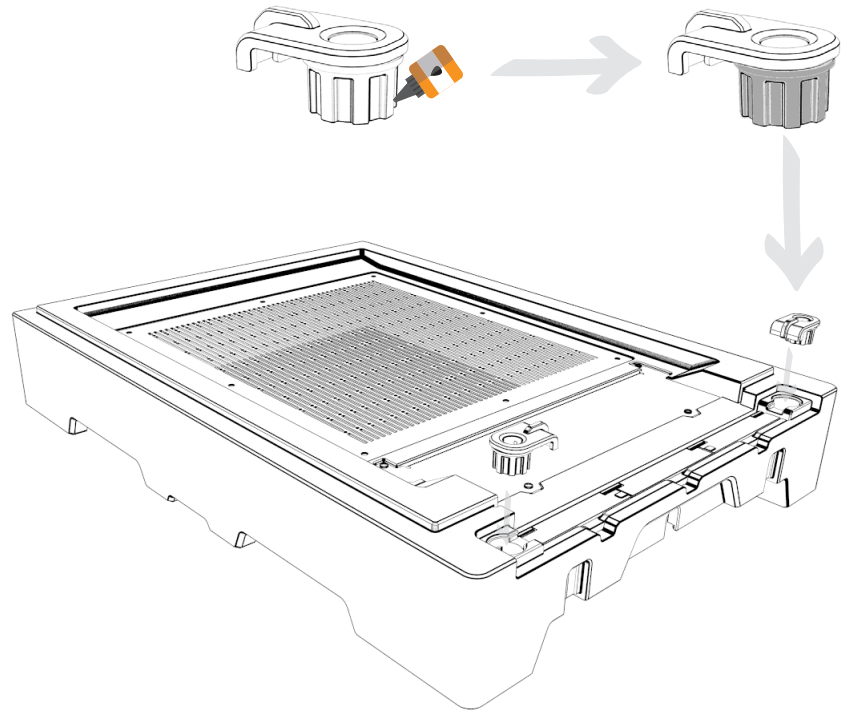

Step 6

Flip the base upside down and place the two varroa board tracks [HB7] into the slots on each side of the hive base [HB1] and screw into place using the 6 self-tapping screw (3 per rail) [HB3].

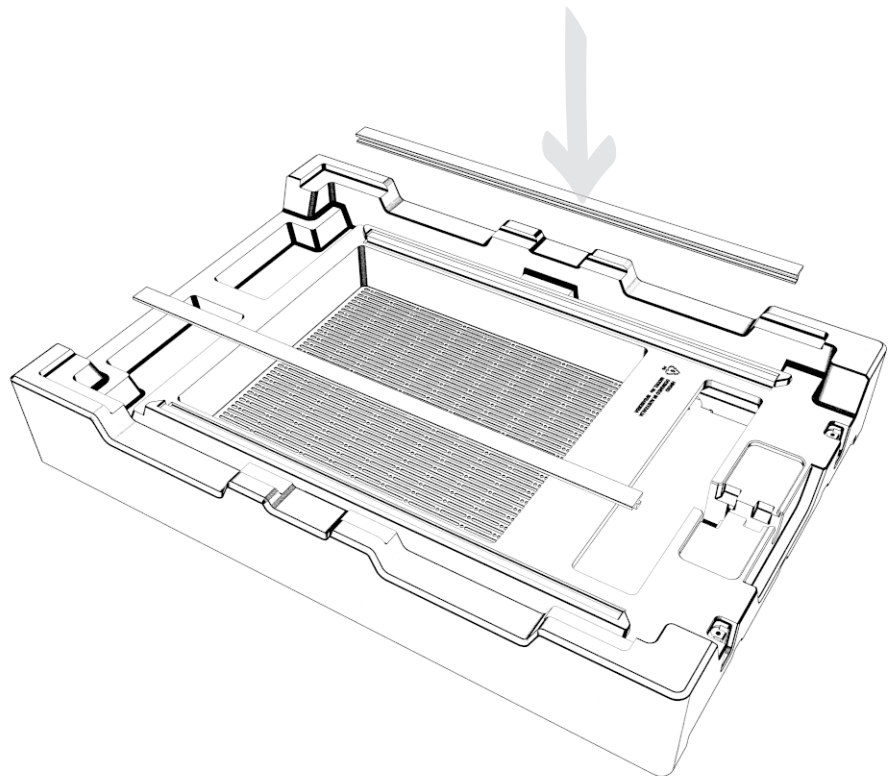

Scan here to submit a ticket
to the HivelQ Help Desk



Content © HivelQ Pty Ltd
HivelQ products are protected by
patents, design registrations and
trademarks. See www.hiveiq.com/ip



Step 7

Insert the two NFC tags [HB8] into the slotted recess on the lower front of the hive base [HB1] and screw into place using the two self-tapping screws (one per tag) [HB3].

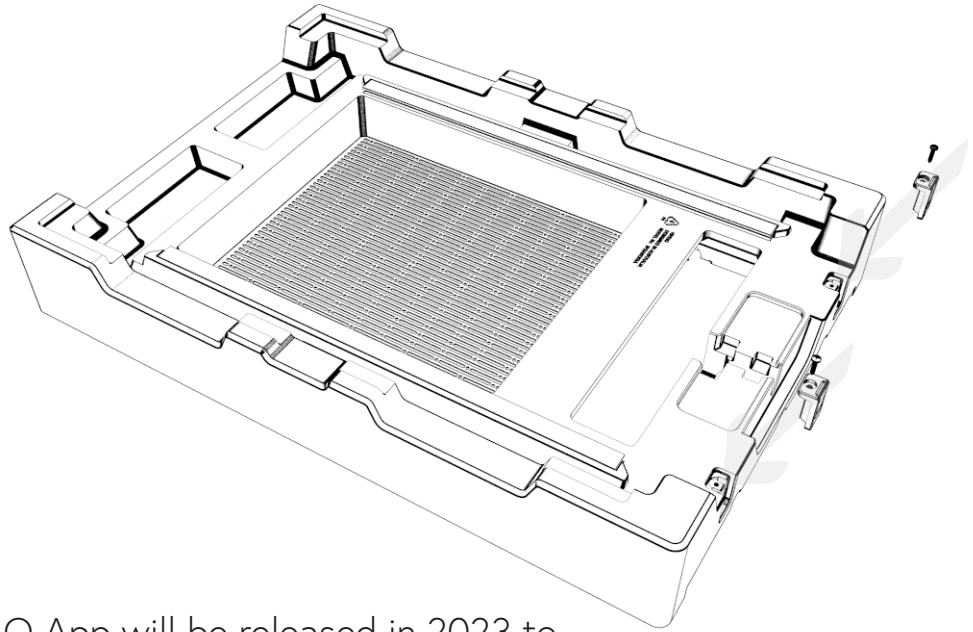
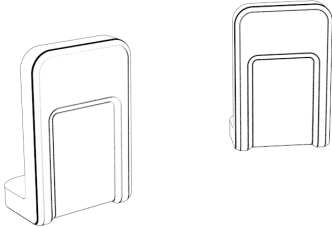

The HivelQ App will be released in 2023 to compliment the HivelQ software and enable NFC scanning... don't lose them!



The HivelQ software is available now

If you don't have a HivelQ account scan here
..or visit: <https://app.hiveiq.com/>

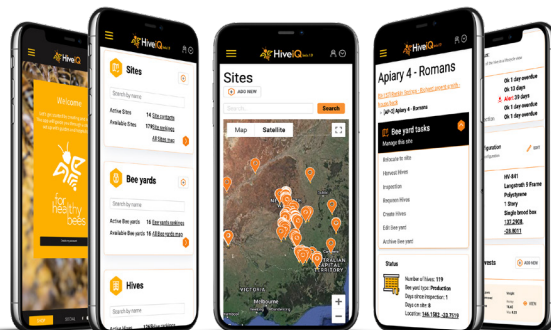

Assembly
Instructions
Version 1.1



HiveIQ Hive Body - 9 Frame

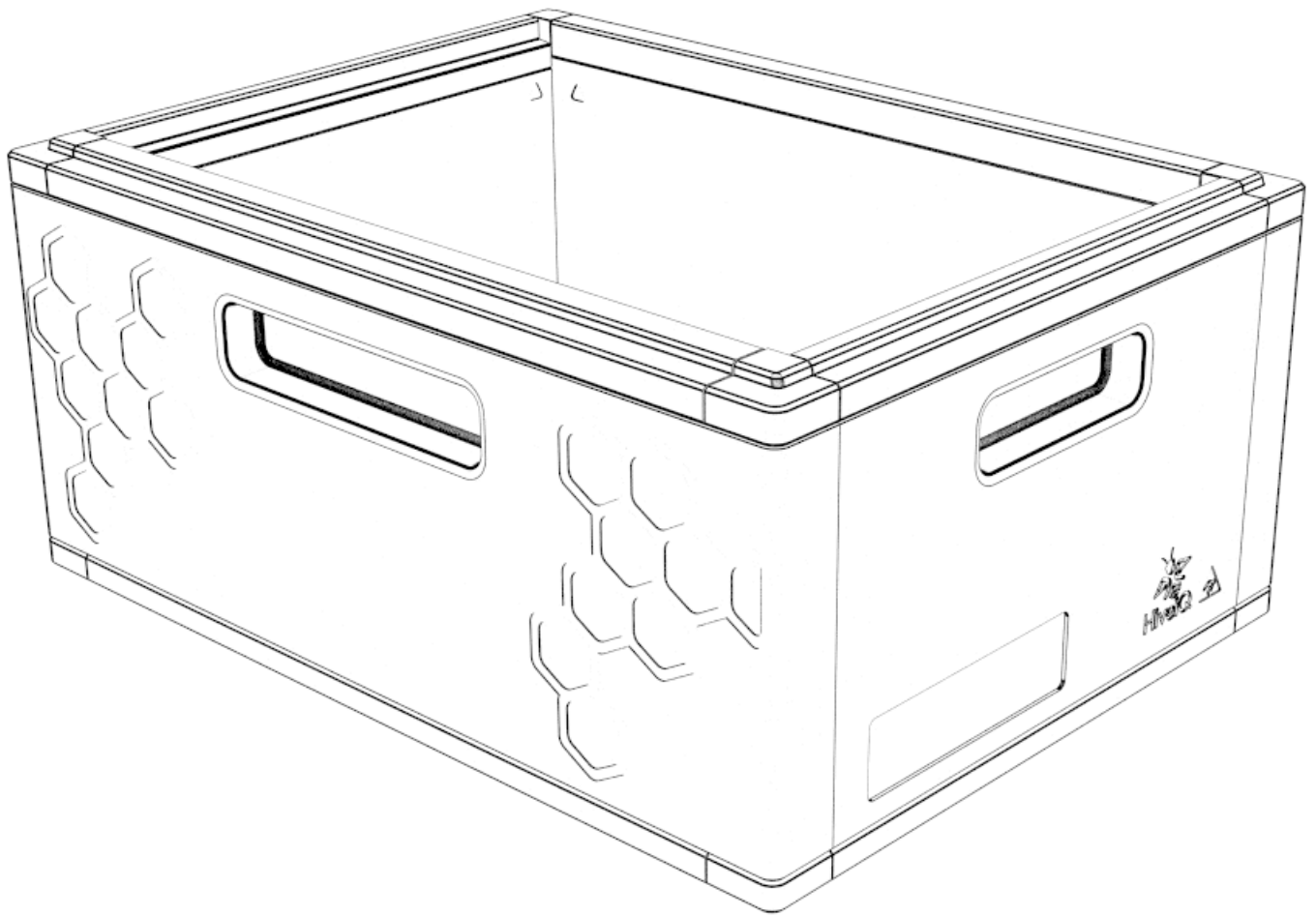

What's in the box?

Item ID	Description	Qty
BO1	EPS Hive Body Side Panel	2
BO2	Top Side Plastic Edge Protection Profile	2
BO3	Bottom Side Plastic Edge Protection Profile	2
BO4	Left Top corner	2
BO5	Right Top corner	2
BO6	Left Bottom corner	2
BO7	Right Bottom corner	2
BO8	EPS Hive Body End Panel	2
BO9	Screws Pack Body – 8 of Screw A	1 (8)
BO10	Top End Plastic Edge Protection Profile	2
BO11	Bottom End Plastic Edge Protection Profile	2



Scan here to submit a ticket
to the HiveIQ Help Desk



Content © HiveIQ Pty Ltd
HiveIQ products are protected by
patents, design registrations and
trademarks. See www.hiveiq.com/ip



Step 1

Slide the upper [BO2] and lower [BO3] plastic edge protection profiles onto the EPS hive body side panels [BO1] to the centre position.

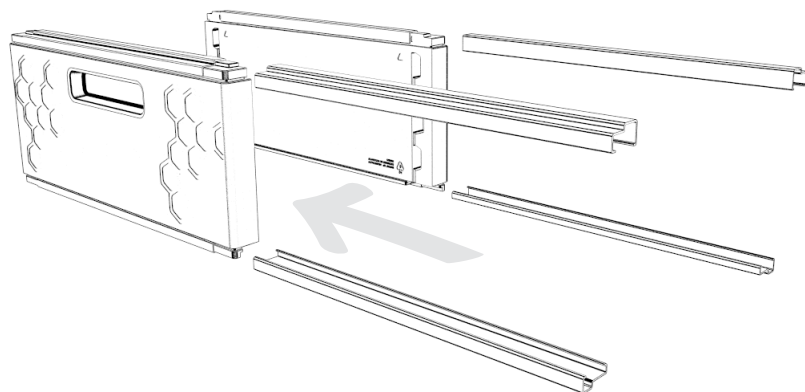

Step 2

Insert the upper and lower, left and right plastic protective corners [BO4,5,6,7]

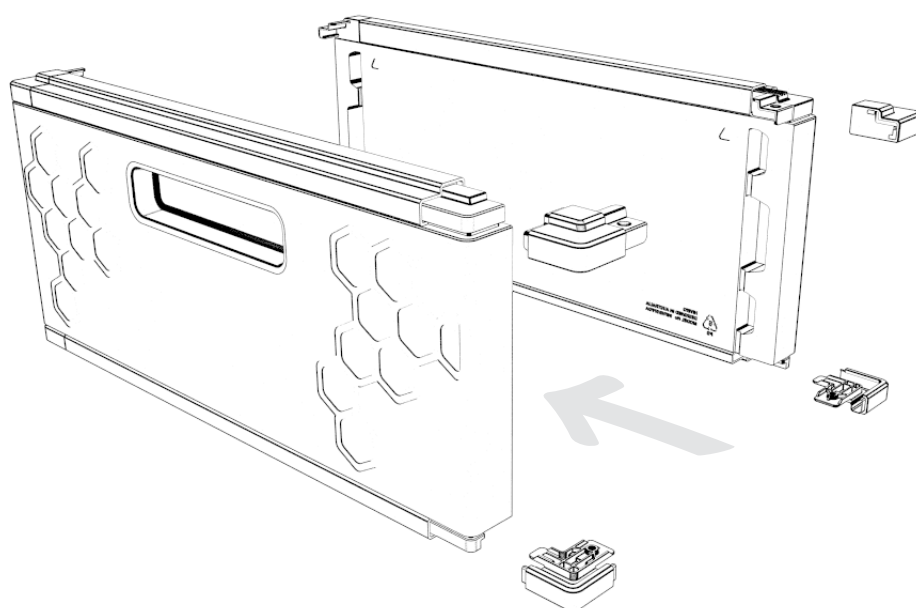

Step 3

Lay the side panel with (with upper and lower side panel and corner) plastic components face down on a table or work bench and press the end panels [BO8] into the three locating holes on the panel. Use the locating arrow on the inside of the side and end panels to ensure correct orientation.

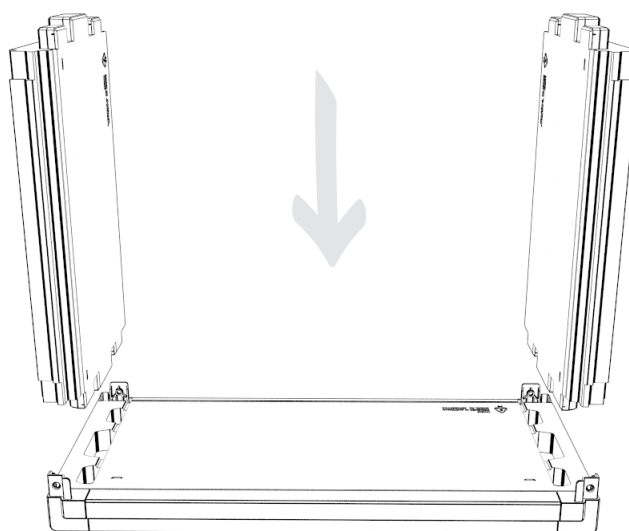

Step 4

Press the second side panel (with upper and lower side panel and corner) plastics installed into the installed end panels until fully engaged.

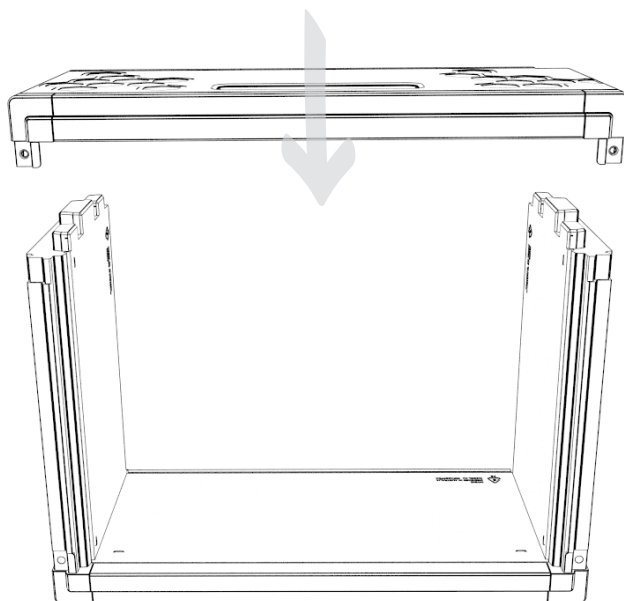

Step 5

Screw [BO9] the eight hive body self-tapping screws into the screw holes of the protecting corners on the upper and lower side of the hive body. Ensure that the side and end panels are fully engaged before inserting screws. It is recommended to have a helper firmly press the joints together while you insert the screws.

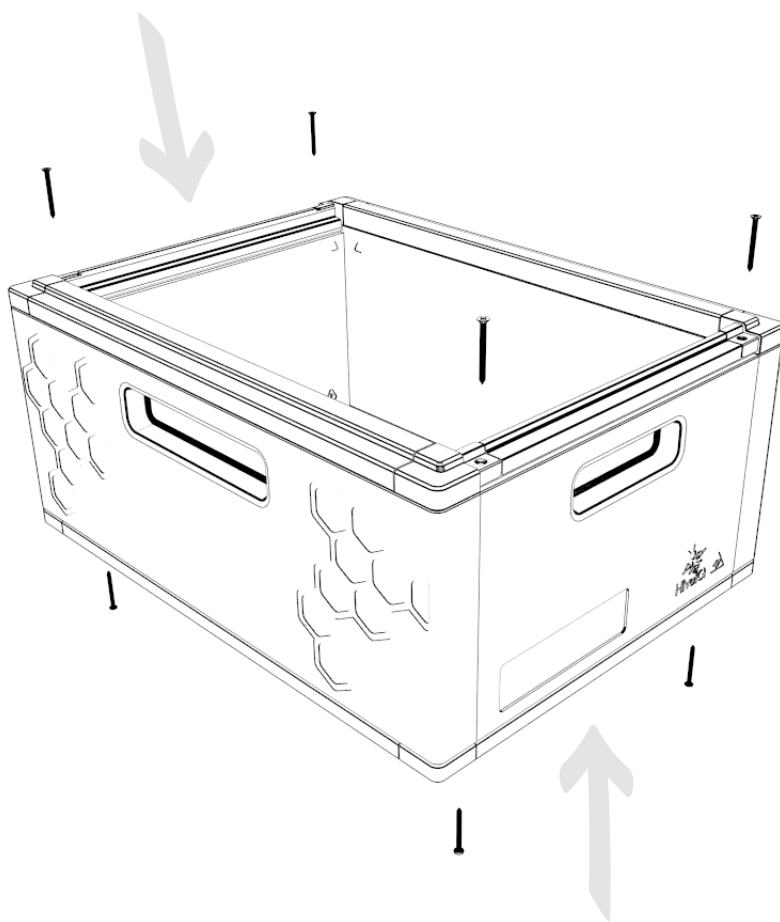

Scan here to submit a ticket to the HivelQ Help Desk



Content © HivelQ Pty Ltd
HivelQ products are protected by patents, design registrations and trademarks. See www.hiveiq.com/ip



Step 6

Position the hive body on a table or work bench with the short side facing you and place the top end panel plastic protective edge [BO10] onto the outer edge of the side panel and firmly snap it over the top edge of the hive body ensuring that the locating edge of the extrusion is locked into the locating groove on the EPS parts. Repeat these steps for the other upper and two lower [BO11] plastic edge protection profiles of the hive body. Note: the lower extrusion requires a little more pressure to snap it into place

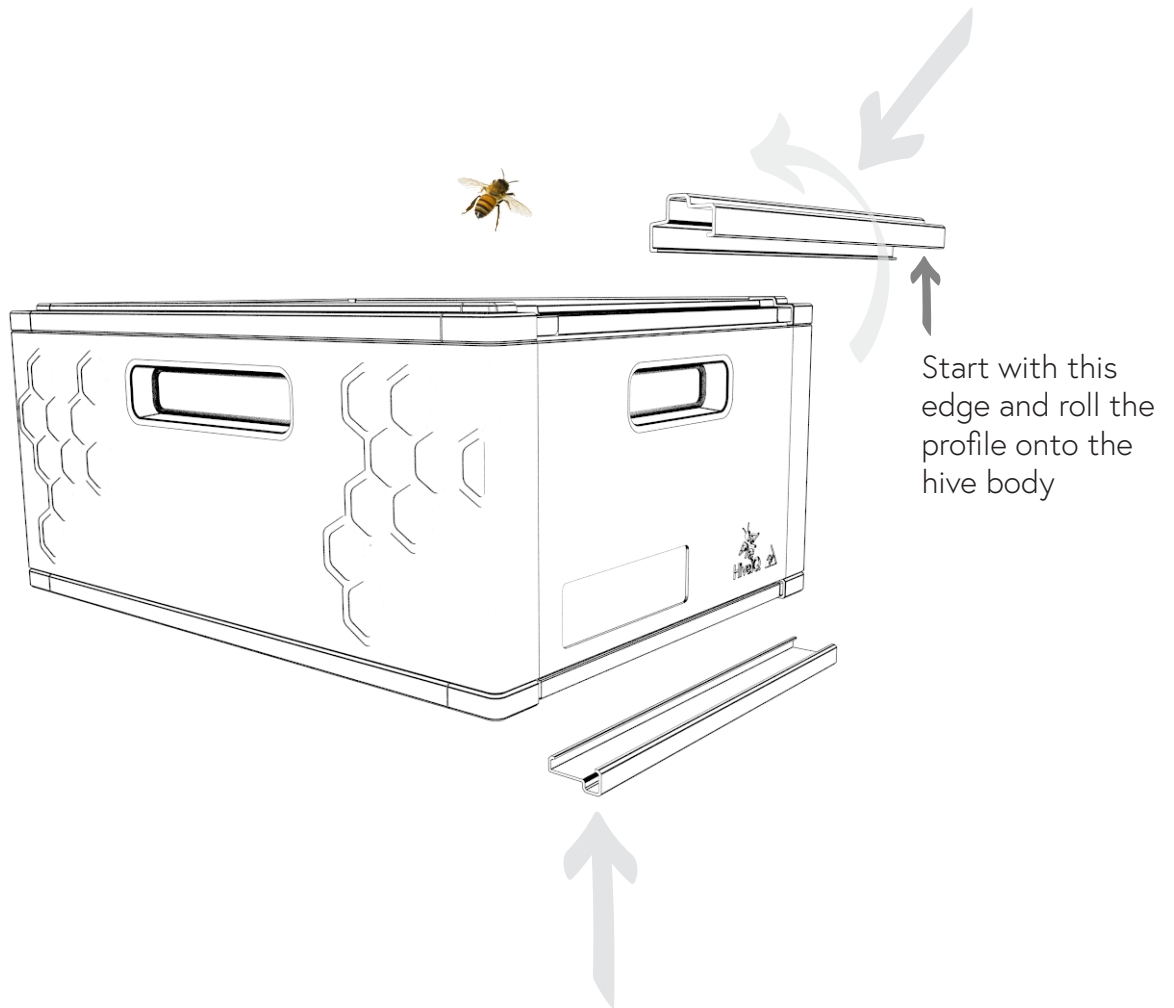

HiveIQ Hive Top

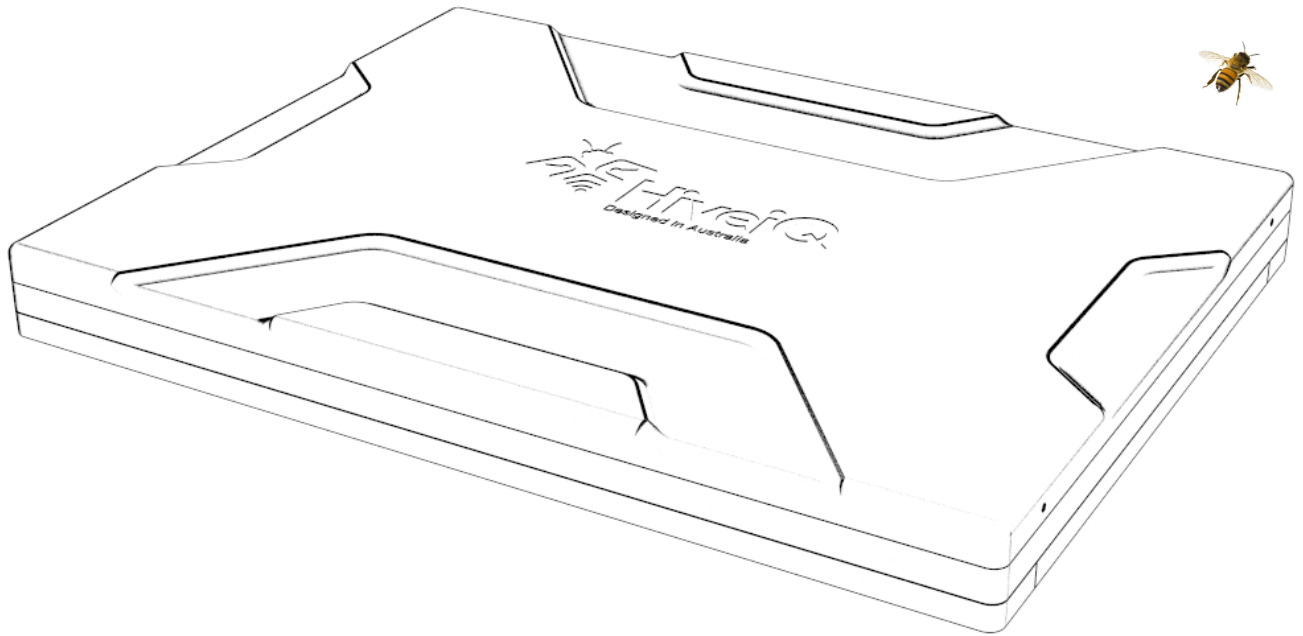

What's in the box?

Item ID	Description	Qty
TO1	EPS Hive Top	1
TO2	Side Plastic Edge Protection Profile	2
TO3	End Side Plastic Edge Protection Profile	2
TO4	Screw Pack Lid – 14 of Screw B	1 (14)
TO5	Metal Cover	1



Scan here to submit a ticket
to the HiveIQ Help Desk



Content © HiveIQ Pty Ltd
HiveIQ products are protected by
patents, design registrations and
trademarks. See www.hiveiq.com/ip



Step 1

Place the EPS Hive Top [TO1] face down on a table or workbench and firmly press the two side [TO2] plastic protective edge parts into the locating grooves on EPS Hive Top.

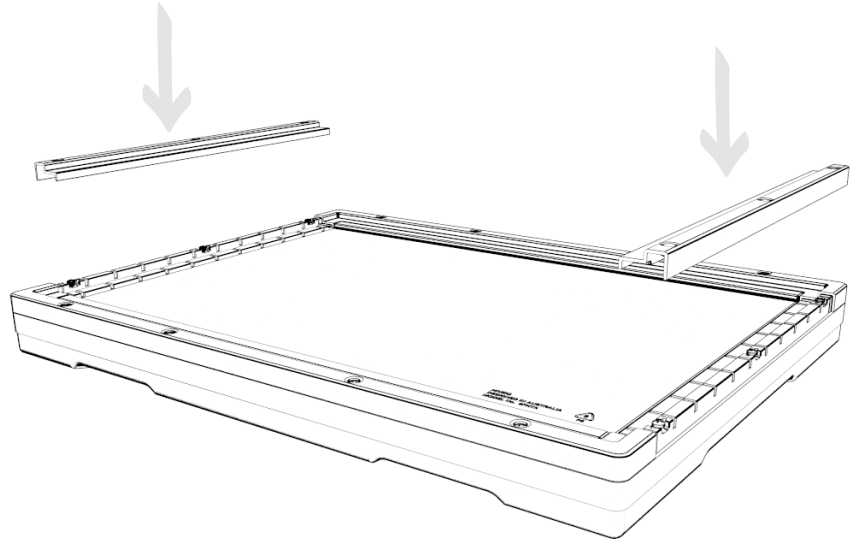

Step 2

Press the two plastic end protective edge profiles [TO3] into the locating grooves on the EPS Hive Top [TO1].

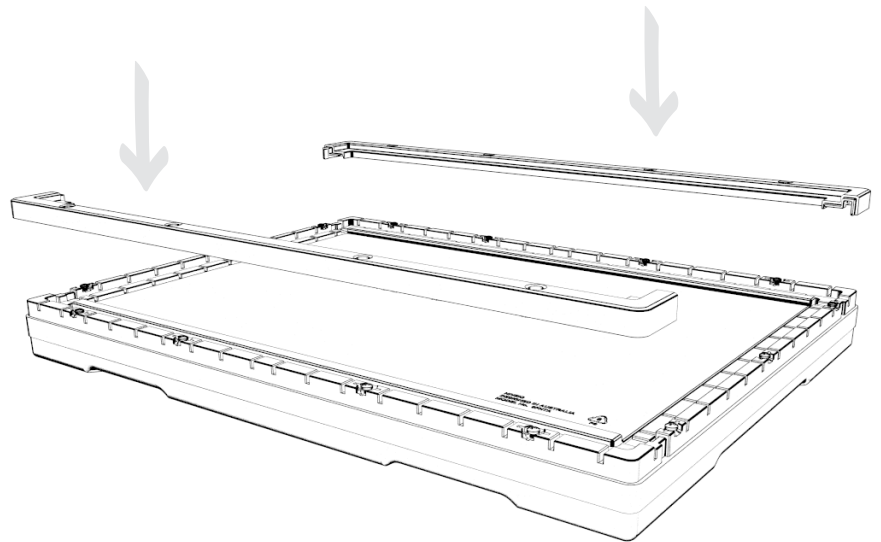

Step 3

Screw in the 14 x self-tapping screws [TO4] through the holes in the plastic parts and into the EPS. Take care not to over tighten the screw to avoid the screw tearing the EPS and becoming loose.

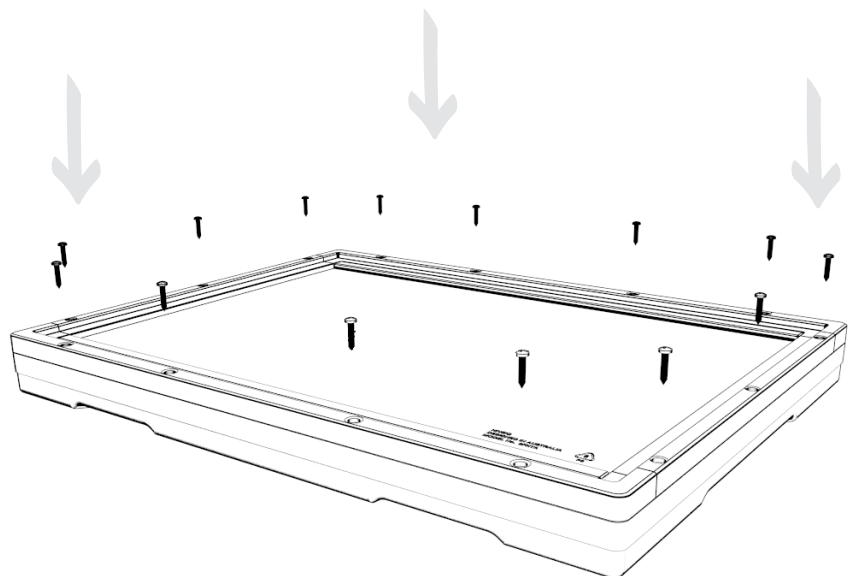

Step 4

Position the hive top in the face (top) up position and apply a construction grade adhesive in several locations. The adhesive we recommend is a roof/gutter silicon.

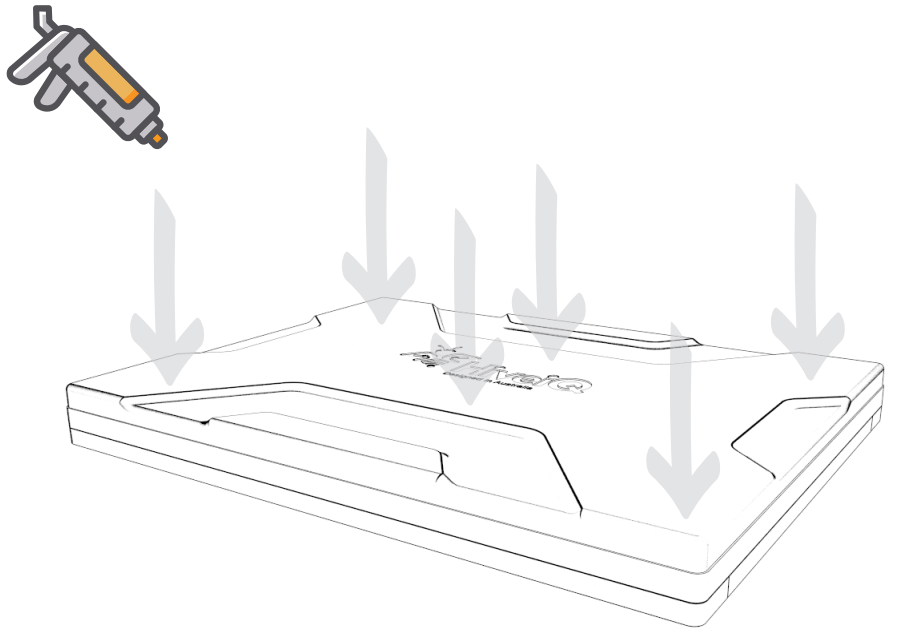

Step 5

Install the pressed metal hive top cover [TO5] firmly onto the hive top until fully engaged. Keep pressure on until the adhesive has set.

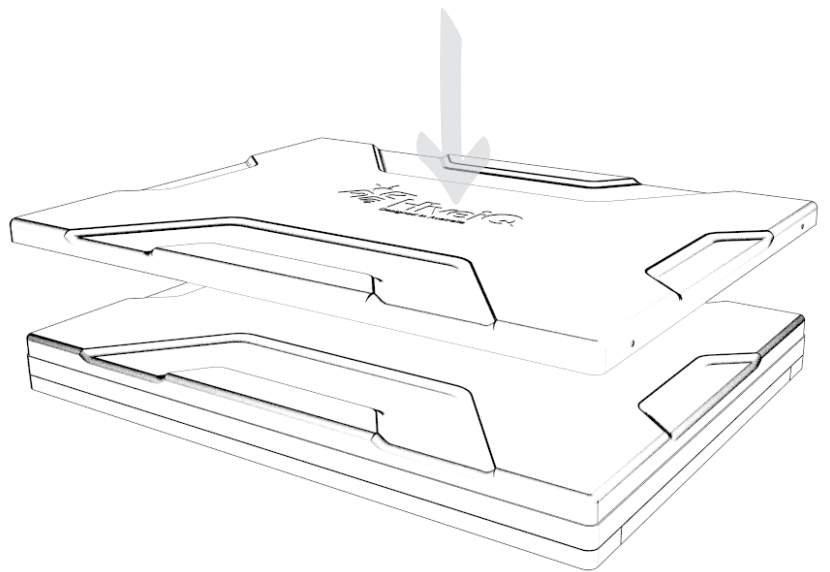

Scan here to submit a ticket
to the HivelQ Help Desk



Content © HivelQ Pty Ltd
HivelQ products are protected by
patents, design registrations and
trademarks. See www.hiveiq.com/ip



How to label your hives and enter them into your software...

If you don't have a HivelQ account scan here
..or visit: <https://app.hiveiq.com/>



You can use the HivelQ beeta software for hobbyist or professional beekeeping. Our beeta program is free through to 1 July 2023, after that it will be \$5 per month with additional charges for some professional modules. All of your data and content will be there if you choose to keep using our software. What we ask in return is that you help us help you with better software for beekeepers. When using the software, you will notice feedback icons and we'd really appreciate your feedback on our beeta 1.0 release to help us make the best software for beekeepers.

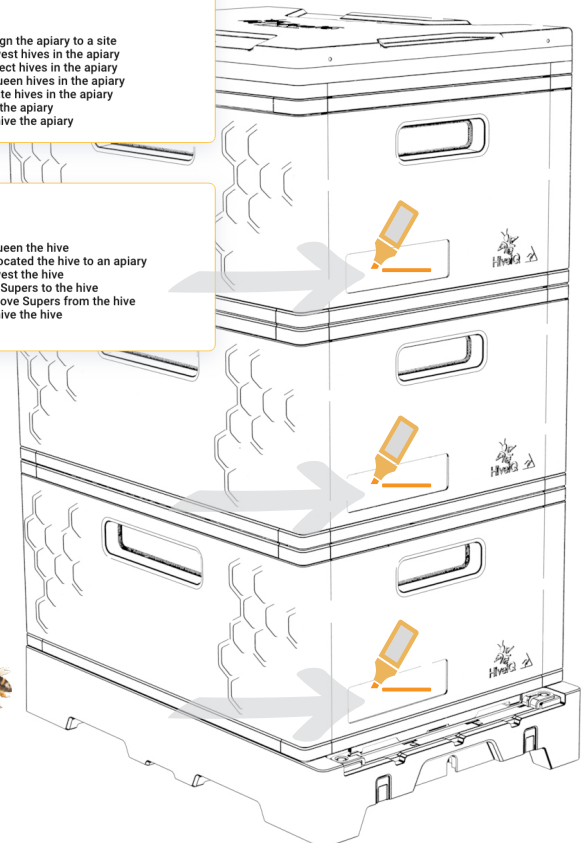
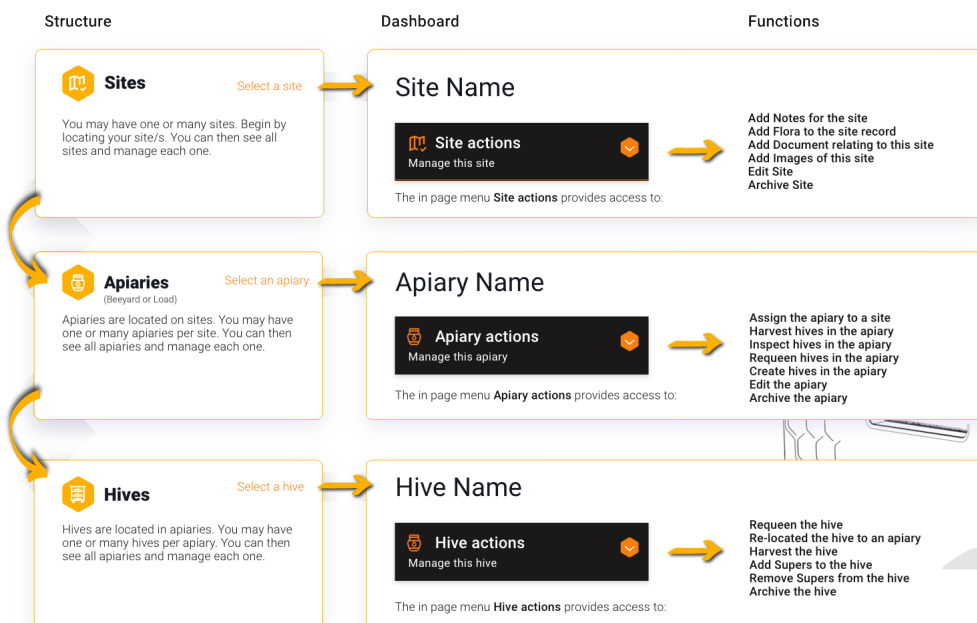

Associate your hive with the software

You can enter your hive identifiers into the software, at the hive level, to track inspections, honey production and many more beekeeping activities.



Assembly Instructions
Version 1.1



A simpler nucleus hive...

A nucleus hive (nuc hive)

is a small hive with a typical capacity of 4, 5 and 6 frames.

Nuc hives are predominantly used by beekeepers and queen bee breeders to split off new smaller colonies, and for hatching and mating new queens.

The HivelQ 4 frame conversion kit

provides a considerably lower cost solution for beekeepers and simplifies the management and storage of what can be a considerable quantity of equipment and material for larger commercial operators. Stored hive equipment such as nuc hives and frames require specialised cool room storage or chemical treatments to repel pests such as wax moth and small hive beetles. The HivelQ solution removes this problem.

The kit consists of a 30mm thick food-grade laminated foam divider board and an entrance divider/guide. The divider board is made from strong, light weight closed cell foam to prevent moisture absorption, and is laminated with a high strength food grade plastic preventing pest and bee chewing damage.



The laminated coating also minimizes damage from rough handling.

The conversion kit's flexibility enables the hive to be quickly converted back to a 9-frame production hive when the nuc configuration is no longer required.



Scan here to submit a ticket to the HivelQ Help Desk



Content © HivelQ Pty Ltd
HivelQ products are protected by patents, design registrations and trademarks. See www.hiveiq.com/ip



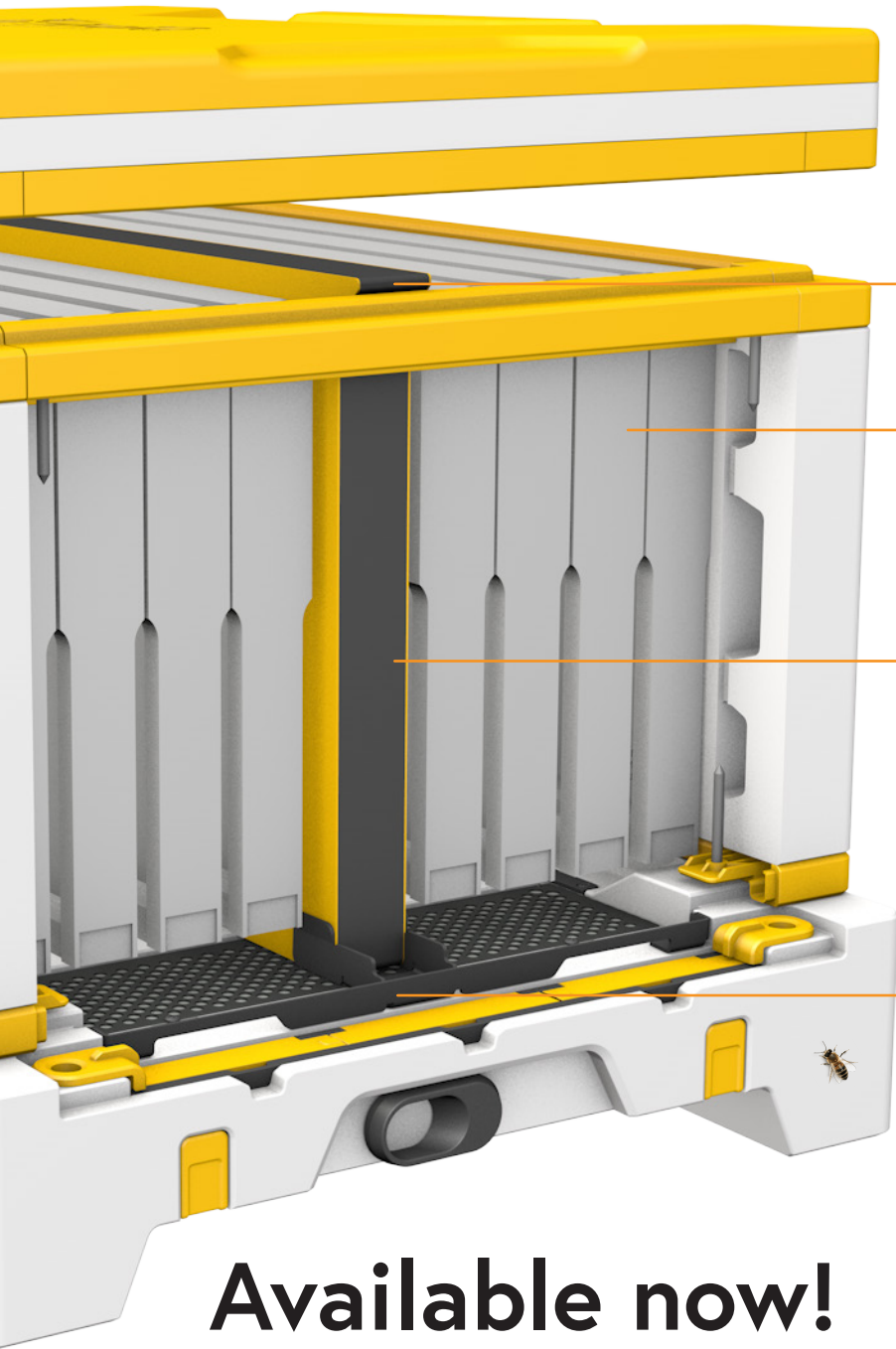

Snug fit to the underside of the hive body lid, ends and across the hive floor eliminating any possibility for bees to pass between hives

Capacity for four Langstroth frames each side of the divider board

30mm Divider Board made from laminated strong, light weight closed cell foam

Entrance Divider / Guide made from anodised aluminium, designed to segregate/isolate the entrances of each colony, and provides a location guide to secure the divider board in the correct position.

Available now!

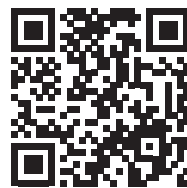

Scan here to visit the HivelQ online shop





Follow us



Assembly Instructions 
Version 1.0