

BUILT TOUGH
FROM THE BOTTOM UP



STERLING
CONCRETE & MASONRY WHEELBARROWS

Assembly Instructions & Parts Breakdown





QUALITY TO THE CORE.

STERLING® WHEELBARROW DUAL-WHEEL

Tray & Frame: Insert two 3-1/2" carriage bolts through tray bottom rear holes and two 5-1/2" carriage bolts through tray bottom front holes. Place wedges with thicker ends forward - over bolts. Place handles with rounded ends to rear over bolts with flat sides on the wedges. Place legs over bolts with welded cross brace to rear. Place wood cross brace over front bolts. Place metal cross bar over rear bolts. Apply nuts to rear bolts and washers and nuts to front bolts.

Tray Support Plate, Axle, Tray Braces: Insert two 1" carriage bolts through upper front tray holes. Place tray support plate over bolts. Place one end of each brace over each bolt. Apply Nuts. Position holes in tray braces over 1st holes in frame. Insert two 3" cap bolts through tray braces, frame and wheelguard. Fasten dual axle assembly on frame with four 2-3/4" carriage bolts. Apply nuts.

Wheel Assembly: If bearings are not inserted in hubs, drive one into each end of hub.

Wheel to Axle Assembly: Put one washer inside, followed by wheel, followed by washer, followed by cotter pin. If extra washers are needed, add extra washers inside of wheel.

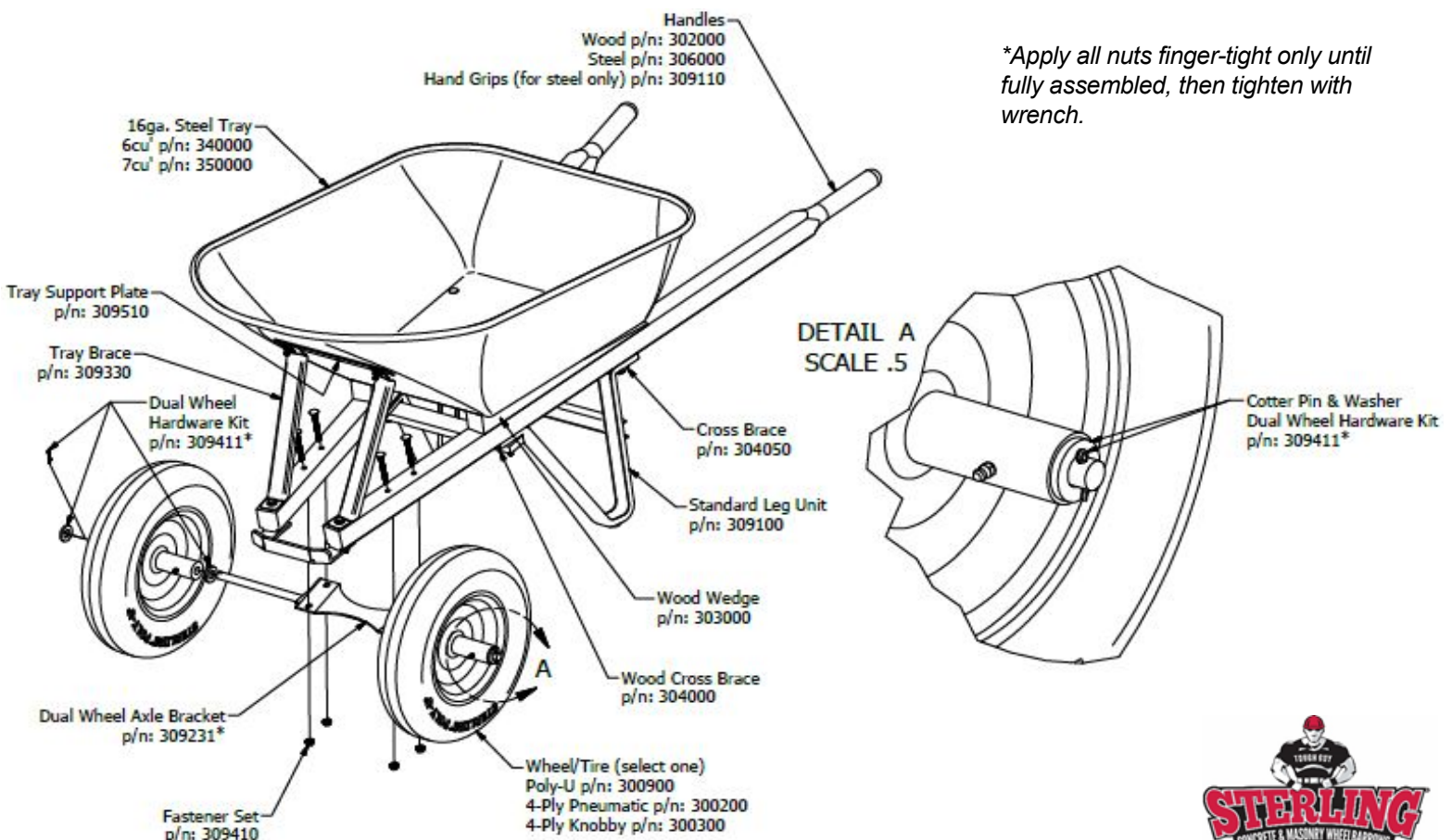



QUALITY TO THE CORE.

STERLING® WHEELBARROW SINGLE-WHEEL

Tray & Frame: Insert two 3-1/2" carriage bolts through tray bottom rear holes and two 5-1/2" carriage bolts through tray bottom front holes. Place wedges with thicker ends forward - over bolts. Place handles with rounded ends to rear over bolts with flat sides on the wedges. Place legs over bolts with welded cross brace to rear. Place wood cross brace over front bolts. Place metal cross bar over rear bolts. Apply nuts to rear bolts and washers and nuts to front bolts.

Tray Support Plate, Tray Braces: Insert two 1" carriage bolts through upper front tray holes. Place tray support plate over bolts. Place one end of each brace over each bolt. Apply Nuts. Position holes in tray braces over 1st holes in frame. Insert two 3" cap bolts through tray braces, frame and wheelguard.

Wheel Assembly: If bearings are not inserted in hubs, drive one into each end of hub.

Wheel to Axle Assembly: Put one washer inside, followed by wheel, followed by washer, followed by cotter pin. *If extra washers are needed, add extra washers inside of wheel.*

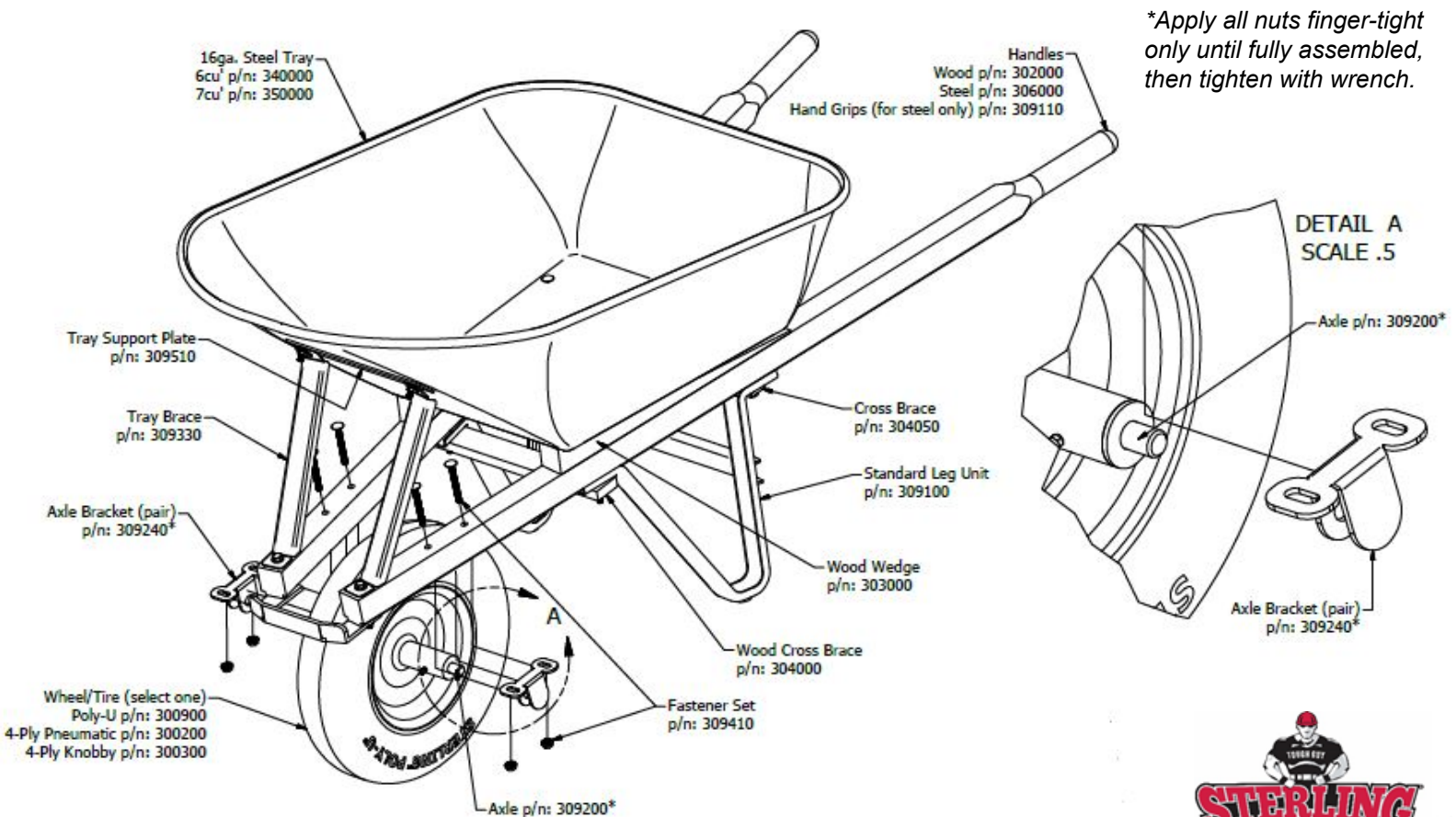



QUALITY TO THE CORE.

STERLING® WHEELBARROW

Wood Handle / PolyTray

6c' & 8c'



Fastener Set

(2)	5-1/2"	Carriage Bolts	p/n: 024-355
(2)	3-1/2"	Carriage Bolts	p/n: 024-333
(4)	2-3/4"	Carriage Bolts Hex	p/n: 024-327
(2)	3"	Head Cap Bolts	p/n: 020-330
(2)	1"	Carriage Bolts Flat	p/n: 020-311
(2)	5/16"	Washer	p/n: 041-131
(12)	5/16"	Flange Nut	p/n: 040-781





QUALITY TO THE CORE.

STERLING® WHEELBARROW

Wood Handle / Steel Tray

6c' & 7c'

Fastener Set

(2) 5-1/2"	Carriage Bolts	p/n: 024-356
(2) 3-1/2"	Carriage Bolts	p/n: 024-333
(4) 2-3/4"	Carriage Bolts Hex	p/n: 024-327
(2) 3"	Head Cap Bolts	p/n: 020-330
(2) 1"	Carriage Bolts Flat	p/n: 024-311
(2) 5/16"	Washer	p/n: 041-131
(12) 5/16"	Flange Nuts	p/n: 040-781

