

# ASSEMBLY INSTRUCTIONS

## DINING TABLE

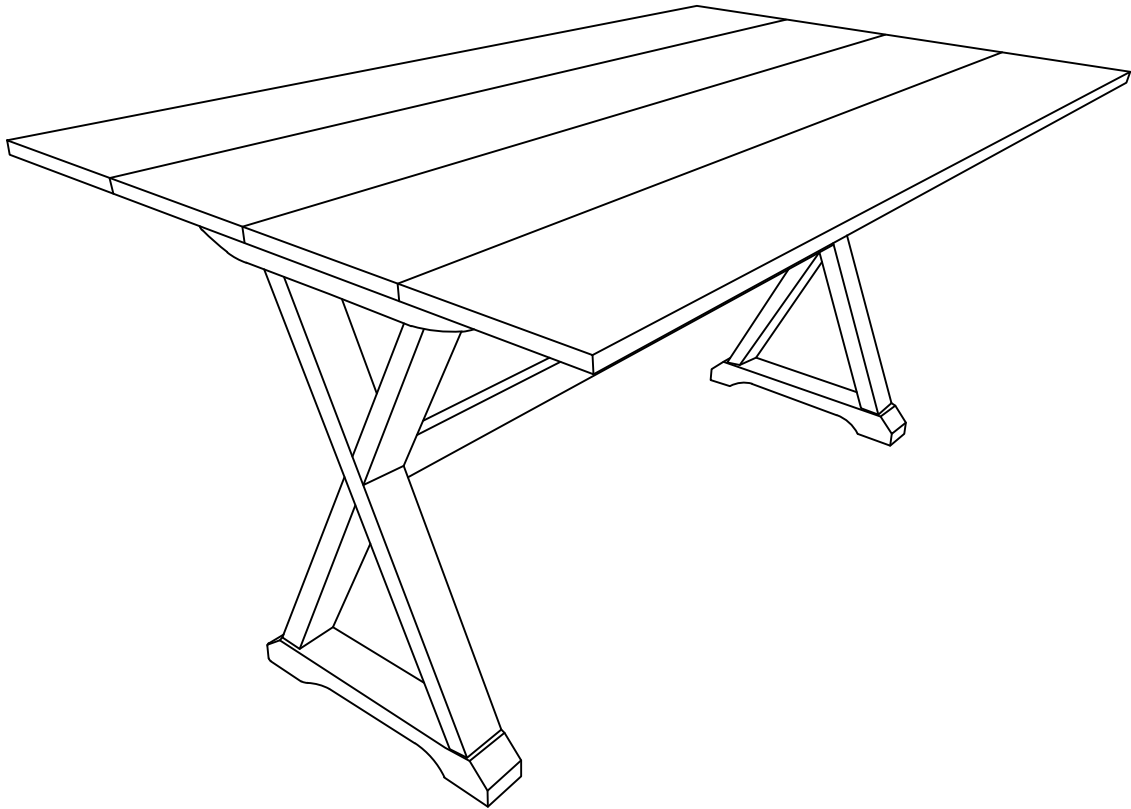

WF309714

### IMPORTANT NOTE:

- PLACE ALL PARTS ON A CLEAN AND SMOOTH SURFACE SUCH AS A RUG OR CARPET TO AVOID THE PARTS FROM BEING SCRATCHED.
- BEFORE YOU BEGIN, KINDLY FOLLOW THE ASSEMBLY INSTRUCTIONS STEP BY STEP.
- DON NOT TIGHTEN ALL SCREWS AND BOLTS UNTIL THE TABLE SET IS FULLY SET-UP.

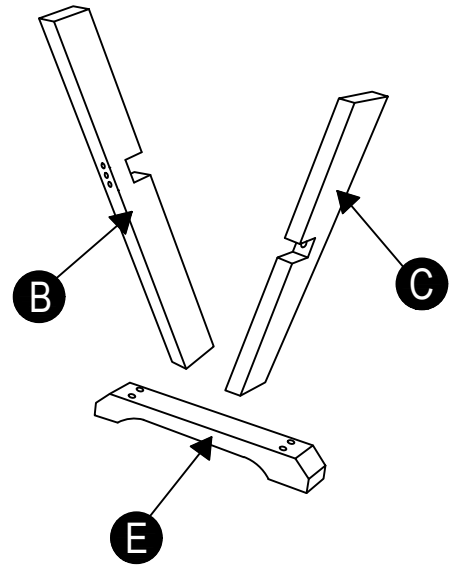
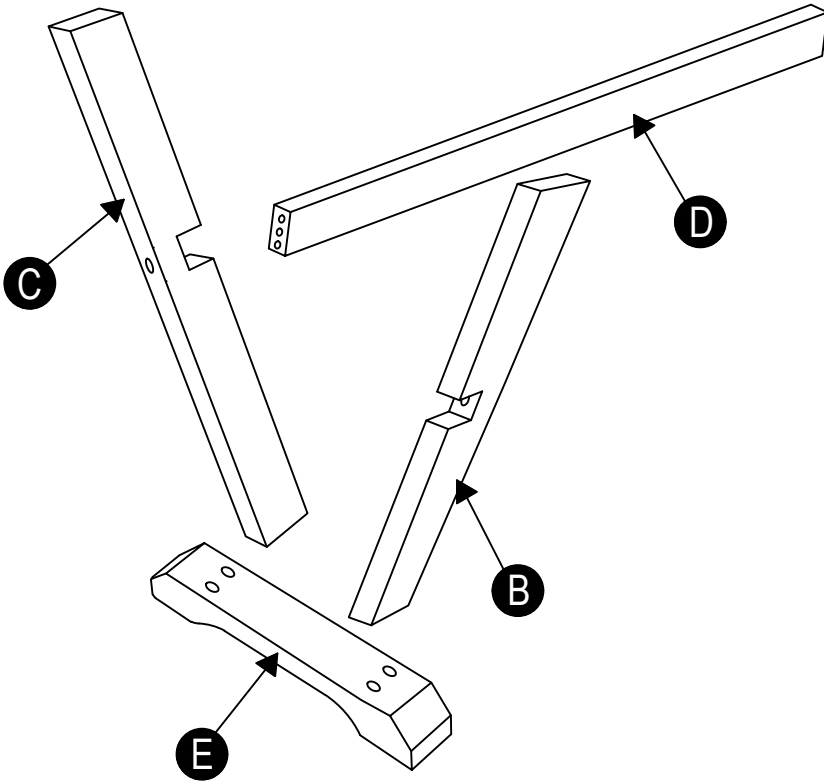
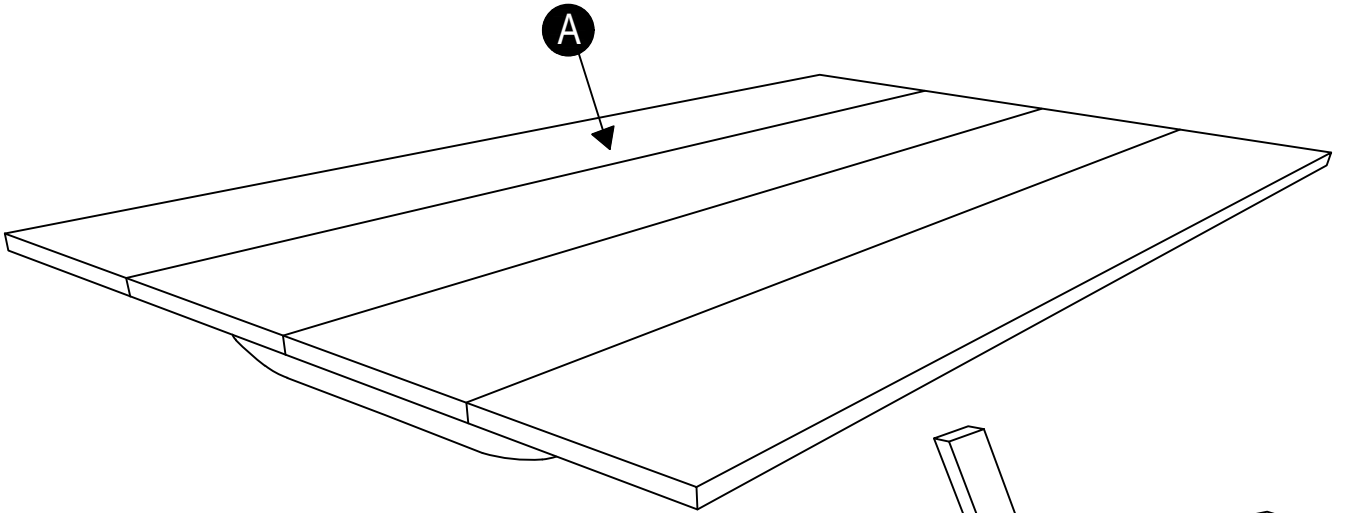

# CARTON CONTENT

WF309714:

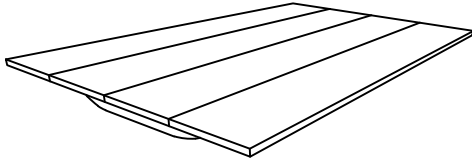

**A** x 1

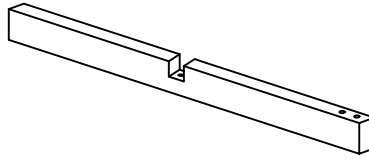

**B** x 2

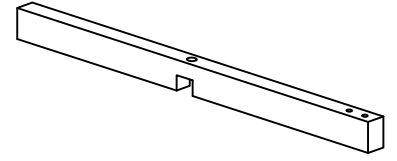

**C** x 2

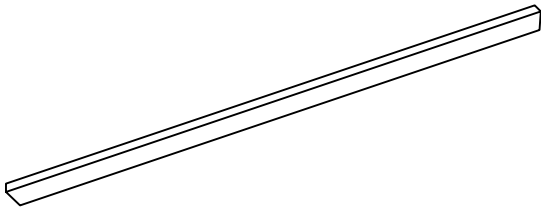

**D** x 1

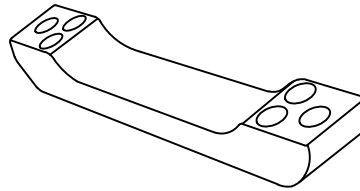

**E** x 2

## TABLE PART LIST FOR ONE

## TABLE HARDWARE LIST FOR ONE

NO	DESCRIPTION	SKETCH	QTY	NO	DESCRIPTION	SKETCH	QTY
A	TABLE TOP WITH APRON		1 PC	1	WOOD DOWEL M8 x 30 MM		4 PCS
B	TABLE LEG 1		2 PCS	2	JCBC SCREW M6 x 40 MM		8 PCS
C	TABLE LEG 2		2 PCS	3	JCBC SCREW M6 x 50 MM		8 PCS
D	STRETCHER		1 PC	4	JCBC SCREW M6 x 70 MM		2 PCS
E	TABLE LEG DOWN		2 PCS	5	SPRING WASHER M6		18 PCS
				6	FLAT WASHER M6 x 13 MM		18 PCS
				7	WOOD BUTTON 14.5MM		10 PCS
				8	ADJUSTABLE M6 x 23MM		4 PCS
				9	ALLEN KEY M4		1 PC

STEP 1

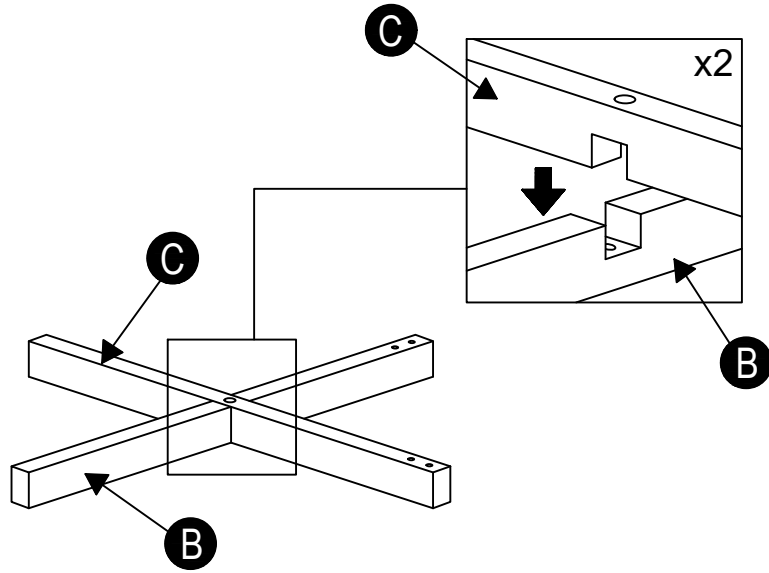

STEP 2

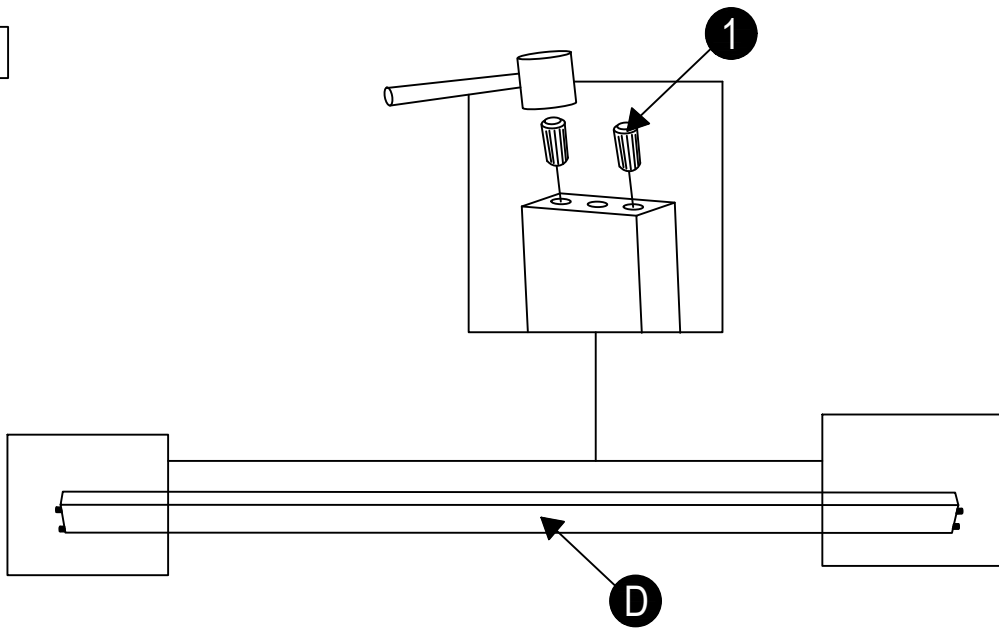

STEP 3

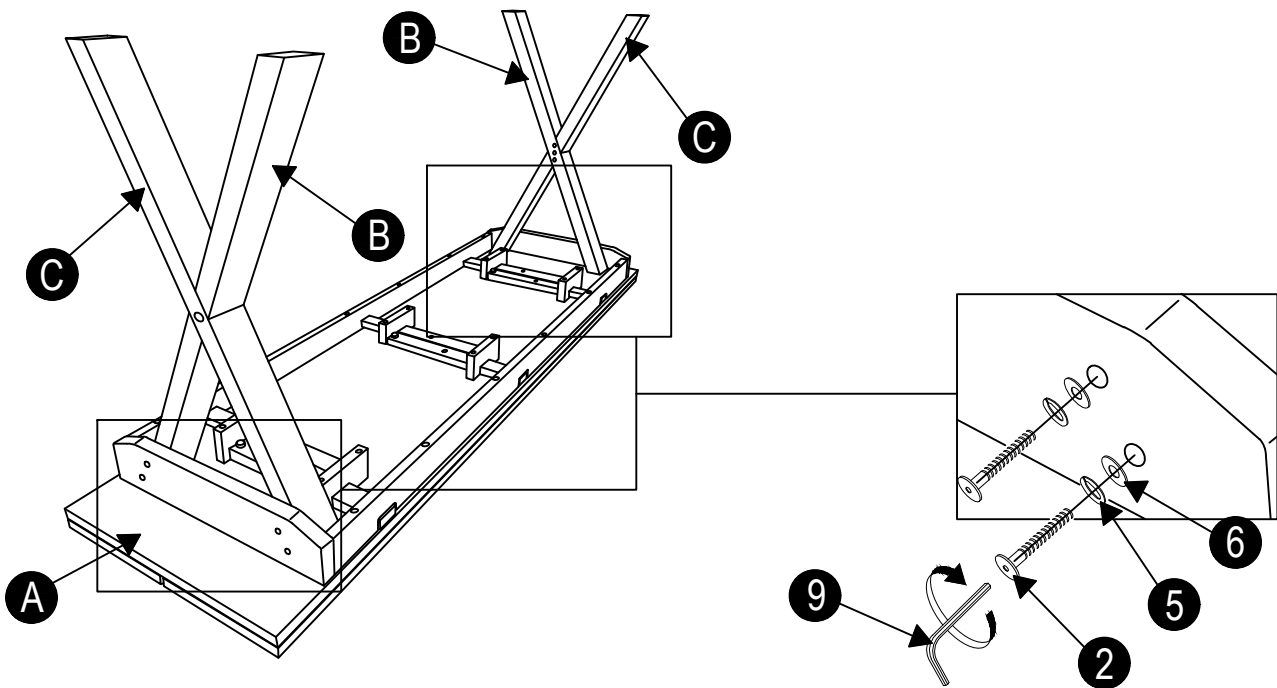

STEP 4

100% 

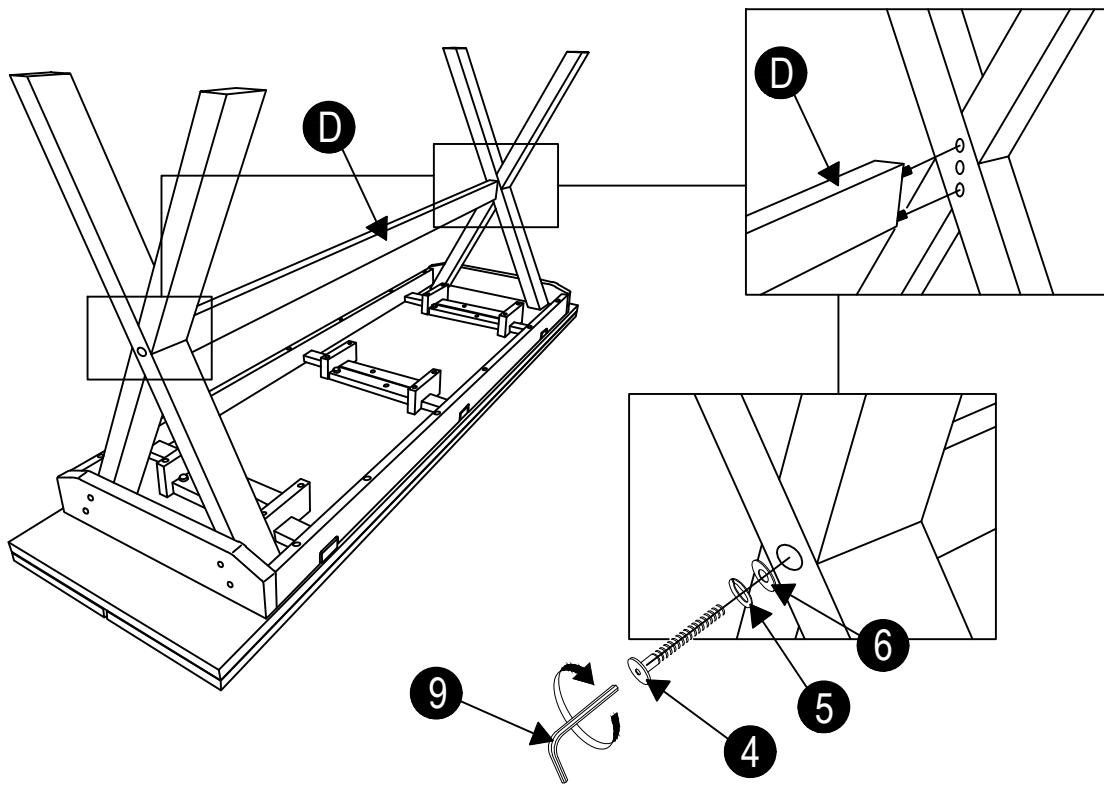

STEP 5

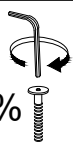
100% 

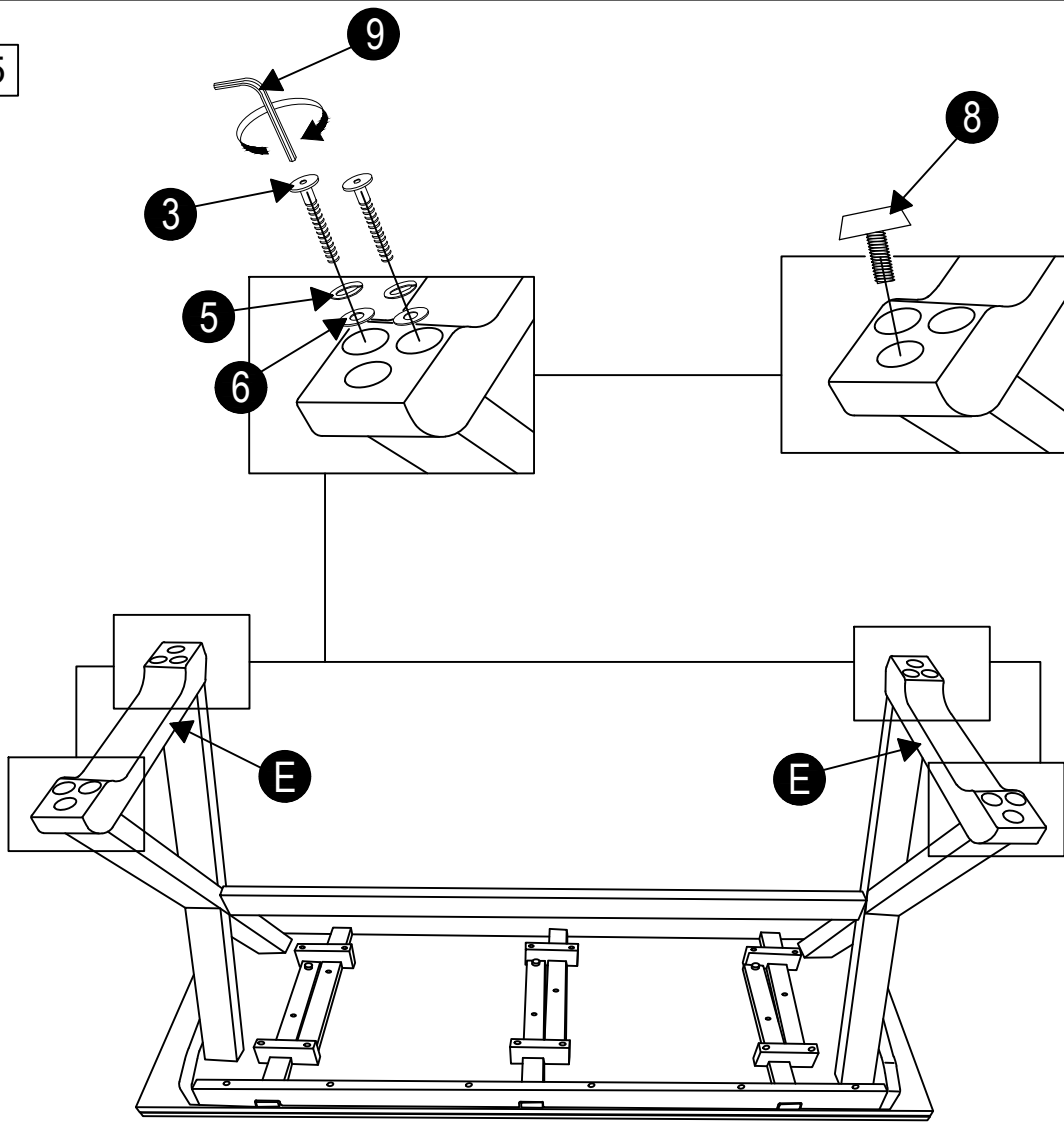

STEP 6

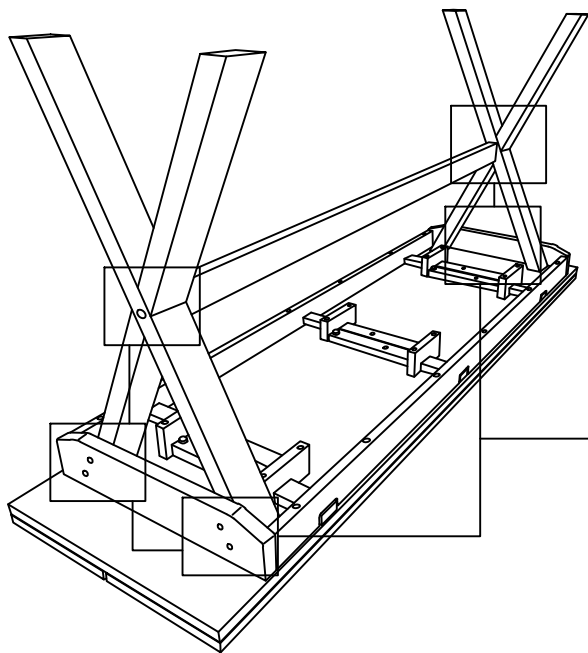

7

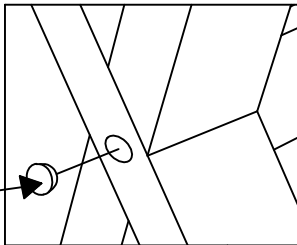

7

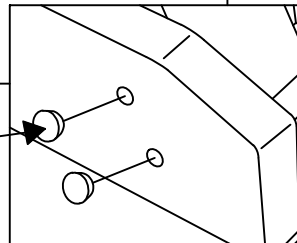

ASSEMBLY COMPLETE !



SMALL MODE

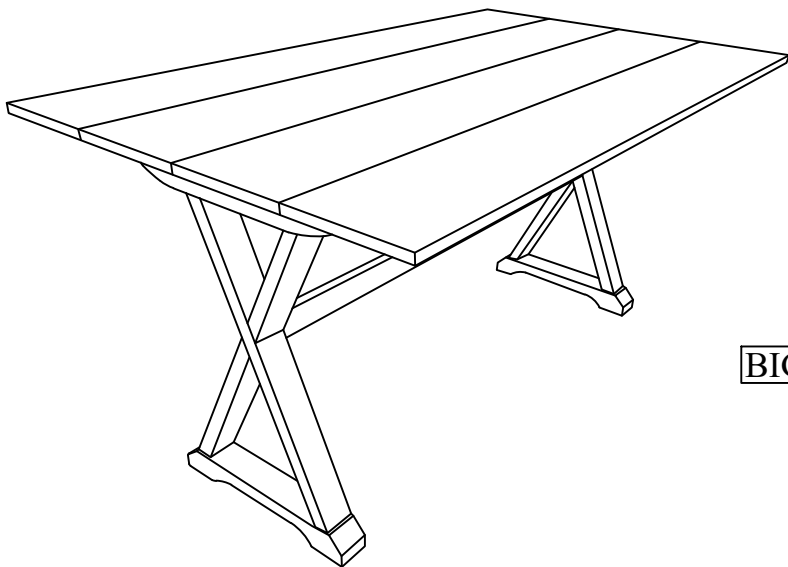
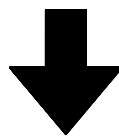
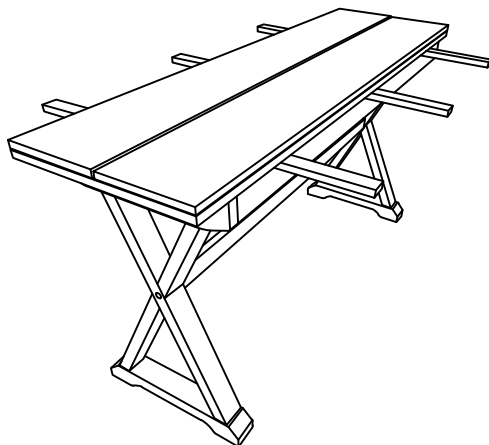
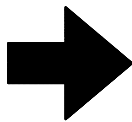

BIG MODE

# ASSEMBLY INSTRUCTIONS

## DINING CHAIR

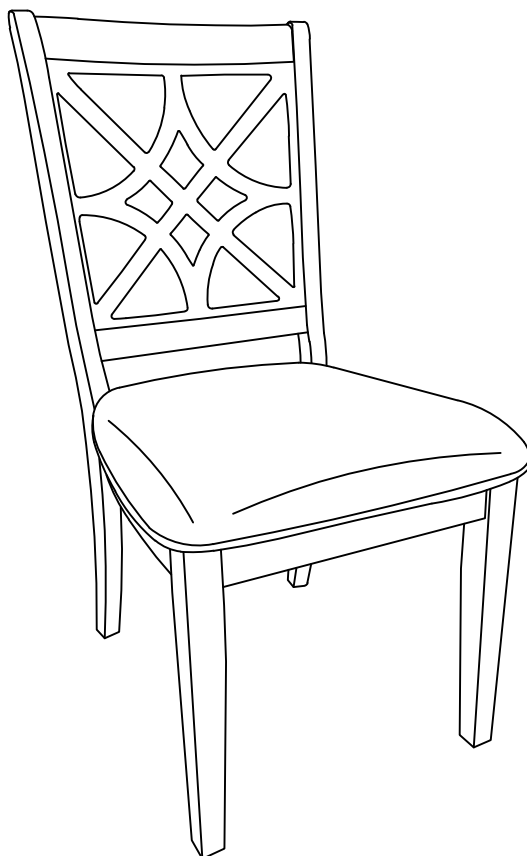

WF309719

### IMPORTANT NOTE:

- PLACE ALL PARTS ON A CLEAN AND SMOOTH SURFACE SUCH AS A RUG OR CARPET TO AVOID THE PARTS FROM BEING SCRATCHED.
- BEFORE YOU BEGIN, KINDLY FOLLOW THE ASSEMBLY INSTRUCTIONS STEP BY STEP.
- DON NOT TIGHTEN ALL SCREWS AND BOLTS UNTIL THE CHAIR SET IS FULLY SET-UP.

# CARTON CONTENT

WF309719:

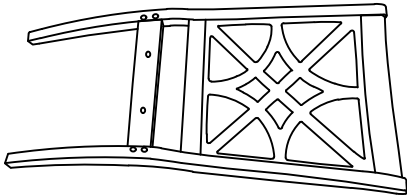

**A** x 4

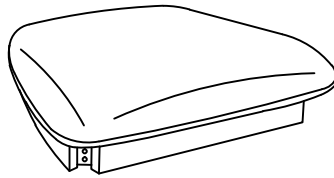









**B** x 4

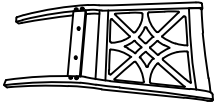

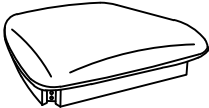
**C** x 8

## CHAIR PART LIST FOR ONE

## CHAIR HARDWARE LIST FOR ONE

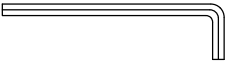
NO	DESCRIPTION	SKETCH	QTY	NO	DESCRIPTION	SKETCH	QTY
A	CHAIR BACK		1 PC	1	JCBC SCREW M6 x 35 MM		2 PCS
B	CUSHION SEAT WITH APRON		1 PC	2	JCBC SCREW M6 x 60 MM		4 PCS
C	CHAIR LEG		2 PCS	3	JCBC SCREW M6 x 80 MM		4 PCS
				4	SPRING WASHER M6		10 PCS
				5	FLAT WASHER M6 x 19 MM		10 PCS
				6	ALLEN KEY M4		1 PC



STEP 1

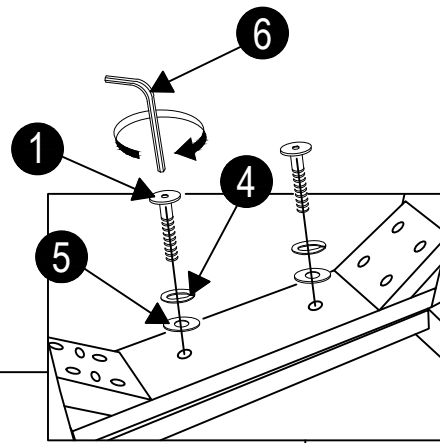
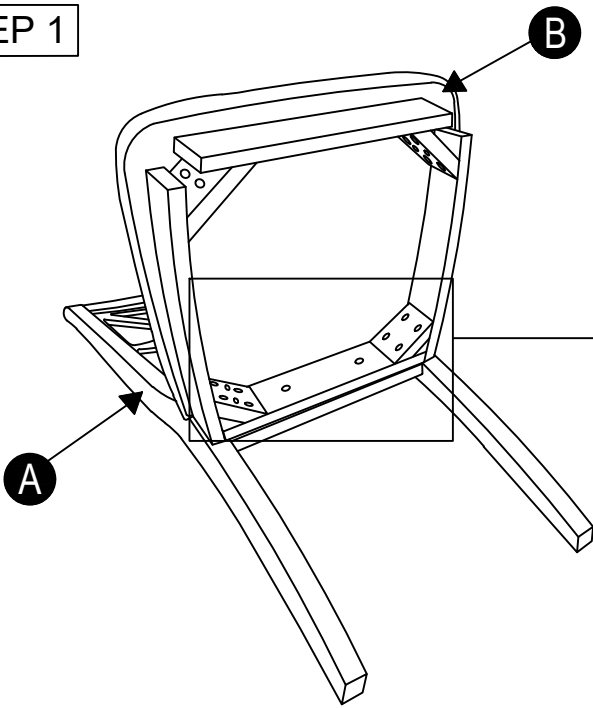

STEP 1.1

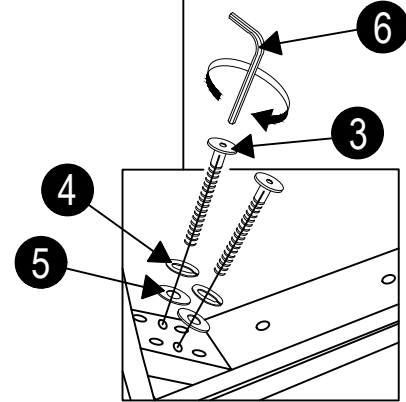

STEP 1.2

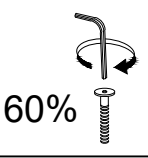

STEP 2

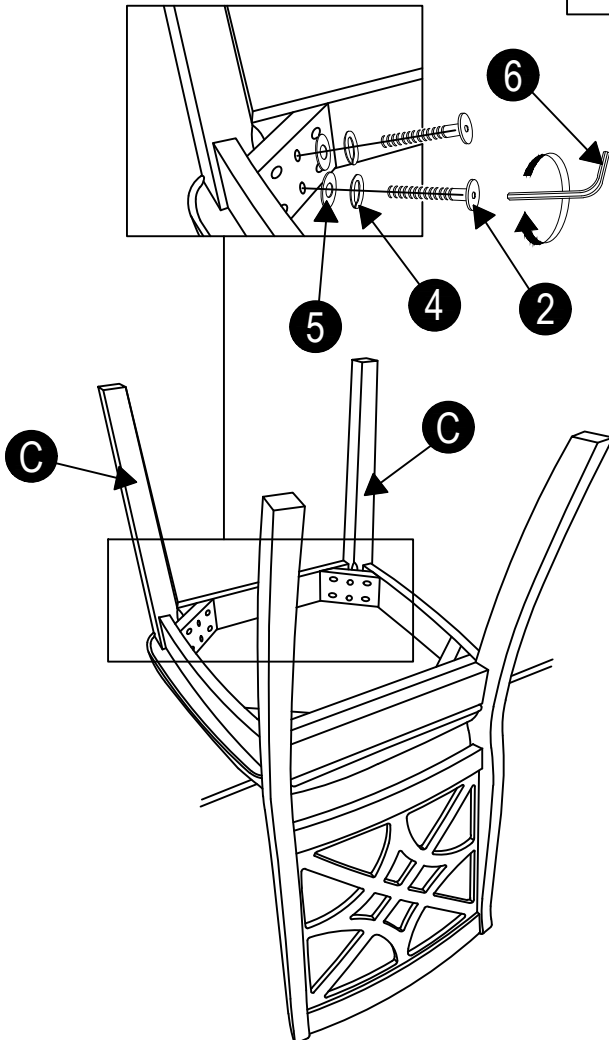
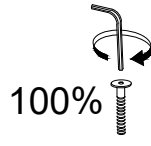

ASSEMBLY COMPLETE !

