

SPECIFICATIONS:

- DIMENSIONS: 5.25" W X 8"L X 2.25" H
- MOTOR: 12VAC/VDC
- ELECTRICAL: ON/OFF SWITCH
- CFM: 114 CFM
- SPEED: 3000 RPM
- CONSTRUCTION: High Density Polyurethane enclosure w/plastic grills
- FILTER: None
- WEIGHT: 1.5 LBS.
- NOISE: 41.6 DBA
- PURIFICATION: Needle Point Bi-Polar Ionization

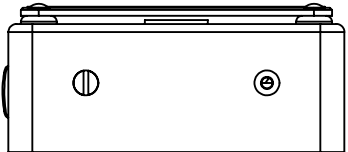
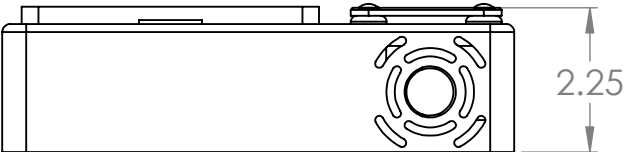
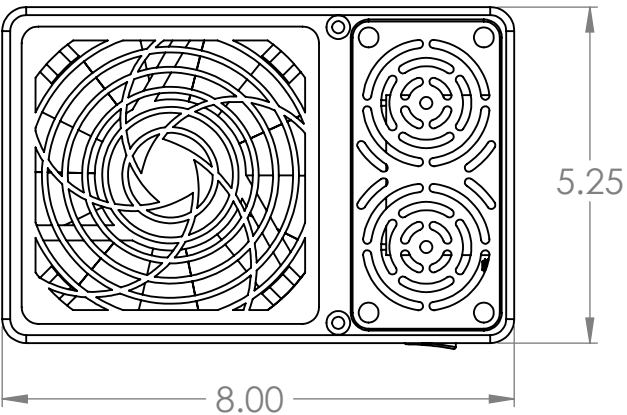

	NAME	DATE	I-Series/Mini-WM12	
DRAWN	MLS	10/20/21		
CHECKED			TITLE:	
INDUSTRIAL MAID 315 S.12 RD. CORTLAND, NE 68331 (877) 624-3247			I Series Mini-WM12	
SIZE	DWG. NO.	REV		
A	Mini-WM12 data sheet			
SCALE: 1:3	WEIGHT:	SHEET 1 OF 1		

PROPRIETARY AND CONFIDENTIAL
 THE INFORMATION CONTAINED IN THIS DRAWING IS THE SOLE PROPERTY OF INDUSTRIAL MAID LLC ANY REPRODUCTION IN PART OR AS A WHOLE WITHOUT THE WRITTEN PERMISSION OF INDUSTRIAL MAID LLC IS PROHIBITED.

