

SPECIFICATIONS:

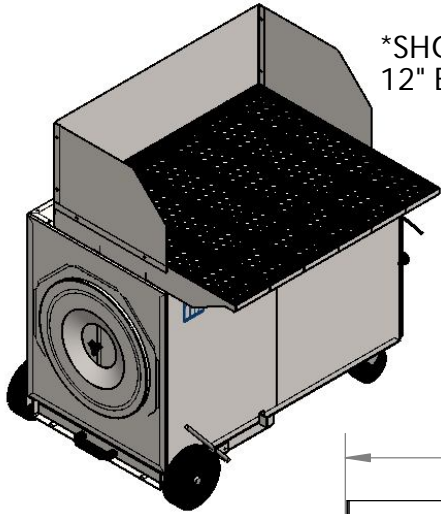

*SHOWN WITH OPT. 12" BACK FENCE

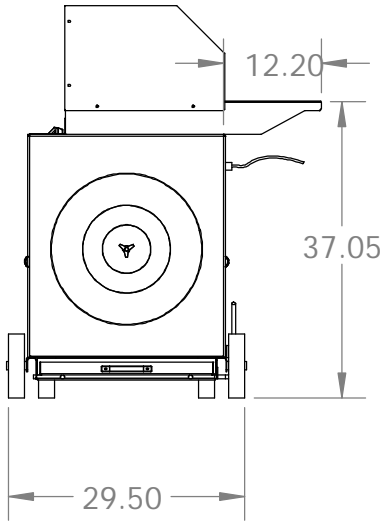
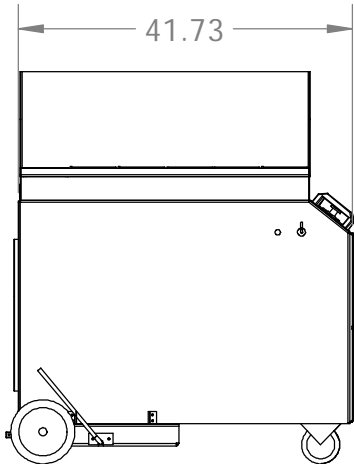
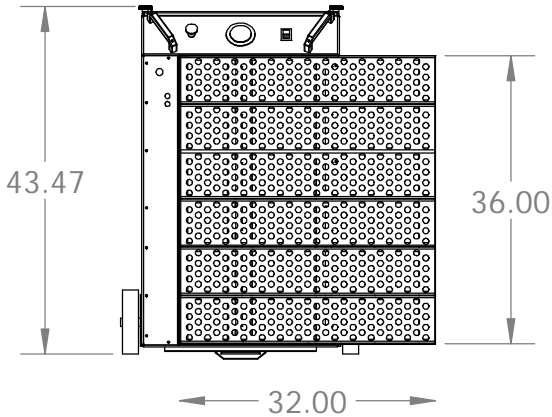

- DIMENSIONS:** 43.5" W X 42"D X 37" H
- MOTOR:** 1.5 HP TEFC
115/208-230/1/60
14.2/7.7-7.1 FLA
- ELECTRICAL:** ON/OFF SWITCH &
25 FT CORD
- CFM:** 1200 CFM @ 5" W.G.
- BLOWER:** DIRECT DRIVE BI
- CONSTRUCTION:** 12 & 14 GA STEEL
GREY POWDERCOAT
5" SWIVEL/LOCK CASTERS
8" EASY ROLL REAR WHEELS
DUST DRAWER W/ CAM
RELEASE LEVER
TOOL-LESS FILTER SERVICE
36"W x 32" D DOWNDRAFT
TABLE, 37" HIGH, 12" TOE SP.
- FILTER:** 200 SF, FR CELL/POLY, 99.5%
* OPT. FR NANO-FIBER
- WEIGHT:** 382 LBS. STD
- NOISE:** 76 DBA
- OPTIONS:** CARBON AFTER FILTER
HEPA AFTERFILTER
3 PHASE MODELS
INTERNAL/PUSH BUTTON
CLEANING
FILTER SERVICE GAUGE
12" SIDE AND BACK SHIELDS
36" HIGH ENCLOSURE
LIGHT KITS

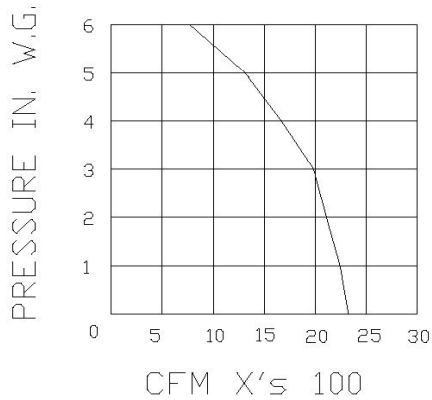

PROPRIETARY AND CONFIDENTIAL

THE INFORMATION CONTAINED IN THIS DRAWING IS THE SOLE PROPERTY OF INDUSTRIAL MAID LLC. ANY REPRODUCTION IN PART OR AS A WHOLE WITHOUT THE WRITTEN PERMISSION OF INDUSTRIAL MAID LLC IS PROHIBITED.



INDUSTRIAL MAID

	NAME	DATE	AZTech PFC12-DD32	
DRAWN	TAA	5/28/14		
CHECKED	JZ	5/28/14		
INDUSTRIAL MAID 315 S.12 RD. CORTLAND, NE 68331 (877) 624-3247			TITLE: 1200 CFM PORTABLE DOWNDRAFT TABLE	
SIZE	DWG. NO.	REV		
A	PFC12-DD32			
SCALE: 1:24		WEIGHT: 382.33	SHEET 1 OF 6	

SPECIFICATIONS:

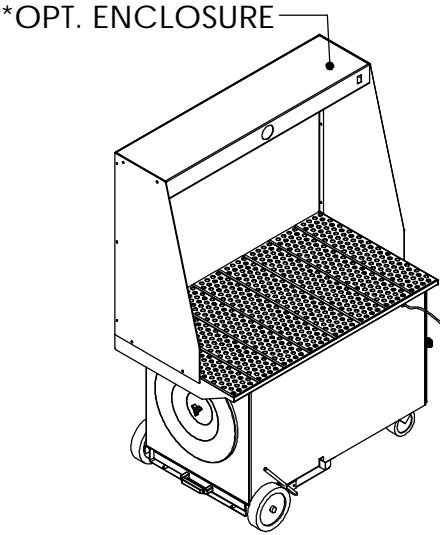
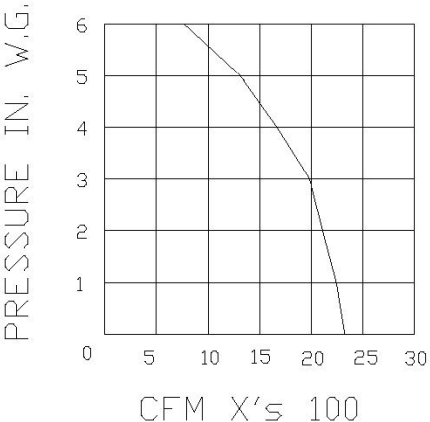

- DIMENSIONS:** 54.5" W X 33"D X 37" H
- MOTOR:** 1.5 HP TEFC
115/208-230/1/60
14.2/7.7-7.1 FLA
- ELECTRICAL:** ON/OFF SWITCH &
25 FT CORD
- CFM:** 1200 CFM @ 5" W.G
- BLOWER:** DIRECT DRIVE BI
- CONSTRUCTION:** 12 & 14 GA STEEL
GREY POWDERCOAT
5" SWIVEL/LOCK CASTERS
8" EASY ROLL REAR WHEELS
DUST DRAWER W/ CAM
RELEASE LEVER
TOOL-LESS FILTER SERVICE
48"W x 28" D DOWNDRAFT
TABLE, 37" HIGH, 12" TOE SP.
- FILTER:** 200 SF, FR CELL/POLY, 99.5%
* OPT. FR NANO-FIBER
- WEIGHT:** 382 LBS. STD
- NOISE:** 76 DBA
- OPTIONS:** CARBON AFTER FILTER
HEPA AFTERFILTER
3 PHASE MODELS
INTERNAL/PUSH BUTTON
CLEANING
FILTER SERVICE GAUGE
12" SIDE AND BACK SHIELDS
36" HIGH ENCLOSURE
LIGHT KITS

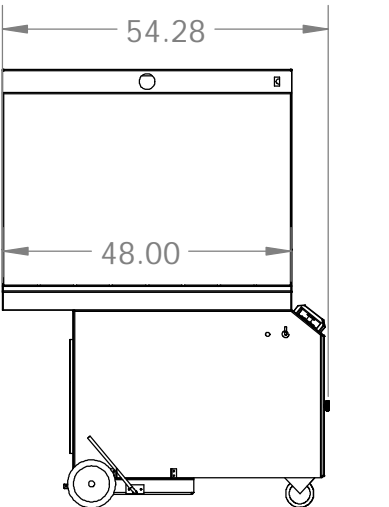
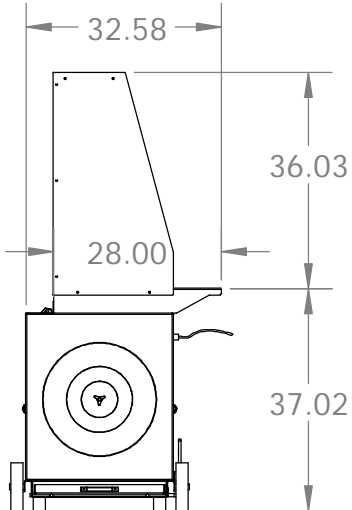

	NAME	DATE	AZTech PFC12-DD48-36E-120S	
DRAWN	TAA	7/28/15	TITLE: PORTABLE DD BENCH 48" x 28" / 36" ENCL.	
CHECKED	JZ	7/29/15		
INDUSTRIAL MAID 315 S.12 RD. CORTLAND, NE 68331 (877) 624-3247			SIZE	REV
 INDUSTRIAL MAID			A	PFC12-DD48
			SCALE: 1:32	WEIGHT: 446.57

PROPRIETARY AND CONFIDENTIAL

THE INFORMATION CONTAINED IN THIS DRAWING IS THE SOLE PROPERTY OF INDUSTRIAL MAID LLC ANY REPRODUCTION IN PART OR AS A WHOLE WITHOUT THE WRITTEN PERMISSION OF INDUSTRIAL MAID LLC IS PROHIBITED.