

PRESSURE IN. W.G.

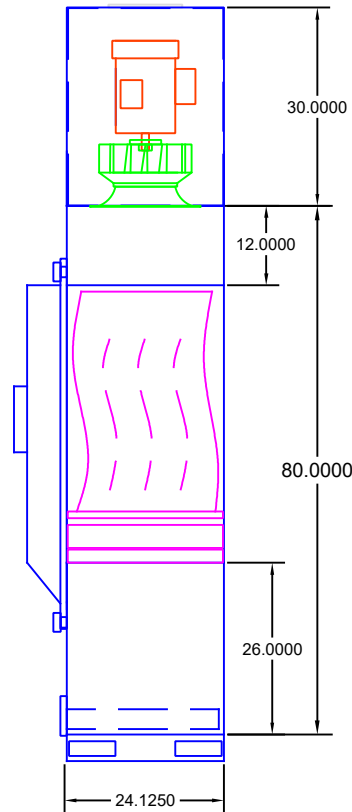

CFM X's 100

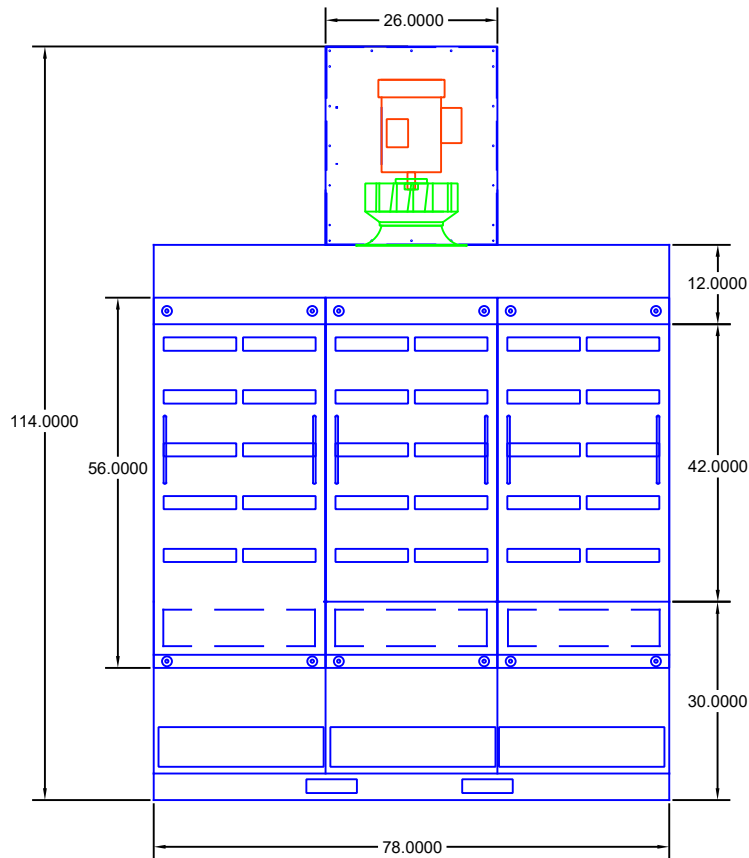
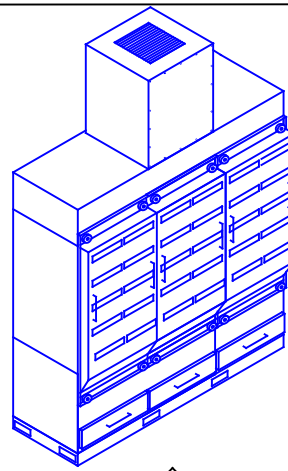

SHEET TITLE **AZTech EB56-MOD-5DD**

DRWG. NO.: **EB56-5DD-060609** DRAWN BY: **TAA**

DATE: **05/15/18** SCALE: **NTS**

SPECIFICATIONS:

- DIMENSIONS: 114"H X 78" W X 28.5" D
- MOTOR: 5 HP 208-230/460/3/60
TEFC MOTOR STD. 13.5-12.4/6.2 FLA
- CFM: 4500 CFM @ 3.0" W.G.
- CONSTRUCTION 7,10,&14 GA POWDER COATED STEEL FRAME.
16 GA. POWDER COATED STEEL PANELS. BAFFLED INLET GRID
GASKETED FRONT FILTER ACCESS
4-WAY ALUMINUM EXHAUST GRILLE
SPARK DROP OUT CHAMBER
*OPTIONAL DUST DRAWERS
- ELECTRICAL WIRED TO JCT. BOX
OPT. MOTOR STARTER
- BLOWER: BACKWARD INCLINED
COMPOSITE WHEEL
- FILTERS: 2" GALV. BAFFLE PREFILTER
4" PLEATED PREFILTER
95% FIBERGLASS BAG FILTER
- OPTIONS: MAGNAHELIC PRESSURE GAUGE
REGAIN
2" ALUMINUM MESH
99.97% HEPA FINAL FILTERS
(4) 26 LB CARBON V-BANKS
2" OR 4" MIST ELIMINATORS
2" POLY PADS
THERMAL SENSOR/ POWER SHUT OFF
- WEIGHT: 1465 LBS. (unit only)
- NIOSE: 83.0 dBA



INDUSTRIAL MAID
INDUSTRIAL MAID LLC
 351 S. 12TH RD.
 CORTLAND, NE 68331
 Ph. (402) 798-7116
 Fax (402) 798-7117
 www.industrial-maid.com

COPYRIGHT: This document and the information contained may not be reproduced or distributed without express written consent of INDUSTRIAL MAID. Unauthorized reproduction, disclosure, or manufacturing use are prohibited by copyright law.