

PRESSURE IN. W.G.

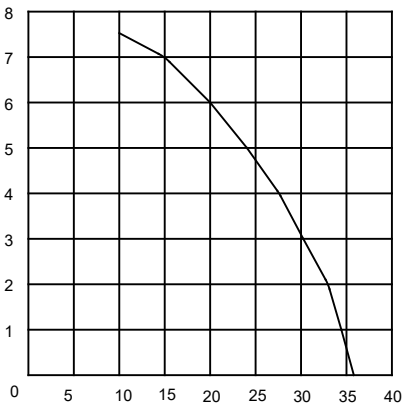

CFM X's 100

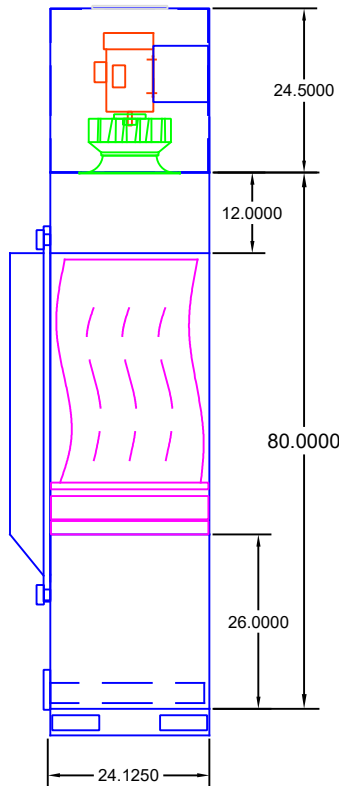
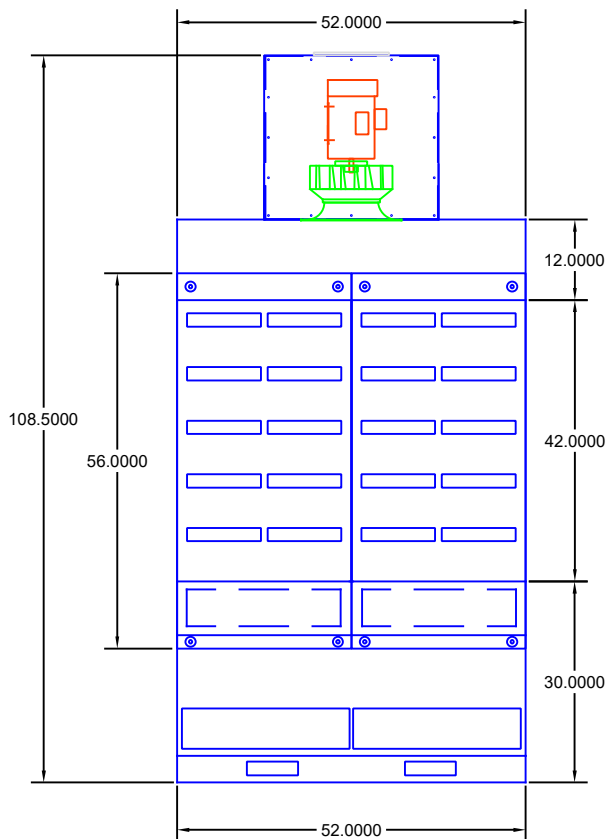
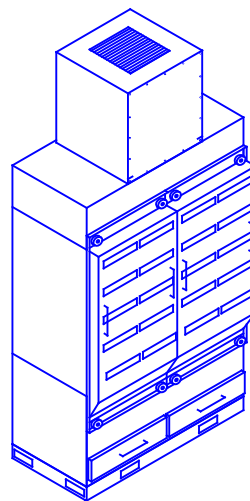

SHEET TITLE: AZTech EB34-MOD-3DD

DRWG. NO.: EB34-3DD-0609 DRAWN BY: TA

DATE: 05/15/18 SCALE: NTS

### SPECIFICATIONS:

DIMENSIONS: 109"H X 48" W X 28.5" D

MOTOR: 3 HP 208-230/460/3/60  
TEFC MOTOR STD. 8.4-7.6/3.8 FLA

CFM: 3500 CFM @ 0.5" W.G.

CONSTRUCTION: 7,10,&14 GA POWDER COATED STEEL FRAME.  
16 GA. POWDER COATED STEEL PANELS. BAFFLED INLET GRID  
GASKETED FRONT FILTER ACCESS  
4-WAY ALUMINUM EXHAUST GRILLE  
SPARK DROP OUT CHAMBER  
\*OPTIONAL DUST DRAWERS

ELECTRICAL: WIRED TO JCT. BOX  
OPT. MOTOR STARTER

BLOWER: BACKWARD INCLINED  
COMPOSITE WHEEL

FILTERS: 2" GALV. BAFFLE PREFILTER  
4" PLEATED PREFILTER  
95% FIBERGLASS BAG FILTER

OPTIONS: MAGNAHELIC PRESSURE GAUGE  
REGAIN  
2" ALUMINUM MESH  
99.97% HEPA FINAL FILTERS  
(4) 26 LB CARBON V-BANKS  
2" OR 4" MIST ELIMINATORS  
2" POLY PADS  
THERMAL SENSOR/ POWER SHUT OFF

WEIGHT: 1190 LBS.

NOISE: 80.2 dBA



**INDUSTRIAL MAID**  
**INDUSTRIAL MAID LLC**  
 351 S. 12TH RD.  
 CORTLAND, NE 68331  
 Ph. (402) 798-7116  
 Fax (402) 798-7117  
[www.industrial-maid.com](http://www.industrial-maid.com)

DIST. BY:

**COPYRIGHT:** This document and the information contained may not be reproduced or distributed without express written consent of INDUSTRIAL MAID. Unauthorized reproduction, disclosure, or manufacturing use are prohibited by copyright law.