

SHEET TITLE : **AZTech FW60-2**

DRWG. NO.: **FW62-081307** DRAWN BY: **TAA**

DATE: **08/13/07** SCALE: **NTS**

**SPECIFICATIONS:**

**DIMENSIONS:** 53"H X 130" W X 26.5" D

**MOTOR:** 5 HP 208-230/460/3/60  
TEFC MOTOR, 14.0-12.6/6.3 FLA

**CFM:** 6500 CFM @ 1.0" w.g.

**CONSTRUCTION** 14 & 16 GA POWDER COATED STEEL FRAME,  
3/16 POLYETHYLENE PANELS. FULL CARBON STEEL CONSTRUCTION AVAILABLE.  
4-WAY ALUMINUM EXHAUST GRILLE

**ELECTRICAL** WIRED TO JCT. BOX  
OPT. MOTOR STARTER

**BLOWER:** 12 X 12 FORWARD CURVED BLOWER

**FILTERS:** 2" ALUMINUM BAFFLE PREFILTER  
4" PLEATED PREFILTER  
95% FIBERGLASS BAG FILTER

**OPTIONS:** HEPA AFTER FILTER  
SILENCER  
MAGNAHELIC PRESSURE GAUGE  
2" ALUMINUM MESH

**WEIGHT:** 628 lbs.

**NOISE:** 75.4 dBA

**COPYRIGHT:** This document and the information contained may not be reproduced or distributed without express written consent of INDUSTRIAL MAID. Unauthorized reproduction, disclosure, or manufacturing use are prohibited by copyright law.



**INDUSTRIAL MAID**  
INDUSTRIAL MAID LLC  
351 S. 12TH RD.  
CORTLAND, NE 68331  
Ph. (402) 798-7116  
Fax (402) 798-7117  
[www.industrial-maid.com](http://www.industrial-maid.com)

STATIC PRESSURE, W.G.

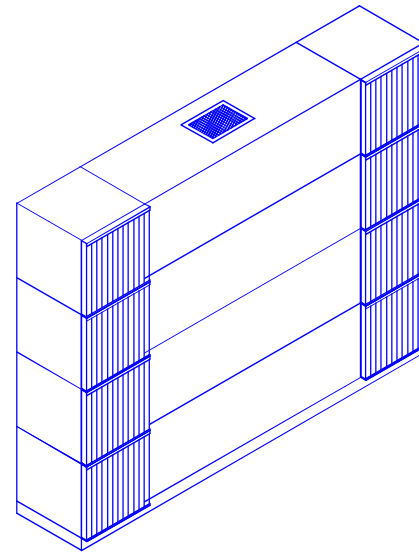
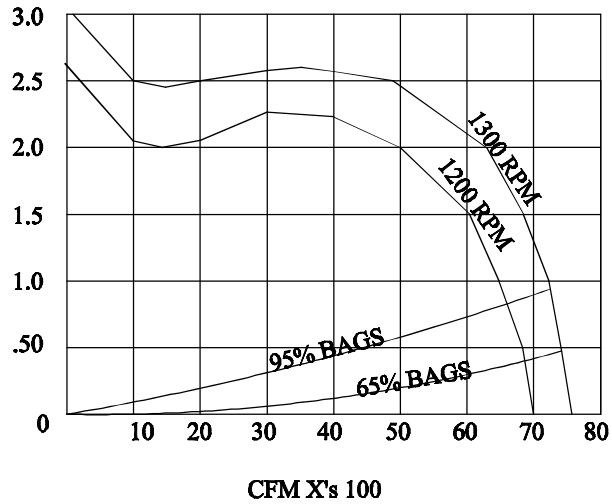

SHEET TITLE: **AZTech FW60-4**

DRWG. NO.: **FW64-081307** DRAWN BY: **TAA**

DATE: **08/13/07** SCALE: **NTS**

### SPECIFICATIONS:

**DIMENSIONS:** 102"H X 130" W X 26.5" D

**MOTOR:** 5 HP 208-230/460/3/60  
TEFC MOTOR, 14.0-12.6/6.3 FLA

**CFM:** 7500 CFM

**CONSTRUCTION** 14 & 16 GA POWDER COATED STEEL FRAME.  
3/16 POLYETHYLENE PANELS. FULL CARBON STEEL CONSTRUCTION AVAILABLE.  
4-WAY ALUMINUM EXHAUST GRILLE

**ELECTRICAL** WIRED TO JCT. BOX  
OPT. MOTOR STARTER

**BLOWER:** 12 X 12 FORWARD CURVED BLOWER  
OPTIONAL BI TOP MOUNTED FAN

**FILTERS:** 2" ALUMINUM BAFFLE PREFILTER  
2" ALUMINUM MESH  
4" PLEATED PREFILTER  
95% FIBERGLASS BAG FILTER

**OPTIONS:** HEPA AFTER FILTER  
SILENCER  
MAGNAHELIC PRESSURE GAUGE

**WEIGHT:** 993 LBS.

**NOISE:** 75.4 dBA

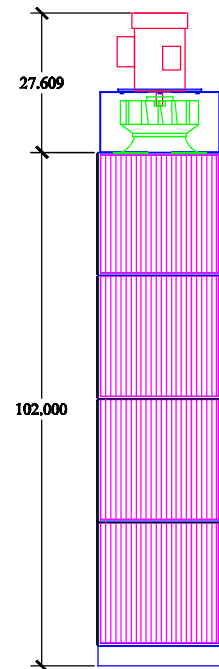
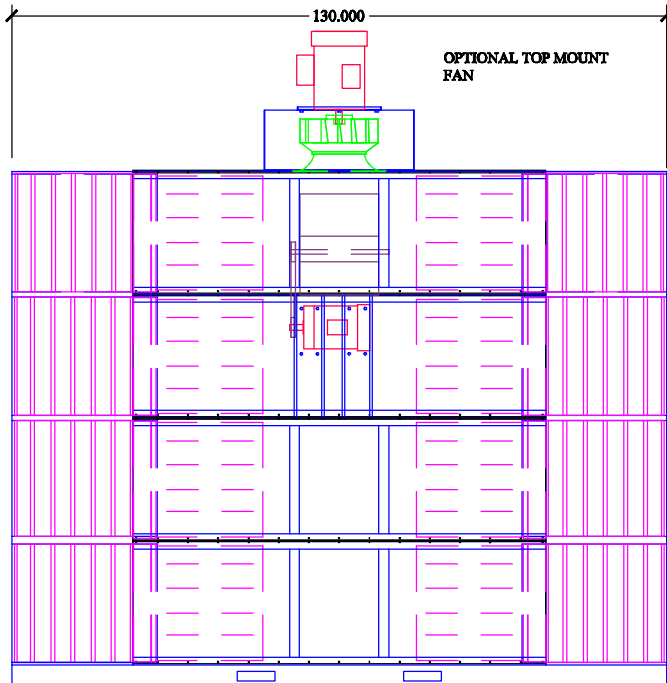

**COPYRIGHT:** This document and the information contained may not be reproduced or distributed without express written consent of INDUSTRIAL MAID. Unauthorized reproduction, disclosure, or manufacturing use are prohibited by copyright law.



**INDUSTRIAL MAID**  
INDUSTRIAL MAID LLC  
351 S. 12TH RD.  
CORTLAND, NE 68331  
Ph. (402) 798-7116  
Fax (402) 798-7117  
[www.industrial-maid.com](http://www.industrial-maid.com)

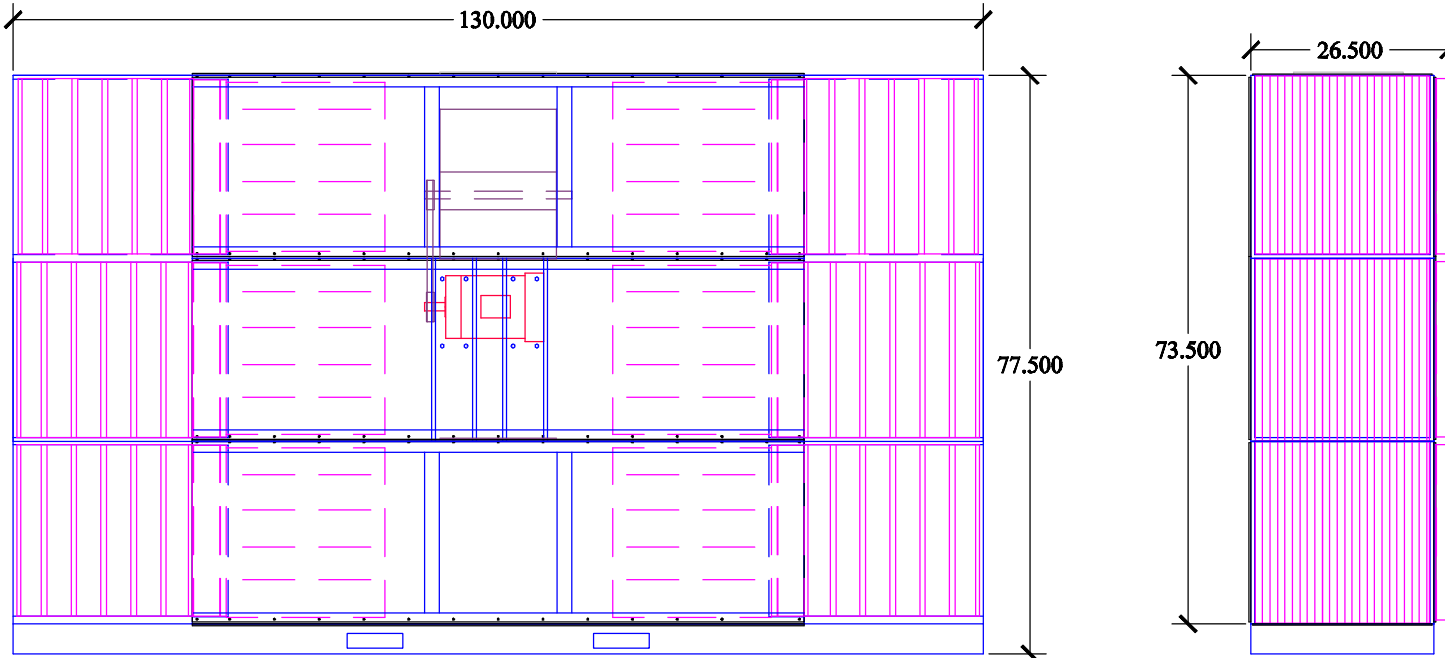
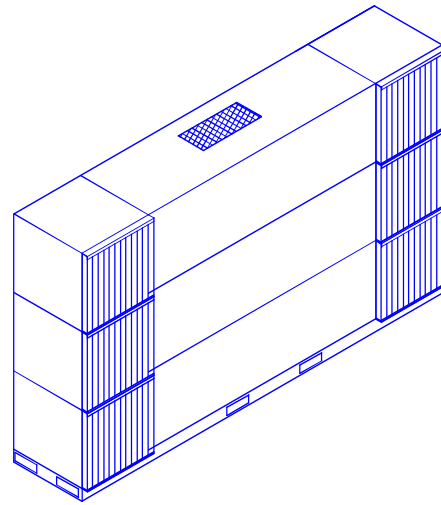
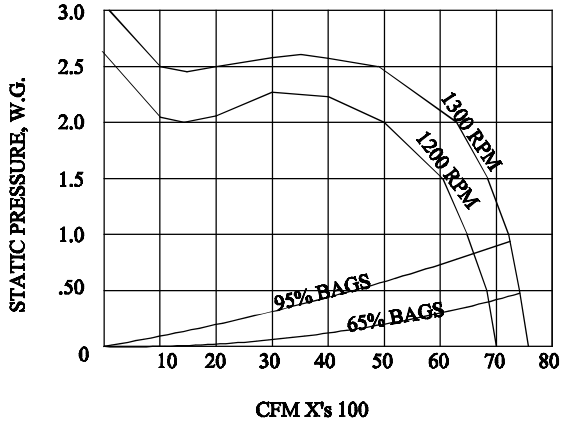

SHEET TITLE : **AZTech FW60-3**  
 DRWG. NO.: **FW63-081307** DRAWN BY: **TAA**  
 DATE: **08/13/07** SCALE: **NTS**

**SPECIFICATIONS:**

- DIMENSIONS:** 77.5"H X 130" W X 26.5" D
- MOTOR:** 5 HP 208-230/460/3/60 TEFC MOTOR, 14.0-12.6/6.3 FLA
- CFM:** 6500 CFM @ 1.0" w.g.
- CONSTRUCTION:** 14 & 16 GA POWDER COATED STEEL FRAME.  
3/16 POLYETHYLENE PANELS. FULL CARBON STEEL CONSTRUCTION AVAILABLE.  
4-WAY ALUMINUM EXHAUST GRILLE
- ELECTRICAL:** WIRED TO JCT. BOX  
OPT. MOTOR STARTER
- BLOWER:** 12 X 12 FORWARD CURVED BLOWER
- FILTERS:** 2" ALUMINUM BAFFLE PREFILTER  
4" PLEATED PREFILTER  
95% FIBERGLASS BAG FILTER
- OPTIONS:** HEPA AFTER FILTER  
SILENCER  
MAGNAHELIC PRESSURE GAUGE  
2" ALUMINUM MESH
- WEIGHT:** 795 lbs.
- NOISE:** 72.0 dBA

**COPYRIGHT:** This document and the information contained may not be reproduced or distributed without express written consent of INDUSTRIAL MAID. Unauthorized reproduction, disclosure, or manufacturing use are prohibited by copyright law.



**INDUSTRIAL MAID**  
 INDUSTRIAL MAID LLC  
 351 S. 12TH RD.  
 CORTLAND, NE 68331  
 Ph. (402) 798-7116  
 Fax (402) 798-7117  
 www.industrial-maid.com