

**SPECIFICATIONS:**

- DIMENSIONS: 11" W X 6"D X 8.75" H
- MOTOR: 115V / 1ph / 60Hz
- ELECTRICAL: ON/OFF SWITCH & 6 FT CORD
- CFM: 232 CFM
- SPEED: 2800 RPM
- CONSTRUCTION: Recycled High Density Polyethylene Enclosure  
anti vibration rubber feet  
plastic grills & handle
- FILTER: None
- WEIGHT: 5 LBS.
- NOISE: 41.6 DBA
- PURIFICATION: Needle Point Bipolar Ionization

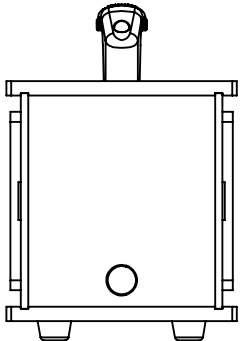
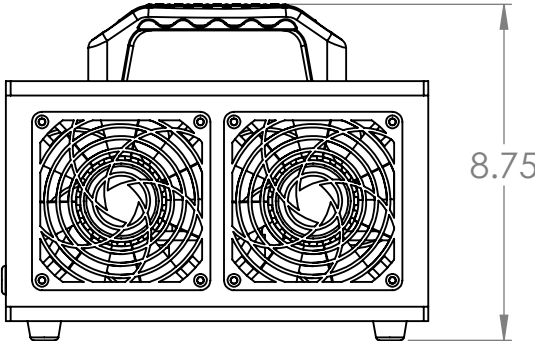
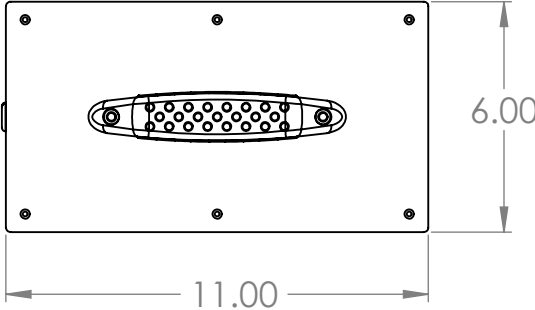

	NAME	DATE	I-Series/Mini-PT15		
DRAWN	MLS	10/20/21			
CHECKED			TITLE:		
INDUSTRIAL MAID 315 S.12 RD. CORTLAND, NE 68331 (877) 624-3247			<h1 style="text-align: center;">I Series Mini-PT15</h1>		
SIZE	DWG. NO.	REV			
<b>A</b>	Mini-PT15 data sheet		SCALE: 1:5	WEIGHT:	SHEET 1 OF 1

**PROPRIETARY AND CONFIDENTIAL**

THE INFORMATION CONTAINED IN THIS DRAWING IS THE SOLE PROPERTY OF INDUSTRIAL MAID LLC ANY REPRODUCTION IN PART OR AS A WHOLE WITHOUT THE WRITTEN PERMISSION OF INDUSTRIAL MAID LLC IS PROHIBITED.

